

# NON-PROGRAMMABLE | ON DELAY, INTERVAL, TRUE OFF DELAY & FLASHER

## TR-5 SERIES



- ◆ Onboard & remote adjustable or fixed time delays from 0.05 seconds to 2 hours
- ◆ Uses industry-standard 8 pin octal sockets
- ◆ 10A DPDT output contacts



FUNCTION ■	INPUT VOLTAGE 50/60Hz.	PRODUCT NUMBER **	WIRING/ SOCKETS ▲
<b>ON DELAY</b> <b>A</b>	120V AC/DC 12V DC 24V AC/DC 240V AC	TR-50222-** TR-50226-** TR-50228-** TR-50221-**	8 PIN OCTAL <b>70169-D</b>  <b>DIAGRAM 1</b>
<b>INTERVAL ON</b> <b>B</b>	120V AC/DC 12V DC 24V AC/DC 240V AC	TR-50522-** TR-50526-** TR-50528-** TR-50521-**	
<b>TRUE OFF DELAY</b> <b>R</b>	120V AC/DC 12V DC 24V AC/DC 240V AC	TR-50622-** TR-50626-** TR-50628-** TR-50621-**	
<b>FLASHER</b> (OFF 1st) <b>E</b>	120V AC/DC 12V DC 24V AC/DC 240V AC	TR-50822-** TR-50826-** TR-50828-** TR-50821-**	

■ See "Definitions of Timing Functions".

\*\* Complete Product Number using two-digit Code from Table below.

▲ Note: If these products are ordered with the Remote Adjustable Time Delay modification (suffix -Rx), they will require an 11 pin octal socket—see [www.macromatic.com/remote](http://www.macromatic.com/remote) for information. Remote Adjustable Time Delay not available on TR-506 products.

## TIME DELAYS

TR-5 Series Products have three time delay options:

- **Onboard Adjustable Time Delay**--complete Product Number by adding two-digit Code from Table at right, i.e., TR-50222-05 is an On Delay with a time delay range of 0.1-10 seconds.
- **Onboard Fixed Time Delay**--replace two-digit Code with suffix "F" followed by delay [0.1 ... 100] followed by (S) seconds, (M) minutes or (H) hours, i.e., TR-50222-F5S is an On Delay with a time delay fixed at 5 seconds.
- **Remote Adjustable Time Delay**--Selected TR-5 Series products can be built with two terminals for remote adjustable or fixed time delays. See [www.macromatic.com/remote](http://www.macromatic.com/remote) for information.

\*\* TIMING RANGE TABLE

Time Delay Range	Code
0.05 - 5 Sec.	04
0.1 - 10 Sec.	05
0.3 - 30 Sec.	07✘
0.6 - 60 Sec.	08
1.2 - 120 Sec.	09
1.8 - 180 Sec.	10
3 - 300 Sec.	12
0.1 - 10 Min.	22
0.3 - 30 Min.	15
0.6 - 60 Min.	16✘
1.2 - 120 Min.	17✘

✘ Not offered on TR-506

Sockets & Accessories available

Build your Time Delay Relays with the [Online Product Builder](#)



Better. By Design.

**800.238.7474**

[WWW.MACROMATIC.COM](http://WWW.MACROMATIC.COM)

[SALES@MACROMATIC.COM](mailto:SALES@MACROMATIC.COM)

# NON-PROGRAMMABLE | OFF DELAY, SINGLE SHOT, WATCHDOG & SINGLE SHOT FALLING EDGE

## TR-5 SERIES

FUNCTION ■ ▲	INPUT VOLTAGE 50/60Hz.	PRODUCT NUMBER **	WIRING/SOCKETS ▲
<b>OFF DELAY</b> Control Switch Trigger <b>C</b>	120V AC/DC 12V DC 24V AC/DC 240V AC	TR-51622-** TR-51626-** TR-51628-** TR-51621-**	<p><b>DIAGRAM 2</b></p>
<b>SINGLE SHOT</b> Control Switch Trigger <b>D</b>	120V AC/DC 12V DC 24V AC/DC 240V AC	TR-51522-** TR-51526-** TR-51528-** TR-51521-**	
<b>WATCHDOG</b> Control Switch Trigger (Retriggerable Single Shot) <b>J</b>	120V AC/DC 12V DC 24V AC/DC 240V AC	TR-51322-** TR-51326-** TR-51328-** TR-51321-**	
<b>SINGLE SHOT FALLING EDGE</b> Control Switch Trigger <b>H</b>	120V AC/DC 12V DC 24V AC/DC 240V AC	TR-52222-** TR-52226-** TR-52228-** TR-52221-**	
<b>OFF DELAY</b> Power Trigger <b>C</b>	120V AC/DC 12V DC 24V AC/DC 240V AC	TR-51922-** TR-51926-** TR-51928-** TR-51921-**	<p><b>DIAGRAM 4</b></p>
<b>SINGLE SHOT</b> Power Trigger <b>D</b>	120V AC/DC 12V DC 24V AC/DC 240V AC	TR-51722-** TR-51726-** TR-51728-** TR-51721-**	
<b>WATCHDOG</b> Power Trigger (Retriggerable Single Shot) <b>J</b>	120V AC/DC 12V DC 24V AC/DC 240V AC	TR-51822-** TR-51826-** TR-51828-** TR-51821-**	



- ◆ Onboard & remote adjustable or fixed time delays from 0.05 seconds to 2 hours
- ◆ Uses industry-standard 11 pin octal sockets
- ◆ 10A DPDT output contacts



■ See "Definitions of Timing Functions".

\*\* Complete Product Number using two-digit Code from Table below.

▲ 8 Pin SPDT versions of these functions (except Single Shot Falling Edge) are available.

## TIME DELAYS

TR-5 Series Products have three time delay options:

- **Onboard Adjustable Time Delay**--complete Product Number by adding two-digit Code from Table at right, i.e., TR-51622-05 is an Off Delay with a time delay range of 0.1-10 seconds.
- **Onboard Fixed Time Delay**--replace two-digit Code with suffix "F" followed by delay [0.1 ... 100] followed by (S) seconds, (M) minutes or (H) hours, i.e., TR-51622-F5S is an Off Delay with a time delay fixed at 5 seconds.
- **Remote Time Delay**--Selected TR-5 Series products can be built with two terminals for remote adjustable or fixed time delays. See [www.macromatic.com/remote](http://www.macromatic.com/remote) for information.

** TIMING RANGE TABLE	
Time Delay Range	Code
0.05 - 5 Sec.	04
0.1 - 10 Sec.	05
0.3 - 30 Sec.	07
0.6 - 60 Sec.	08
1.2 - 120 Sec.	09
1.8 - 180 Sec.	10
3 - 300 Sec.	12
0.1 - 10 Min.	22
0.3 - 30 Min.	15
0.6 - 60 Min.	16
1.2 - 120 Min.	17

Sockets & Accessories available

Build your Time Delay Relays with the [Online Product Builder](#)



Better. By Design.

**800.238.7474**

[WWW.MACROMATIC.COM](http://WWW.MACROMATIC.COM)

[SALES@MACROMATIC.COM](mailto:SALES@MACROMATIC.COM)

# NON-PROGRAMMABLE | REPEAT CYCLE, ON/OFF DELAY, & DELAYED INTERVAL

## TR-5 SERIES



- ◆ Onboard & remote adjustable or fixed time delays from 0.05 seconds to 2 hours
- ◆ Independently adjustable ON & OFF times
- ◆ Uses industry-standard 8 or 11 pin octal sockets
- ◆ 10A DPDT output contacts



FUNCTION ■	INPUT VOLTAGE 50/60Hz.	PRODUCT NUMBER **	WIRING/SOCKET
<b>REPEAT CYCLE*</b> (OFF Time First Followed By ON Time and Repeating) <b>L</b>	120V AC/DC 12V DC 24V AC/DC 240V AC	TR-53122-** TR-53126-** TR-53128-** TR-53121-**	8 PIN OCTAL <b>70169-D</b>  <b>DIAGRAM 1</b>
<b>ON/TRUE OFF DELAY</b> <b>T</b>	120V AC/DC 12V DC 24V AC/DC 240V AC	TR-54622-** TR-54626-** TR-54628-** TR-54621-**	
<b>REPEAT CYCLE*</b> (ON Time First Followed By OFF Time and Repeating) <b>M</b>	120V AC/DC 12V DC 24V AC/DC 240V AC	TR-55122-** TR-55126-** TR-55128-** TR-55121-**	
<b>DELAYED INTERVAL*</b> (OFF Time Followed by ON Time Followed by OFF State Until Reset) <b>N</b>	120V AC/DC 12V DC 24V AC/DC 240V AC	TR-56122-** TR-56126-** TR-56128-** TR-56121-**	
<b>ON/OFF DELAY*</b> Control Switch Trigger <b>G</b>	120V AC/DC 12V DC 24V AC/DC 240V AC	TR-54122-** TR-54126-** TR-54128-** TR-54121-**	 <b>DIAGRAM 2</b>
<b>DELAYED INTERVAL*</b> Control Switch Trigger (OFF Time Followed by ON Time Followed by OFF State Until Reset) <b>P</b>	120V AC/DC 12V DC 24V AC/DC 240V AC	TR-56522-** TR-56526-** TR-56528-** TR-56521-**	

■ See "Definitions of Timing Functions".

\* ON & OFF Time Ranges for these functions are the same. See [www.macromatic.com/onoff](http://www.macromatic.com/onoff) for information on how to order a unit with different ON & OFF time ranges.

\*\* Complete Product Number using two-digit Code from Table below.

## TIME DELAYS

TR-5 Series Products have three time delay options:

- **Onboard Adjustable Time Delay**--complete Product Number by adding two-digit Code from Table at right, i.e., TR-53122-05 is a Repeat Cycle with both an ON & OFF time delay range of 0.1-10 seconds. See [www.macromatic.com/onoff](http://www.macromatic.com/onoff) for information on how to order a unit with different ON & OFF time ranges.
- **Onboard Fixed Time Delay**--replace two-digit Code with suffix "F" followed by delay [0.1 ... 100] followed by (S) seconds, (M) minutes or (H) hours, i.e., TR-53122-F5S is a Repeat Cycle with a time delay fixed at 5 seconds.
- **Remote Time Delay**--Selected TR-5 Series products can be built with two terminals for remote adjustable or fixed time delays. See [www.macromatic.com/remot](http://www.macromatic.com/remot) for information.

\*\* TIMING RANGE TABLE

Time Delay Range	Code
0.05 - 5 Sec.	04
0.1 - 10 Sec.	05
0.3 - 30 Sec.	07✘
0.6 - 60 Sec.	08
1.2 - 120 Sec.	09
1.8 - 180 Sec.	10
3 - 300 Sec.	12
0.1 - 10 Min.	22
0.3 - 30 Min.	15
0.6 - 60 Min.	16✘
1.2 - 120 Min.	17✘

✘ Not offered on TR-546

Sockets & Accessories available

Build your Time Delay Relays with the [Online Product Builder](#)



Better. By Design.

800.238.7474

WWW.MACROMATIC.COM

SALES@MACROMATIC.COM

# TR-5 SERIES

## NON-PROGRAMMABLE

### APPLICATION DATA

#### Voltage Tolerance:

AC Operation: +10/-15% of nominal at 50/60 Hz.  
DC Operation: +10/-15% of nominal.

#### Load (Burden):

Maximum of 2 VA for all voltages

#### Setting Accuracy:

Maximum Setting (Adjustable): +5%, -0%  
Minimum Setting (Adjustable): +0%, -50%  
Fixed Time Delay: ±2% or 50ms, whichever is greater

#### Repeat Accuracy (constant voltage and temperature):

±0.1% or ± 0.04 seconds, whichever is greater

#### Reset Time:

Input Voltage (All Functions)	0.100 Seconds
Triggered Functions only	0.04 Seconds

#### Start-up Time:

(Time from when power is applied until unit is timing)  
0.05 Seconds

#### Maintain Function Time:

(Time unit continues to operate after power is removed)  
0.01 Seconds for all units

**Temperature:** Operating: -28° to 65°C (-18° to 149°F)  
Storage: -40° to 85°C (-40° to 185°F)

#### Output Contacts:

(All TR-5 Series Products except TR-506 & TR-546)  
DPDT 10A @ 240V AC/30V DC,  
1/2HP @ 120/240V AC (N.O.), 1/3HP @ 120/240V AC (N.C.)  
B300 & R300; AC15 & DC13

(TR-506 & TR-546)  
DPDT 10A @ 240V AC; 8A @ 28V DC,  
1/2 HP @ 240V AC, 1/4HP @ 120V AC  
B300 & R300

#### Life:

Mechanical: 10,000,000 operations (2,000,000 operations on TR-506 & TR-546 Series only)  
Full Load: 100,000 operations

#### Compatibility:

Using a solid state switch to initiate the time sequence is acceptable. See [www.macromatic.com/leakage](http://www.macromatic.com/leakage) or contact Macromatic for information regarding leakage current limits and other solid state design considerations.

#### Triggering Off Delay, Single Shot or Watchdog Units:

Timing sequence must be initiated only after input voltage is applied to unit. Minimum required trigger switch closure time is 0.05 seconds.

**IMPORTANT FOR TR-506 & TR-546 SERIES ONLY:** These relays are shipped from the factory in the OFF state. A shock to the relay during shipping or installation may cause it to change to the ON state. It is recommended that input voltage be applied to the product for at least 0.1 second and removed to cycle the unit to the OFF state prior to use in the application. Please note that it will take as long as the OFF Delay setting to reset the unit once input voltage has been removed.

#### Approvals:

(All TR-5 Series Products except TR-506 & TR-546)



(TR-506 & TR-546 only)



(All TR-5 Series Products)



### DIMENSIONS

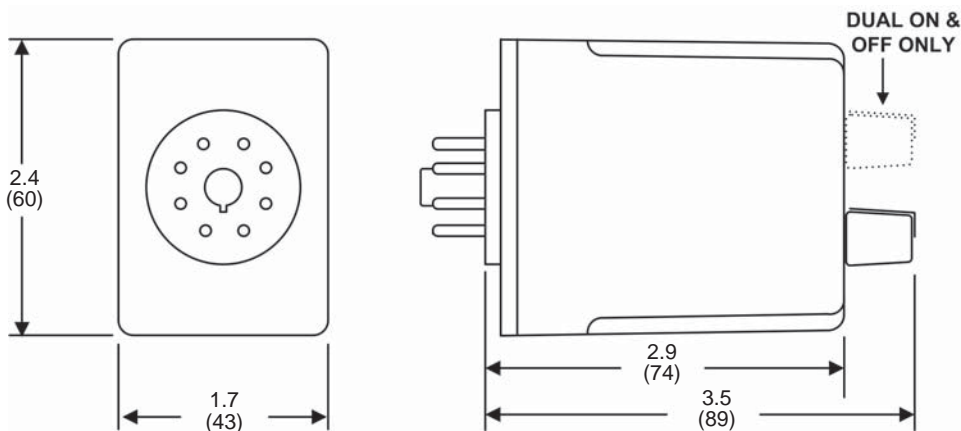

All Dimensions in Inches (Millimeters)

# NON-PROGRAMMABLE | OFF DELAY, SINGLE SHOT & WATCHDOG

## 8 PIN | SPDT VERSIONS | TR-5 SERIES



- ◆ These are 8 pin 10A SPDT versions of our standard 11 pin DPDT products
- ◆ Onboard & remote adjustable or fixed time delays from 0.05 seconds to 2 hours
- ◆ Uses industry-standard 8 pin octal socket

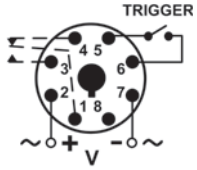
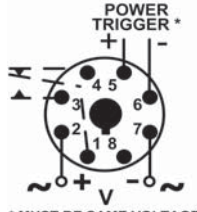

FUNCTION ■	INPUT VOLTAGE 50/60Hz.	PRODUCT NUMBER **	WIRING/SOCKETS ▲
<b>OFF DELAY</b> Control Switch Trigger <b>C</b>	120V AC/DC 12V DC 24V AC/DC 240V AC	TR-51662-** TR-51666-** TR-51668-** TR-51661-**	8 PIN OCTAL <b>70169-D ▲</b> 
<b>SINGLE SHOT</b> Control Switch Trigger <b>D</b>	120V AC/DC 12V DC 24V AC/DC 240V AC	TR-51562-** TR-51566-** TR-51568-** TR-51561-**	<b>DIAGRAM 11</b>
<b>WATCHDOG</b> Control Switch Trigger (Retriggerable Single Shot) <b>J</b>	120V AC/DC 12V DC 24V AC/DC 240V AC	TR-51362-** TR-51366-** TR-51368-** TR-51361-**	
<b>OFF DELAY</b> Power Trigger <b>C</b>	120V AC/DC 12V DC 24V AC/DC 240V AC	TR-51962-** TR-51966-** TR-51968-** TR-51961-**	
<b>SINGLE SHOT</b> PowerTrigger <b>D</b>	120V AC/DC 12V DC 24V AC/DC 240V AC	TR-51762-** TR-51766-** TR-51768-** TR-51761-**	<b>DIAGRAM 37</b> 
<b>WATCHDOG</b> Power Trigger (Retriggerable Single Shot) <b>J</b>	120V AC/DC 12V DC 24V AC/DC 240V AC	TR-51862-** TR-51866-** TR-51868-** TR-51861-**	

■ See "Definitions of Timing Functions".

\*\* Complete Product Number using two-digit Code from Table below.

▲ Note: if these products are ordered with the Remote Adjust Potentiometer modification (suffix -Rx), they will require an 11 pin octal socket—see [www.macromatic.com/remote](http://www.macromatic.com/remote) for information.

## TIME DELAYS

TR-5 Series Products have three time delay options:

- **Onboard Adjustable Time Delay**--complete Product Number by adding two-digit Code from Table at right, i.e., TR-51662-05 is an Off Delay with a time delay range of 0.1-10 seconds.
- **Onboard Fixed Time Delay**--replace two-digit Code with suffix "F" followed by delay [0.1 ... 100] followed by (S) seconds, (M) minutes or (H) hours, i.e., TR-51662-F5S is an Off Delay with a time delay fixed at 5 seconds.
- **Remote Time Delay**--Selected TR-5 Series products can be built with two terminals for remote adjustable or fixed time delays. See [www.macromatic.com/remote](http://www.macromatic.com/remote) for information.

** TIMING RANGE TABLE	
Time Delay Range	Code
0.05 - 5 Sec.	04
0.1 - 10 Sec.	05
0.3 - 30 Sec.	07
0.6 - 60 Sec.	08
1.2 - 120 Sec.	09
1.8 - 180 Sec.	10
3 - 300 Sec.	12
0.1 - 10 Min.	22
0.3 - 30 Min.	15
0.6 - 60 Min.	16
1.2 - 120 Min.	17

Sockets & Accessories available

Build your Time Delay Relays with the [Online Product Builder](#)



Better. By Design.

**800.238.7474**

[WWW.MACROMATIC.COM](http://WWW.MACROMATIC.COM)

[SALES@MACROMATIC.COM](mailto:SALES@MACROMATIC.COM)

# TR-5 SERIES

## 8 PIN | SPDT VERSIONS

### APPLICATION DATA

#### Voltage Tolerance:

AC Operation: +10/-15% of nominal at 50/60 Hz.  
DC Operation: +10/-15% of nominal.

#### Load (Burden):

Maximum of 2 VA for all voltages

#### Setting Accuracy:

Maximum Setting (Adjustable): +5%, -0%  
Minimum Setting (Adjustable): +0%, -50%  
Fixed Time Delay:  $\pm 2\%$  or 50ms, whichever is greater

**Repeat Accuracy** (constant voltage and temperature):  
 $\pm 0.1\%$  or  $\pm 0.04$  seconds, whichever is greater

#### Reset Time:

Input Voltage (All Functions) 0.100 Seconds  
Triggered Functions only 0.04 Seconds

#### Start-up Time:

(Time from when power is applied until unit is timing)  
0.05 Seconds

#### Maintain Function Time:

(Time unit continues to operate after power is removed)  
0.01 Seconds for all units

**Temperature:** Operating: -28° to 65°C (-18° to 149°F)  
Storage: -40° to 85°C (-40° to 185°F)

#### Output Contacts:

SPDT 10A @ 240V AC/30V DC,  
1/2HP @ 120/240V AC (N.O.), 1/3HP @ 120/240V AC (N.C.)  
B300 & R300; AC15 & DC13

#### Life:

Mechanical: 10,000,000 operations  
Full Load: 100,000 operations

#### Compatibility:

Using a solid state switch to initiate the time sequence is acceptable. See [www.macromatic.com/leakage](http://www.macromatic.com/leakage) or contact Macromatic for information regarding leakage current limits and other solid state design considerations.

#### Triggering Off Delay, Single Shot or Watchdog Units:

Timing sequence must be initiated only after input voltage is applied to unit. Minimum required trigger switch closure time is 0.05 seconds.

#### Approvals:



### DIMENSIONS

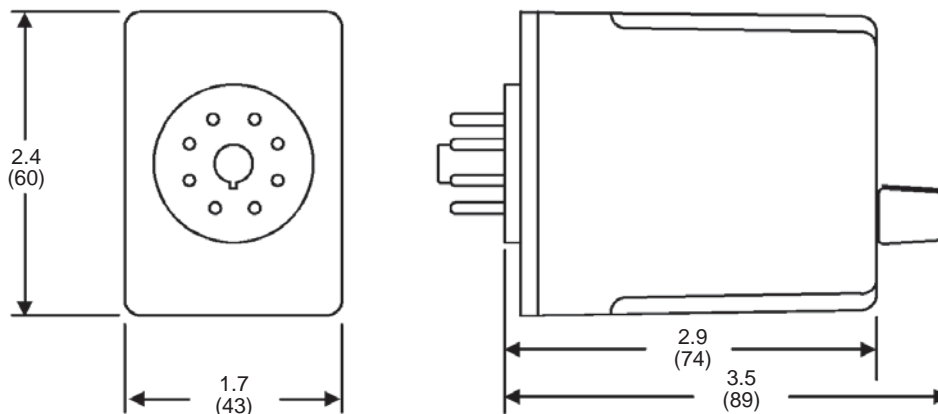

All Dimensions in  
Inches (Millimeters)

# DEFINITION OF TIMING FUNCTIONS

Understanding the differences between all the functions available in time delay relays can sometimes be a daunting task. To begin with, time delay relays are simply control relays with a time delay built in. Their purpose is to control an event based on time.

Typically, time delay relays are initiated or triggered by one of two methods, depending on the function:

- ◆ application of input voltage
- ◆ application of a trigger

These triggers can be one of two signals: a control switch (dry contact), i.e., limit switch, push button, float switch, etc., or voltage (commonly known as a power trigger).

**CAUTION: any time delay relay that is designed to be initiated with a dry contact control switch trigger could be damaged if voltage is applied to the trigger switch terminals. Only products that have a “power trigger” should be used with voltage as the trigger.**

To help understand, some definitions are important:

- ◆ **Input Voltage** - control voltage applied to the input terminals. Depending on the function, input voltage will either initiate the unit or make it ready to initiate when a trigger is applied.
- ◆ **Trigger**- on certain timing functions, a trigger is used to initiate the unit after input voltage has been applied. As noted above, this trigger can either be a control switch (dry contact switch) or a power trigger (voltage).
- ◆ **Output (Load)** - every time delay relay has an output (either mechanical relay or solid state) that will open & close to control the load. Note that the user must provide the voltage to power the load being switched by the output contacts of the time delay relay. In all wiring diagrams, the output is shown in the normal de-energized position.

Below and on the following pages are both written and visual descriptions on how the common timing functions operate. A Timing Chart shows the relationship between Input Voltage, Trigger (if present) and Output. If you cannot find a product to fit your requirements or have any questions, Macromatic's Application Engineers offer technical information along with product selection and application assistance. Call us at 800-238-7474 or e-mail us [tech-help@macromatic.com](mailto:tech-help@macromatic.com).

Function/Code	Operation	Timing Chart
<b>ON DELAY</b> Delay on Operate Delay on Make <b>A</b>	Upon application of input voltage, the time delay (t) begins. At the end of the time delay (t), the output is energized. Input voltage must be removed to reset the time delay relay & de-energize the output..	
<b>INTERVAL ON</b> Interval <b>B</b>	Upon application of input voltage, the output is energized and the time delay (t) begins. At the end of the time delay (t), the output is de-energized. Input voltage must be removed to reset the time delay relay.	
<b>OFF DELAY</b> Delay on Release Delay on Break Delay on De-Energization <b>C</b>	Upon application of input voltage, the time delay relay is ready to accept a trigger. When the trigger is applied, the output is energized. Upon removal of the trigger, the time delay (t) begins. At the end of the time delay (t), the output is de-energized. Any application of the trigger during the time delay will reset the time delay (t) and the output remains energized.	
<b>SINGLE SHOT</b> One Shot Momentary Interval <b>D</b>	Upon application of input voltage, the time delay relay is ready to accept a trigger. When the trigger is applied, the output is energized and the time delay (t) begins. During the time delay (t), the trigger is ignored. At the end of the time delay (t), the output is de-energized and the time delay relay is ready to accept another trigger.	

# DEFINITION OF TIMING FUNCTIONS

Function/Code	Operation	Timing Chart
<b>FLASHER (Off First)</b> <b>E</b>	Upon application of input voltage, the time delay ( $t$ ) begins. At the end of the time delay ( $t$ ), the output is energized and remains in that condition for the time delay ( $t$ ). At the end of the time delay ( $t$ ), the output is de-energized and the sequence repeats until input voltage is removed.	
<b>FLASHER (ON First)</b> <b>F</b>	Upon application of input voltage, the output is energized and the time delay ( $t$ ) begins. At the end of the time delay ( $t$ ), the output is de-energized and remains in that condition for the time delay ( $t$ ). At the end of the time delay ( $t$ ), the output is energized and the sequence repeats until input voltage is removed.	
<b>ON/OFF DELAY</b> <b>G</b>	Upon application of input voltage, the time delay relay is ready to accept a trigger. When the trigger is applied, the time delay ( $t_1$ ) begins. At the end of the time delay ( $t_1$ ), the output is energized. When the trigger is removed, the output contacts remain energized for the time delay ( $t_2$ ). At the end of the time delay ( $t_2$ ), the output is de-energized & the time delay relay is ready to accept another trigger. If the trigger is removed during time delay period ( $t_1$ ), the output will remain de-energized and time delay ( $t_1$ ) will reset. If the trigger is removed during time delay period ( $t_2$ ), the output will remain energized and the time delay ( $t_2$ ) will reset.	
<b>SINGLE SHOT FALLING EDGE</b> <b>H</b>	Upon application of input voltage, the time delay relay is ready to accept a trigger. When the trigger is applied, the output remains de-energized. Upon removal of the trigger, the output is energized and the time delay ( $t$ ) begins. At the end of the time delay ( $t$ ), the output is de-energized unless the trigger is removed and re-applied prior to time out (before time delay ( $t$ ) elapses). Continuous cycling of the trigger at a rate faster than the time delay ( $t$ ) will cause the output to remain energized indefinitely.	
<b>WATCHDOG Retriggerable Single Shot</b> <b>J</b>	Upon application of input voltage, the time delay relay is ready to accept a trigger. When the trigger is applied, the output is energized and the time delay ( $t$ ) begins. At the end of the time delay ( $t$ ), the output is de-energized unless the trigger is removed and re-applied prior to time out (before time delay ( $t$ ) elapses). Continuous cycling of the trigger at a rate faster than the time delay ( $t$ ) will cause the output to remain energized indefinitely.	
<b>TRIGGERED ON DELAY</b> <b>K</b>	Upon application of input voltage, the time delay relay is ready to accept a trigger. When the trigger is applied, the time delay ( $t$ ) begins. At the end of the time delay ( $t$ ), the output is energized and remains in that condition as long as either the trigger is applied or the input voltage remains. If the trigger is removed during the time delay ( $t$ ), the output remains de-energized & the time delay ( $t$ ) is reset.	



# DEFINITION OF TIMING FUNCTIONS

Function/Code	Operation	Timing Chart
<b>REPEAT CYCLE (OFF 1st)</b> <b>L</b>	Upon application of input voltage, the time delay (t1) begins. At the end of the time delay (t1), the output is energized and remains in that condition for the time delay (t2). At the end of this time delay, the output is de-energized and the sequence repeats until input voltage is removed.	
<b>REPEAT CYCLE (ON 1st)</b> <b>M</b>	Upon application of input voltage, the output is energized and the time delay (t1) begins. At the end of the time delay (t1), the output is de-energized and remains in that condition for the time delay (t2). At the end of this time delay, the output is energized and the sequence repeats until input voltage is removed.	
<b>DELAYED INTERVAL Single Cycle</b> <b>N</b>	Upon application of input voltage, the time delay (t1) begins. At the end of the time delay (t1), the output is energized and remains in that condition for the time delay (t2). At the end of this time delay (t2), the output is de-energized. Input voltage must be removed to reset the time delay relay.	
<b>TRIGGERED DELAYED INTERVAL</b> <b>P</b>	Upon application of input voltage, the time delay relay is ready to accept a trigger. When the trigger is applied, the time delay (t1) begins. At the end of the time delay (t1), the output is energized and remains in that condition for the time delay (t2). At the end of this time delay (t2), the output is de-energized & the relay is ready to accept another trigger. During both time delay (t1) & time delay (t2), the trigger is ignored.	
<b>TRUE OFF DELAY</b> <b>R</b>	Upon application of input voltage, the output is energized. When the input voltage is removed, the time delay (t) begins. At the end of the time delay (t), the output is de-energized. Input voltage must be applied for a minimum of 0.5 seconds to assure proper operation. Any application of the input voltage during the time delay (t) will reset the time delay. No external trigger is required.	
<b>ON DELAY/ TRUE OFF DELAY</b> <b>S</b>	Upon application of input voltage, the time delay (t1) begins. At the end of the time delay (t1), the output is energized. When the input voltage is removed, the output remains energized for the time delay (t2). At the end of the time delay (t2), the output is de-energized. Input voltage must be applied for a minimum of 0.5 seconds to assure proper operation. Any application of the input voltage during the time delay (t2) will keep the output energized & reset the time delay (t2). No external trigger is required.	
<b>SINGLE SHOT-FLASHER</b> <b>T</b>	Upon application of input voltage, the time delay relay is ready to accept a trigger. When the trigger is applied, the time delay (t1) begins and the output is energized for the time delay (t2). At the end of this time delay (t2), the output is de-energized and remains in that condition for the time delay (t2). At the end of the time delay (t2), the output is energized and the sequence repeats until time delay (t1) is completed. During the time delay (t1), the trigger is ignored.	
<b>ON DELAY-FLASHER</b> <b>X</b>	Upon application of input voltage, the time delay begins (t1). At the end of the time delay (t1), the output is energized and remains in that condition for the time delay (t2). At the end of this time delay (t2), the output is de-energized and remains in that condition for the time delay (t2). At the end of the time delay (t2), the output is energized and the sequence repeats until input voltage is removed.	

# SOCKETS & ACCESSORIES

## 8 Pin Octal Socket- Surface or DIN Rail-Mounted

10A @ 600V  
1 or 2 #12-22 AWG Wire  
Recommended Tightening Torque  
of 7 in-lbs. (12 in-lbs maximum)  
Pressure Wire Clamp Terminations



File #E169693 File #LR701114

## Catalog Number 70169-D

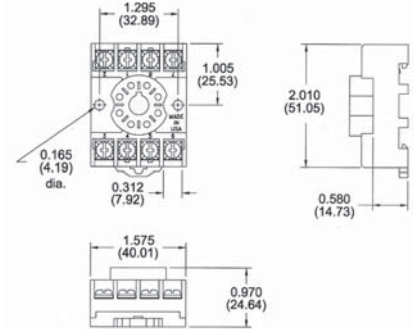

## 11 Pin Octal Socket- Surface or DIN Rail-Mounted

10A @ 300V  
1 or 2 #12-22 AWG Wire  
Recommended Tightening Torque  
of 7 in-lbs. (12 in-lbs maximum)  
Pressure Wire Clamp Terminations



File #E169693 File #LR701114

## Catalog Number 70170-D

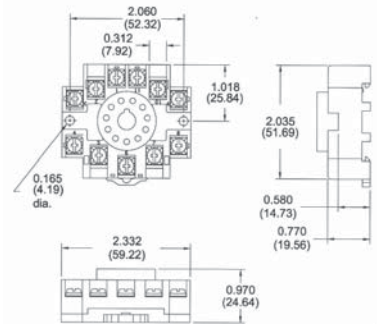

## 8 Pin Octal Socket- Back-Mounted

10A @ 300V  
Pressure Wire Clamp Terminations



File #E62437

## Catalog Number SR6P-M08G

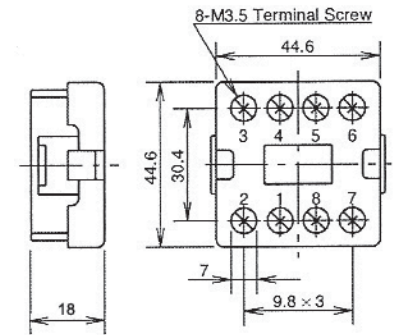

## 11 Pin Octal Socket- Back-Mounted

10A @ 300V  
Pressure Wire Clamp Terminations



File #E62437

## Catalog Number SR6P-M11G

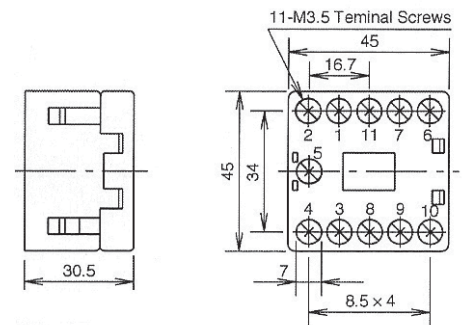

# SOCKETS & ACCESSORIES

## Hold Down Spring Catalog Number 70166

Can be used for:

- ◆ Panel-Mounted Sockets
  - ◆ Sockets Mounted to 35mm DIN Rail \*
- \* Requires two machine screws with washers & nuts-- contact Macromatic or [www.macromatic.com/70166](http://www.macromatic.com/70166) for more information.



## DIN Rail Adaptor Kit Catalog Number 70500

Quick & Economical Way to Install Any THx Series 2" x 2" Encapsulated Time Delay Relays on 35mm DIN Rail

- ◆ Clip Comes with a Threaded Hole to Eliminate Need for a Washer & Nut
- ◆ All Mounting Hardware Included



## X-ON Electronics

Largest Supplier of Electrical and Electronic Components

*Click to view similar products for [Time Delay & Timing Relays](#) category:*

*Click to view products by [Macromatic](#) manufacturer:*

Other Similar products are found below :

[7012GD](#) [7012L10BN](#) [7012L10DY1N](#) [7012L10FN](#) [7012L10HN](#) [7012L26K](#) [7012L8AI2LLSN](#) [7012L8BN](#) [7012L8KN](#) [7012OBILM](#)  
[7012OIT](#) [7012PALL](#) [7012PDM](#) [7012PFX](#) [7022L10DN](#) [7022L8BN](#) [7022L8EN](#) [7022L8HN](#) [7022X3D](#) [7024NB](#) [7024SCT](#) [88256455](#) [H3BG-](#)  
[N8H](#) [AC110V](#) [H3CRF8AC2448DC1248](#) [1423151-3](#) [1423154-8](#) [1423462-7](#) [1423618-6](#) [1423151-5](#) [1423156-7](#) [1423618-4](#) [2112AH1SDC947](#)  
[2122DH1NJC467](#) [2122DH1PE](#) [2-1617805-2](#) [2-1617805-6](#) [K61C-08](#) [286XCXC-300-24D](#) [SCBRX022XXACXAC991](#) [SHS10S110A](#)  
[SHS20M220A](#) [1755074-5](#) [SSC12AKA](#) [FAASPRING2](#) [2112DH3NDC50-13](#) [2122DH34NDC629](#) [2-1437479-8](#) [2-1617805-1](#) [2-1617805-3](#) [2-](#)  
[1617805-7](#)