

APPROVAL SHEET

(RoHS Compliant & Halogen Free)

CUSTOMER : _____

CUSTOMER'S PART NO. : _____

DESCRIPTION : **Multi-layer Chip Diplexer for LTE**

PART NO. : **LTD-1608-DFXJS-A1**

DATE : _____

AUTHORIZED BY : *Derek Wei*

	FULLY APPROVED	PARTIALLY APPROVED	REJECTED
SIGN			
SUGGESTION			

美磊科技股份有限公司

MAG. LAYERS SCIENTIFIC-TECHNICS CO., LTD

HEAD OFFICE / PINGZHEN PLANT

270, Nan-Feng Road, Pingzhen District, Taoyuan City, Taiwan

TEL: 886-3-4159111 FAX: 886-3-4192255

http : //www.maglayers.com.tw

E-mail : info@maglayers.com.tw

Revision History

Version	Date	Description	Approved by	Prepared by
1	2018/12/06	Initial specification.	CF	LYW
2	2020/03/17	Modify recommended PCB layout and land pattern.	CF	LYW
3	2020/04/17	Modify electrical requirements.	CF	LYW

APPLICATION

GSM/WCDMA/LTE mobile communication systems.

FEATURES

- **Compact Size**
Miniaturized SMD packaged in low profile and lightweight.
- **Low loss**
Low insertion loss, high attenuation.
- **High Soldering Heat Resistance**
High quality termination allows both flow and re-flow soldering methods to be applied.
- **Characteristics**
Eliminate noise over a wide frequency range. Idea for high frequency and space limited designs.
- **Available in tape and reel packaging for automatic mounting**

PRODUCT IDENTIFICATION

L T D - 1 6 0 8 - ### x x - A 1 - □ □
① ② ③ ④ ⑤

- ① Product Code
- ② Dimension Code
- ③ Series Type (### represents center frequency and xx represents material type)
- ④ Design Code
- ⑤ Pattern Code

ELECTRICAL REQUIREMENTS

Low-Band

Item	Frequency Range(MHz)	Min.	Typ.	Max.
Insertion Loss (dB)	698~960	—	0.75	0.90
Return Loss (dB)	698~960	10	18.5	—
Attenuation (dB)	1710~2700	25	30	—

High-Band

Item	Frequency Range(MHz)	Min.	Typ.	Max.
Insertion Loss (dB)	1710~2700	—	0.65	0.80
Return Loss (dB)	1710~2700	10	17	—
Attenuation (dB)	698~960	20	26.5	—
	5150~5850	20	22	—

Common

Item	Frequency Range(MHz)	Min.	Typ.	Max.
Return Loss (dB)	698~960	10	17	—
	1710~2700	10	17	—

Isolation

Item	Frequency Range(MHz)	Min.	Typ.	Max.
Low to High (dB)	698~960	20	27	—
	1710~2700	25	30	—

Operating Temperature Range: -40 ~ +85°C

Power Capacity: 3W max.

PRODUCT DIMENSION

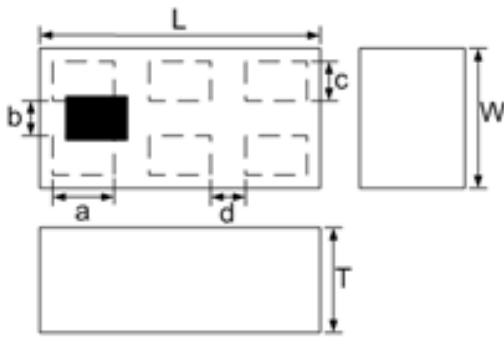

L	W	T	a
1.60±0.10	0.80±0.10	0.60±0.10	0.35±0.10
d	b	c	
0.22±0.05	0.20±0.10	0.22±0.05	

NOTE : Dimensions in mm

TERMINAL CONFIGURATION

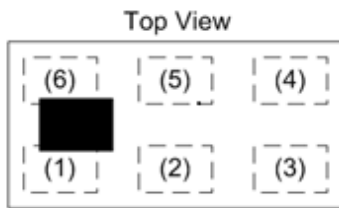

- (1) GND
- (2) Common Port
- (3) GND
- (4) High Frequency Port
- (5) GND
- (6) Low Frequency Port

MEASURING DIAGRAM

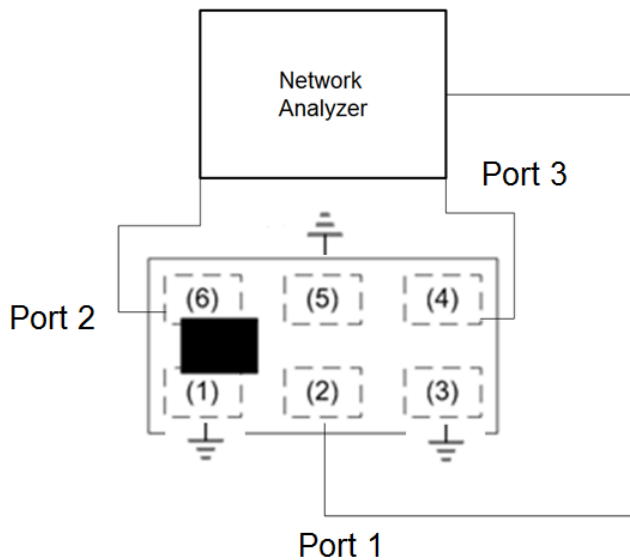

Test Instrument:
Agilent E5071C Network Analyzer or equivalent.

RECOMMENDED PCB LAYOUT AND LAND PATTERN

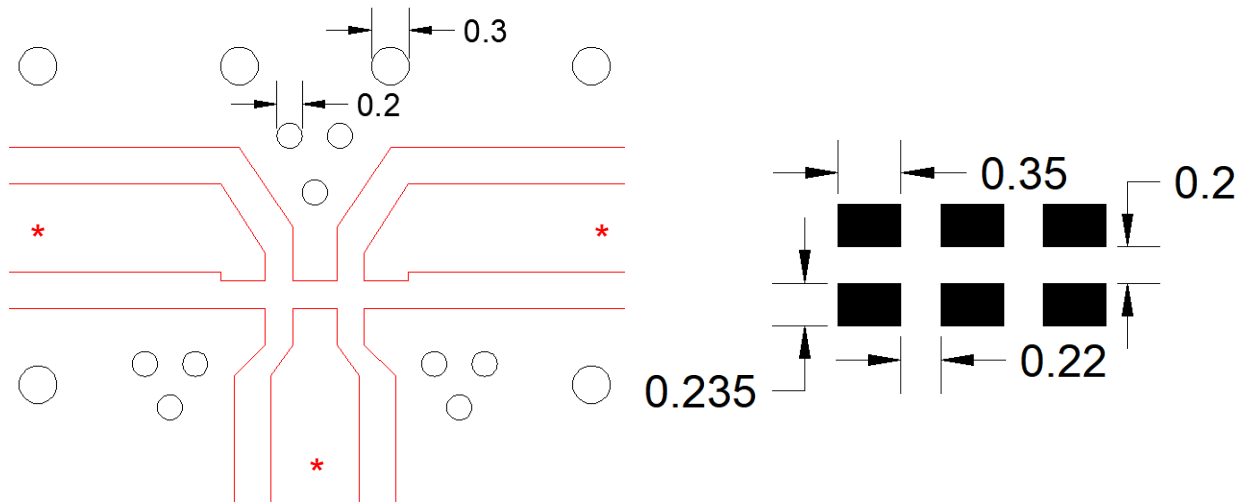

unit: mm

*Line width should be designed to match 50Ω characteristic impedance, depending on PCB material and thickness.

ELECTRICAL CHARACTERISTICS (T=25°C)

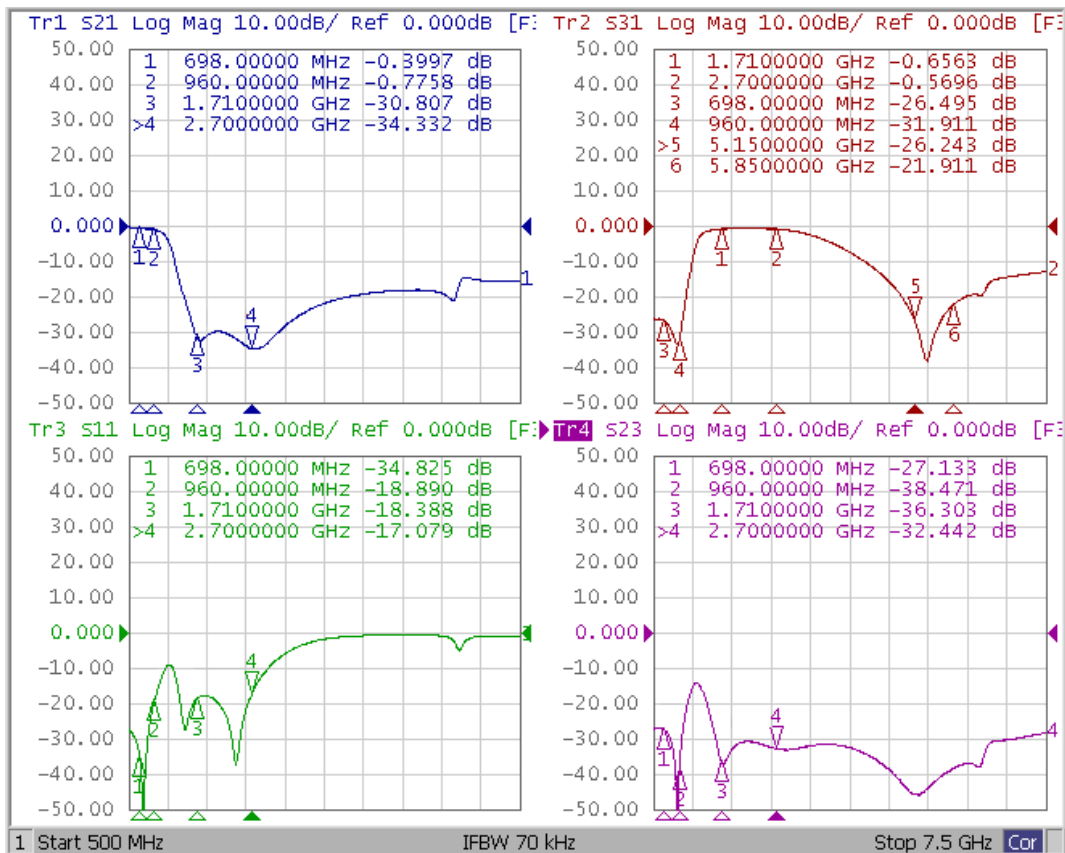

RELIABILITY TEST

Mechanical Test

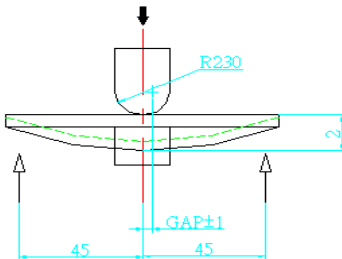
Item	Test Condition	Specification
Vibration	10 Hz/min~55 Hz/min~10 Hz/min vibration frequency with 1.5 mm amplitude for two hours in x, y, z directions	No apparent damage
Drop shock	Dropped onto printed circuit board from 100cm height three times in x, y, z directions. The terminals shall be protected.	No apparent damage
Soldering heat resistance	Preheating temperature : $150\pm 10^{\circ}\text{C}$ Preheating time : 1 to 2 minutes Solder bath temperature : $260\pm 5^{\circ}\text{C}$ Bathing time : 5 ± 0.5 seconds	No apparent damage
Bending test onto printed circuit board	<p>Solder specimen LTCC components on the test printed circuit board (L: 100 x W: 40 x T: 1.6mm) in appended recommended PCB pattern. Apply the load in direction of the arrow until bending reaches 2 mm.</p>  <p style="text-align: right;">Unit: mm</p>	No apparent damage
Solderability	The dipped surface of the terminal shall be at least 75% covered with solder after dipped in solder bath of $245\pm 5^{\circ}\text{C}$ for 3 ± 0.5 seconds.	No apparent damage

Environment Test

Thermal shock	-40°C ~ $+85^{\circ}\text{C}$ for 100 cycles each cycle being 30 min	No apparent damage Fulfill the electrical spec. after test
Humidity resistance	$85\pm 2^{\circ}\text{C}$, 80~90% R.H. for 500 hours	No apparent damage Fulfill the electrical spec. after test
High temperature resistance	$85\pm 2^{\circ}\text{C}$ for 500 hours	No apparent damage Fulfill the electrical spec. after test
Low temperature resistance	$-40\pm 3^{\circ}\text{C}$ for 500 hours	No apparent damage Fulfill the electrical spec. after test

PACKAGING FOR SMC

Peel-off force

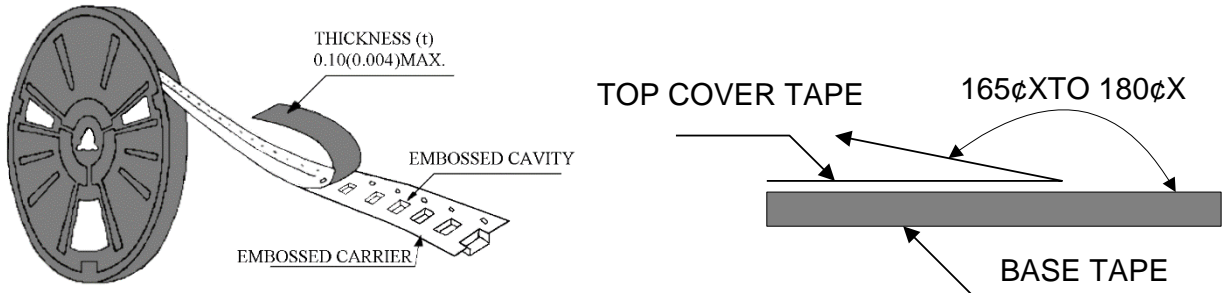

The force for peeling off cover tape is 10 grams in the arrow direction.

Dimension (Unit: mm)

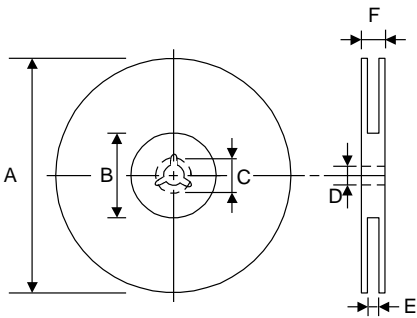

TYPE	A	B	C	D	E	F
8 mm	178±1	60+0.5 -0	-	13±0.2	9±0.5	12±0.5
12 mm	178±0.3	60±0.2	19.3±0.1	13.5±0.1	13.6±0.1	-

Taping quantity

SERIES	5824 5724	5320 5220	4532	4516	3225	3216 2520	2012 1608	1005
PCS/Reel	5000	3000	1000	2000	2500	3000	4000	10000

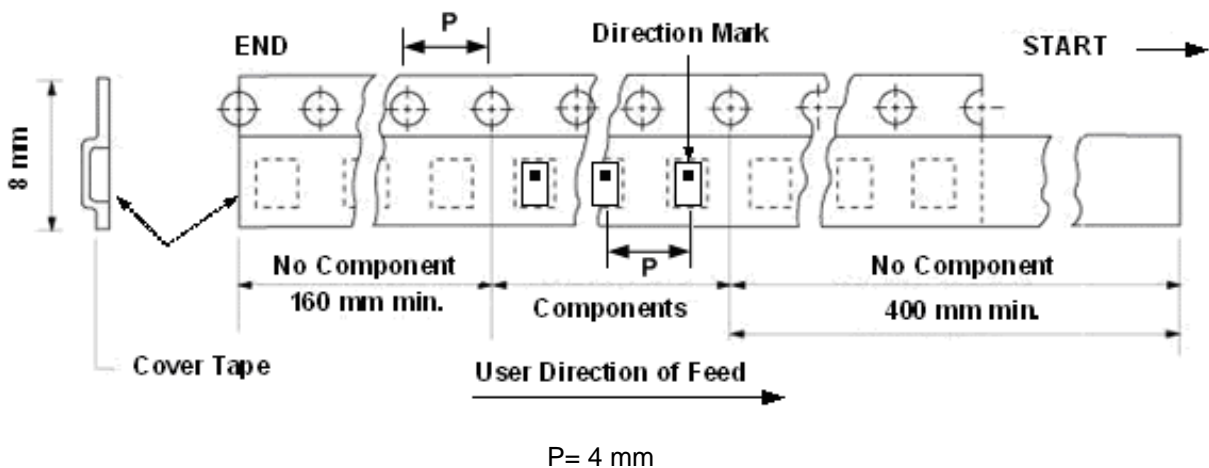

TAPE PACKING CASE

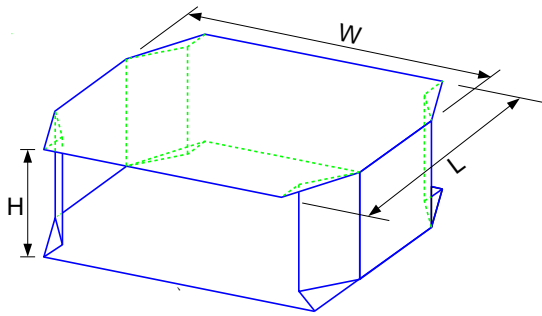

Unit:cm

No. of Reels	W	L	H
2	18±0.5	18±0.5	2.4±0.2
3	18±0.5	18±0.5	3.6±0.2
4	18±0.5	18±0.5	4.8±0.2
5	18±0.5	18±0.5	6.0±0.2

OPERATION TEMPERATURE

-40°C~+85°C

STORAGE CONDITION

The temperature should be within -40 ~ 85°C and humidity should be less than 75% RH. The product should be used within 6 months from the time of delivery.

ATTENTION REGARDING PCB BENDING

- (a) PCB shall be designed so that products are not subjected to the mechanical stress for board warpage. Product shall be located in the sideways direction to the mechanical stress.

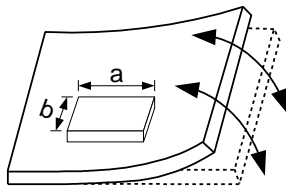

(Poor example)

Length: $a > b$

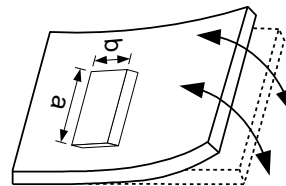

(Good example)

- (b) Products (A,B,C,D) shall be located carefully so that products are not subjected to the mechanical stress due to warping the board. Because they may be subjected to the mechanical stress in order of $A > C > B \approx D$.

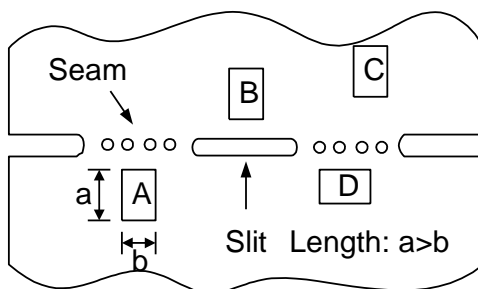

RECOMMENDED REFLOW SOLDERING PROFILE

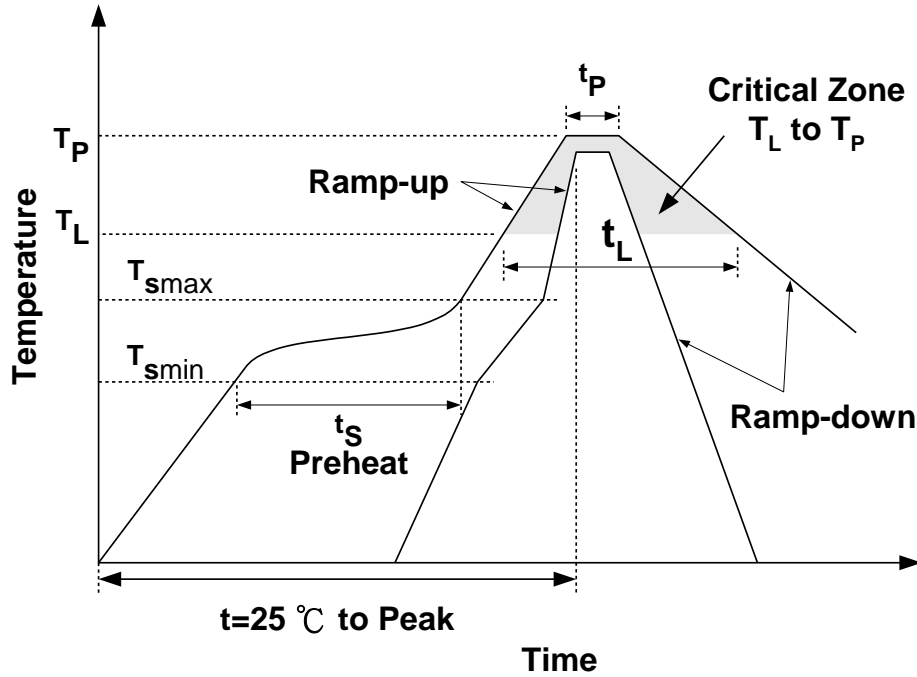

Profile Feature		Sn-Pb	Pb-Free
Preheat	t_s	60~120 seconds	60~180 seconds
	T_{smin}	100°C	150°C
	T_{smax}	150°C	200°C
Average ramp-up rate (T_{smax} to T_P)		3°C/second max.	3°C/second max.
Time main above	Temperature (T_L)	183°C	217°C
	Time (t_L)	60~150 seconds	60~150 seconds
Peak temperature (T_P)		230°C	250~260°C
Time within 5°C of actual peak temperature (t_P)		10 seconds	10 seconds
Ramp-down rate		6°C/sec max.	6°C/sec max.
Time 25°C to peak temperature		6 minutes max.	8 minutes max.

NOTES

The contents of this data sheet are subject to change without notice. Please confirm the specifications and delivery conditions when placing your order.

X-ON Electronics

Largest Supplier of Electrical and Electronic Components

Click to view similar products for [Signal Conditioning](#) category:

Click to view products by [MAGLAYERS](#) manufacturer:

Other Similar products are found below :

[PD0409J5050S2HF](#) [HHS-109-PIN](#) [AFS14A35-1591.50-T3](#) [JP510S](#) [LFB322G45SN1A504](#) [SF2159E](#) [FM-104-PIN](#) [CER0813B](#)
[MAPDCC0005](#) [3A325](#) [BD0810N50100AHF](#) [DC0710J5005AHF](#) [DC2327J5005AHF](#) [LFL15869MTC1B787](#) [X3C19F1-20S](#)
[CDBLB455KCAX39-B0](#) [RF1353C](#) [051157-0000](#) [PD0922J5050D2HF](#) [600S150FTRB](#) [1E1305-3](#) [1F1304-3S](#) [TP-103-PIN](#)
[BD1222J50200AHF](#) [BD1722J50100AHF](#) [2450DP39K5400E](#) [BD0810J50150AHF](#) [BD1722J50200AHF](#) [DS-327-PIN](#) [MACP-008125-](#)
[CK07F0](#) [DS-329-PIN](#) [DS-313-PIN](#) [TP-104-PIN](#) [TP-101-PIN](#) [HH-128-PIN](#) [8594810000](#) [T-1000-N](#) [JP506S](#) [XC0900P-10S](#) [XC0900B-30S](#)
[CHE1260-QAG](#) [11305-10](#) [5962-9091202MXA](#) [3A412S](#) [X3C06A4-03S](#) [B39000Z3410A4](#) [DSS-333-PIN](#) [PD2425J5050S2HF](#)
[B39242B4360P810](#) [B39781B8005P810](#)