

REVISIONS

REV.	Description	Date	Approved by	Checked by	Checked by	Prepared by
00	Preliminary release		Alfa	Vincent	Vivian	Menghua



I . SCOPE :

This specification applies to the Pb Free high current type SMD inductors for

MMD-10DZ-SERIES□- □□

PRODUCT IDENTIFICATION

MMD - 10DZ - 3R3 □ □- □□

① ② ③ ④ ⑤

- ① Product Code
- ② Dimensions Code
- ③ Inductance Code
- ④ Tolerance Code
- ⑤ Inner Control Code

II . INDEX :

LISTED ITEM	ATTACHEMENT & TABLES	PAGE
1. SHAPES AND DIMENSIONS	Please see (1)	2/9
2. MATERIALS	Please see (3)	2/9
3. ELECTRICAL SPECIFICATIONS	Please see (2)	2/9 , 3/9
4. CHARACTERISTICS	Please see (3)	2/9 , 3/9
5. RELIABILITY TEST METHOD	Please see (4)	4/9 , 5/9 , 6/9
6. LAND DIMENSION (Ref.)	Please see (5)	7/9
7. PACKAGING	Please see (6)	8/9 , 9/9
8. STANDARD TEST CONDITIONS Unless otherwise specified, test condition should be Temp. =20±5°C, Humidity=35~85% But if needed, then test condition should be Temp. =20±2°C, Humidity=65±5%		
9. SHELF LIFE Storage Condition:The temperature should be within-40°C ~105°C and humidity should be less than 75%RH. The product should be used within 12 months from the time of delivery. In addition, suggest to use product within 6 months from the time of delivery.		



(1) SHAPES AND DIMENSIONS

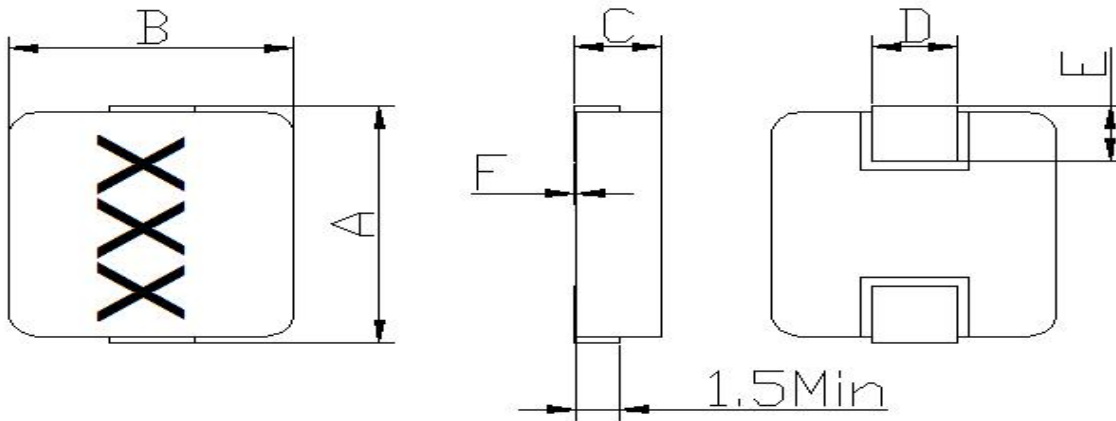

A: 11.2±0.3	mm	E: 2.0±0.5	mm
B: 10.2±0.3	mm		
C: 4.0Max.	mm		
D: 3.0 ref	mm		

(2) ELECTRICAL SPECIFICATIONS

SEE TABLE 1

TEST INSTRUMENTS

L : HP 4284A PRECISION LCR METER (or equivalent)

RDC : CHROMA MODEL 16502 MILLIOHM METER (or equivalent)

(3) CHARACTERISTICS

(3)-1 Operate temperature range -40°C~+125°C
(Including self temp. rise)

(3)-2 Storage temperature range -40°C~+125°C

MATERIALS

NO.	ITEM	DESCRIPTION & TYPE	UL NO.	MANUFACTURER
1	CORE	FERRITE		JIANGXI YUEAN
2	WIRE	POLYURETHANE ENAMELLED COPPER WIRE	E258243	ELEKTRISOLA CO., LTD.
			E84081	PACIFIC ELECTRICAL WIRE & CABLE CO., LTD.
3	SOLDER	Sn99.3%/Cu0.7%		SOLENT METAL INDUSTRY CO., LTD.
				DONGGUAN ZHONGSHUN



MAG.LAYERS

Contents

TABLE 1

MAGLAYERS PT/NO.	Inductance L(μ H)	Percent Tolerance	L Test Frequency		Resistance RDC($m\Omega$)MAX	Rated DC Current	
						Idc(A)	Isat(A)
MMD-10DZ-R22□□- □□	0.22	M, N	100KHz/0.25V		1.80	30.000	50.000
MMD-10DZ-R36□□- □□	0.36	M, N	100KHz/0.25V		2.10	28.000	45.000
MMD-10DZ-R68□□- □□	0.68	M, N	100KHz/0.25V		2.70	21.000	30.000
MMD-10DZ-1R0□□- □□	1.00	M, N	100KHz/0.25V		4.50	18.000	25.000
MMD-10DZ-1R2□□- □□	1.20	M, N	100KHz/0.25V		5.00	15.000	23.000
MMD-10DZ-2R2□□- □□	2.20	M, N	100KHz/0.25V		8.00	12.000	18.000
MMD-10DZ-2R7□□- □□	2.70	M, N	100KHz/0.24V		10.00	11.000	16.000
MMD-10DZ-3R3□□- □□	3.30	M, N	100KHz/0.25V		12.00	11.000	16.000
MMD-10DZ-4R7□□- □□	4.70	M, N	100KHz/0.25V		18.00	9.000	14.000
MMD-10DZ-5R6□□- □□	5.60	M, N	100KHz/0.25V		22.00	7.000	12.000
MMD-10DZ-8R2□□- □□	8.20	M, N	100KHz/0.26V		30.00	5.500	8.000
MMD-10DZ-220□□- □□	22.00	M, N	100KHz/0.25V		80.00	4.500	7.000
MMD-10DZ-330□□- □□	33.00	M, N	100KHz/0.25V		91.00	4.440	5.050
MMD-10DZ-470□□- □□	47.00	M, N	100KHz/0.25V		155.00	1.500	2.500

※ □ specify the inductance tolerance , M(\pm 20%) , N(\pm 30%)

※ Isat : Based on inductance change (Δ L/Lo : drop 30% Max.) @ ambient temp. 25°C

Idc : Based on temperature rise (Δ T : 40°C Typ.)

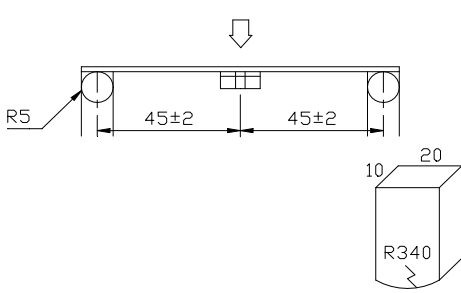

(4) RELIABILITY TEST METHOD
MECHANICAL

TEST ITEM	SPECIFICATION	TEST DETAILS
Substrate bending	$\Delta L/L_0 \leq \pm 5\%$ There shall be no mechanical damage or electrical damage.	<p>The sample shall be soldered onto the printed circuit board in figure 1 and a load applied until the figure in the arrow direction is made approximately 3mm. (keep time 30 seconds) PCB dimension shall be the page 7/9</p> <p style="text-align: center;">F(Pressurization)</p>  <p style="text-align: center;">PRESSURE ROD figure-1</p>
Vibration	$\Delta L/L_0 \leq \pm 5\%$ There shall be no mechanical damage.	<p>The sample shall be soldered onto the printed circuit board and when a vibration having an amplitude of 1.52mm and a frequency of from 10 to 55Hz/1 minute repeated should be applied to the 3 directions (X,Y,Z) for 2 hours each. (A total of 6 hours)</p>
Solderability	New solder More than 90%	<p>Flux (rosin, isopropyl alcohol{JIS-K-1522}) shall be coated over the whole of the sample before hard, the sample shall then be preheated for about 2 minutes in a temperature of 130~150°C and after it has been immersed to a depth 0.5mm below for 3±0.2 seconds fully in molten solder M705 with a temperature of 245±5°C.</p> <p>More than 90% of the electrode sections shall be covered with new solder smoothly when the sample is taken out of the solder bath.</p>



MECHANICAL

TEST ITEM	SPECIFICATION	
Resistance to Soldering heat (reflow soldering)	There shall be no damage or problems.	<p style="text-align: center;">Temperature profile of reflow soldering</p> <p>The specimen shall be passed through the reflow oven with the condition shown in the above profile for 1 time. The specimen shall be stored at standard atmospheric conditions for 1 hour, after which the measurement shall be made.</p>

ELECTRICAL

TEST ITEM	SPECIFICATION	TEST DETAILS
Insulation resistance	There shall be no other damage or problems.	DC 100V voltage shall be applied across this sample of top surface and the terminal. The insulation resistance shall be more than $1 \times 10^8 \Omega$.
Dielectric withstand voltage	There shall be no other damage or problems.	AC 100V voltage shall be applied for 1 minute across the top surface and the terminal of this sample
Temperature characteristics	$\Delta L/L20^\circ\text{C} \leq \pm 10\%$ 0~2000 ppm/°C	The test shall be performed after the sample has stabilized in an ambient temperature of -20 to +85°C, and the value calculated based on the value applicable in a normal temperature and normal humidity shall be $\Delta L/L20^\circ\text{C} \leq \pm 10\%$.



MAG.LAYERS

ENVIROMENT CHARACTERISTICS

TEST ITEM	SPECIFICATION																
High temperature storage	$\Delta L/Lo \leq \pm 5\%$ There shall be no mechanical damage.	The sample shall be left for 96 ± 4 hours in an atmosphere with a temperature of 125°C and a normal humidity. Upon completion of the measurement shall be made after the sample has been left in a normal temperature and normal humidity for 1 hour.															
Low temperature storage	$\Delta L/Lo \leq \pm 5\%$ There shall be no mechanical damage.	The sample shall be left for 96 ± 4 hours in an atmosphere with a temperature of $-25 \pm 3^\circ\text{C}$. Upon completion of the test, the measurement shall be made after the sample has been left in a normal temperature and normal humidity for 1 hour.															
Change of temperature	$\Delta L/Lo \leq \pm 5\%$ There shall be no other damage of problems	The sample shall be subject to 5 continuous cycles, such as shown in the table 2 below and then it shall be subjected to standard atmospheric conditions for 1 hour, after which measurement shall be made. <div style="text-align: center;"> table 2 <table border="1" data-bbox="678 913 1193 1276"> <thead> <tr> <th></th> <th>Temperature</th> <th>Duration</th> </tr> </thead> <tbody> <tr> <td>1</td> <td>$-25 \pm 3^\circ\text{C}$ (Thermostat No.1)</td> <td>30 min.</td> </tr> <tr> <td>2</td> <td>Standard atmospheric</td> <td>No.1→No.2</td> </tr> <tr> <td>3</td> <td>$85 \pm 2^\circ\text{C}$ (Thermostat No.2)</td> <td>30 min.</td> </tr> <tr> <td>4</td> <td>Standard atmospheric</td> <td>No.2→No.1</td> </tr> </tbody> </table> </div>		Temperature	Duration	1	$-25 \pm 3^\circ\text{C}$ (Thermostat No.1)	30 min.	2	Standard atmospheric	No.1→No.2	3	$85 \pm 2^\circ\text{C}$ (Thermostat No.2)	30 min.	4	Standard atmospheric	No.2→No.1
	Temperature	Duration															
1	$-25 \pm 3^\circ\text{C}$ (Thermostat No.1)	30 min.															
2	Standard atmospheric	No.1→No.2															
3	$85 \pm 2^\circ\text{C}$ (Thermostat No.2)	30 min.															
4	Standard atmospheric	No.2→No.1															
Moisture storage	$\Delta L/Lo \leq \pm 5\%$ There shall be no mechanical damage.	The sample shall be left for 96 ± 4 hours in a temperature of $40 \pm 2^\circ\text{C}$ and a humidity(RH) of 90~95%. Upon completion of the test, the measurement shall be made after the sample has been left in a normal temperature and normal humidity more than 1 hour.															
Test conditions : The sample shall be reflow soldered onto the printed circuit board in every test.																	



(5) LAND DIMENSION (Ref.)

PCB: GLASS EPOXY $t=1.6\text{mm}$

(5)-1 LAND PATTERN DIMENSIONS

(STANDARD PATTERN)

unit : mm

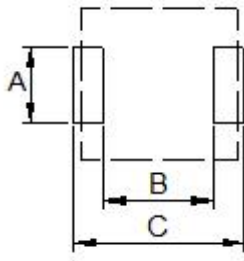

A	B	C
4.1	5.4	13.5

(5)-2 SUBSTRATE BENDING TEST BENDING TEST BOARD

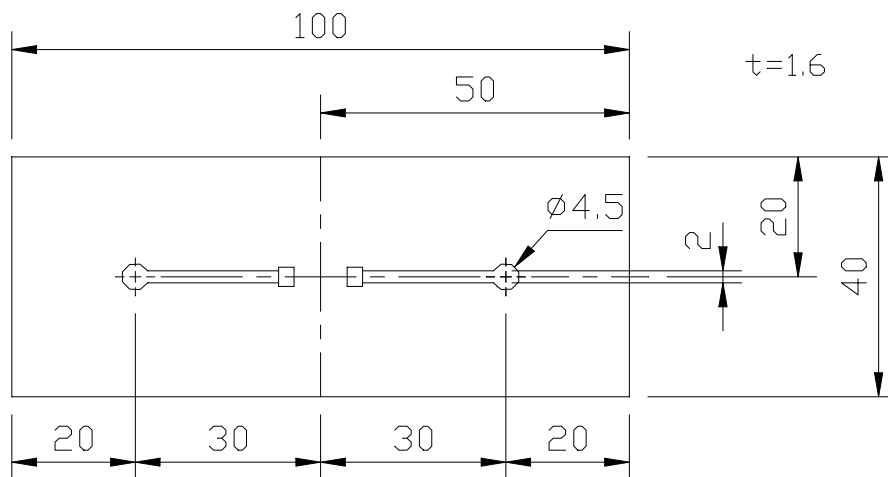

(6) PACKAGING

(6)-1 CARRIER TAPE DIMENSIONS (mm)

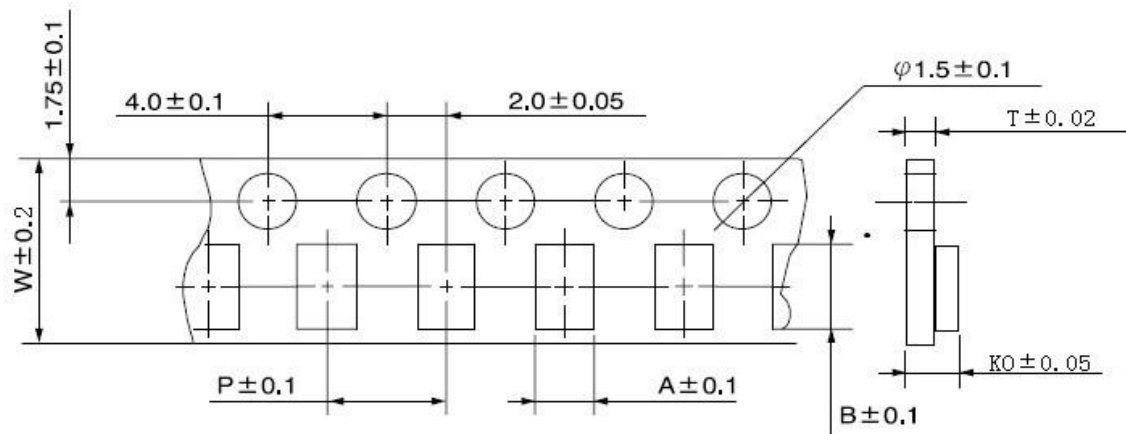

(6)-2 TAPING DIMENSIONS (mm)

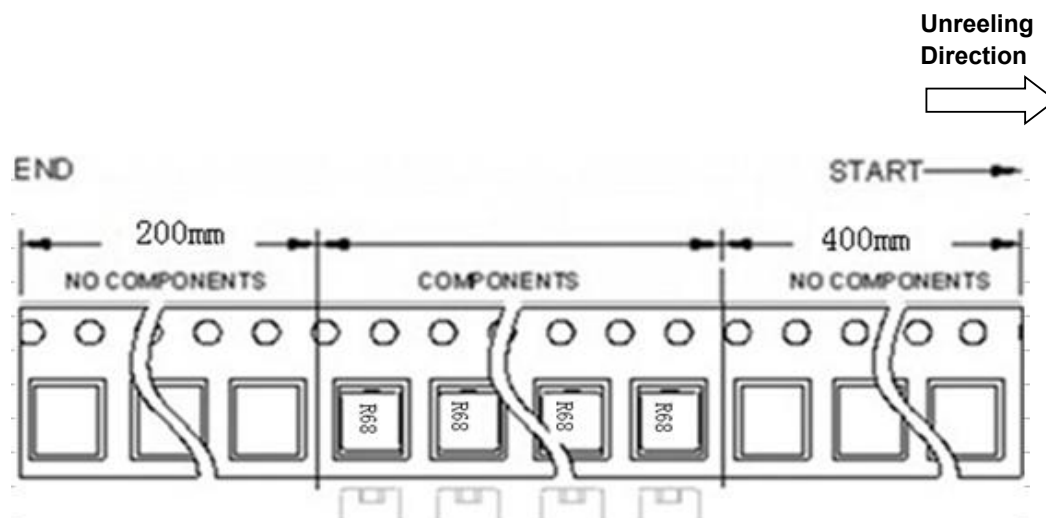

(6)-3 REEL DIMENSIONS (mm)

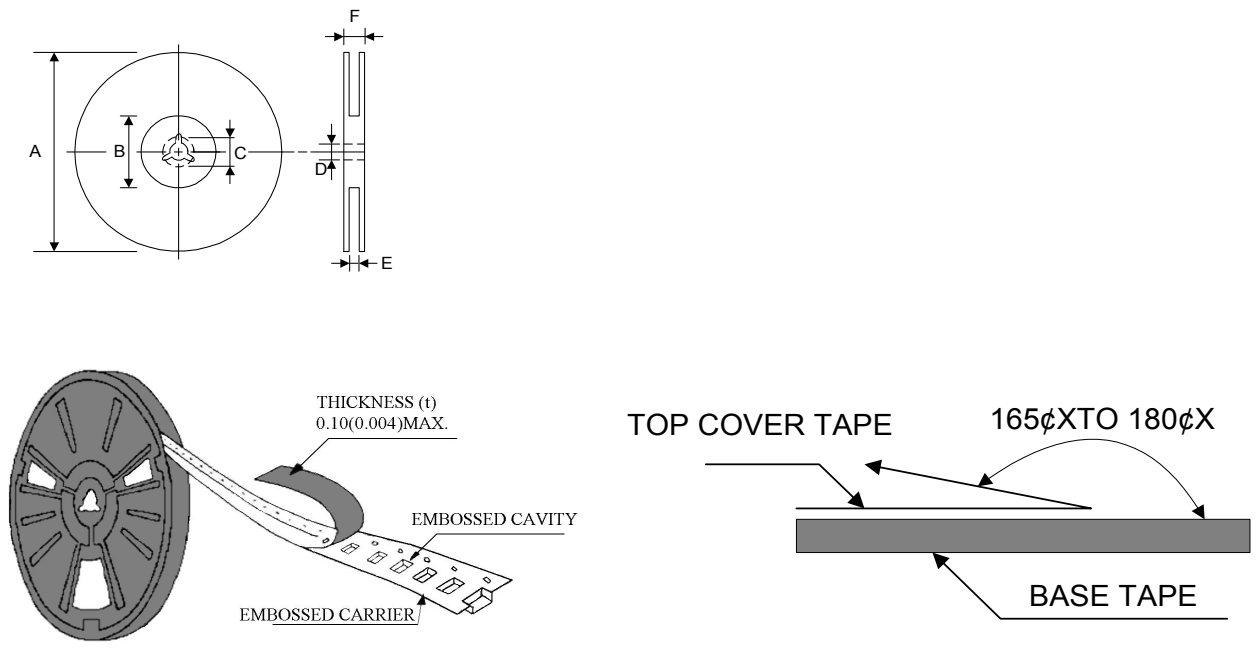

(6)-4 QUANTITY

500 pcs/Reel

The products are packaged so that no damage will be sustained.



X-ON Electronics

Largest Supplier of Electrical and Electronic Components

Click to view similar products for [Fixed Inductors](#) category:

Click to view products by [MAGLAYERS](#) manufacturer:

Other Similar products are found below :

[CR32NP-151KC](#) [CR32NP-180KC](#) [CR32NP-181KC](#) [CR32NP-1R5MC](#) [CR32NP-390KC](#) [CR32NP-3R9MC](#) [CR32NP-680KC](#) [CR32NP-820KC](#) [CR32NP-8R2MC](#) [CR43NP-390KC](#) [CR43NP-560KC](#) [CR43NP-680KC](#) [CR54NP-181KC](#) [CR54NP-470LC](#) [CR54NP-820KC](#) [CR54NP-8R5MC](#) [70F224AI](#) [MGDQ4-00004-P](#) [MHL1ECTTP18NJ](#) [MHQ1005P10NJ](#) [MHQ1005P1N0S](#) [MHQ1005P2N4S](#) [MHQ1005P3N6S](#) [MHQ1005P5N1S](#) [MHQ1005P8N2J](#) [PE-51506NL](#) [PE-53601NL](#) [PE-53602NL](#) [PE-53630NL](#) [PE-53824SNLT](#) [PE-92100NL](#) [PG0434.801NLT](#) [PG0936.113NLT](#) [9220-20](#) [9310-16](#) [PM06-2N7](#) [PM06-39NJ](#) [A01TK](#) [1206CS-471XJ](#) [HC2LP-R47-R](#) [HC2-R47-R](#) [HC3-2R2-R](#) [HCF1305-3R3-R](#) [1206CS-151XG](#) [RCH664NP-140L](#) [RCH664NP-4R7M](#) [RCH8011NP-221L](#) [RCP1317NP-332L](#) [RCP1317NP-391L](#) [RCR1010NP-470M](#)