

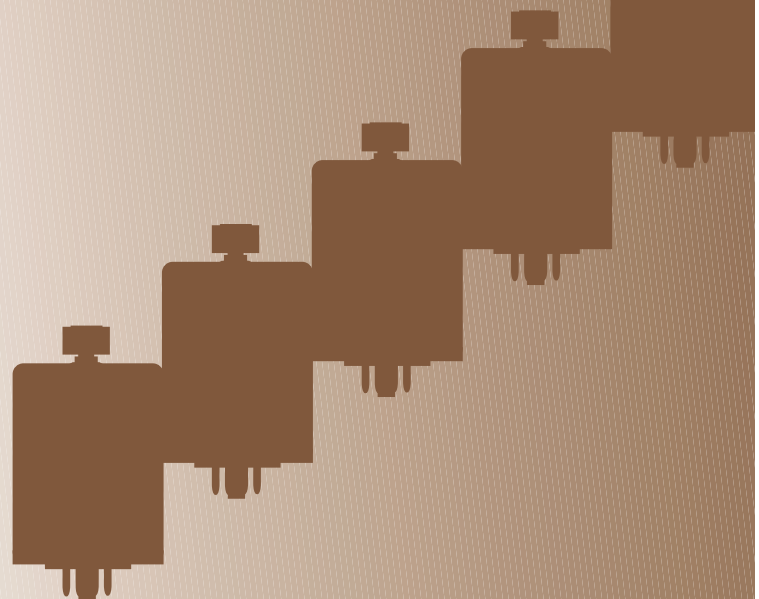

Magnecraft & Struthers-Dunn
Your Contact for Relays

SECTION 4

TIME DELAY RELAYS
5 TO 13 AMPERES

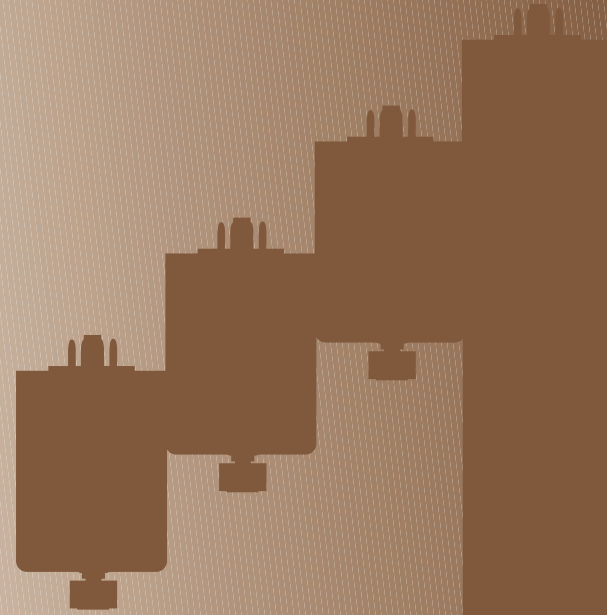

RELAY SERIES

211



L W H
1.7.5 x 2.37 x 3.5

TDRPRO

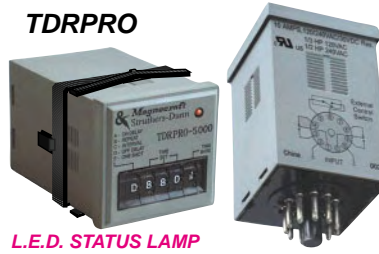

L.E.D. STATUS LAMP

L W H
1.87 x 1.87 x 2.86

67



L W H
1.37 x 0.734 x 1.18

FEATURES

- 8 OR 11 PIN OCTAL PLUG-IN
- ON DELAY, OFF DELAY, INTERVAL AND ONE SHOT MODES AVAILABLE
- REPEATABILITY ±0.1%
- FIELD ADJUSTABLE BY KNOB, OR FIXED TIME AVAILABLE WITHOUT KNOB
- OTHER TIMING RANGES & INPUT VOLTAGES AVAILABLE

- 8 OR 11 PIN OCTAL PLUG-IN
- ON DELAY, REPEAT, INTERVAL, OFF DELAY & ONE SHOT
- UNIVERSAL POWER SUPPLY
- REPEATABILITY ±0.1%
- FIELD ADJUSTABLE BY THUMB WHEELS
- PANEL MOUNTABLE

- MINIATURE PLUG-IN
- ON DELAY
- REPEATABILITY ± 2%
- RECESSED SCREW ADJUSTMENT
- 4 POLE STYLES AVAILABLE
- PRINTED CIRCUIT TERMINALS AVAILABLE
- OTHER TIMING RANGES & INPUT VOLTAGES AVAILABLE

CONTACT DATA

CONTACT CONFIGURATION:

DPDT

SPDT, DPDT

DPDT

CONTACT MATERIAL:

SILVER CADMIUM OXIDE,

SILVER CADMIUM OXIDE
GOLD FLASHED

SILVER GOLD OVERLAY,

CONTACT RESISTANCE:

50 MILLIOHMS MAX. INITIAL

50 MILLIOHMS MAX. INITIAL

50 MILLIOHMS MAX. INITIAL

MAX. CONTACT RATING:

10 AMPS @ 120 / 240 VAC, 30 VDC
1/3 HP @ 240 VAC
1/2 HP @ 120 VAC
NEMA B300 PILOT DUTY

12 AMPS @ 120 / 240 VAC, 30 VDC
RESISTIVE.
1/3 HP @ 120 VAC 1/2 HP @ 240 VAC

5 AMPS @ 120 VAC, 28 VDC

COIL DATA

STANDARD VOLTAGE

AC:
DC:

120 VAC
24 VDC

24 TO 240 VAC
24 TO 240 VDC

120 VAC
12 & 24 VDC

INPUT VOLTAGE RANGE:

85 % TO +110 % (AC)
80 % TO +110 % (DC)
OF NOMINAL

85 % TO +110 % (AC),
80 % TO +110 % (DC)
OF NOMINAL

REVERSE POLARITY PROTECTION:

YES - DC

NON POLARITY SENSITIVE

YES - DC

GENERAL DATA

AMBIENT TEMPERATURE

OPERATING:
STORAGE:

- 30°C TO +55°C
- 55°C TO +85°C

- 10°C TO +55°C
- 40°C TO +85°C

- 30°C TO +55°C
- 50°C TO +85°C

STANDARD TIMING RANGE:

0.1 SECOND TO 120 MINUTES

0.1 SECOND TO 9,990 HOURS

0.1 SECOND TO 450 SECONDS

DIELECTRIC STRENGTH:

1500 V RMS

1500 V rms

1250 V rms

LIFE EXPECTANCY (MIN.)

ELECTRICAL:
MECHANICAL:

200,000 OPERATIONS
10,000,000 OPERATIONS

200,000 OPERATIONS
10,000,000 OPERATIONS

50,000 OPERATIONS
10,000,000 OPERATIONS

AGENCY APPROVALS



PAGE NUMBER

4...1

PAGE 7 - 8

PAGE 9 - 10

PAGE 11

CALL FACTORY FOR OTHER VOLTAGES, TIME AND FUNCTIONS

222



388 EXTERNAL ADJUSTMENT

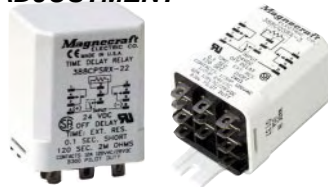

388 KNOB ADJUSTMENT



388 TRUE OFF DELAY



L W H
1.75 x 2.37 x 3.5

L W H
1.40 x 1.53 x 1.90

L W H
1.53 x 1.40 x 3.52

L W H
1.53 x 1.40 x 3.52

- 8 PIN OCTAL PLUG-IN
- REPEAT CYCLE TIMER
- ON AND OFF TIMES INDEPENDENTLY ADJUSTABLE
- REPEATABILITY ±0.1%
- FIELD ADJUSTABLE TIMING USING KNOBS
- OTHER TIMING RANGES & INPUT VOLTAGES AVAILABLE

- SQUARE BASE PLUG-IN OR FLANGE MOUNT
- ON DELAY, OFF DELAY
- REPEATABILITY ±3%
- FIELD ADJUSTABLE TIMING USING EXTERNAL RESISTOR

- SQUARE BASE PLUG-IN
- ON DELAY, OFF DELAY
- REPEATABILITY ±0.1%
- FIELD ADJUSTABLE TIMING USING KNOB

- SQUARE BASE PLUG-IN
- TRUE OFF DELAY
- REPEATABILITY ±3%
- FIELD ADJUSTABLE TIMING USING KNOB
- POWER TO INPUT NOT REQUIRED DURING TIMING CYCLE

DPDT

DPDT

DPDT

DPDT

SILVER CADMIUM OXIDE,
50 MILLIOHMS MAX. INITIAL

SILVER CADMIUM OXIDE,
50 MILLIOHMS MAX. INITIAL

SILVER CADMIUM OXIDE,
50 MILLIOHMS MAX. INITIAL

SILVER CADMIUM OXIDE,
50 MILLIOHMS MAX. INITIAL

10 AMPS @ 120 / 240VAC, 30 VDC
1/3 HP @ 120 VAC,
1/2 HP @ 240 VAC,
NEMA B300 PILOT DUTY

12 AMPS @ 120 VAC, 28 VDC
1/3 HP @ 120 VAC,
1/2 HP @ 240 VAC,
NEMA B300 PILOT DUTY

12 AMPS @ 120 VAC, 28 VDC
1/3 HP @ 120 VAC,
1/2 HP @ 240 VAC,
NEMA B300 PILOT DUTY

12 AMPS @ 120 VAC, 28 VDC
1/3 HP @ 120 VAC,
1/2 HP @ 240 VAC,
NEMA B300 PILOT DUTY

120 VAC

120 VAC
24 VDC

120 VAC
24 VDC

120 VAC
24 VDC

85 % TO +110% (AC),
80 % TO +110% (DC)
OF NOMINAL

85 % TO +110 % (AC)
80 % TO +110 % (DC)
OF NOMINAL

85 % TO +110 % (AC)
80 % TO +110 % (DC)
OF NOMINAL

85 % TO +110 % (AC)
80 % TO +110 % (DC)
OF NOMINAL

YES - DC

YES - DC

YES - DC

YES - DC

- 30°C TO +55°C
- 55°C TO +85°C

- 30°C TO +55°C
- 55°C TO +85°C

- 30°C TO +55°C
- 55°C TO +85°C

- 30°C TO +55°C
- 55°C TO +85°C

0.1 SECOND TO 30 MINUTES

0.1 SECOND TO 120 SECONDS

0.1 SECOND TO 180 SECONDS

0.1 SECOND TO 200 SECONDS

1500 V rms

1500 V rms

2000 V rms

2000 V rms

200,000 OPERATIONS
10,000,000 OPERATIONS

100,000 OPERATIONS
5,000,000 OPERATIONS

100,000 OPERATIONS
5,000,000 OPERATIONS

100,000 OPERATIONS
5,000,000 OPERATIONS



RELAY SERIES

235
CURRENT
SENSOR

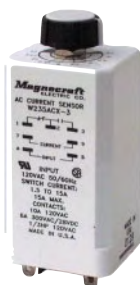

286 & 287



326 & 327



FEATURES

- SQUARE BASE PLUG-IN
- 1.5 TO 15 AMP SENSING RANGE
- ±2% REPEATABILITY
- SPDT CONTACT CONFIGURATION
- FIELD ADJUSTABLE WITH KNOB

- SQUARE BASE PLUG-IN
- 286-ON DELAY, 287-OFF DELAY
- REPEATABILITY ±3%
- TIMING FIELD ADJUSTABLE BY KNOB OR EXTERNAL RESISTOR
- FIXED VERSIONS AVAILABLE
- 10 AMPS SWITCHING
- UP TO 3 POLES

- 8 or 11 PIN OCTAL PLUG-IN
- 326 ON DELAY, 327 OFF DELAY
- ± 3% REPEATABILITY
- TIMING FIELD ADJUSTABLE BY KNOB OR EXTERNAL RESISTOR
- FIXED VERSIONS AVAILABLE
- 10 AMP SWITCHING
- UP TO 3 POLES

CONTACT DATA

CONTACT CONFIGURATION:

SPDT

SPDT, DPDT, 3PDT

SPDT, DPDT, 3PDT

CONTACT MATERIAL:

SILVER CADMIUM OXIDE,

SILVER CADMIUM OXIDE,

SILVER CADMIUM OXIDE,

CONTACT RESISTANCE:

50 MILLIOHMS MAX. INITIAL

50 MILLIOHMS MAX. INITIAL

50 MILLIOHMS MAX. INITIAL

MAX. CONTACT RATING:

10 AMPS @ 120 VAC
6 AMPS 28 VDC

10 AMPS @ 120/240 VAC, 28 VDC
1/3 HP @ 120 VAC,
1/2 HP @ 240 VAC,

10 AMPS @ 120/240 VAC, 30 VDC
1/3 HP @ 120 VAC,
1/2 HP @ 240 VAC,

COIL DATA

STANDARD VOLTAGE

AC:

DC:

120 VAC

24 TO 240 VAC
12 TO 125 VDC

24 TO 240 VAC
12 TO 125 VDC

INPUT VOLTAGE RANGE:

85 % TO 110 % OF NOMINAL

85 % TO +110 % (AC),
80 % TO +110 % (DC)
OF NOMINAL

85 % TO +110 % (AC)
80 % TO +110 % (DC)
OF NOMINAL

REVERSE POLARITY
PROTECTION:

NOT APPLICABLE

YES - DC

YES - DC

GENERAL DATA

AMBIENT TEMPERATURE

OPERATING:

STORAGE:

- 30°C TO +55°C
- 40°C TO +85°C

- 10°C TO +70°C
- 55°C TO +85°C

- 10°C TO +70°C
- 55°C TO +85°C

STANDARD TIMING RANGE:

1.5 TO 15 AMPS

0.1 SECOND TO 300 SECONDS

0.1 SECOND TO 300 SECONDS

DIELECTRIC STRENGTH:

2500 V rms

1500 V rms

1500 V rms

LIFE EXPECTANCY

ELECTRICAL:

MECHANICAL:

200,000 OPERATIONS
5,000,000 OPERATIONS

100,000 OPERATIONS
10,000,000 OPERATIONS

100,000 OPERATIONS
10,000,000 OPERATIONS

AGENCY APPROVALS



UL Recognized
File No. E62636



UL Recognized
File No. E13224



UL Recognized
File No. E13224

PAGE NUMBER

4...3

PAGE 18

PAGE 19 - 20

PAGE 21 - 22

246 & 247



236
VOLTAGE SENSOR

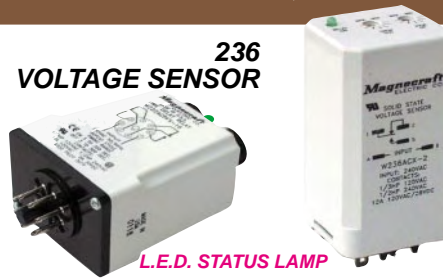

L W H
2.62 X 1.46 x 4.06

L W H
SEE PAGE 26

- 12 OR 14 PIN PLUG-IN. WITH INTEGRAL LOCKING CLIP
- RUGGED INDUSTRIAL DESIGN
- STYLE 246 - ON DELAY, STYLE 247 - OFF DELAY
- ±3% REPEATABILITY
- 2 - 4 POLE CONTACT CONFIGURATIONS
- LARGE CHOICE OF OPTIONS

- SQUARE BASE OR OCTAL PLUG-IN
- INDEPENDENTLY ADJUSTABLE PICK AND DROP OUT VOLTAGES
- TIME DELAYED ACTION AVAILABLE
- ±1% REPEATABILITY
- LED POWER INDICATOR
- FIELD ADJUSTABLE RECESSED POTS OR KNOBS

SEE CATALOG PAGE

SPDT, DPDT

SILVER CADMIUM OXIDE,
GOLD DIFFUSED
50 MILLIOHMS MAX. INITIAL

SILVER CADMIUM OXIDE,
50 MILLIOHMS MAX. INITIAL

10 AMPS @ 120/240 VAC, 28 VDC

SPST:13 AMPS @ 120/240 VAC, 28 VDC
1/3 HP @ 120 VAC, 1/2 HP @ 240 / 480 VAC
3 AMPS @ 480 VAC.NEMA B300 PILOT DUTY
DPDT:10 AMPS @ 120 / 240 VAC, 28 VDC
1/3 HP @ 120 VAC, 1/2 HP @ 240 VAC
NEMA B300 PILOT DUTY

24 TO 240 VAC
12 TO 250 VDC

24 TO 480 VAC
24 VDC

85 % TO +110 % (AC),
80 % TO +110 % (DC)
OF NOMINAL

YES - DC

YES - DC

- 10°C to +55°C
- 55°C to +70°C

- 30°C to +55°C
- 40°C to +85°C

0.1 SECOND TO 300 SECONDS

SEE CATALOG PAGE

1500 V rms

2500 V rms

100,000 OPERATIONS
10,000,000 OPERATIONS

100,000 OPERATIONS
10,000,000 OPERATIONS (DPDT)



246 SERIES



UL Recognized
File No. E62636

Magnecraft & Struthers-Dunn

Your Contact for Relays

U. S. A.

TELEPHONE: (843) 393-5778

FAX: (843) 393-4123

WEBSITE: www.magnecraft.com

EMAIL: info@magnecraft.com

EUROPE

TELEPHONE: 4989 / 75080310

FAX: 4989 / 7559344

WEBSITE: www.magnecraft.com

EMAIL: renatesteinback@magnecraft.de

APPLICATION DATA

WHAT IS A TIME DELAY RELAY:

A Time Delay relay is a combination of an electromechanical output relay and a control circuit. The control circuit is comprised of solid state components and timing circuits that control operation of the relay and timing range. Typical time delay functions include On-Delay, Off-Delay, Repeat cycle, One Shot, Interval, On-Delay & Off Delay (Combination) and True Off Delay. Each function is explained below. Time delay relays have a broad choice of timing ranges from less than one second to hours. There is a choice of timing adjustments from calibrated external knob, recessed pots or internally fixed timing. The output contacts on the electromechanical output relay are direct wired to the output terminals. The contact load ratings are specified for each specific type of time delay relay.

TIMING FUNCTIONS:

ON-DELAY- (SLOW OPERATE RELAY)

Upon application of power to the input, the time delay period begins. At the end of the time delay period, output contacts transfer. Input power must be removed to return output contacts to home position and reset the control circuit. If input power is interrupted before a timing period ends, timing stops. When input power is restored, timing starts from the beginning.

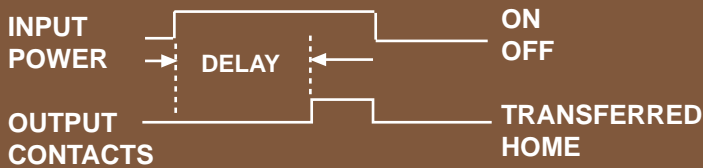

Some typical Applications: Cascade starting, Air Conditioning & heating controls, Burglar Alarms, Power Outage delay, instrument Control.

OFF-DELAY (SLOW RELEASE RELAY)

Continuous power must be applied to input during all timing sequences. Upon closure of external control switch, output contacts transfer. Upon opening control switch, the timing period begins. When timing period ends, output contacts return home. To repeat this timing cycle, the control switch must be re-closed and then opened. If input power is interrupted during timing cycle, the output contacts return to home position and the control switch must be closed and reopened to start the timing from the beginning. If the control switch closes during a timing period, timing stops and output contacts remain transferred. When control switch is opened, timing will start again from the beginning. The timing period can be extended, repeatedly using the control switch in this way until the last initiated timing period is permitted to end and output contacts return home.

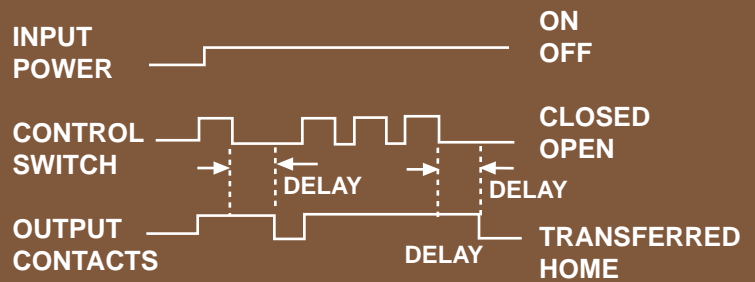

Some typical Applications: Air Conditioning, automatic Door Controls, Lighting Controls, burglar alarms, Vending Machines, circuits, conveyor systems, instrument control, watchdog circuits.

REPEAT CYCLE (FLASHER)

Upon application of power to the input, the Off time delay Period begins. The contacts transfer at the end of the Off time Delay Period and the ON time delay period begins. At the end of the ON time delay period output contacts return home and OFF time delay period begins again. This sequence will continue as long as input power is supplied to the Input Pins.

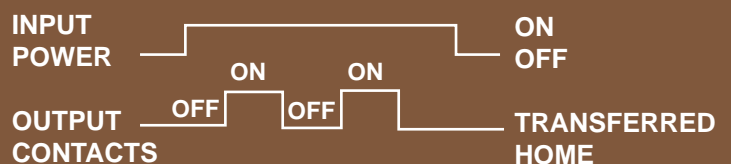

Some typical Applications: Signs, Product testing, signal devices, machine control, Signal warning devices, conveyor control.



ONE SHOT (RETRIGGERABLE)

Continuous power must be applied to the input during all timing sequences. Upon closure of external control switch, output contacts transfer and timing period begins. When timing period ends, output contacts return home. Once the timing period begins, the control switch may remain closed or opened without affecting timing. To repeat this cycle, the control switch must be open, or opened at the end of the timing period, and then closed to start timing period over again.

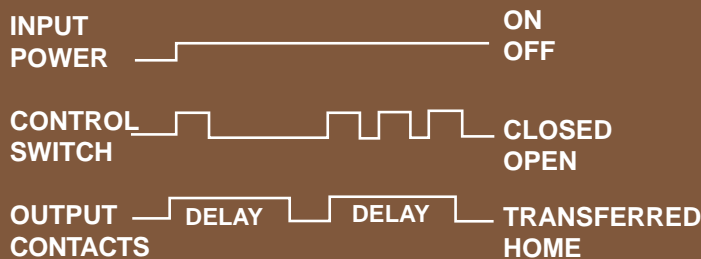

Some typical Applications: Vending machines, dispensing controls, machine control, welding control,

INTERVAL

Upon application of power to the input, the output contacts transfer and the delay period begins. At the end of the time delay period, the output contacts return home. Input power must be interrupted to recycle timer.



Some typical Applications: Machine control, End of process alarm, Welding control, Photographic timing.

ON-DELAY & OFF-DELAY- (COMBINATION)

Continuous power must be applied to the input during all timing sequences. Upon closure of the external control switch, first time delay period T1 begins. When T1 period ends, output contacts transfer. Then, when control switch is opened, second delay period T2 begins. When T2 ends, output contacts return home. To repeat this timing cycle, repeat this sequence from the beginning. If the prevailing open or closed status of the control switch is changed during either T1 or T2 Timing periods, timing stops. Position of output contacts remain as they were. Returning control switch to its pre-changed position restarts interrupted timing period from the beginning and normal timing resumes.

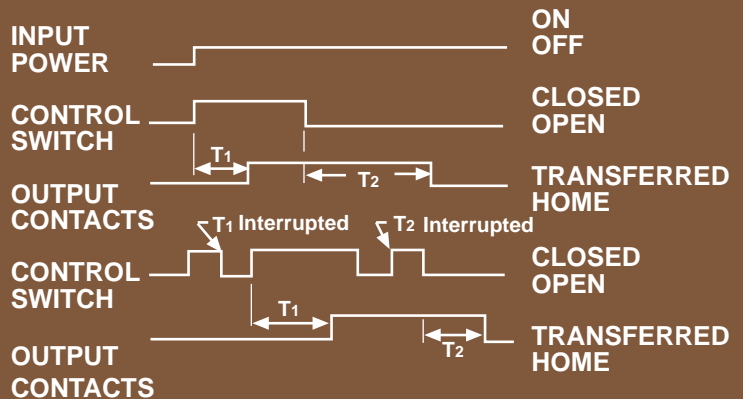

Some typical Applications: Cascade starting & stopping of heavy loads, laboratory equipment, machine control

TRUE OFF DELAY- (SLOW RELEASE)

Upon application of power to the input, output contacts transfer. The delay period begins when power is removed from the input. If power is supplied to input during the timing period, time is reset and time delay period starts over again when power is removed from the input.

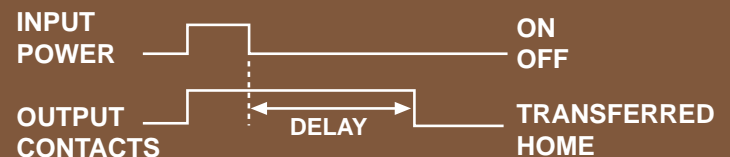

Some typical Applications: Loss of power alarm control, Burglar alarms.



U. S. A.
 TELEPHONE: (843)393-5778
 FAX: (843)393-4123
 WEBSITE: www.magnecraft.com
 EMAIL: info@magnecraft.com

EUROPE
 TELEPHONE: 4989 / 75080310
 FAX: 4989/ 7559344
 WEBSITE: www.magnecraft.com
 EMAIL: renatesteinback@magnecraft.de

DPDT, 10 AMPS

**THE CLASS 211 TIME DELAY RELAY
MAKES USE OF HYBRID CIRCUITRY,
COMBINING INTEGRATED CIRCUITS
FOR A MULTITUDE OF TIMING FUNCTIONS,
AND THE RELIABILITY OF RELAY TECHNOLOGY.**

cUL us
UL Recognized
File No. E43641



UL LISTED
367G

WHEN USED
WITH SOCKETS
70-464-1 (8 PIN)
70-465-1 (11 PIN)



COMPLIES WITH REQUIREMENTS OF

- * IEC STANDARDS 947-4-1 AND 947-5-1 LOW VOLTAGE DIRECTIVE
- * IEC = INTERNATIONAL ELECTROTECHNICAL COMMISSION
- * CE TESTING AND EVALUATION PERFORMED BY THE UNDERWRITERS LABORATORIES AS A THIRD PARTY PARTICIPANT

GENERAL SPECIFICATIONS

TIMING

Operating Modes Available:	On delay, off delay, Interval, one shot
Timing Adjustments Available:	0.1 to 120 minutes
Repeatability (Repeat Accuracy when Stabilized):	±0.1% max. or ±33 mS AC min. or ± 10 mS DC. min. @ constant voltage & temperature
Timing Change Over Temperature and Voltage Range:	± 10%
Timing Tolerance High End:	- 0 to + 40%
Timing Tolerance Low End :	+ 0 to - 40%
Reset Time:	100 milliseconds max.

CONTACTS

Contact Rating:	10 amps @ 120VAC / 30VDC resistive load, 1/2 Hp @ 240 VAC, 1/3 Hp @ 120 VAC, NEMA B300 pilot duty
Contact Life:	200,000 operations @ 120VAC, 10 amps resistive load 1,000,000 operations @ 120 VAC, 5 amps resistive load 2,000,000 operations @ 120VAC, 2 amps resistive load
Mechanical Life:	10,000,000 operations

INPUT

Operating Voltage Range:	AC: 85 % to 110 %, DC: 80 % to 110 % of nominal
Temperature range (Operate):	- 30 °C to + 55°C
Temperature range (Storage):	- 55°C to + 85°C
Steady State Input Current:	80 mA @ 24 VAC, 20 mA @ 120 VAC, 15 mA @ 230 VAC, 80 mA @ 12 VDC, 50 mA @ 28 VDC, 30 mA @ 48 VDC

PROTECTION

Reverse Polarity:	Yes - DC
Transient:	UL 508 surge test: 5000V for 50 uS
Noise Immunity:	NEMA ICS2-230 2500 VAC

DIELECTRIC STRENGTH

Coil to Contacts:	1500 V rms
Across Open Contacts:	1000 V rms

MECHANICAL

Operating Position:	Any
Enclosure:	Polycarbonate dust cover
Mounting:	Standard 8 or 11 pin octal
Weight:	115 grams approx



Mating Sockets
70-750D8-1, 70-750D11-1,
70-464-1, 70-465-1: SCREW/DIN
70-169-1, 70-170-1: SCREW/PANEL
See section 8, page 7 - 12

DPDT, 10 AMPS

OUTLINE DIMENSIONS
DIMENSIONS SHOWN IN INCHES & (MILLIMETERS).

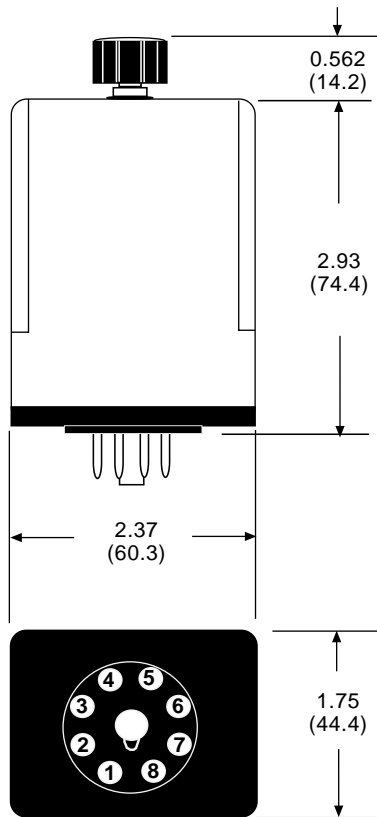

8 PIN OCTAL

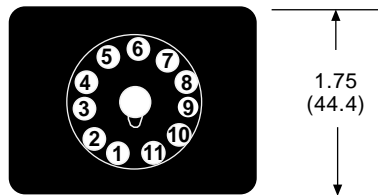

11 PIN OCTAL

ON-DELAY

OFF-DELAY



WIRING DIAGRAMS

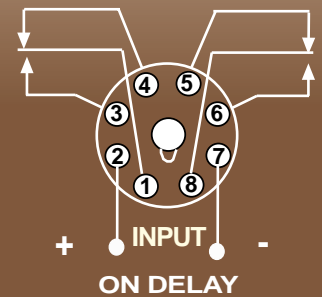

EXTERNAL CONTROL SWITCH

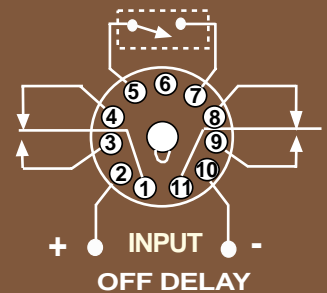

EXTERNAL SWITCH SHALL NOT BE CONNECTED TO ANY EXTERNAL LOAD OR VOLTAGE. DAMAGE TO INTERNAL COMPONENTS CAN OCCUR.

STANDARD PART NUMBERS	NOMINAL INPUT VOLTAGE	TIMING RANGE
-----------------------	-----------------------	--------------

ON DELAY

W211ACPSOX-18	120 VAC	0.1 TO 1.0 SECONDS
W211ACPSOX-5	120 VAC	0.1 TO 10 SECONDS
W211ACPSOX-7	120 VAC	1.0 TO 180 SECONDS
W211ACPSOX-8	120 VAC	2.0 TO 300 SECONDS
W211ACPSOX-60	120 VAC	1.0 TO 15 MINUTES
W211ACPSOX-61	120 VAC	2.0 TO 30 MINUTES
W211ACPSOX-62	120 VAC	4.0 TO 60 MINUTES
W211ACPSOX-63	120 VAC	8.0 TO 120 MINUTES
W211CPSOX-1	24 VDC	0.1 TO 10 SECONDS
W211CPSOX-3	24 VDC	1.0 TO 180 SECONDS

OFF DELAY

W211ACPSRX-5	120 VAC	0.1 TO 10 SECONDS
W211ACPSRX-7	120 VAC	1.0 TO 180 SECONDS
W211ACPSRX-8	120 VAC	2.0 TO 300 SECONDS
W211ACPSRX-60	120 VAC	1.0 TO 15 MINUTES
W211CPSRX-1	24 VDC	0.1 TO 10 SECONDS
W211CPSRX-3	24 VDC	1.0 TO 180 SECONDS

CALL FACTORY FOR OTHER VOLTAGES, TIME AND FUNCTIONS



SPDT & DPDT, 12 AMPS

FEATURES

5 TIMING FUNCTIONS, TIMING RANGES FROM 0.1 SECONDS TO 9,990 HOURS, UNIVERSAL VOLTAGE INPUT AND 12 AMP OUTPUT FOR HIGHER POWER APPLICATIONS

UNIVERSAL POWER SUPPLY ALLOWS FOR INPUT VOLTAGES FROM 24 TO 240 VDC OR VAC 50/60HZ.

CLASS "F" INSULATION SYSTEM

THUMB WHEEL ADJUSTMENTS FOR FUNCTION AND TIMING

RED L.E.D. LAMP INDICATOR

0.1 % ACCURACY USING A CRYSTAL CLOCK

MOUNTING CLIP ALLOWS FOR VARIED PANEL THICKNESSES,

BENEFITS

FIVE FUNCTIONS - ONE PACKAGE

ONE PART FOR MOST VOLTAGES

12 AMPS CONTACT RATING

POSITIVE POSITION THUMB WHEEL ADJUSTMENT

STATUS L.E.D.

ACCURATE TIME, ALL THE TIME

PANEL CLIP INCLUDED

UL
UL Recognized
File No. E43641

CE PENDING

COMPLIES WITH REQUIREMENTS OF

- * IEC STANDARDS 947-4-1 AND 947-5-1 LOW VOLTAGE DIRECTIVE
- * IEC = INTERNATIONAL ELECTROTECHNICAL COMMISSION
- * CE TESTING AND EVALUATION PERFORMED BY THE UNDERWRITERS LABORATORIES AS A THIRD PARTY PARTICIPANT

MANUFACTURED UNDER ISO 9002 & QS 9000

GENERAL SPECIFICATIONS

TIMING

Operating Modes Available: On delay, repeat, one shot, off delay & interval
 Timing Adjustments: 0.1 second to 9,990 hours
 Repeatability: 0.1%, (Internal crystal)
 (Constant Voltage and Temperature)

CONTACTS

Contact Material: Silver cadmium oxide, gold flashed
 Contact Rating: 12 amps @ 120 / 240 VAC, 30 VDC resistive
 1/3 Hp @ 120 VAC 1/2 Hp @ 240 VAC

INPUT

Voltage Range: 24 to 240 VDC / VAC ± 15%, 50/60 Hz.
 Temperature Range (Operate): -10°C to +55°C
 Temperature Range (Storage): -40°C to +85°C
 Transient Protection: Yes
 Reverse Polarity Protection: Non polarity sensitive

DIELECTRIC STRENGTH

Between Output Poles: 1,500 V rms
 Between Input and Output: 1,500 V rms

LIFE EXPECTANCY

Electrical: 100,000 operations
 Mechanical: 10,000,000 operations

MISCELLANEOUS

Operating Position: Any
 Enclosure: Gray polycarbonate
 Mounting: 11 pin octal plug-in, 8 pin octal
 1.8 x 1.8 (45 x 45) panel cutout
 Weight: 122 grams approx.



Mating Sockets
70-750D8-1, 70-750D11-1,
70-464-1, 70-465-1: SCREW/DIN
70-169-1, 70-170-1: SCREW/PANEL
 See section 8, page 7 - 12

SPDT & DPDT, 12 AMPS

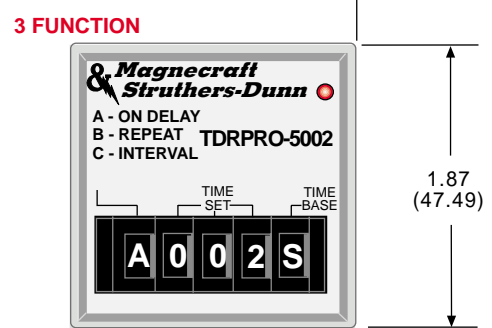
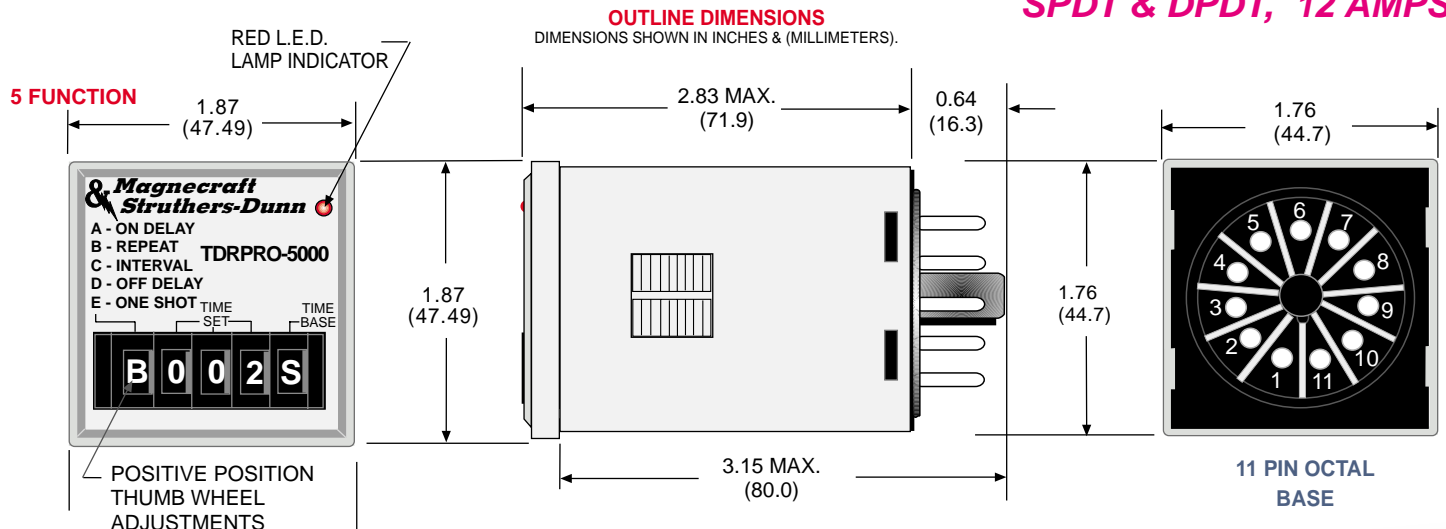

PANEL CUTOUT FOR PANEL MOUNTING

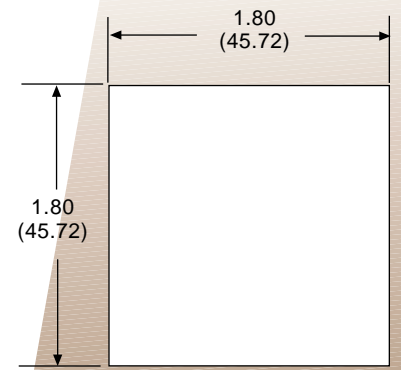

WIRING DIAGRAMS

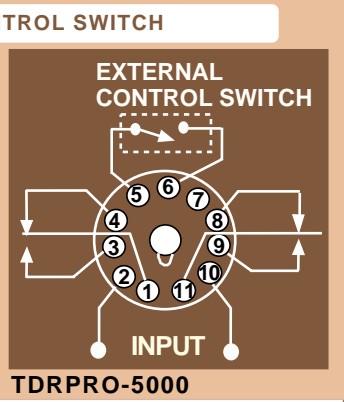
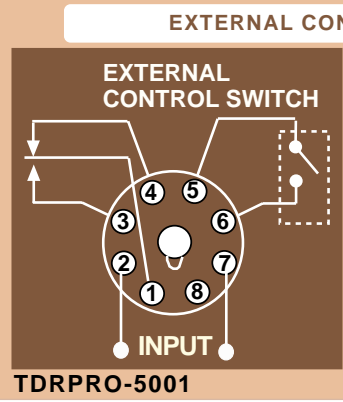
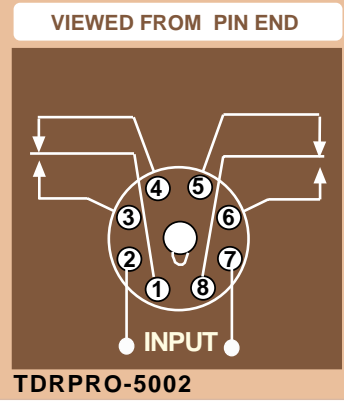

EXTERNAL SWITCH SHALL NOT BE CONNECTED TO ANY EXTERNAL LOAD OR VOLTAGE. DAMAGE TO INTERNAL COMPONENTS CAN OCCUR.



STANDARD PART NUMBERS	NOMINAL INPUT VOLTAGE	TIMING RANGE
5 FUNCTION - 11 PIN		
TDRPRO-5000	24-240 VAC 24-240 VDC	0.1 SECOND TO 9,990 HOURS
5 FUNCTION - 8 PIN		
TDRPRO-5001	24-240 VAC 24-240 VDC	0.1 SECOND TO 9,990 HOURS
3 FUNCTION - 8 PIN		
TDRPRO-5002	24-240 VAC 24-240 VDC	0.1 SECOND TO 9,990 HOURS

DPDT, 5 AMPS

OUTLINE DIMENSIONS

DIMENSIONS SHOWN IN INCHES & (MILLIMETERS).

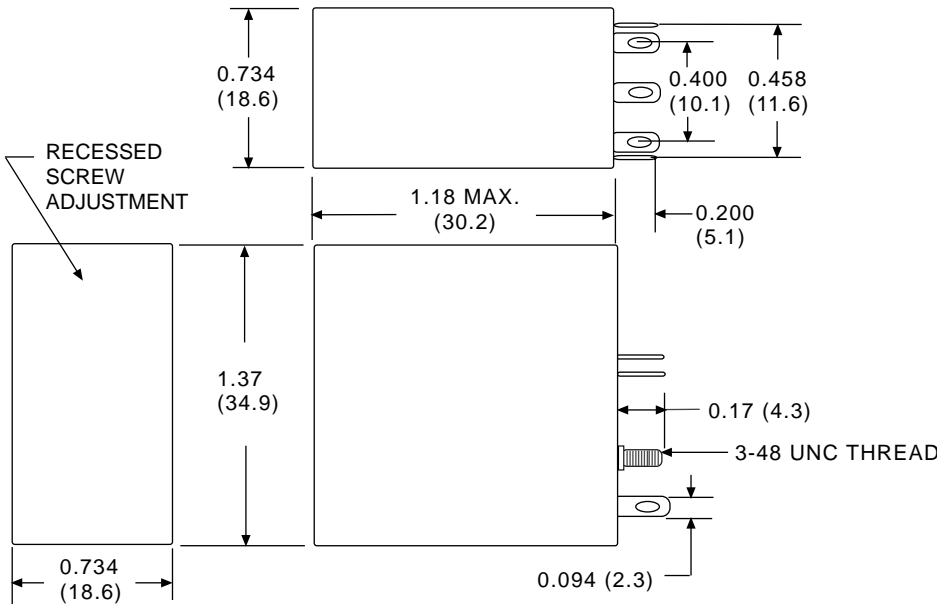

UL Recognized
File No. E43641



CHASSIS CUTOUT FOR PANEL MOUNTING

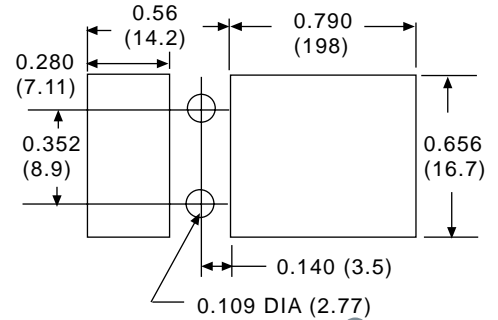

GENERAL SPECIFICATIONS

TIMING

Operating Modes Available: On delay,
Timing Adjustments Available: 0.1 to 450 seconds
Repeatability:
(Repeat Accuracy when Stabilized): ± 2% max. @ nominal voltage @ 25°C
Reset time: 100 milliseconds max.

CONTACTS

Contact Rating: 5 Amps @ 120VAC / 28 VDC resistive
Contact Life: 50,000 operations @ 120 VAC, 5 amps resistive
1,500,000 operations @ 120 VAC, 2 amps resistive load
12,000,000 operations @ 120 VAC, 1 amp resistive load
Mechanical Life: 10,000,000 operations

INPUT

Operating Voltage Range: AC: 85 % to 110 %, DC: 80 % to 110 % of nominal
Temperature Range (Operate): -30°C to + 55°C
Temperature Range (Storage): -50°C to +85°C
Steady State Input Current: 40 mA @ 24 VDC, 80 mA @ 12 VDC

PROTECTION

Reverse Polarity: Yes - DC
Transient: Twice nominal voltage for 1 millisecond

DIELECTRIC STRENGTH

Coil to Contacts: 500 V rms
Across Open Contacts: 1250 V rms

MECHANICAL

Operating Position: Any
Enclosure: Polycarbonate dust cover
Mounting: Socket plug-in/solder also available with printed circuit terminals
Weight: 35.2 grams approx



WIRING DIAGRAM

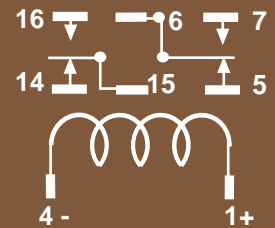

Chassis Mount Socket:

70-307-1

PCB Socket:

70-308-1

See section 8, page 25. 26

STANDARD PART NUMBERS	NOMINAL INPUT VOLTAGE	TIMING RANGE
ON DELAY		
W67CPSOX-1	12 VDC	0.1 TO 30 SECONDS
W67CPSOX-2	24 VDC	0.1 TO 30 SECONDS

DPDT, 5 AMPS

OUTLINE DIMENSIONS

DIMENSIONS SHOWN IN INCHES & (MILLIMETERS).

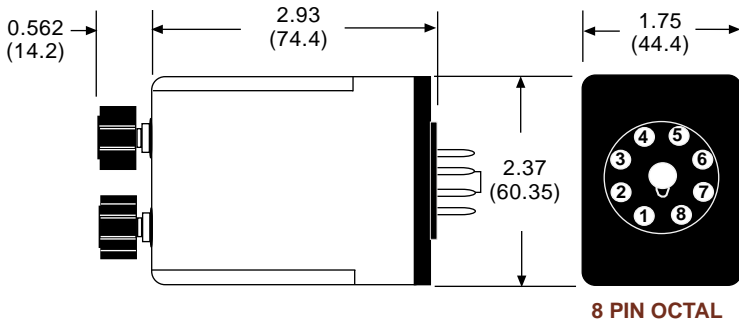

8 PIN OCTAL



UL Recognized
File No. E43641



COMPLIES WITH REQUIREMENTS OF

- * IEC STANDARDS 947-4-1 AND 947-5-1 LOW VOLTAGE DIRECTIVE
- * IEC = INTERNATIONAL ELECTROTECHNICAL COMMISSION
- * CE TESTING AND EVALUATION PERFORMED BY THE UNDERWRITERS LABORATORIES AS A THIRD PARTY PARTICIPANT

INDEPENDENT TIME SETTINGS FOR BOTH "ON" AND "OFF" TIMING RANGES

GENERAL SPECIFICATIONS

TIMING

Operating Modes Available:	Repeat cycle timing
Timing Adjustments Available:	0.1 to 30 minutes
Repeatability (Repeat Accuracy when Stabilized):	±0.1% Max. or ± 33 mS AC min. or ± 10 mS DC. min. @ constant voltage & temperature
Timing change over temperature and voltage range:	± 10%
Timing Tolerance high end of range:	- 0 to + 40%
Timing Tolerance low end of range:	+ 0 to - 40%
Reset time:	100 milliseconds max.

CONTACTS

Contact Rating:	10 Amps @ 120 / 240 VAC, 30 VDC resistive load, 1/2 Hp @ 240 VAC, 1/3 Hp @ 120 VAC, NEMA B300 pilot duty
Contact Life:	200,000 operations @ 120VAC, 10Amp resistive load 1,000,000 operations @ 120 VAC, 5 Amp resistive load 2,000,000 operations @ 120VAC, 2 Amps resistive load
Mechanical Life:	10,000,000 operations

INPUT

Operating Voltage Range:	AC: 85% to 110%, DC: 80% to 110% of nominal
Temperature Range (Operate):	-30°C to +55°C
Temperature Range (Storage):	-55°C to +85°C
Steady State Input Current:	25 mA @ 120 VAC, 25 mA @ 240 VAC, 80 mA @ 12 VDC, 40 mA @ 24 VDC, 24 mA @ 48 VDC.

PROTECTION

Reverse Polarity:	Yes - DC
Transient:	UL 508 saurge test: 5000V for 50 uS
Noise Immunity:	NEMA ICS2-230 2500 VAC

DIELECTRIC STRENGTH

Coil to Contacts:	1500 V rms
Across Open Contacts:	1000 V rms

MECHANICAL

Operating Position:	Any
Enclosure:	Polycarbonate dust cover
Mounting:	8 pin octal
Weight:	132 grams approx.

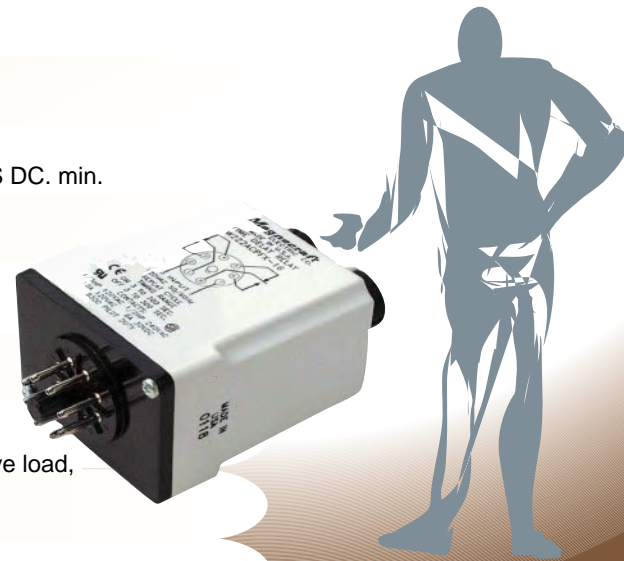

WIRING DIAGRAM

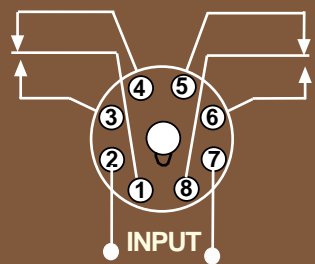

Mating Sockets
70-750D8-1, 70-750D11-1,
70-464-1, 70-465-1: SCREW/DIN
70-169-1, 70-170-1: SCREW/PANEL
See section 8, page 7 - 12

STANDARD PART NUMBERS	NOMINAL INPUT VOLTAGE	TIMING RANGE
REPEAT CYCLE		
W222ACPFX-11	120 VAC	0.1 TO 10 SECONDS
W222ACPFX-16	120 VAC	3 TO 300 SECONDS
W222ACPFX-27	120 VAC	2 TO 30 MINUTES

DPDT, 12 AMPS

"ON" OR "OFF" DELAY FUNCTIONS
EXTERNAL RESISTANCE ADJUSTABLE
± 3 % REPEATABILITY DPDT, 12 AMP



UL Recognized
 File No. E52197



COMPLIES WITH REQUIREMENTS OF

- * IEC STANDARDS 947-4-1 AND 947-5-1 LOW VOLTAGE DIRECTIVE
- * IEC = INTERNATIONAL ELECTROTECHNICAL COMMISSION
- * CE TESTING AND EVALUATION PERFORMED BY THE UNDERWRITERS LABORATORIES AS A THIRD PARTY PARTICIPANT

GENERAL SPECIFICATIONS

TIMING

Operating Modes Available:	On delay, off delay
Timing Adjustments Available:	0.1 to 120 seconds
Repeatability:	±3% @ nominal voltage @ 25°C
Percent Timing Change Over Temperature and Voltage Range:	±10%
Timing Tolerance High End :	-0 to +40%
Timing Tolerance Low End:	+0 to -40%

CONTACTS

Contact Rating:	12 amps @ 120 VAC/28 VDC resistive 1/3 HP, 120 VAC, 1/2 HP, 240 VAC B300 pilot duty.
Contact Life:	100,000 operations @ 120 VAC 12 amps resistive load. 1,000,000 operations @ 28 VDC 5 amps resistive load.
Mechanical Life:	5,000,000 operations

INPUT

Operating Voltage Range:	AC: 85% to 110%, DC: 80% to 110% of nominal
Temperature Range (Operate):	- 30°C to + 55°C
Temperature Range (Storage):	- 55°C to + 85°C
Steady State Input Current:	20 mA @ 120 VAC, 60 mA @ 24 VDC

PROTECTION

Reverse Polarity:	Yes - DC
Transient:	Twice nominal voltage for 1 millisecond

DIELECTRIC STRENGTH

Coil to Contacts:	1500 V rms
Across Open Contacts:	1000 V rms

MECHANICAL

Operating Position:	Any
Enclosure:	Polycarbonate dust cover
Terminals:	0.187 x 0.020" quick connect terminals
Weight:	96 grams approx.

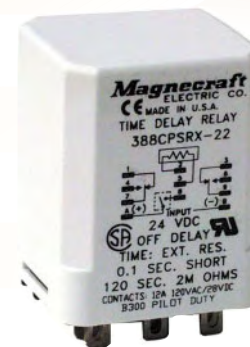

Mating Sockets

70-463-1: SCREW/DIN
70-124-1: SOLDER
70-178-1, 70-178-2: PRINTED CIRCUIT
70-124-2: QUICK CONNECT
 See section 8, page 16, 17

DPDT, 12 AMPS

OUTLINE DIMENSIONS

DIMENSIONS SHOWN IN INCHES & (MILLIMETERS).

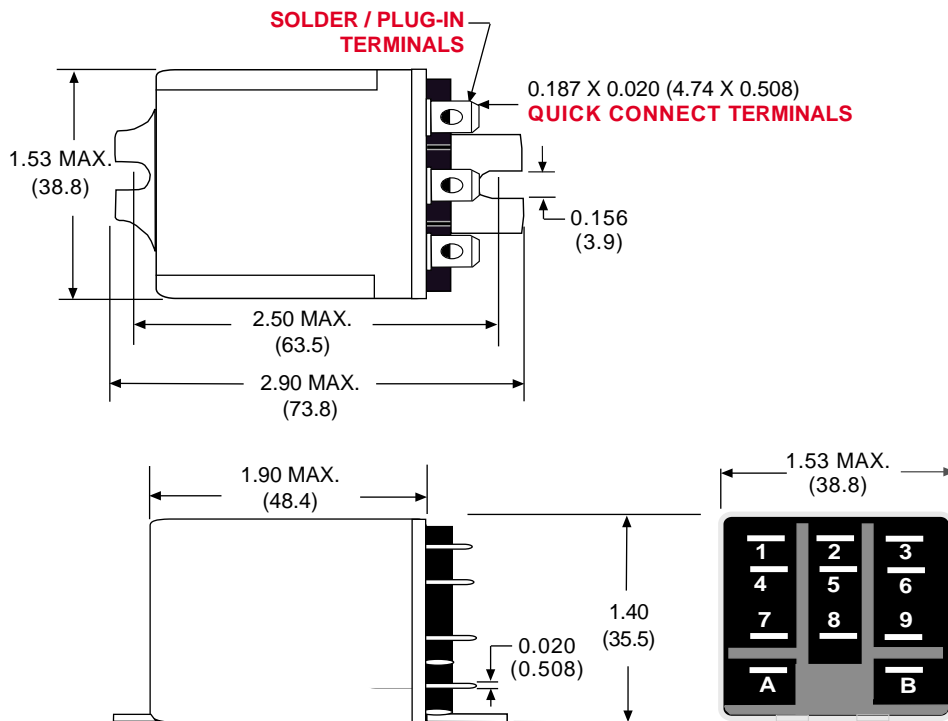

WIRING DIAGRAMS

EXTERNAL RESISTOR

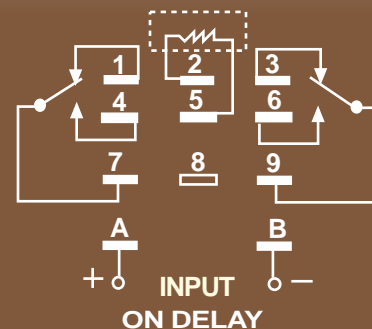

EXTERNAL RESISTOR

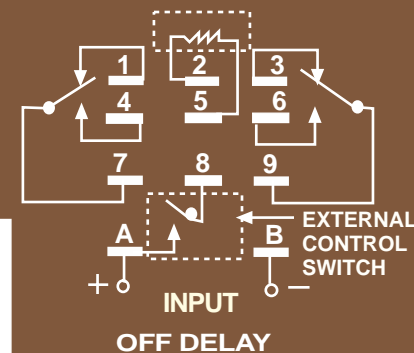

EXTERNAL SWITCH SHALL NOT BE CONNECTED TO ANY EXTERNAL LOAD OR VOLTAGE. DAMAGE TO INTERNAL COMPONENTS CAN OCCUR.

THE PLUG-IN STYLE TIMER HAS THE SAME CASE DIMENSIONS AS THE FLANGE MOUNT STYLE EXCEPT IT HAS NO FLANGE AND IT IS ALSO SOCKET MOUNTABLE.

STANDARD PART NUMBERS	NOMINAL INPUT VOLTAGE	TIMING RANGE	EXTERNAL RESISTOR
ON DELAY PLUG-IN STYLE			
W388ACPSOX-1	120 VAC	0.1 TO 10 SECONDS	20,000 Ω
W388ACPSOX-2	120 VAC	1.0 TO 120 SECONDS	PER SECOND
W388CPSOX-1	24 VDC	0.1 TO 10 SECONDS	16,000 Ω
W388CPSOX-2	24 VDC	1.0 TO 120 SECONDS	PER SECOND
ON DELAY SURFACE MOUNT FLANGE STYLE			
W388ACQSOX-1	120 VAC	0.1 TO 10 SECONDS	20,000 Ω
W388ACQSOX-2	120 VAC	1.0 TO 120 SECONDS	PER SECOND
W388CQSOX-2	24 VDC	1.0 TO 120 SECONDS	
OFF DELAY PLUG-IN STYLE			
W388CPSRX-22	24 VDC	1.0 TO 120 SECONDS	16,000 Ω PER SECOND



DPDT, 12 AMPS

**THE CLASS 388 IS KNOB ADJUSTABLE
"ON" OR "OFF" DELAY FUNCTIONS.
DPDT, 12 AMP CONTACTS, ± 0.1 % REPEATABILITY,**



UL Recognized
File No. E43641



COMPLIES WITH REQUIREMENTS OF

- * IEC STANDARDS 947-4-1 AND 947-5-1 LOW VOLTAGE DIRECTIVE
- * IEC = INTERNATIONAL ELECTROTECHNICAL COMMISSION
- * CE TESTING AND EVALUATION PERFORMED BY THE UNDERWRITERS LABORATORIES AS A THIRD PARTY PARTICIPANT

GENERAL SPECIFICATIONS

TIMING

Operating Modes Available:	On delay, off delay
Timing Adjustments Available:	0.1 to 30 minutes
Repeatability:	±0.1% ±33 mS AC min. or ± 10 mS DC @ constant voltage & temperature
Timing Change Over Temperature and Voltage Range:	±10%
Timing Tolerance High End:	-0 to +40%
Timing Tolerance Low End:	+0 to -40%
Reset Time:	100 mS max.

CONTACTS

Contact Rating:	12 amps @ 120 VAC / 28 VDC resistive 1/3 Hp, 120 VAC, 1/2 Hp, 240 VAC NEMA B300 pilot duty
Contact Life:	100,000 operations @ 120 VAC, 12 amps resistive load 1,000,000 operations @ 120 VAC, 5 amps resistive load 2,000,000 operations @ 120 VAC, 2 amps resistive load
Mechanical Life:	5,000,000 operations

INPUT

Operating Voltage Range:	AC: 85% to 110%, DC: 80% to 110% of nominal
Temperature Range (Operate):	- 30°C to + 55°C
Temperature Range (Storage):	- 55°C to + 85°C
Steady State Input Current:	15 mA @ 230 VAC, 20 mA @ 120 VAC, 80 mA @ 24 VAC, 20 mA @ 48 VDC, 60 mA @ 24 VDC, 120 mA @ 12 VDC

PROTECTION

Reverse Polarity:	Yes - DC
Transient:	UL 508 Surge test: 5000V for 50 uS
Noise Immunity:	NEMA ICS2-230: 2500 VAC

DIELECTRIC STRENGTH

Coil to Contacts:	2000 V rms
Across Open Contacts:	1000 V rms

MECHANICAL

Mounting Position:	Any
Enclosure:	Polycarbonate dust cover
Terminals:	0.187 x 0.020" quick connect terminals
Weight:	96 grams approx.

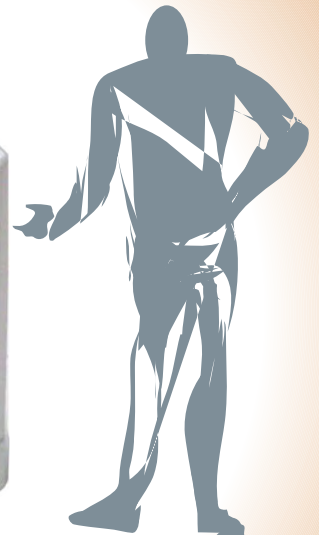

Mating Sockets

70-463-1: SCREW/DIN
70-124-1: SOLDER
70-178-1, 70-178-2: PRINTED CIRCUIT
70-124-2: QUICK CONNECT
See section 8, page 16, 17

DPDT, 12 AMPS

OUTLINE DIMENSIONS

DIMENSIONS SHOWN IN INCHES & (MILLIMETERS).

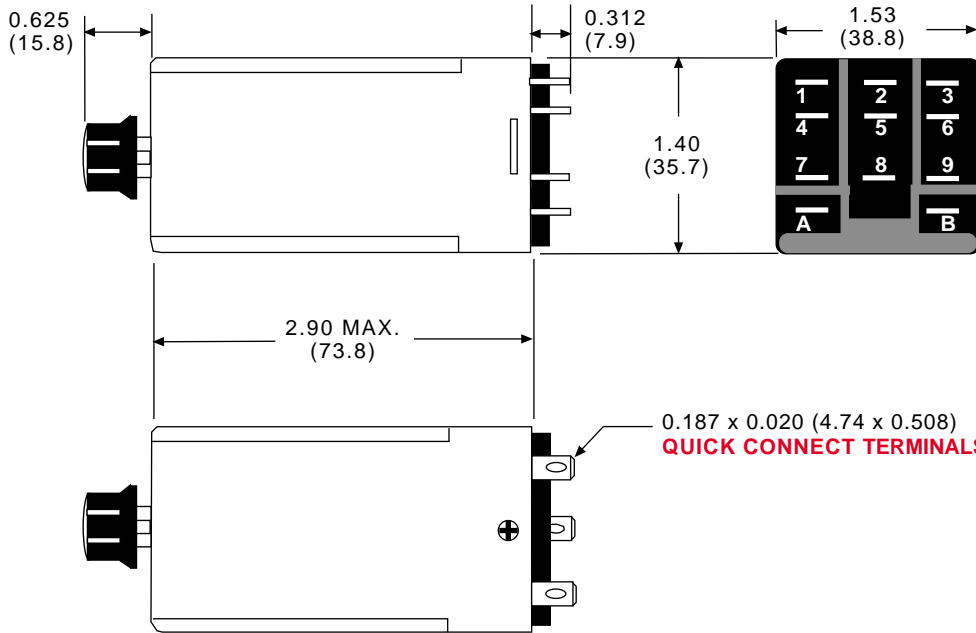

0.187 x 0.020 (4.74 x 0.508)
QUICK CONNECT TERMINALS



WIRING DIAGRAMS

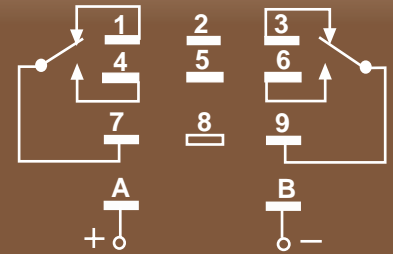

INPUT ON DELAY

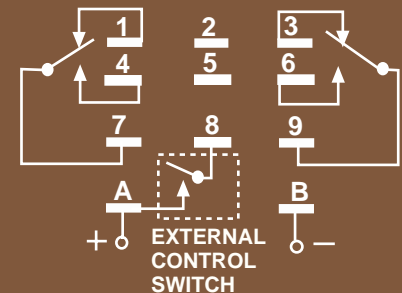

INPUT OFF DELAY

EXTERNAL SWITCH SHALL NOT BE CONNECTED TO ANY EXTERNAL LOAD OR VOLTAGE. DAMAGE TO INTERNAL COMPONENTS CAN OCCUR.



CALL FACTORY FOR OTHER VOLTAGES, TIME AND FUNCTIONS

STANDARD PART NUMBERS	NOMINAL INPUT VOLTAGE	TIMING RANGE
ON DELAY		
W388ACPSOX-42	120 VAC	0.1 TO 10 SECONDS
W388ACPSOX-44	120 VAC	1.0 TO 180 SECONDS
OFF DELAY		
W388CPSRX-2	24 VDC	0.1 TO 10 SECONDS
W388CPSRX-4	24 VDC	1.0 TO 180 SECONDS

DPDT, 12 AMPS

OUTLINE DIMENSIONS

DIMENSIONS SHOWN IN INCHES & (MILLIMETERS).

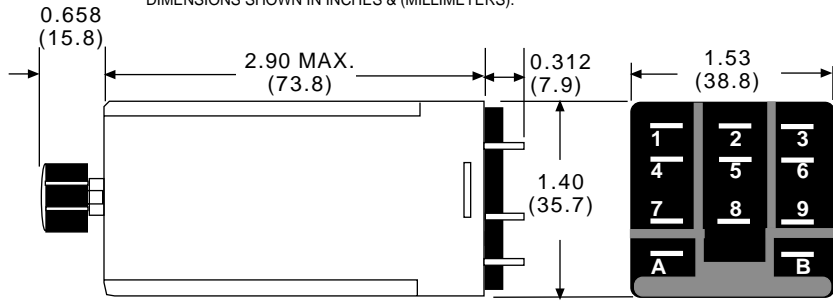

0.187 X 0.020 (4.74 X 0.508)
QUICK CONNECT TERMINALS

THE CLASS 388 ADJUSTABLE TRUE OFF DELAY RELAY COMBINES A SOLID STATE TIMING CIRCUIT WITH A STATE OF THE ART MAGNETIC LATCHING RELAY. THIS COMBINATION ALLOWS THE RELAY TO PULL-IN WHEN POWER IS APPLIED TO THE INPUT. TIMING STARTS WHEN POWER IS REMOVED FROM THE INPUT AND AT THE END OF THE PRESET TIMING PERIOD THE RELAY WILL DROPOUT.



COMPLIES WITH REQUIREMENTS OF
 * IEC STANDARDS 947-4-1 AND 947-5-1 LOW VOLTAGE DIRECTIVE
 * IEC = INTERNATIONAL ELECTROTECHNICAL COMMISSION
 * CE TESTING AND EVALUATION PERFORMED BY THE UNDERWRITERS LABORATORIES AS A THIRD PARTY PARTICIPANT

GENERAL SPECIFICATIONS

TIMING

Operating Modes Available: True off delay
 Timing Adjustments Available: 0.1 to 5 Minutes
 Repeatability
 (Repeat Accuracy when Stabilized): ±3% @ nominal voltage & 25°C
 Reset Time: 100 mS max.

CONTACTS

Contact Rating: 12 amps @ 120 VAC/28 VDC resistive
 1/3 Hp, 120 VAC, 1/2 Hp, 240 VAC
 NEMA B300 pilot duty
 Contact Life: 100,000 operations @ 120 VAC 12 amps resistive load
 1,000,000 operations @ 120 VAC 5 amps resistive load
 2,000,000 operations @ 120 VAC 2 amps resistive load
 Mechanical Life: 5,000,000 operations

INPUT

Temperature Range Operate: - 10°C to + 55°C
 Temperature Range Storage: - 40°C to + 85°C
 Input Current: 10 mA @ 120VAC, 15 mA @ 24VDC

PROTECTION

Reverse Polarity: Yes - DC
 Transient: 2000 VAC for 50 microseconds

DIELECTRIC STRENGTH

Coil to Contacts: 2000 V rms
 Across Open Contacts: 1000 V rms

MECHANICAL

Enclosure: Polycarbonate dust cover
 Mounting: Square base plug-in
 Terminals: 0.187" X 0.020" quick connect terminals
 Weight: 96 grams approx.



WIRING DIAGRAM

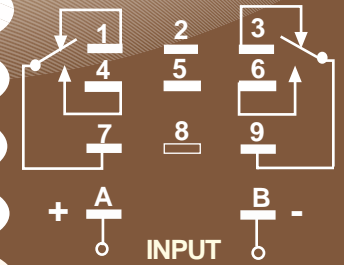

Mating Sockets

- 70-463-1: SCREW/DIN
 - 70-124-1: SOLDER
 - 70-178-1, 70-178-2: PRINTED CIRCUIT
 - 70-124-2: QUICK CONNECT
- See section 8, page 16, 17

STANDARD PART NUMBERS	NOMINAL INPUT VOLTAGE	TIMING RANGE
AC OPERATED		
W388ACPSRX-29	120 VAC	0.1 TO 10 SECONDS
W388ACPSRX-30	120 VAC	0.6 TO 60 SECONDS
DC OPERATED		
W388CPSRX-35	24 VDC	0.1 TO 10 SECONDS
W388CPSRX-36	24 VDC	0.6 TO 60 SECONDS

SPDT, 1.5 TO 15 AMPS



UL Recognized
File No. E62636

OUTLINE DIMENSIONS
DIMENSIONS SHOWN IN INCHES & (MILLIMETERS).

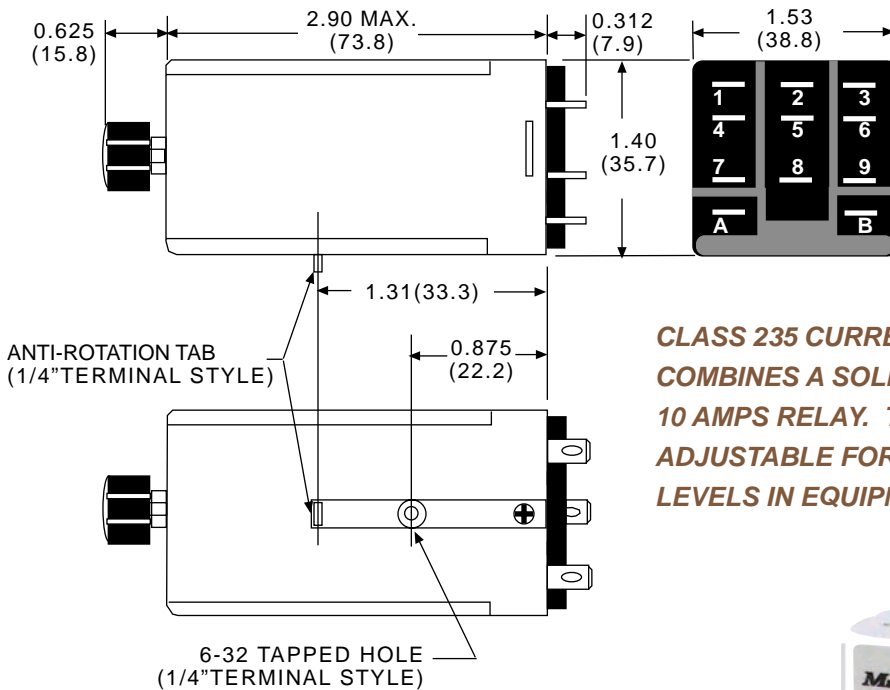

**CLASS 235 CURRENT SENSING RELAY
COMBINES A SOLID STATE SENSOR WITH A SPDT,
10 AMPS RELAY. THE SENSOR IS FIELD
ADJUSTABLE FOR DETECTING AC CURRENT
LEVELS IN EQUIPMENT.**



GENERAL SPECIFICATIONS

CURRENT SENSING:

Sense Current Range: 1.5 to 15 amps
Repeatability: ±2% @ constant voltage & temperature
±10% over voltage & temperature range

CONTACTS

Contact Rating: 10 amps @ 120 VAC, 6 amps @ 28 VDC
Transient: 2000 V rms for 5 microseconds
Contact Life: 200,000 operations @ rated load
Mechanical Life: 5,000,000 operations @ no load

INPUT

Input Current: 15 mA (1.7 VA)
Current Sensor Resistance: 5 milliohms
Temperature Range Operate: -10°C to +55°C
Temperature Range Storage: -40°C to +85°C

DIELECTRIC STRENGTH

Coil to Contacts: 2500 V rms
Across Open Contacts: 500 V rms

MECHANICAL

Enclosure: Polycarbonate dust cover
Terminals: 0.187 or 0.250 quick connect terminals
Mounting: Square base plug-in
Mounting Bracket: Optional
Weight: 113 grams approx.

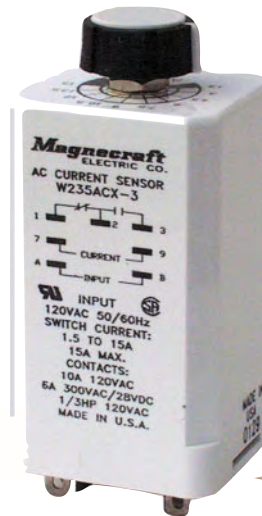

WIRING DIAGRAM

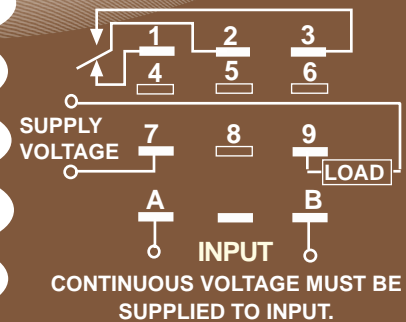

Mating Sockets

- 70-463-1: SCREW/DIN
 - 70-124-1: SOLDER
 - 70-178-1, 70-178-2: PRINTED CIRCUIT
 - 70-124-2: QUICK CONNECT
- See section 8, page 16, 17

STANDARD PART NUMBERS	NOMINAL INPUT VOLTAGE	CURRENT RANGE	TERMINAL SIZE
W235ACX-2	120 VAC	1.5 TO 15 AMPS	0.250"
W235ACX-3	120 VAC	1.5 TO 15 AMPS	0.187"

SPST, DPDT & 3PDT, 10 AMPSUL Recognized
File No. E13224

THE CLASS 286 ON DELAY & 287 OFF DELAY TIME DELAY RELAYS HAVE TIMING RANGES FROM 0.1 TO 300 SECONDS. THE 286 TIMER HAS UP TO THREE POLES AND THE 287 TIMER HAS UP TO TWO POLES. THE 286 & 287 TIME DELAY RELAYS ARE RATED AT 10 AMPS, 120/240 VAC, 28 VDC.

GENERAL SPECIFICATIONS

TIMING

Operating Modes Available:	On delay, off delay, Interval
Timing Adjustments Available:	0.1 to 300 minutes
Repeatability (Repeat Accuracy when Stabilized):	± 3% @ 20°C to 25°C (AC +16 mS)
Reset time:	150 mS max.

CONTACTS

Contact Material:	Silver cadmium oxide.
Contact Rating:	10 amps @ 120 / 240 VAC 10 amps @ 28 VDC 1/3 Hp @ 120 VAC 1/2 Hp @ 240 VAC
Contact Life:	100,000 operations @ rated load
Mechanical Life:	10,000,000 operations @ no load

INPUT

Operating Voltage Range:	AC: 85% , DC: 80% of nominal
Temperature Range (Operate):	10°C to +70 °C
Max. Allowed Voltage:	110% of nominal voltage

PROTECTION

Reverse Polarity:	Yes - DC
Transient:	2000 V for 5 mS

DIELECTRIC STRENGTH

Coil to Contacts:	1500 V rms
Across Open Contacts:	500 V rms

MECHANICAL

Operating Position:	Any
Enclosure:	Clear polycarbonate
Weight:	142 grams approx.



Mating Sockets

70-463-1: SCREW/DIN
70-124-1: SOLDER
70-178-1, 70-178-2: PRINTED CIRCUIT
70-124-2: QUICK CONNECT
 See section 8, page 16, 17

1, 2 & 3 POLE, 10 AMPS

ORDERING CODE FOR RELAYS

286 **XAX** **C** **001** **F** **120A**

CLASS:

286: ON DELAY
287: OFF DELAY

CONTACT ARRANGEMENTS:

XAX: SPDT
XBX: DPDT
XCX: 3PDT (286 ONLY)

MOUNTING OPTIONS:

C: PLUG-IN
C1 NOTE 1: 1BRACKET
CS1 NOTE 1: TOP STUD
C2: SIDE TAPPED HOLE
CS2: SIDE STUD

TIMING RANGES:

0.1 - 1.0 SEC: **CODE 001**
0.2 - 2.0 SEC: **CODE 002**
1.0 - 10 SEC: **CODE 010**
3.0 - 30 SEC: **CODE 030**
6.0 - 60 SEC: **CODE 060**
18 - 180 SEC: **CODE 180**
30 - 300 SEC: **CODE 300**

ADJUSTMENT OPTIONS

ADJUSTMENT KNOB: **NO CODE**
FIXED DELAY: **SPECIFY FIXED TIME & CODE F ***
REMOTE ADJUSTMENT: **CODE R ****

OPERATING VOLTAGE:

24, 48, 120, 240 **ADD "A" FOR AC COILS**
12, 24, 48, 115-125 **ADD "D" FOR DC COILS**

OUTLINE DIMENSIONS

DIMENSIONS SHOWN IN INCHES & (MILLIMETERS).

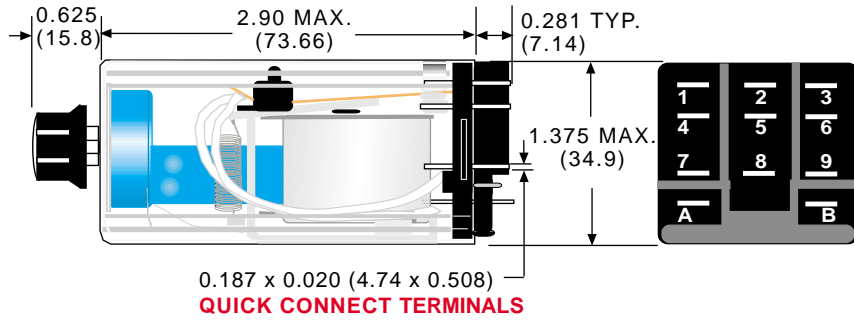

QUICK CONNECT TERMINALS

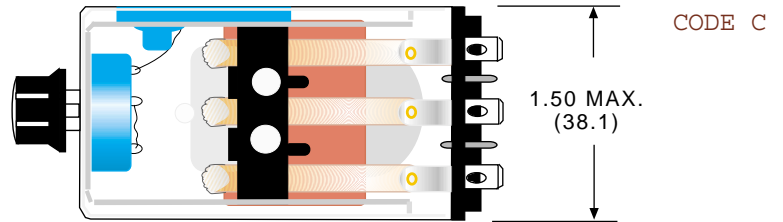

(F * Models) - timing code does not apply. Specify single delay time requirement
(R ** Models) - Available only for SPDT and DPDT models. External potentiometer required.
Example of typical fixed time delay relay part number- **286XBXCS1-3.5F-120A**
(ON DELAY, DPDT, TOP STUD, 3.5 SEC FIXED, 120 VAC COIL INPUT)

NOTE 1:

BRACKET & TOP STUD NOT AVAILABLE WITH ADJUSTABLE TIMING.

WIRING DIAGRAM

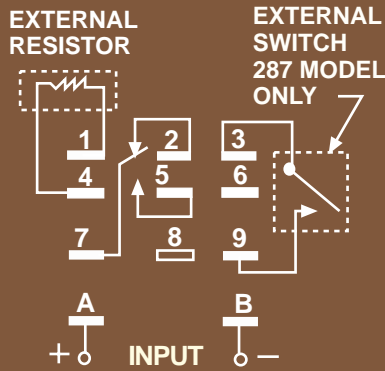

**286XAX (SPDT)
287XAX (SPDT)**

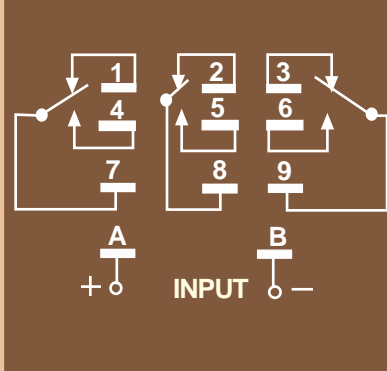

286XCX (3PDT)

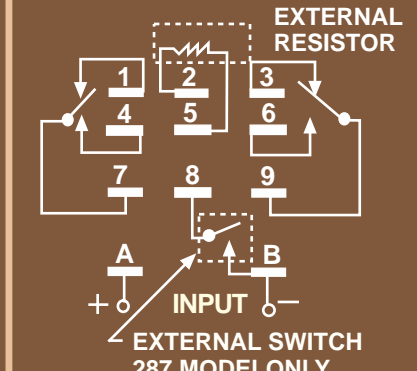

**286XBX (DPDT)
287XBX (DPDT)**



ORDERING CODE FOR RELAYS

SPDT, DPDT & 3PDT 10 AMPS



UL Recognized
File No. E13224

326 XAX 48P 001 F 120A

CLASS:
326: ON DELAY
327: OFF DELAY

CONTACT ARRANGEMENTS:
XAX: SPDT
XBX: DPDT
XCX: 3PDT

CONSTRUCTION STYLE:
OCTAL STYLE PLUG-IN: **CODE 48P**
NON STANDARD WIRING: **CODE 48P-K**

TIMING RANGES:
0.1 - 1.0 SEC: **CODE 001**
0.2 - 2.0 SEC: **CODE 002**
1.0 - 10 SEC: **CODE 010**
3.0 - 30 SEC: **CODE 030**
6.0 - 60 SEC: **CODE 060**
18 - 180 SEC: **CODE 180**
30 - 300 SEC: **CODE 300**

ADJUSTMENT:
ADJUSTMENT KNOB): **NO CODE**
FIXED DELAY: **SPECIFY FIXED TIME & CODE F ***
REMOTE ADJUSTMENT: **CODE R ****

OPERATING VOLTAGE:
24, 48, 120, 240 **ADD "A" FOR AC COILS**
12, 24, 48, 115-125 **ADD "D" FOR DC COILS**

F * Models) - timing code does not apply. Specify single delay time requirement
(R ** Models)- Available only for SPDT and DPDT models.
External fixed or Adjustable resistor required.
Example of typical fixed time delay relay part number - **326XBX48P3.5F-120A**
(ON DELAY, DPDT, OCTAL PLUG, 3.5 SEC FIXED, 120 VAC POWER INPUT)

GENERAL SPECIFICATIONS

TIMING

Repeatability: DC: $\pm 3\%$ @ 20°C, AC: $\pm 3\%$ +16 mS @ 20°C
Accuracy: Adjustable $\pm 10\%$ within temperature & voltage range
Switching Time of Output Relay: 20 mS
Min. Waiting Time Before Starting Next Cycle (Reset Time): 100 mS (for timing cycle up to 60 sec)
150 mS (for timing cycle 60 to 300 sec)

CONTACTS

Contact Material: Silver cadmium oxide
Rating: 10 amps @ 120 / 240 VAC, 10 amps @ 30 VDC,
1/3 Hp @ 120 VAC, 1/2 Hp @ 240 VAC
Electrical Life: 100,000 operations @ rated load
Mechanical Life: 10,000,000 operations @ no load

INPUT

Nominal Voltage: AC: 24 to 240, DC: 12 to 125
Minimum Oper. Voltage: AC - 85% of nominal; DC - 80% of nominal
Max. Allowed Voltage: 110% of nominal voltage
Ambient Temperature Rating: -10°C to +70 °C

DIELECTRIC STRENGTH

Across Open Contacts: 500 V rms
Coil to Contacts: 1500 V rms
Transient Protection: 2000 VAC for 5 mS

MECHANICAL

Enclosure: Clear polycarbonate
Weight: 142 grams approx.



Mating Sockets
70-750D8-1, 70-750D11-1,
70-464-1, 70-465-1: **SCREW/DIN**
70-169-1, 70-170-1: **SCREW/PANEL**
See section 8, page 7 - 12

1, 2 & 3 POLE, 10 AMPS

OUTLINE DIMENSIONS

DIMENSIONS SHOWN IN INCHES & (MILLIMETERS).

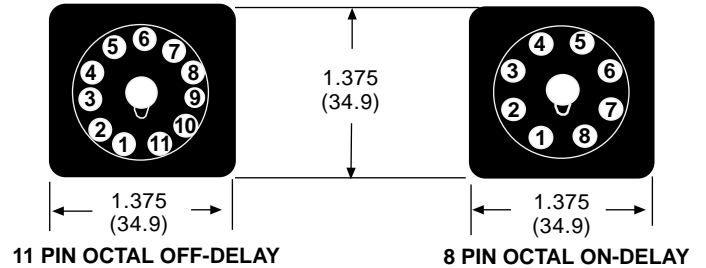
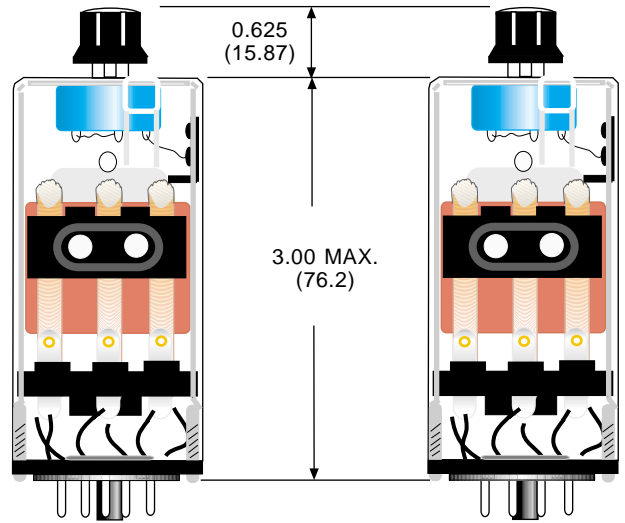

11 PIN OCTAL OFF-DELAY

8 PIN OCTAL ON-DELAY

WIRING DIAGRAMS

- * External Resistor for remote timing adjustment on models 326 or 327 with Code R.
- ** Observe Polarity on DC input models

MODELS WITH INTERNAL TIMING RESISTOR

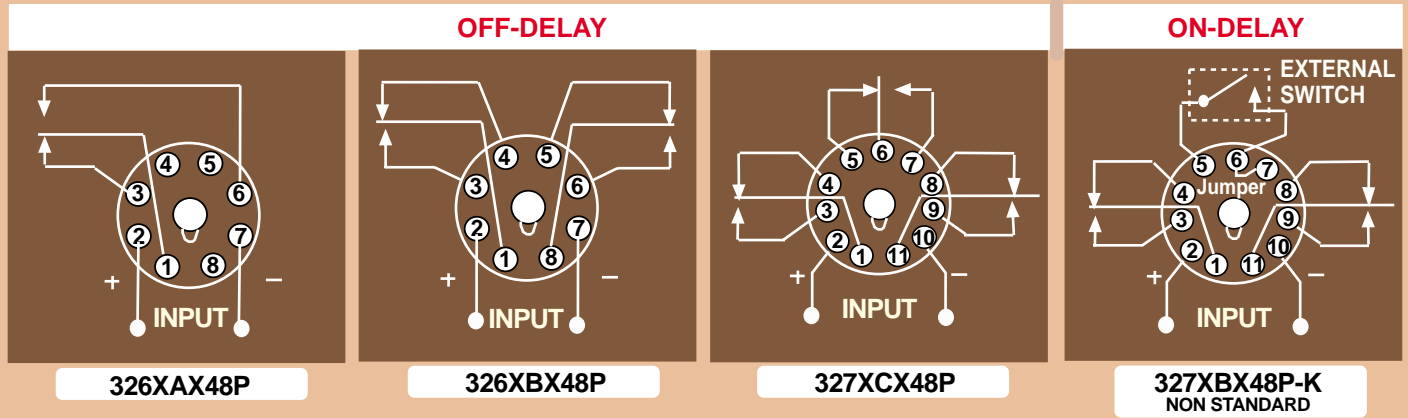

MODELS WITH EXTERNAL (REMOTE) TIMING RESISTOR

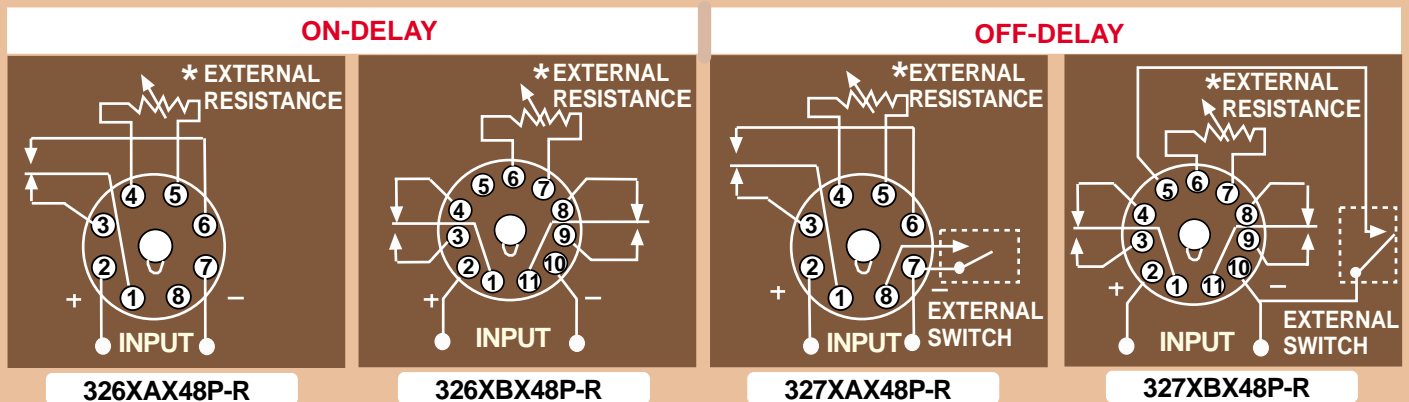

UL CONTACT LOAD RATINGS TABLE

POLES	CURRENT OR HORSE POWER	LOAD VOLTAGE	LOAD VOLTAGE FREQUENCY	TYPE OF LOAD
ALL STYLES	10 AMP	120 VAC	50/60 Hz	RESISTIVE
	5 AMP	240 VAC	50/60 Hz	RESISTIVE
	10 AMP	28 VDC	DC	RESISTIVE
	0.5 AMP	125 VDC	DC	RESISTIVE
	3 AMP	120 VAC	50/60 Hz	INDUCTIVE
	1 AMP	240 VAC	50/60 Hz	INDUCTIVE
	3 AMP	28 VDC	DC	INDUCTIVE
	0.1 AMP	125 VDC	DC	INDUCTIVE
SUFFIX "69" WITH BLOWOUT MAGNET FOR DC SWITCHING (NOT UL OR CSA)				
SPST-NO	1.5 AMP	125 VDC	DC	RESISTIVE
SPST-NO-DM	4 AMP	125 VDC	DC	RESISTIVE
SPST-NO	0.5 AMP	250 VDC	DC	RESISTIVE
SPST-NO-DM	1.5 AMP	250 VDC	DC	RESISTIVE
SPST-NO	0.5 AMP	125 VDC	DC	INDUCTIVE
SPST-NO-DM	1.5 AMP	125 VDC	DC	INDUCTIVE
SPST-NO	150 mA	250 VDC	DC	INDUCTIVE
SPST-NO-DM	0.5 AMP	250 VDC	DC	INDUCTIVE

DPDT, 3PDT, 4PDT, DPDT WITH 1 N.C & 1 N.O., DPDT WITH 2 N.O., 10 AMPS

INSTANTANEOUS CONTACTS AVAILABLE



UL Recognized
File No. E13224



Class 246 CSA
Certified



LISTED
367G

UL Listed when used with type 27390 socket

CONTACTS CAN SWITCH 30 AMP LOADS AND CARRY 10 AMPS CONTINUOUSLY AT VOLTAGES SHOWN IN UL CONTACT LOAD RATINGS TABLE.

THE CLASS 246 & 247 TIME DELAY RELAYS ARE ON-DELAY OR OFF DELAY, WITH TIMING RANGES FROM 0.1 TO 300 SECONDS. BOTH TIMERS INCORPORATE THE PROVEN INDUSTRIAL WORKHORSE CLASS 219 FRAME ALONG WITH A SOLID STATE TIMING MODULE. PRODUCTS ARE AVAILABLE WITH A VARIETY OF POLE AND CONTACT CONFIGURATIONS. A LARGE CHOICE OF OPTIONS IS AVAILABLE AND SWITCH UP TO 30 AMP LOADS.

GENERAL SPECIFICATIONS

TIMING

Operating Modes Available:	On delay, off delay
Repeatability:	± 3% @ 25°C (AC +16 mS)
Accuracy:	Adjustable ± 10% within temperature & voltage range
Recycle Time:	150 mS 60 to 300 Sec
False Contacting:	No false contacting if power is interrupted during timing cycle

CONTACTS

Contact Material:	Silver cadmium oxide - gold diffused
Electrical Life:	100,000 operations @ rated load
Mechanical Life:	10,000,000 operations @ no load

INPUT

Coil Voltage	
Minimum Operate Voltage:	AC - 85% of nominal DC - 80% of nominal
Ambient Temperature Rating:	AC: -10°C to +45°C @ rated operation, DC: -10°C to +70°C @ rated operation
Max. Allowed Voltage:	110% of nominal voltage

PROTECTION

Reverse Polarity:	Yes - DC
-------------------	----------

DIELECTRIC STRENGTH

Across Open Contacts:	500 V rms
Coil to Contacts:	1500 V rms
Transient Protection:	2000V for 5 mS

MECHANICAL

Enclosure:	Clear polycarbonate
Weight:	227 grams approx.

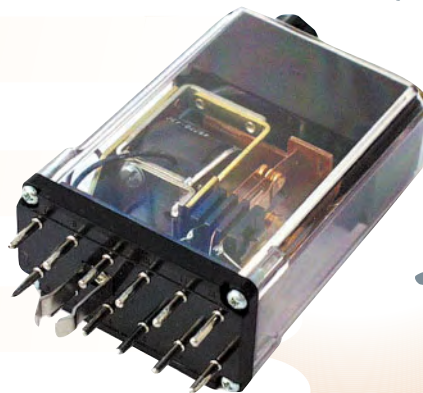

**12 Pin Versions Mating Socket:
27390**

**14 Pin Versions Mating Socket:
33377**

See section 8, page 27

ORDERING CODE FOR RELAYS

247 **XBX** **P** **L** **-010 -120A**

CLASS:

246: ON DELAY,
247: OFF DELAY,

CONTACT ARRANGEMENTS:

XBX: (2 FORM "C")
XCX: (3 FORM "C")
ABA: (1 FORM A & 2 FORM C & 1 FORM B).
BBX: (2 FORM A & 2 FORM C) 246 ONLY.

STANDARD FEATURES:

PLUG-IN WITH POLYCARBONATE COVER: **CODE P**

OPTIONS:

INDICATOR LAMP: **CODE L**
MANUAL ACTUATOR: **CODE M**
BIFURCATED CONTACTS (5 AMPS MAX): **CODE 33**
PERMANENT MAGNET, BLOWOUT: **CODE 69**
ADJUSTMENT KNOB): **NO CODE**
REMOTE ADJ. (EXT POT REQUIRED) : **CODE R**
LOCKING SHAFT POT: **CODE 8**
INSTANTANEOUS CONTACTS: **CALL**

TIMING RANGES:

0.1 - 1.0 SEC: **CODE 001**
0.2 - 2.0 SEC: **CODE 002**
1.0 - 10 SEC: **CODE 010**
3.0 - 30 SEC: **CODE 030**
6.0 - 60 SEC: **CODE 060**
18 - 180 SEC: **CODE 180**
30 - 300 SEC: **CODE 300**
OVER 300 SEC: **CALL**
FIXED: **CODE F (EX. 3F)**

OPERATING VOLTAGE:

24, 48, 120, 240 **ADD "A" FOR AC COILS**
12, 24, 48, 110-125, 250 **ADD "D" FOR DC COILS**

DPDT, 3PDT, 4PDT
DPDT WITH 1 N.C & 1 N.O.,
DPDT WITH 2 N.O., 10 AMPS

OUTLINE DIMENSIONS
DIMENSIONS SHOWN IN INCHES & (MILLIMETERS).

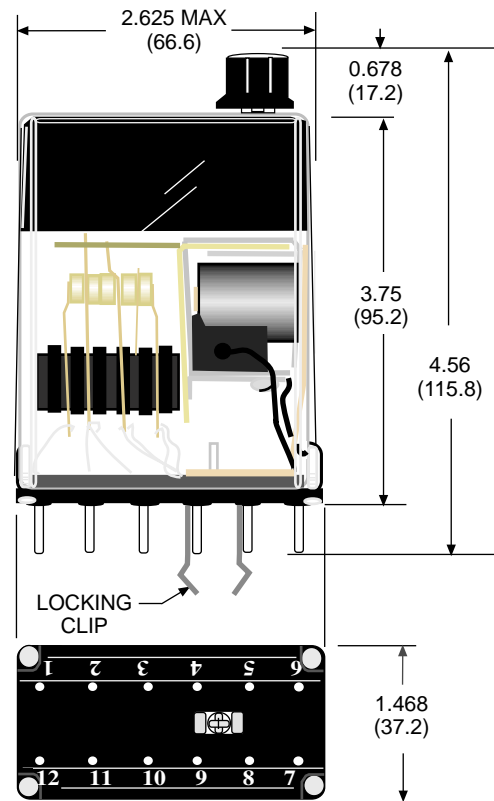

WIRING DIAGRAMS

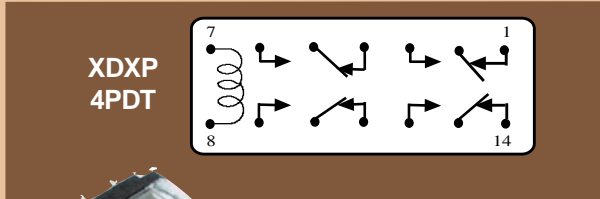
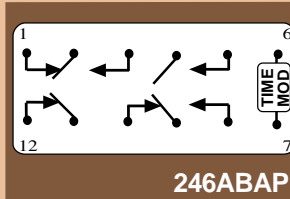
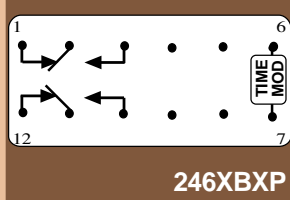
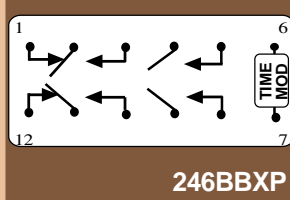
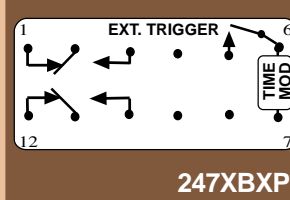
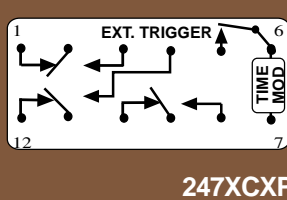

CALL FACTORY FOR
OTHER AGASTAT
ALTERNATIVES

**SPDT, 13 AMPS
& DPDT, 10 AMPS**



UL Recognized
File No. E62636

CLASS 236 VOLTAGE SENSING RELAYS COMBINE A SOLID STATE SENSOR WITH A SPDT, 13 AMP OR DPDT 10 AMP RELAY. PULL-IN & DROPOUT VOLTAGES ARE INDEPENDENTLY ADJUSTABLE. THE 236 CAN BE USED EITHER AS A OVER OR UNDER VOLTAGE DETECTING RELAY. STATUS L.E.D. INCLUDED.

APPLICATIONS: BROWNOUT PROTECTION, WARNING OF UNDER VOLTAGE CONDITIONS AND OVER VOLTAGE PROTECTION. PREVENTS EQUIPMENT BURNOUT.

**OPTIONAL TIME DELAY
AVAILABLE IN OCTAL
PIN VERSION**

GENERAL SPECIFICATIONS

VOLTAGE SENSING:

Nominal Input: 24, 120, 240, 480 VAC 50/60Hz, 24 VDC.
other AC & DC voltages available

Adjustment Range: Pull-in 75% to 115% of nominal voltage,
Dropout 75% to 95% of pickup setting

Repeatability: ± 1% @ constant voltage & temperature

CONTACTS

Contact Material: Silver cadmium oxide

Contact Rating: **SPDT:** 13 amps @ 240 VAC, 28 VDC Res.
1/3 Hp @ 120 VAC, 1/2 Hp @ 240 / 480 AC,
3 amps @ 480 VAC, NEMA B300 pilot duty
DPDT: 10 amps @ 240 VAC / 28 VDC Res.
1/3Hp @ 120 VAC, 1/2 Hp 240 VAC.
NEMA B300 pilot duty

Electrical Life: 100,000 operations @ rated load

Mechanical Life: **SPDT:** 5,000,000 operations
DPDT: 10,000,000 operations

INPUT

Input Current: 15 mA (1.7 VA) @ 120 VAC
12 mA 240 VAC max. (2.9VA)
7 mA max. 480 AC (3.41 VA)

Temperature Range Operate: - 30°C to + 55°C

Temperature Range Storage: - 40°C to + 85°C

DIELECTRIC STRENGTH

Coil to Contacts: 2500 V rms

Across Open Contacts: 1000 V rms

Transient: UL 508 surge 5000 V for 50 microseconds

Noise Immunity: NEMA ICS2-230, 2500 VAC.

MECHANICAL

Enclosure: Polycarbonate dust cover

Terminals: 0.187 quick connect terminals, or 8 pin octal base

Power "ON" Indicator: L.E.D. (green)

Weight: 124.4 grams, 155.5 grams (8 pin octal)

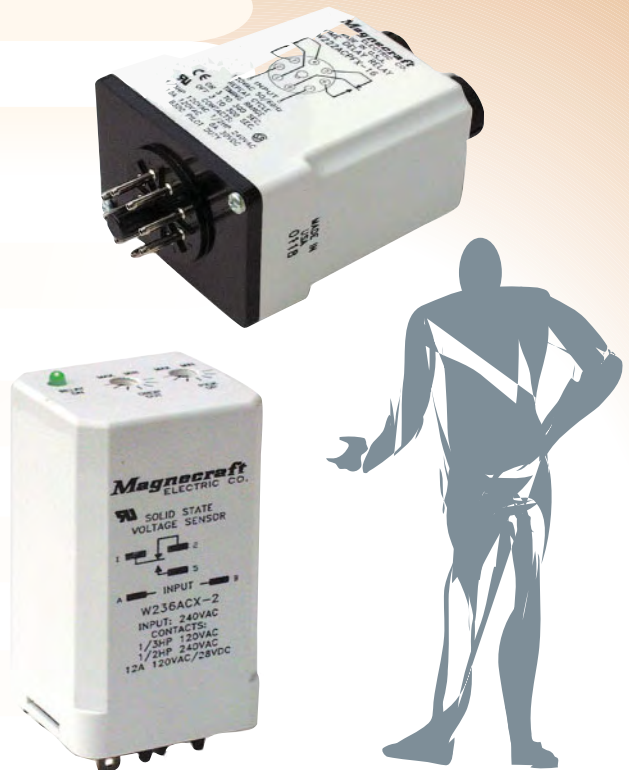

Mating Sockets

**70-750D8-1, 70-750D11-1,
70-464-1, 70-465-1: SCREW/DIN
70-169-1, 70-170-1: SCREW/PANEL
See section 8, page 7 - 12
70-463-1: SCREW/DIN
70-124-1: SOLDER
70-178-1, 70-178-2: PRINTED CIRCUIT
70-124-2: QUICK CONNECT
See section 8, page 16, 17**

SPDT, 13 AMPS & DPDT, 10 AMPS

OUTLINE DIMENSIONS
DIMENSIONS SHOWN IN INCHES & (MILLIMETERS).

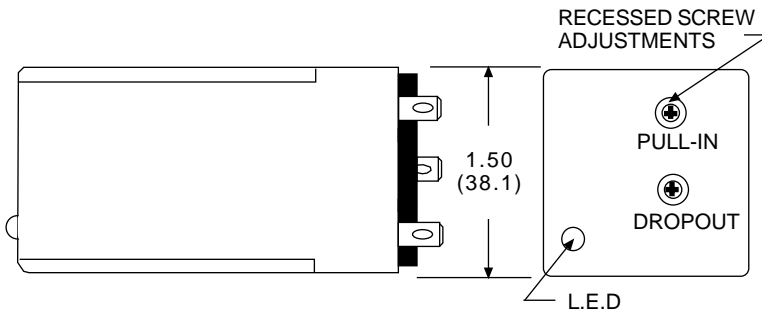
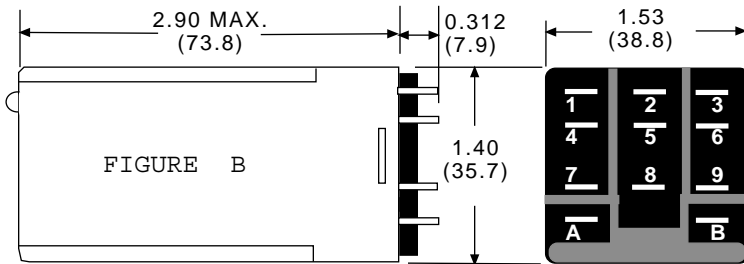
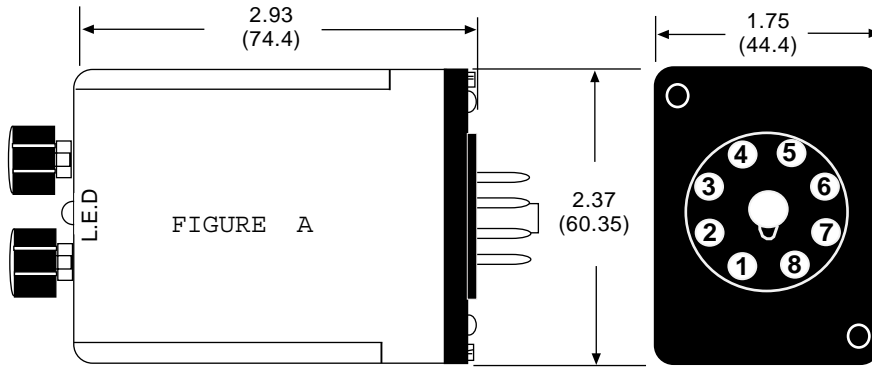

WIRING DIAGRAM

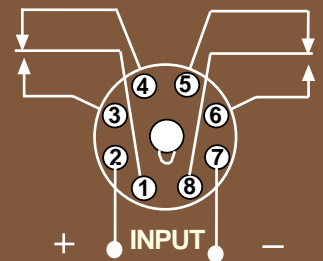

8 PIN OCTAL

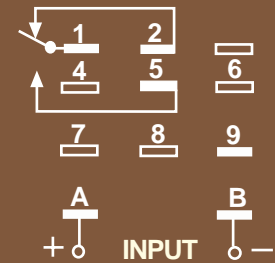

SQUARE BASE
CONTINUOUS VOLTAGE MUST BE SUPPLIED TO INPUT.

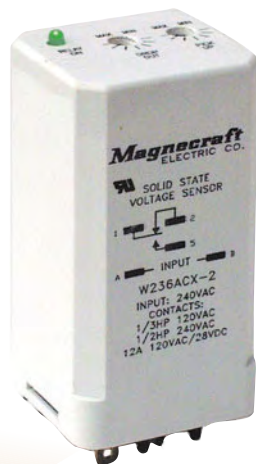

STANDARD PART NUMBERS	FIG.	NOMINAL INPUT VOLTAGE	VOLTAGE PULL-IN RANGE	VOLTAGE DROP-OUT RANGE
W236ACPX-1	A	120 VAC	92 TO 140 VAC	75% TO 95% OF PICKUP VOLTAGE SETTING
W236ACPX-4	A	24 VAC	20 TO 30 VAC	
W236CPX-2	A	24 VDC	20 TO 30 VDC	
W236ACX-1	B	120 VAC	90 TO 138 VAC	
W236ACX-2	B	208 / 220 / 120 VAC	180 TO 276 VAC	
W236ACX-3	B	480 VAC	360 TO 552 VAC	



SECTION 4 CROSS REFERENCE GUIDE

MAGNECRAFT & STRUTHERS-DUNN	POTTER & BRUMFIELD	CUTLER HAMMER	NTE	SIEMENS	SQUARE D
W211ACPSOX-18	CDB-38-70001				
W211ACPSOX-5	CDB-38-70003/CGB-38-70010S/ CHB-38-70001/CKB-38-70010/ CB-1003B-70	MTON1P120A		OND-0110-120A	9050JCK11V20
W211ACPSOX-7	CKB-38-70180/CHB-38-70003/ CB-1005B-70/CDB-38-70005	MTON2P120A		OND-1180-120A	9050JCK15V20
W211ACPSOX-8	CGB-38-70005M		R28-11A10-120M		
W211ACPSOX-60	CGB-38-70010M				9050JCK16V20
W211ACPSOX-61					9050JCK17V20
W211ACPSOX-62	CGB-38-70050M				9050JCK18V20
W211ACPSOX-63	CB-1007B70				9050JCK19V20
W211CPSOX-1	CHD-38-30001/CB-1028D-30/CDD-38-30003			OND-0110-24D	
W211ACPSRX-5	CHB-38-70011/CB-1021B-78	MTOF1P120A		OFD-0110-120A	9050JCK21V20
W211ACPSRX-7	CHB-38-70013	MTOF2P120A		OFD-1180-120A	9050JCK25V20
W211CPSRX-1	CHD-38-30011				
W211CPSRX-3	CHD-38-30013/CDD-38-30008				
MAGNECRAFT & STRUTHERS-DUNN	POTTER & BRUMFIELD	SQUARE D			
TDRPRO-5000	CNM5, CNS-35-96, CNS-35-76	JCK60, JCK70			
TDRPRO-5002	CN1, CNS-35-92, CNS-35-72				
MAGNECRAFT & STRUTHERS-DUNN	POTTER & BRUMFIELD				
W67CPSOX-1	R123012X2E1				
W67CPSOX-2	R123024X2E1				
MAGNECRAFT & STRUTHERS-DUNN	SQUARE D				
W222ACPFX-11	9050JCK51V20				
W222ACPFX-27	9050JCK57V20				
MAGNECRAFT & STRUTHERS-DUNN	POTTER & BRUMFIELD	CUTLER HAMMER	MIDTEX		
W388ACPSOX-1	CLF-41-70010				
W388ACPSOX-2			614-12T400		
W388CPSOX-1	CLH-41-30010				
W388CPSOX-2			614-12C400		
W388CPSRX-22			612-12C400		
W388ACPSOX-42		MTON1B120A	612-43T100		
W388ACPSOX-44		MTON2B120A	614-43T400		
W388CPSRX-2			612-43C100		
W388CPSRX-4			612-43C400		

THE CROSS REFERENCE IS INTENDED TO MATCH FOOT PRINT, INTERNAL WIRING, AND CONTACT LOAD RATINGS.

CONSTRUCTION FEATURES AND GENERAL SPECIFICATIONS SHOULD BE COMPARED IF EXACT REPLACEMENT IS REQUIRED.



FOR TIME DELAY APPLICATION ENGINEERING ASSISTANCE

Scott Heilman, PRODUCT MANAGER
 FAX: (843) 395-8530
 EMAIL: sheilman@magnecraft.com
 FAX ON DEMAND: 1-800-891-2957
 DOCUMENT: 500

U. S. A.

TELEPHONE: (843) 393-5778
 FAX: (843) 393-4123
 WEBSITE: www.magnecraft.com
 EMAIL: info@magnecraft.com

EUROPE

TELEPHONE: 4989 / 75080310
 FAX: 4989 / 7559344
 WEBSITE: www.magnecraft.com
 EMAIL: renatesteinback@magnecraft.de

X-ON Electronics

Largest Supplier of Electrical and Electronic Components

Click to view similar products for [Time Delay & Timing Relays](#) category:

Click to view products by [Magnecraft](#) manufacturer:

Other Similar products are found below :

[7012GD](#) [7012L10BN](#) [7012L10DY1N](#) [7012L10FN](#) [7012L10HN](#) [7012L26K](#) [7012L8AI2LLSN](#) [7012L8BN](#) [7012L8KN](#) [7012OBILM](#)
[7012OIT](#) [7012PALL](#) [7012PDM](#) [7012PFX](#) [7022L10DN](#) [7022L8BN](#) [7022L8EN](#) [7022L8HN](#) [7022X3D](#) [7024NB](#) [7024SCT](#) [88256455](#) [H3BG-](#)
[N8H](#) [AC110V](#) [H3CRF8AC2448DC1248](#) [1423151-3](#) [1423154-8](#) [1423462-7](#) [1423618-6](#) [1423151-5](#) [1423156-7](#) [1423618-4](#) [1472925-1](#)
[2112AH1SDC947](#) [2122DH1NJC467](#) [2122DH1PE](#) [2-1617805-2](#) [2-1617805-6](#) [K61C-08](#) [286XCXC-300-24D](#) [SCBRX022XXACXAC991](#)
[SHS10S110A](#) [SHS20M220A](#) [1755074-5](#) [SSC12AKA](#) [FAASPRING2](#) [2112DH3NDC50-13](#) [2-1437479-8](#) [2-1617805-1](#) [2-1617805-3](#) [2-](#)
[1617805-7](#)