

Features and Benefits

- **1.0mm Hall Elements Spacing**
- **Magnetic Type: Bipolar Switch**
- **Operating Voltage Range:**
Supply Voltage 2.8~24V
- **Specified Operating Temperature Range:**
From -40°C~150°C
- **High Magnetic Sensitivity**
 $B_{OP}=24\text{Gauss}$, $B_{RP}=-24\text{Gauss}$ (typical)
- **Lead Free Package**
Flat TO-94, SOP-8
- **High ESD Rating**
- **RoHS Compliant**
2011/65/EU

Applications

- **Magnetic encoder**
- **Speed detection**
- **Direction detection**

Family Members

Part number	Description
MT1450A-EN	Flat TO-94 package, bulk packaging (1000pcs/bag)
MT1450CT-EN	SOP-8 package, tape and reel packaging (3000pcs/bag)

General Description

The MT1450-EN is a dual channel switch hall sensor with two hall sensing elements, it output two digital signal for speed and direction processing.

The MT1450-EN internally includes two hall sensing elements located 1.0mm apart, an on-chip hall voltage generator, voltage regulator for operation with supply voltage 2.8 to 24V, temperature compensation circuitry, small-signal amplifier, Hall sensor with dynamic offset cancellation system, Schmitt trigger and open-drain output. It is easy processing of speed and direction signals.

The MT1450-EN family provides a variety of packages to customers: flat TO-94 for through-hole mount and SOP-8 for surface mount. All packages are RoHS compliant.

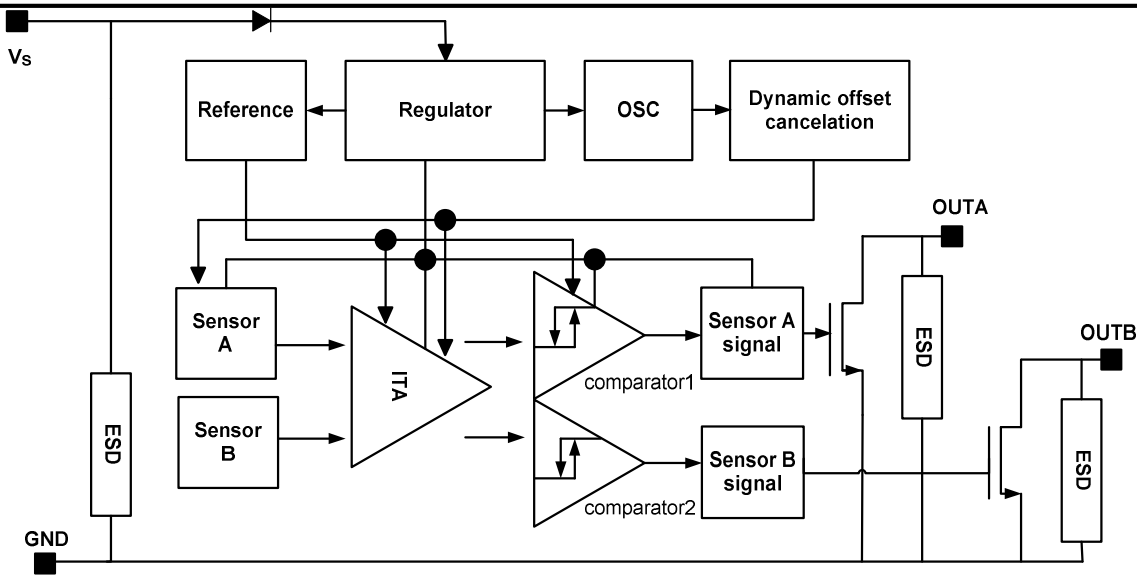

Functional Block Diagram

Definition of Magnetic Parameters

B_{OP} : Operating point, magnetic flux density applied on the branded side of the package which turns the output driver ON ($V_{OUT}=Low$)

B_{RP} : Release point, magnetic flux density applied on the branded side of the package which turns the output driver OFF ($V_{OUT}=High$)

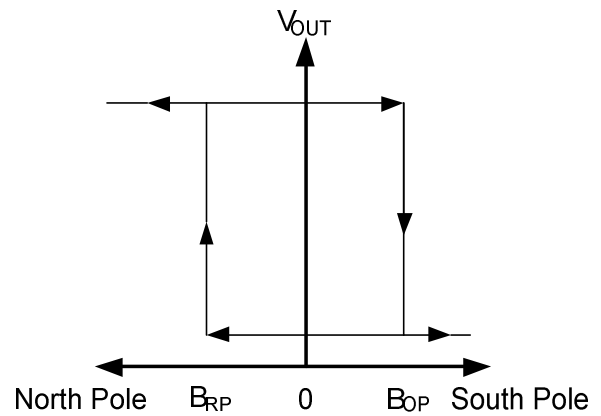

B_{HYST} : Hysteresis window, $|B_{OP}-B_{RP}|$

Pin Description

MT1450A-EN

Name	Number	Description
V_s	1	Power Supply
OUTA	2	Output Signal A
OUTB	3	Output signal B
GND	4	Ground

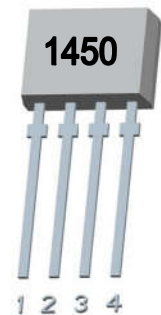

MT1450CT-EN

Name	Number	Description	Name	Number	Description
GND	1	Ground	V_s	5	Power Supply
OUTA	2	Output Signal A	NC	6	No Connection
GND	3	Ground	NC	7	No Connection
OUTB	4	Output signal B	NC	8	No Connection

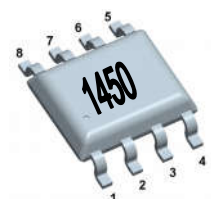

Electrical and Magnetic Characteristics

Absolute Maximum Ratings

Absolute maximum ratings are limiting values to be applied individually, and beyond which the serviceability of the circuit may be impaired. Functional operability is not necessarily implied. Exposure to absolute maximum rating conditions for an extended period of time may affect device reliability.

Absolute maximum ratings: all voltages listed are referenced to GND.

Symbol	Parameters	Min	Max	Units
V_S	Supply Voltage	-	27	V
V_{RCC}	Reverse Battery Voltage	-27	-	V
V_{OUT}	Output Voltage	-	27	V
I_{OUT}	Continuous output current	-	50	mA
T_A	Operating Ambient Temperature	-40	150	°C
T_S	Storage temperature	-50	165	°C
T_J	Junction temperature	-	165	°C
B	Magnetic flux	No Limit		Gauss

MT1450-EN Series Specifications

At $T_A = -40^{\circ}\text{C}$ to 150°C , $V_S = 2.8\text{V}$ to 24V (unless otherwise specified)

Symbol	Parameter	Test Condition	Min	Typ	Max	Units
V_S	Supply Voltage	Operating	2.8	5	24	V
I_S	Supply Current	$B < B_{RP}$	-	4.6	7	mA
V_{SON}	Output Saturation Voltage	$I_{OUT} = 20\text{mA}$, $B > B_{OP}$	-	-	0.4	V
I_{OFF}	Output Leakage Current	$B < B_{RP}$, $V_{OUT} = 24\text{V}$	-	-	10	μA
$T_R^{1,2}$	Output Rise Time	$R_L = 1\text{Kohm}$, $C_L = 20\text{pF}$	-	-	1.0	μs
$T_F^{1,2}$	Output Fall Time	$R_L = 1\text{Kohm}$, $C_L = 20\text{pF}$	-	-	1.0	μs
F_C^1	Chopping Frequency		-	800	-	KHz
B_{OP}	Magnetic Operating Point	At $T_A = 25^{\circ}\text{C}$	5	24	40	Gauss
B_{RP}	Magnetic Release Point	At $T_A = 25^{\circ}\text{C}$	-40	-24	-5	Gauss
B_{HYST}	Hysteresis Window	At $T_A = 25^{\circ}\text{C}$, $ B_{OP} - B_{RP} $	10	48	80	Gauss
B_{SYMOP}	Operate Symmetry	$B_{OPA} - B_{OPB}$	-5	0	5	Gauss
B_{SYMRP}	Release Symmetry	$B_{RPA} - B_{RPB}$	-5	0	5	Gauss
D_{IS}	Distance of Hall elements		0.99	1.00	1.01	mm

1 Guaranteed by device design and characterization.

2 CL = oscilloscope probe capacitance.

Typical Application Circuit

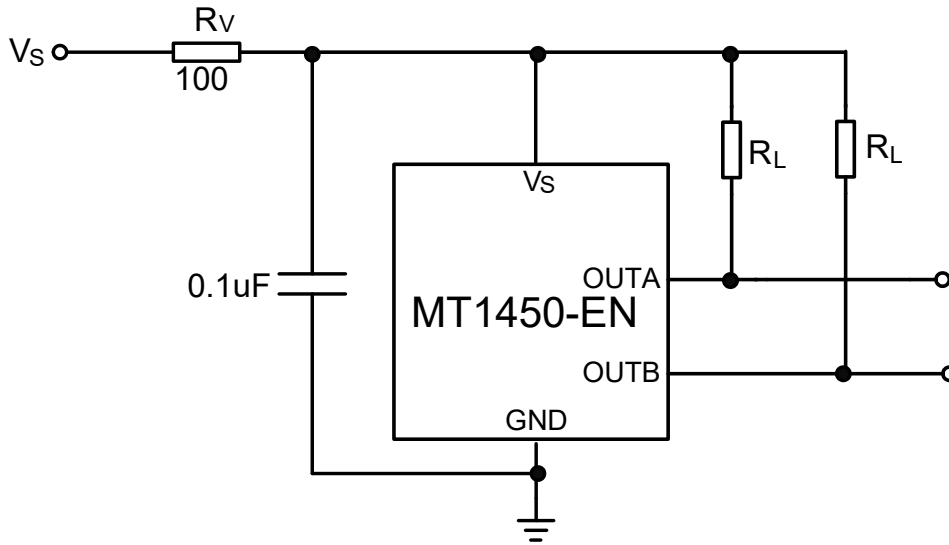

Notes:

- 1) Recommended value for R_L is 1Kohms to 10Kohms.
- 2) Series resistor R_v of 100ohms at V_{DD} is optional. When used, it provides additional protection to the chip against supply surges, but it also increases the minimum operating supply voltage to 3.5V due to IR drop.

Typical Output Waveform

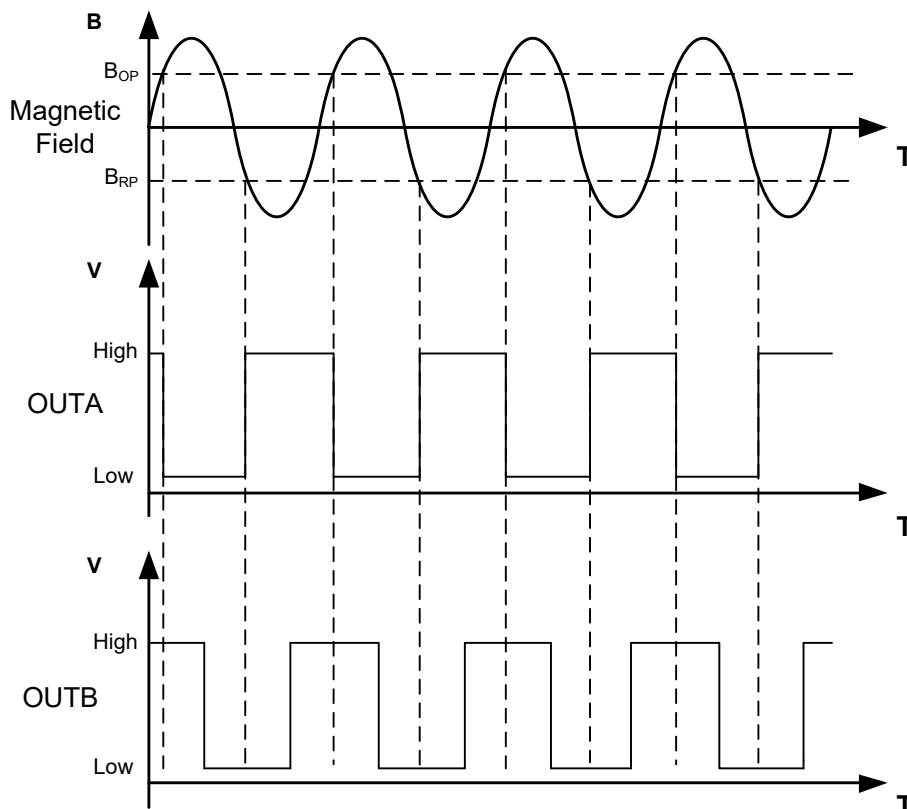

PACKAGE DESIGNATOR (MT1450A-EN) Flat TO-94

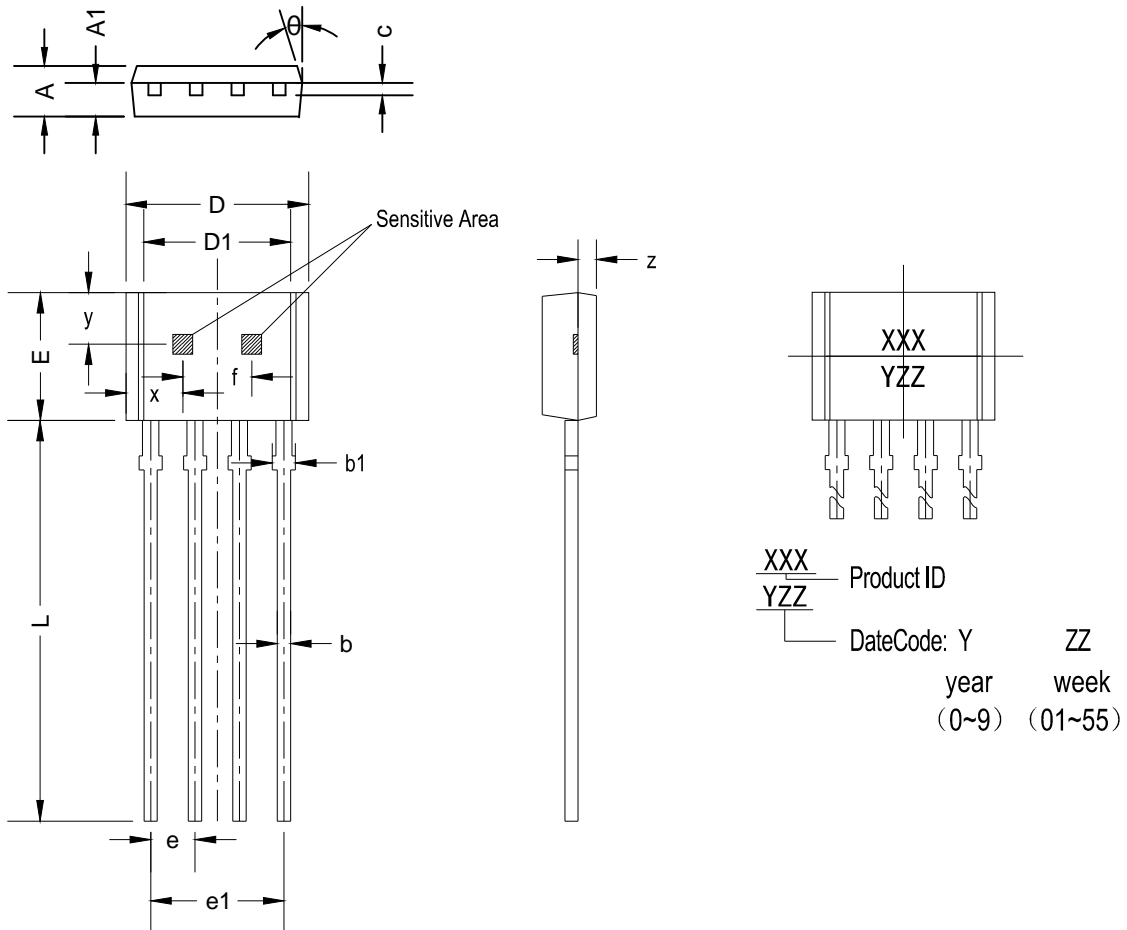

Symbol	Dimensions in Millimeters		Dimensions in Inches	
	Min	Max	Min	Max
A	1.420	1.660	0.056	0.065
A1	0.660	0.860	0.026	0.034
b	0.350	0.480	0.014	0.019
b1	0.400	0.650	0.016	0.026
c	0.360	0.510	0.014	0.020
D	5.100	5.300	0.201	0.208
D1	4.100	4.300	0.161	0.169
E	3.550	3.750	0.140	0.147
e	1.267	1.273	0.050	0.050
e1	3.780	3.840	0.149	0.151
L	13.500	15.500	0.531	0.610
f	0.990	1.010	0.039	0.040
x	1.975	2.175	0.078	0.086
y	1.275	1.475	0.050	0.058
z	0.500TYP		0.020TYP	
θ	10°	12°	10°	12°

PACKAGE DESIGNATOR (MT1450CT-EN) SOP-8

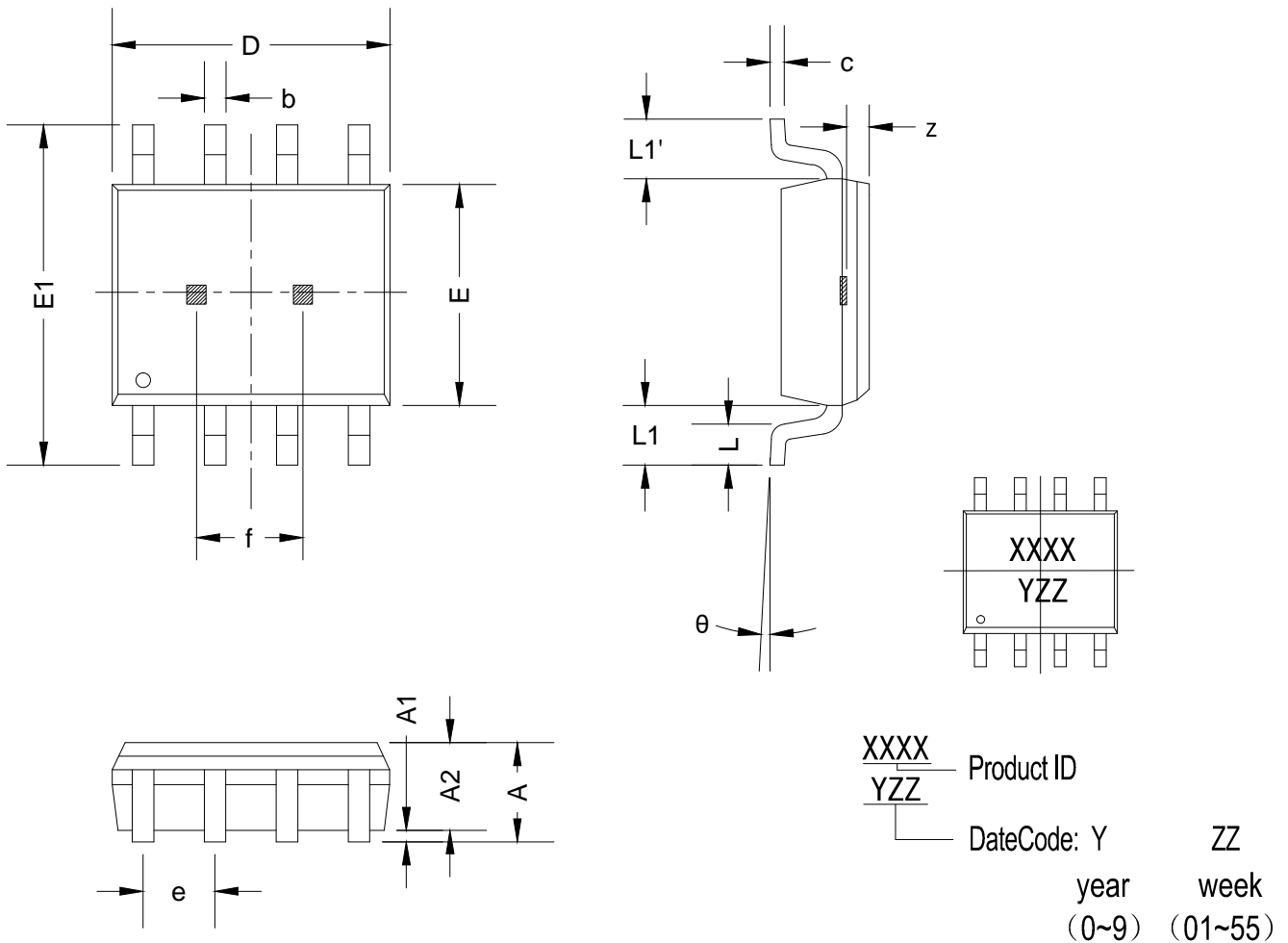

Symbol	Dimensions in Millimeters		Dimensions in Inches	
	Min	Max	Min	Max
A	1.595	1.775	0.063	0.070
A1	0.050	0.150	0.002	0.006
A2	1.350	1.550	0.053	0.061
b	0.375	0.425	0.015	0.017
c	0.170	0.250	0.007	0.010
D	4.700	5.100	0.185	0.200
E	3.875	3.925	0.153	0.155
E1	5.800	6.200	0.228	0.244
e	1.270(BSC)		0.050(BSC)	
L	0.615	0.765	0.024	0.030
L1	1.040REF		0.041REF	
L1-L1'	-	0.120	-	0.005
f	0.990	1.010	0.039	0.040
z	0.500TYP		0.020TYP	
θ	0°	8°	0°	8°

X-ON Electronics

Largest Supplier of Electrical and Electronic Components

Click to view similar products for [Board Mount Hall Effect/Magnetic Sensors](#) category:

Click to view products by [MagnTek](#) manufacturer:

Other Similar products are found below :

[HGPRDT005A](#) [AH277AZ4-AG1](#) [AV-10448](#) [HMC1041Z-TR](#) [SS41C](#) [TLE4917](#) [TLE4946-1L](#) [TLE4976L](#) [SS85CA](#) [BU52002GUL-E2](#)
[BU52003GUL-E2](#) [AH277AZ4-BG1](#) [TLE49614MXTSA1](#) [AH3376-P-B](#) [TLE4941](#) [AH211Z4-AG1](#) [AH3360-FT4-7](#) [TLE4941-1](#) [AH374-P-A](#)
[AH1913-W-7](#) [AH3373-P-B](#) [TLE9852QXXUMA1](#) [MA732GQ-Z](#) [MA330GQ-Z](#) [S-57K1NBL2A-M3T2U](#) [S-57P1NBL9S-M3T4U](#) [S-](#)
[576ZNL2B-L3T2U](#) [S-576ZNL2B-A6T8U](#) [S-57P1NBL0S-M3T4U](#) [S-57A1NSL1A-M3T2U](#) [S-57K1RBL1A-M3T2U](#) [S-57P1NBH9S-M3T4U](#)
[S-57P1NBH0S-M3T4U](#) [S-57A1NSH1A-M3T2U](#) [S-57A1NSH2A-M3T2U](#) [S-57K1NBH1A-M3T2U](#) [S-57A1NNL1A-M3T2U](#) [S-5701BC10B-](#)
[L3T2U5](#) [S-5701BC11B-L3T2U5](#) [S-57GNNL3S-A6T8U](#) [S-57TZ1L1S-A6T8U](#) [S-57GSNL3S-A6T8U](#) [S-5716ANDH0-I4T1U](#) [S-57GSNL5S-](#)
[L3T2U](#) [S-57GDNL3S-L3T2U](#) [S-57GNNL3S-L3T2U](#) [S-57RBNL8S-L3T2U](#) [S-57RBNL9S-A6T8U](#) [S-57RB1L8S-L3T2U](#) [S-57GDNL5S-](#)
[L3T2U](#)