

## Features and Benefits

- **AEC-Q100 automotive qualified**
- **BCD Technology**
- **Magnetic Switch Type: Latch**
- **Wide Operating Voltage Range:**  
Supply Voltage 2.8~24V
- **Specified Operating Temperature Range:**-40°C~150°C
- **High Magnetic Sensitivity**  
 $B_{OP}=24\text{Gauss}$ ,  $B_{RP}=-24\text{Gauss}$  (typical)
- **High ESD Rating**
- **Reversed Power Supply Protection**
- **Over Current Protection**
- **RoHS Compliant**  
2011/65/EU

## Applications

- Automotive, Home appliances, Industrial
- DC Fan, Electric tools
- Magnetic Encoder
- Water Flow Sensor

## Family Members

Part number	Description
MT3401A-EN	Flat TO-92 package, bulk packaging (1000pcs/bag)
MT3401A-T-EN	Flat TO-92 package, radial lead, bulk packaging (1000pcs/bag)
MT3401AT-EN	SOT-23 package, tape and reel packaging (3000pcs/bag)
MT3401BT-EN	SOT-89B package, tape and reel packaging (1000pcs/bag)
MT3401ET-EN	SOT-23(thin outline)package, tape and reel packaging (3000pcs/bag)

## General Description

The MT3401-EN is a family of latch-type Hall-effect sensor ICs produced in BCD technology, which offers both high performance and high reliability. The IC internally includes a voltage regulator for operation with supply voltage from 2.8V to 24V, a small-signal amplifier, Hall sensors with dynamic offset cancellation, a Schmitt trigger and an open-drain output with over-current protection. It features temperature compensation technique to make the magnetic switching points stable over a wide temperature range. Other key features such as reverse supply voltage protection, output over-current protection and ESD level exceeding  $\pm 6\text{KV}$  (HBM) make the IC extremely robust and fault tolerant, which is important in demanding application environment such as automotive. Its extremely low operating supply voltage 2.8V also makes it possible to add external resistance in series with the supply pin for even greater protection against high voltage transients from the power supply.

The Hall-effect IC is designed to respond to alternating North and South poles. When the magnetic flux density (B) is greater than the operate point ( $B_{OP}$ ), the output turns on (Low). The output is held steady till the magnetic flux density (B) is less than the release point ( $B_{RP}$ ), at which point it turns off (High).

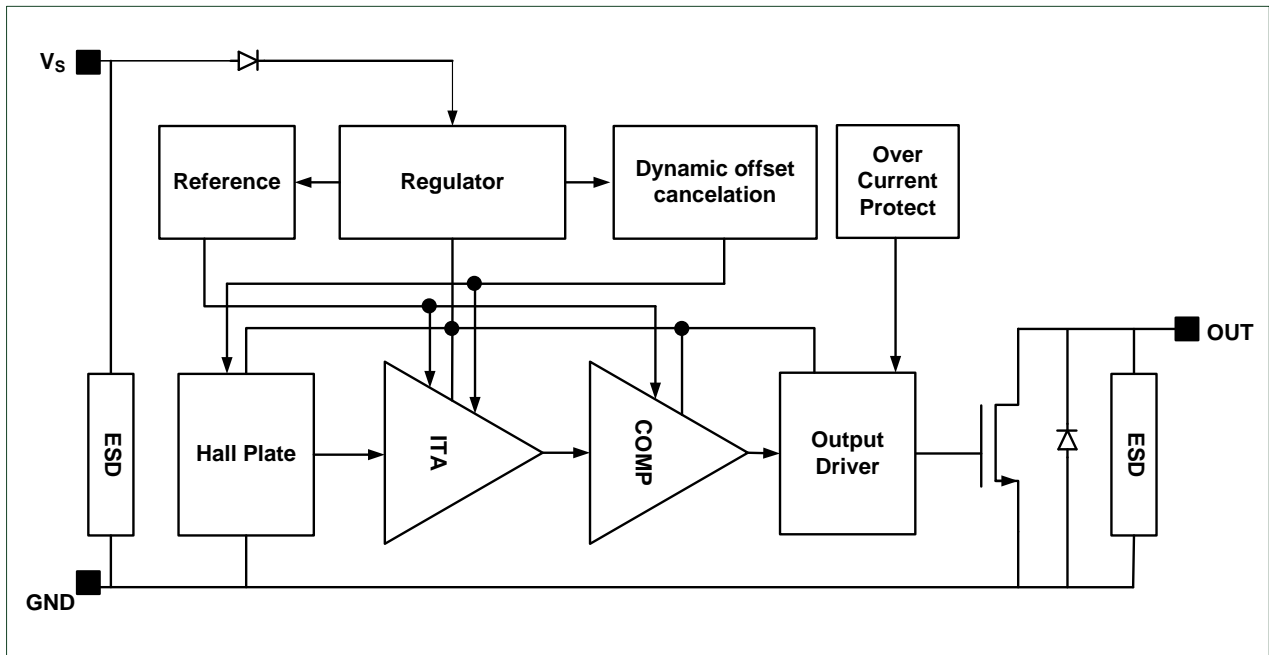

**Functional Block Diagram**

## Function Description

### Definition of Magnetic Parameters

$B_{OP}$ : Operating Point, magnetic flux density applied on the branded side of the package which turns the output driver ON ( $V_{OUT}=Low$ )

$B_{RP}$ : Release Point, magnetic flux density applied on the branded side of the package which turns the output driver OFF ( $V_{OUT}=High$ )

$B_{HYST}$ : Hysteresis Window,  $|B_{OP}-B_{RP}|$

### Definition of Switching Function

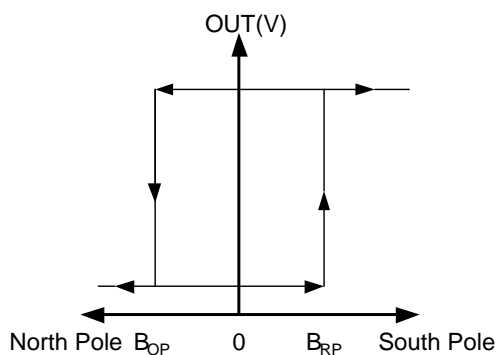

Switching Behavior of AT

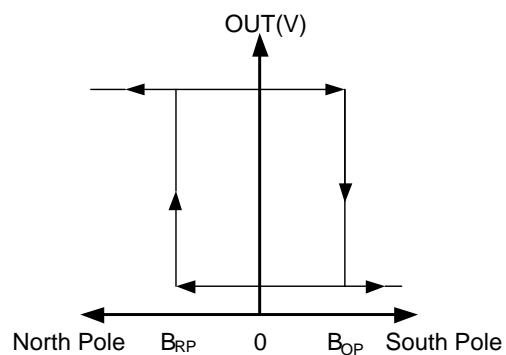

Switching Behavior of A, BT and ET

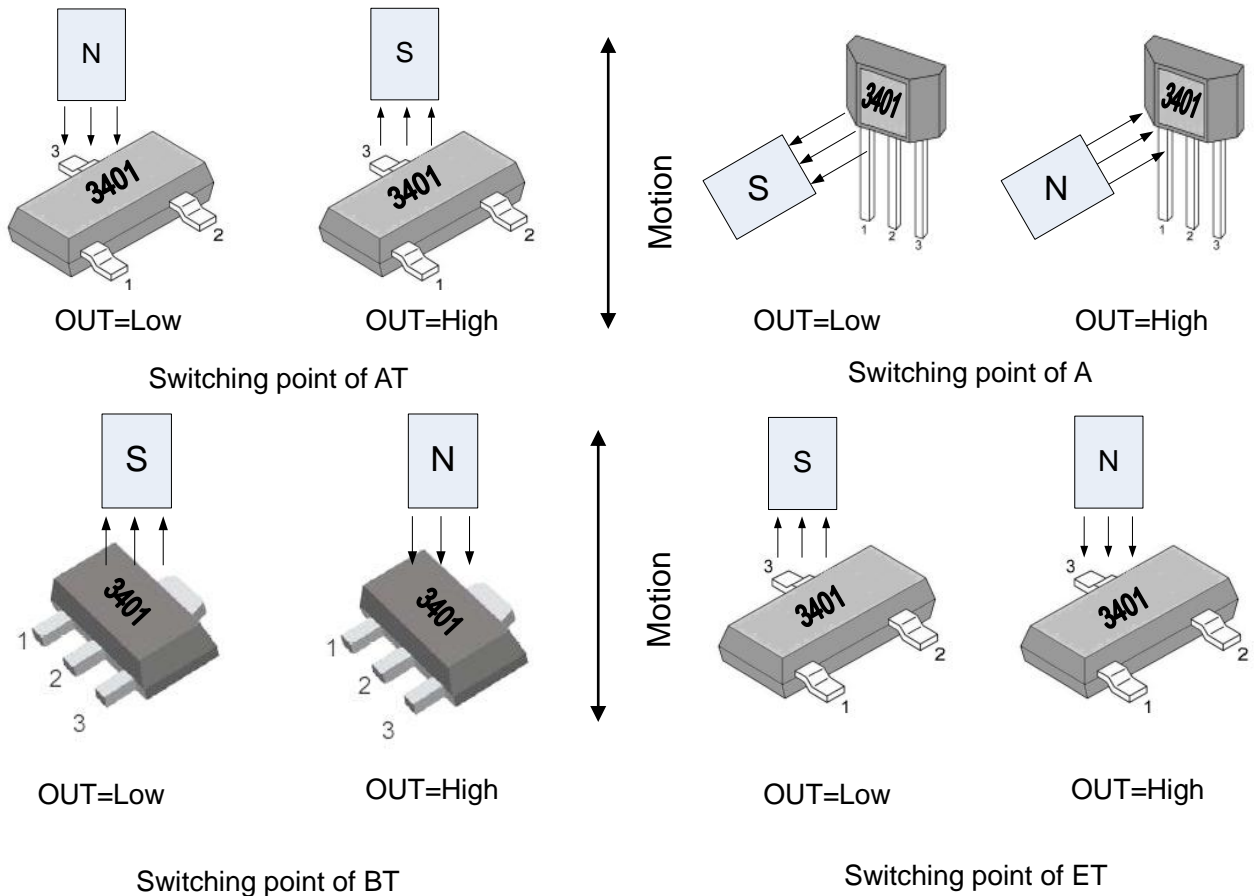

Note: Direction of magnetic flux

## Pin Description

MT3401AT-EN

Name	Number	Description
V <sub>s</sub>	1	Power
GND	3	Ground
OUT	2	Open-drain Output

MT3401A -EN(MT3401A-T-EN)

Name	Number	Description
V <sub>s</sub>	1	Power
GND	2	Ground
OUT	3	Open-drain Output

MT3401BT-EN

Name	Number	Description
V <sub>s</sub>	1	Power
GND	2	Ground
OUT	3	Open-drain Output

MT3401ET-EN

Name	Number	Description
V <sub>s</sub>	1	Power
GND	3	Ground
OUT	2	Open-drain Output

## Electrical and Magnetic Characteristics

### Absolute Maximum Ratings

Absolute maximum ratings are limiting values to be applied individually, and beyond which the serviceability of the circuit may be impaired. Functional operability is not necessarily implied. Exposure to absolute maximum rating conditions for an extended period of time may affect device reliability.

Absolute maximum ratings: all voltages listed are referenced to GND.

Symbol	Parameters	Min	Max	Units
$V_S$	Supply Voltage	-	27	V
$V_{RCC}$	Reverse Battery Voltage	-27	-	V
$V_{OUT}$	Output Voltage	-	27	V
$I_{OUT}$	Continuous output current	-	50	mA
$T_A$	Operating ambient Temperature	-40	150	°C
$T_S$	Storage temperature	-50	150	°C
$T_J$	Junction Temperature	-	165	°C
B	Magnetic Flux	No Limit		Gauss

### Power derating Curve

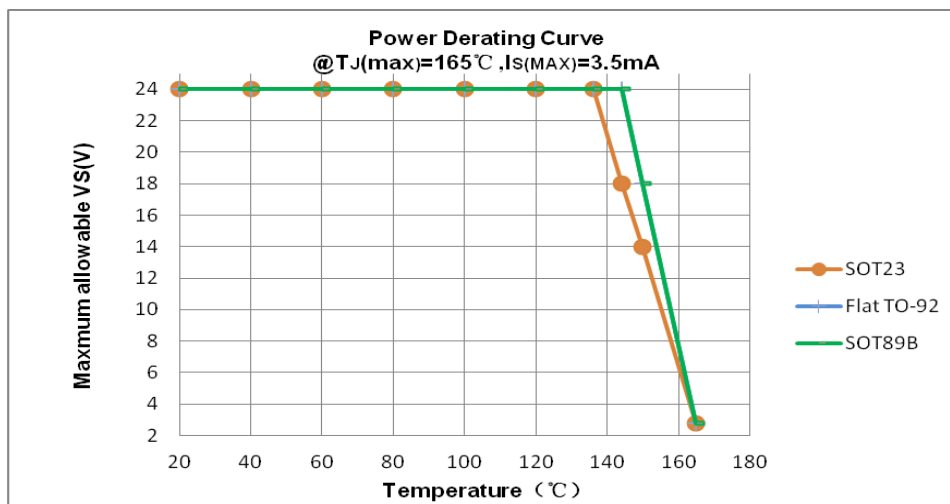

## MT3401-EN Series Specifications

At  $T_A = -40$  to  $150^\circ\text{C}$ ,  $V_S = 2.8\text{V}$  to  $24\text{V}$  (unless otherwise specified)

Symbol	Parameter	Test Condition	Min	Typ	Max	Units
$V_S$	Supply Voltage	Operating	2.8	-	24	V
$I_S$	Supply Current	$B < B_{RP}$	1	2.3	3.5	mA
$I_{OCP}$	Short Circuit Protection Current	$B > B_{OP}$ , $V_{OUT} = V_S$	-	50	-	mA
$V_{DSON}$	Output Saturation Voltage	$I_{OUT} = 20\text{mA}$ , $B > B_{OP}$	-	-	0.4	V
$I_{OFF}$	Output Leakage Current	$B < B_{RP}$ , $V_{OUT} = 24\text{V}$	-	-	10	$\mu\text{A}$
$T_R^{1,2}$	Output Rise Time	$R_L = 1\text{K}\Omega$ , $C_L = 20\text{pF}$	-	-	1.0	$\mu\text{s}$
$T_F^{1,2}$	Output Fall Time	$R_L = 1\text{K}\Omega$ , $C_L = 20\text{pF}$	-	-	1.0	$\mu\text{s}$
$T_{PO}^1$	Power On Time	$dV_S/dt > 5\text{V}/\mu\text{s}$ , $B > B_{OP(MAX)}$	-	-	10	$\mu\text{s}$
$F_C^1$	Chopping Frequency		-	800	-	KHz
$R_{TH}$	SOT-23 Package Thermal Resistance		-	301	-	$^\circ\text{C}/\text{W}$
	Flat TO-92 Package Thermal Resistance		-	230	-	$^\circ\text{C}/\text{W}$
	SOT-89B Package Thermal Resistance		-	230	-	$^\circ\text{C}/\text{W}$
$B_{OP}$	Magnetic Operating Point	$T_A = 25^\circ\text{C}$	5	24	40	Gauss
$B_{RP}$	Magnetic Release Point	$T_A = 25^\circ\text{C}$	-40	-24	-5	Gauss
$B_{HYST}$	Hysteresis Window	$T_A = 25^\circ\text{C}$ , $ B_{OP} - B_{RP} $	10	48	80	Gauss
ESD	Electrostatic discharge (HBM)	AEC-Q100-002	-	$\pm 6$	-	KV
	Electrostatic discharge (CDM)	AEC-Q100-011	-	$\pm 1$	-	KV

1 Guaranteed by device design and characterization.

2 CL = oscilloscope probe capacitance.

## Characteristic Performance

Average Supply Current versus Supply Voltage

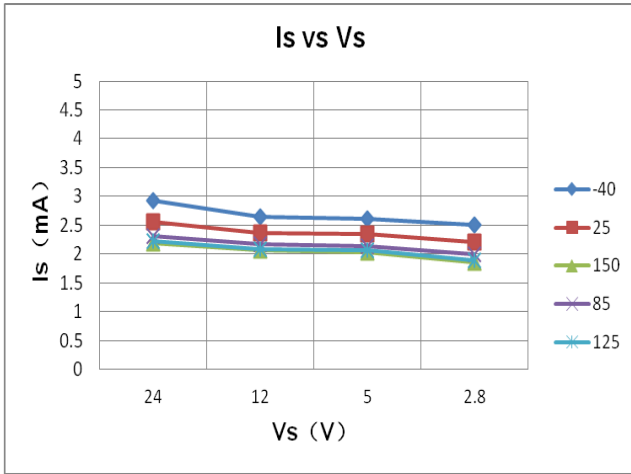

Average Supply Current versus Temperature

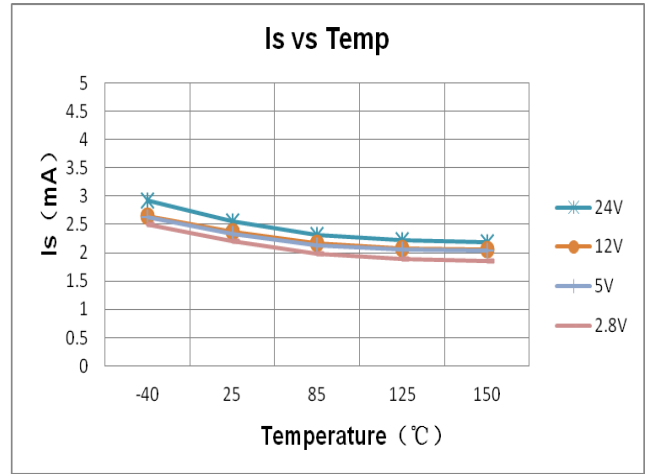

Magnetic Characteristics versus Supply Voltage

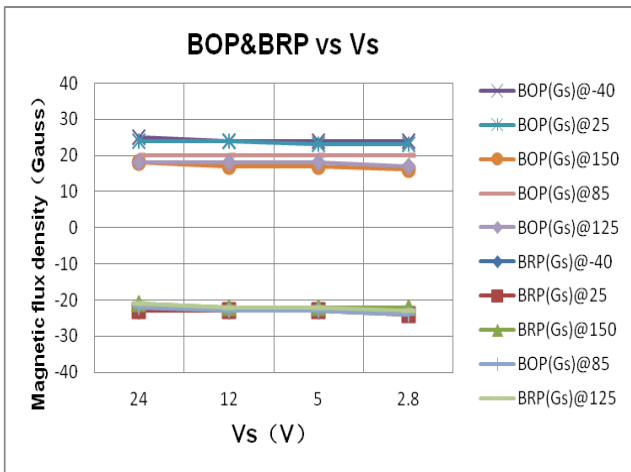

Magnetic Characteristics versus Temperature

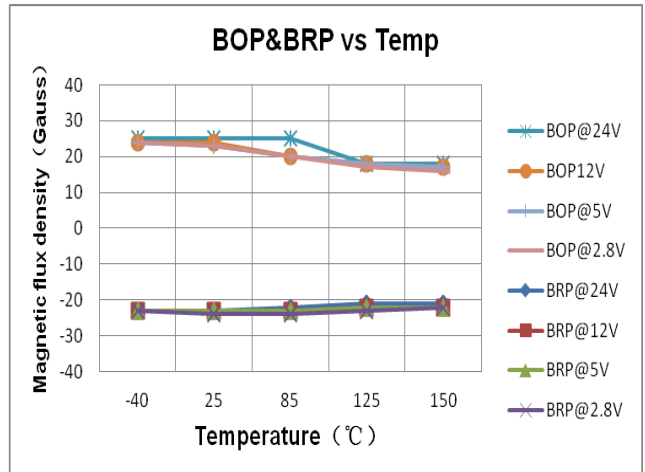

## Typical Application Circuit

Note: Recommended value for  $R_L$  is 1KOhms to 10KOhms.

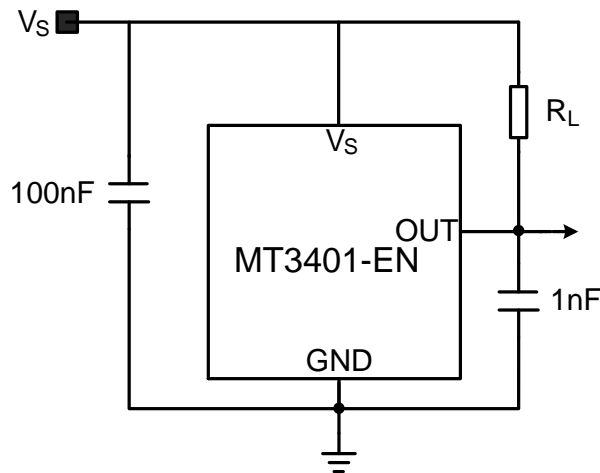

## Typical Output Waveform (The TO-92 package as an example)

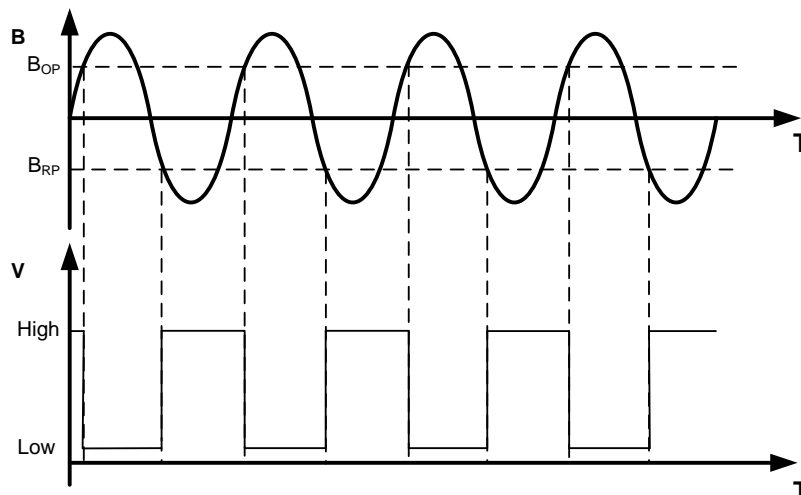

## Power On Output Waveform (The Flat TO-92 package as an example)

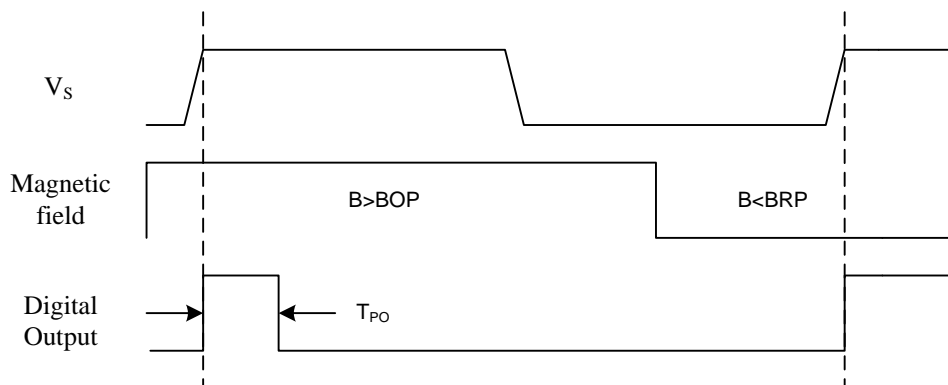

Note:  $V_s$  rise time  $< 1\mu s$ ,  $T_{PO}$  is the time from  $V_s$  becoming stable to output becoming valid.

### PACKAGE DESIGNATOR (MT3401A-EN) Flat TO-92

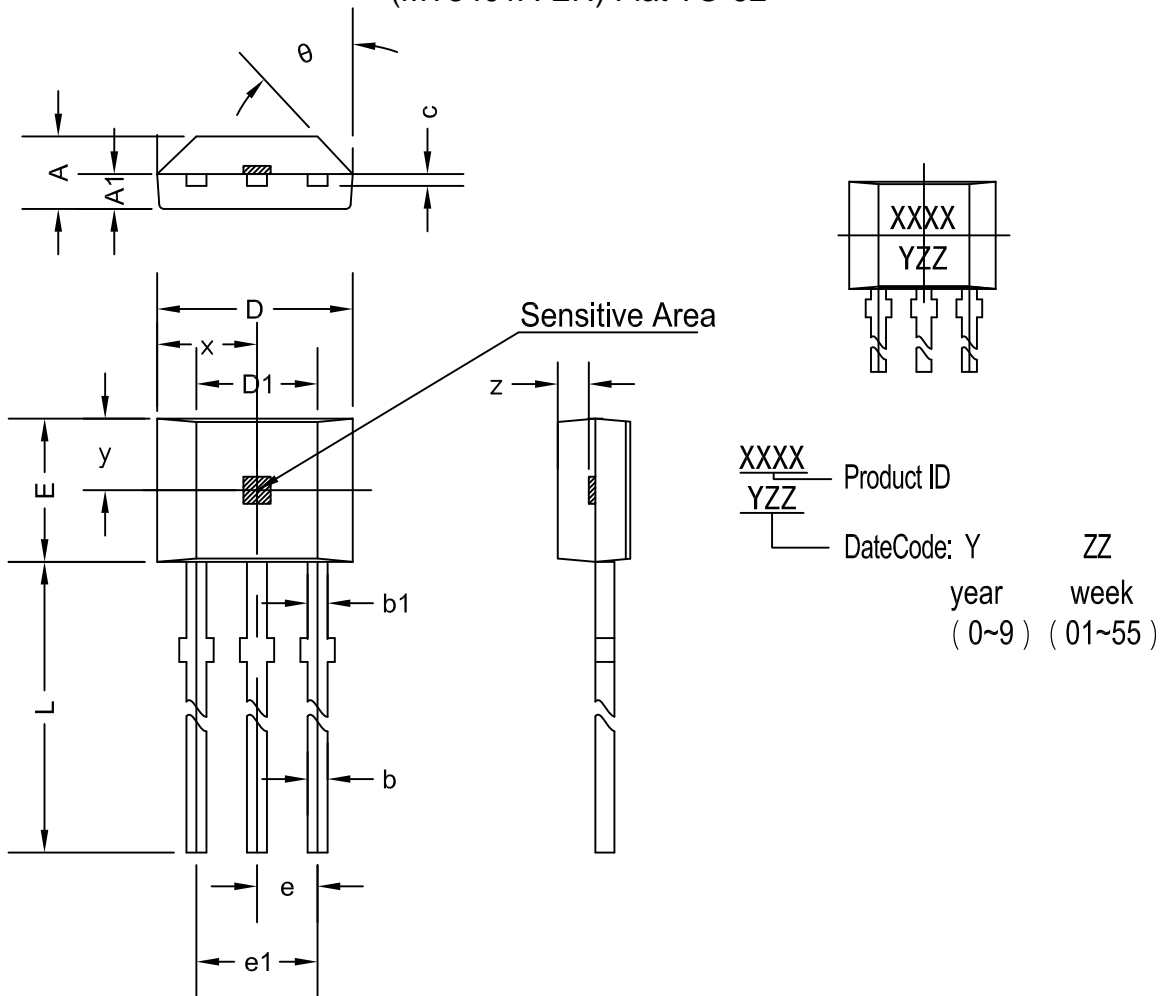

Symbol	Dimensions in Millimeters		Dimensions in Inches	
	Min	Max	Min	Max
A	1.420	1.670	0.056	0.066
A1	0.660	0.860	0.026	0.034
b	0.350	0.560	0.014	0.022
b1	0.400	0.550	0.016	0.022
C	0.360	0.510	0.014	0.020
D	3.900	4.200	0.154	0.165
D1	2.970	3.270	0.117	0.129
E	2.900	3.280	0.114	0.129
e	1.270 TYP		0.050 TYP	
e1	2.440	2.640	0.096	0.104
L	13.500	15.500	0.531	0.610
x	2.025TYP		0.080TYP	
y	1.545TYP		0.061TYP	
z	0.500TYP		0.020TYP	
θ	45°TYP		45°TYP	



## PACKAGE DESIGNATOR (MT3401A-T-EN) Flat TO-92 Radial Lead

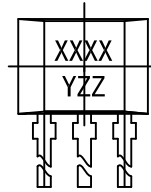
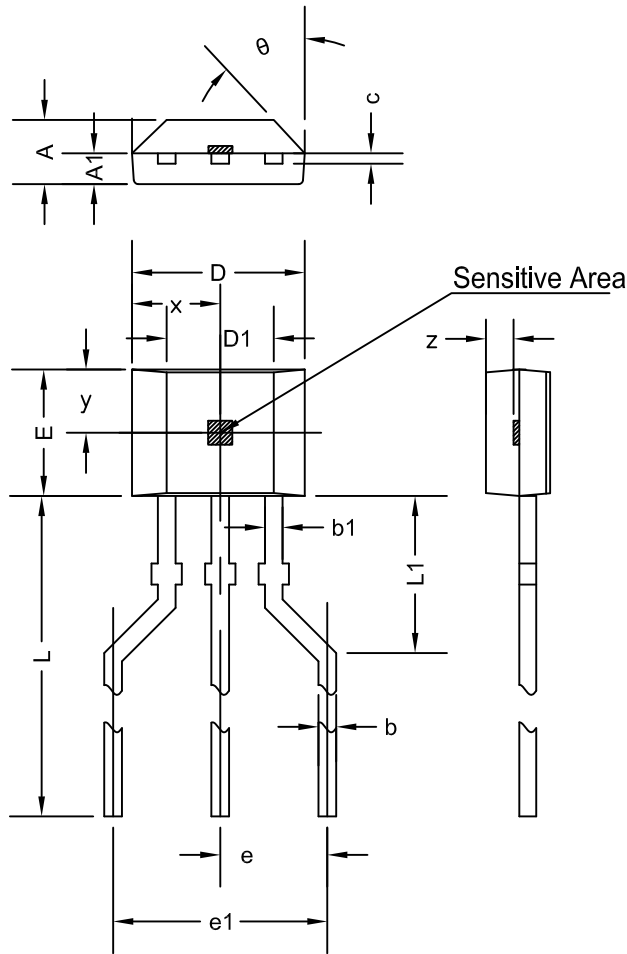

XXXX Product ID  
 YYZ DateCode: Y ZZ  
 year week  
 (0~9) (01~55)

Symbol	Dimensions in Millimeters		Dimensions in Inches	
	Min	Max	Min	Max
A	1.420	1.670	0.056	0.066
A1	0.660	0.860	0.026	0.034
b	0.350	0.560	0.014	0.022
b1	0.400	0.550	0.016	0.022
c	0.360	0.510	0.014	0.020
D	3.900	4.200	0.154	0.165
D1	2.970	3.270	0.117	0.129
E	2.900	3.280	0.114	0.129
e	2.540TYP		0.100TYP	
e1	5.080TYP		0.200TYP	
L	14.300REF		0.563REF	
L1	2.150REF		0.085REF	
x	2.025TYP		0.080TYP	
y	1.545TYP		0.061TYP	
z	0.500TYP		0.020TYP	
θ	45°TYP		45°TYP	

### PACKAGE DESIGNATOR (MT3401AT-EN) SOT-23

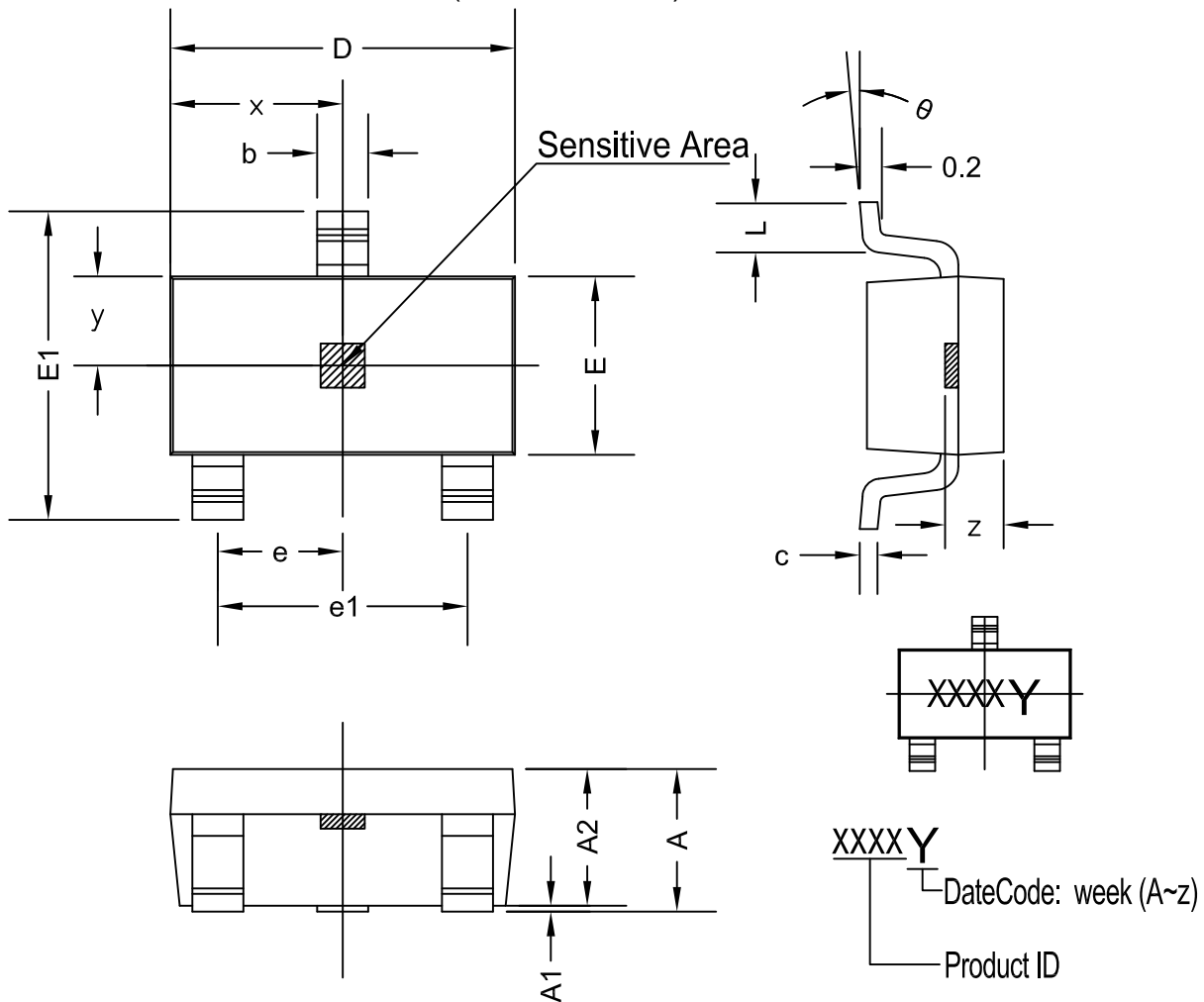

Symbol	Dimensions in Millimeters		Dimensions in Inches	
	Min	Max	Min	Max
A	1.050	1.250	0.041	0.049
A1	0.000	0.100	0.000	0.004
A2	1.050	1.150	0.041	0.045
b	0.300	0.500	0.012	0.020
c	0.100	0.200	0.004	0.008
D	2.820	3.020	0.111	0.119
E	1.500	1.700	0.059	0.067
E1	2.650	2.950	0.104	0.116
e	0.950 TYP		0.037 TYP	
e1	1.800	2.000	0.071	0.079
L	0.300	0.600	0.012	0.024
x	1.460TYP		0.057TYP	
y	0.800TYP		0.032TYP	
z	0.600TYP		0.024TYP	
θ	0°	8°	0°	8°

# MT3401-EN Series

BCD, Latch, Hall-Effect Magnetic Position Sensors



## PACKAGE DESIGNATOR (MT3401BT-EN) SOT-89B

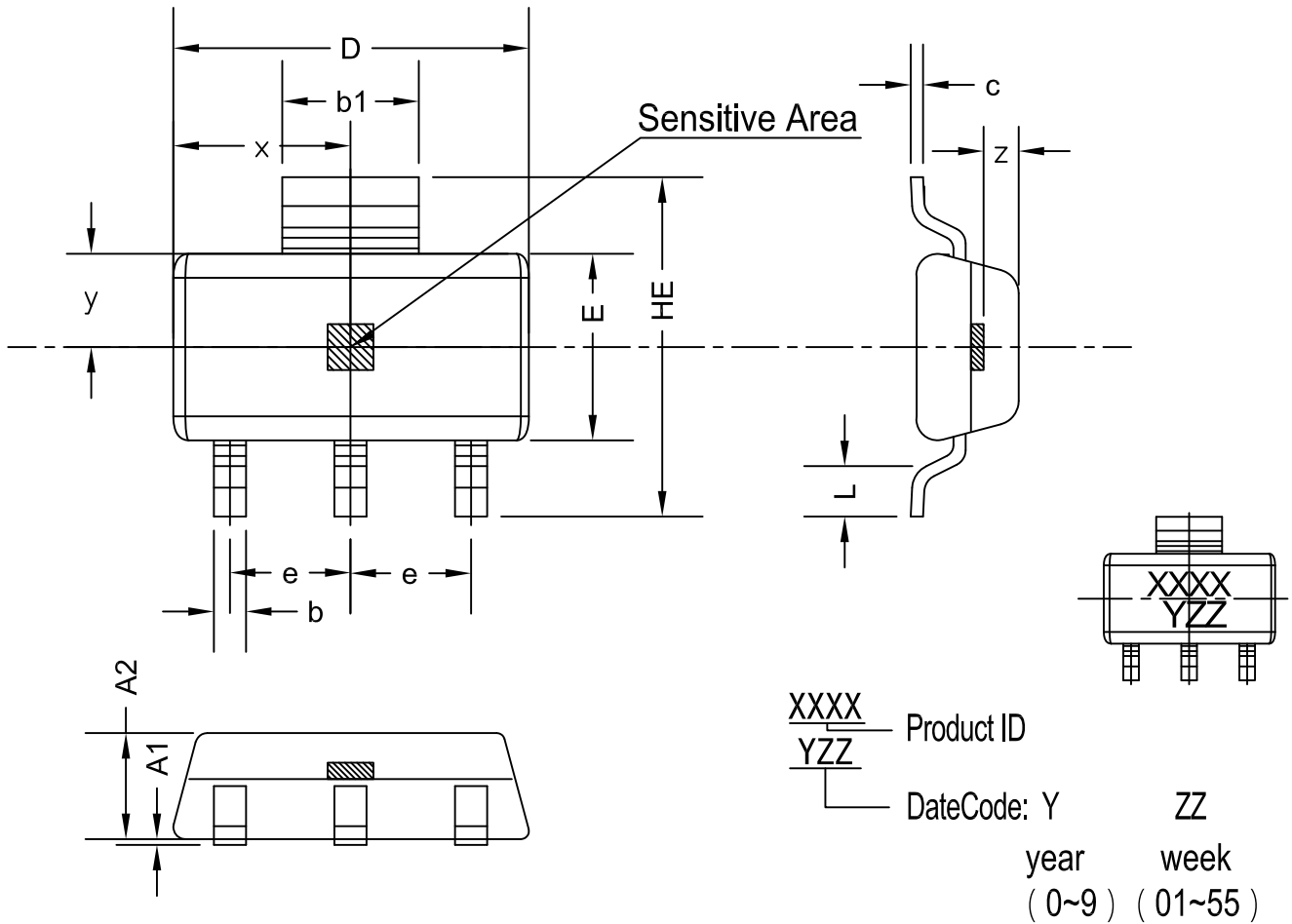

Symbol	Dimensions in Millimeters		Dimensions in Inches	
	Min	Max	Min	Max
A1	0.000	0.100	0.000	0.004
A2	1.220	1.420	0.048	0.056
b	0.300	0.500	0.012	0.020
b1	1.600	1.800	0.063	0.070
D	4.400	4.600	0.173	0.181
c	1.152 REF		0.045 REF	
E	2.400	2.600	0.094	0.102
HE	4.000	4.400	0.157	0.173
e	1.500 TYP		0.060 TYP	
L	0.350	0.550	0.014	0.022
x	2.250TYP		0.089TYP	
y	1.250TYP		0.049TYP	
z	0.300TYP		0.012TYP	

**PACKAGE DESIGNATOR**  
(MT3401ET-EN) SOT-23 (thin outline)

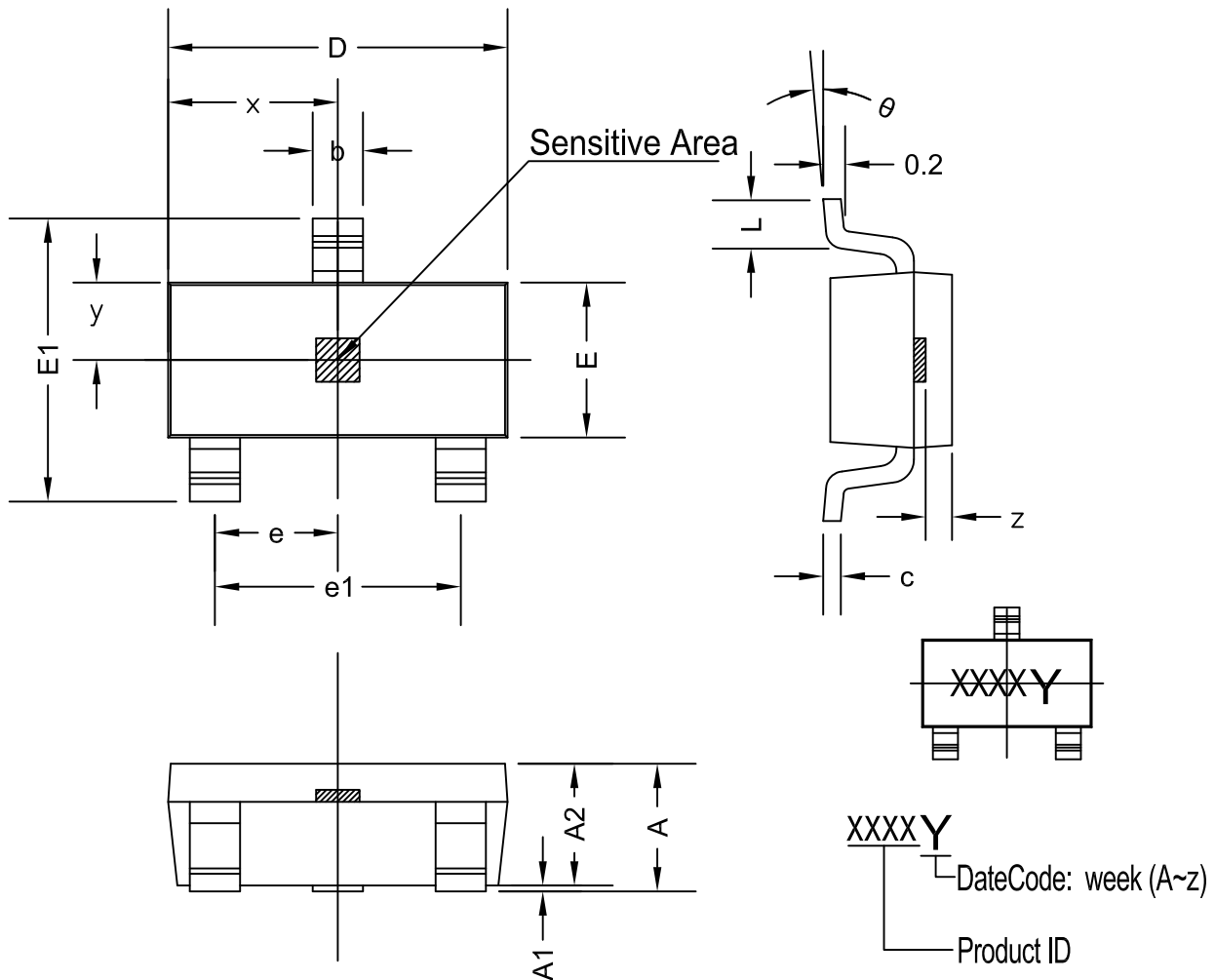

Symbol	Dimensions in Millimeters		Dimensions in Inches	
	Min	Max	Min	Max
A	0.900	1.150	0.035	0.045
A1	0.000	0.100	0.000	0.004
A2	0.900	1.050	0.035	0.041
b	0.300	0.500	0.012	0.020
c	0.080	0.150	0.003	0.006
D	2.800	3.000	0.110	0.118
E	1.200	1.400	0.047	0.055
E1	2.250	2.550	0.089	0.100
e	0.950 TYP		0.037 TYP	
e1	1.800	2.000	0.071	0.079
L	0.550REF		0.022REF	
x	1.460TYP		0.057TYP	
y	0.650TYP		0.026 TYP	
z	0.500TYP		0.020TYP	
θ	0°	8°	0°	8°

## X-ON Electronics

Largest Supplier of Electrical and Electronic Components

*Click to view similar products for [Board Mount Hall Effect/Magnetic Sensors](#) category:*

*Click to view products by [MagnTek](#) manufacturer:*

Other Similar products are found below :

[HGPRDT005A](#) [AH277AZ4-AG1](#) [AV-10448](#) [HMC1041Z-TR](#) [SS41C](#) [TLE4917](#) [TLE4946-1L](#) [50017859-003](#) [TY-13101](#) [TLE4976L](#)  
[SS85CA](#) [BU52002GUL-E2](#) [BU52003GUL-E2](#) [AH277AZ4-BG1](#) [TLE49614MXTSA1](#) [AH3376-P-B](#) [TLE4941](#) [AH211Z4-AG1](#) [AH3360-](#)  
[FT4-7](#) [TLE4941-1](#) [AH374-P-A](#) [SS460P-T2](#) [AH1913-W-7](#) [AH3373-P-B](#) [TLE9852QXXUMA1](#) [MA732GQ-Z](#) [MA330GQ-Z](#) [S-57K1NBL2A-](#)  
[M3T2U](#) [S-57P1NBL9S-M3T4U](#) [S-576ZNL2B-L3T2U](#) [S-576ZNL2B-A6T8U](#) [S-57P1NBL0S-M3T4U](#) [S-57A1NSL1A-M3T2U](#) [S-](#)  
[57K1RBL1A-M3T2U](#) [S-57P1NBH9S-M3T4U](#) [S-57P1NBH0S-M3T4U](#) [S-57A1NSH1A-M3T2U](#) [S-57A1NSH2A-M3T2U](#) [S-57K1NBH1A-](#)  
[M3T2U](#) [S-57A1NNL1A-M3T2U](#) [S-5701BC10B-L3T2U5](#) [S-5701BC11B-L3T2U5](#) [S-57GNNL3S-A6T8U](#) [S-57TZ1L1S-A6T8U](#) [S-](#)  
[57GSNL3S-A6T8U](#) [S-5716ANDH0-I4T1U](#) [S-57GSNL5S-L3T2U](#) [S-57GDNL3S-L3T2U](#) [S-57GNNL3S-L3T2U](#) [S-57RBNL8S-L3T2U](#)