

Latch, High Voltage Hall-Effect Switch IC

1 Product Description

The MT4401-EN family is produced by BCD technology with both high performance and high reliability. The Hall IC internally includes an on-chip Hall voltage generator, a voltage regulator for operation with supply voltage of 3.8V to 60V, temperature compensation circuitry, small-signal amplifier, Hall IC with dynamic offset cancellation system, Schmitt trigger and an open collector output. It also includes a clamp diode at output and reversed power supply protection enhances the robustness of Hall IC.

The Hall IC designed to respond to alternating north and south poles. While the magnetic flux density(B) is larger than operating point (BOP), the output will be turned on (Low), the output is held until the magnetic flux density(B) is lower than releasing point (BRP), then turn off (High).

The MT4401-EN family provides a variety of packages to customers: SOT-23/SOT-89B for surface mount and flat TO-92 for through-hole mount. All packages are RoHS compliant.

2 Feature

- BCD Technology
- Latch Switch
- 3.8~60V Operating Vcc Range
- -40°C~150°C Operating Temperature
- Package Option:
 - Flat TO-92
 - SOT-23
 - SOT89B
- Magnetic Sensitivity Option:
 - BOP=50Gs, BRP=-50Gs
- Open-Drain Output
- -24V Reversed Power Supply Protection
- Output Limiting Current Protection
- RoHS Compliant: (EU)2015/863

3 Product Overview of MT4401-EN

Part No.	Description
MT4401A-EN	Flat TO-92, bulk packaging (1000pcs/bag)
MT4401AT-EN	SOT-23, tape & reel (3000pcs/bag)
MT4401BT-EN	SOT-89B, tape & reel (1000pcs/bag)

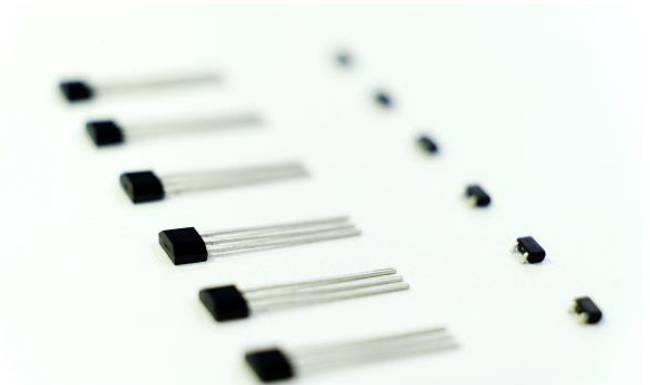

4 Applications

- Automotive, Home appliances,
- Industrial
- Speed Detection
- Magnetic Encoder
- Brushless DC Motor Communication

5. Pin Configuration and Functions

	Vcc	Out	GND
SOT-23	1	2	3
SOT-89B	1	3	2
Flat TO-92	1	3	2
Description	Power	Output Open-Drain	Ground

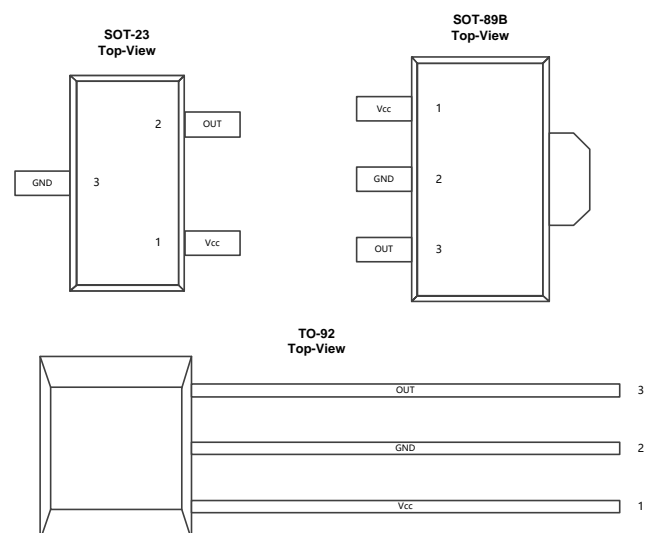

Figure.1 Pin Configuration & Functions

Table of Contents

1	Product Description.....	1
2	Feature.....	1
3	Product Overview of MT4401-EN	1
4	Applications.....	1
5	Pin Configuration and Functions.....	1
6	Definition of Switching Function.....	3
7	Functional Description.....	3
8	Feature Description.....	3
9	Functional Block Diagram.....	4
10	Electrical and Magnetic Characteristics.....	4
	10.1 Absolute Maximum Ratings.....	4
	10.2 Electrical Specifications.....	5
	10.3 Magnetic Characteristics.....	5
	10.4 ESD Ratings.....	5
	10.5 Characteristic Performance.....	6
	10.6 Typical Output Waveform.....	7
11	Typical Application Circuit.....	7
12	Package Material Information.....	8
	12.1 SOT-23 Package Information.....	8
	12.2 SOT-89B Package Information.....	9
	12.3 Flat TO-92 Package Information.....	10

Reversion History

1	Originally Version	
2	1.1 Version	Tighten Bop & Brp spec
3	1.2 Version	Update RoHS compliant to (EU)2015/863

6 Definition of Switching Function

Figure.2 & Figure.3 shows the device functionality and hysteresis

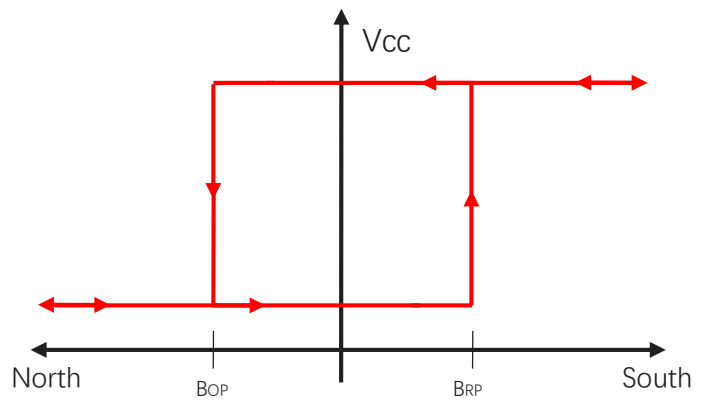
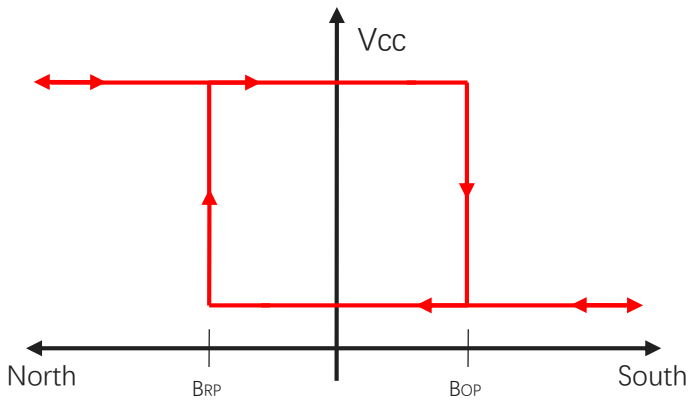

Figure.2 Switching Function of Flat TO-92 & SOT-89B

Figure.3 Switching Function of SOT-23

7 Function Description

B_{OP}: Operating Point, Magnetic flux density applied on the branded side of the package which turns the output driver ON ($V_{OUT}=Low$)

B_{RP}: Releasing Point, Magnetic flux density applied on the branded side of the package which turns the output driver OFF ($V_{OUT}=High$)

B_{HYST}: Hysteresis Window, $|B_{OP} - B_{RP}|$

Devices that have a lower magnetic threshold ($V_{OUT}=High$) detect magnets at a farther distance. Higher thresholds ($V_{OUT}=Low$) generally require a closer distance or larger magnet.

8 Feature Description

The MT4401-EN device is sensitive to the magnetic field component that is perpendicular to the top of the package

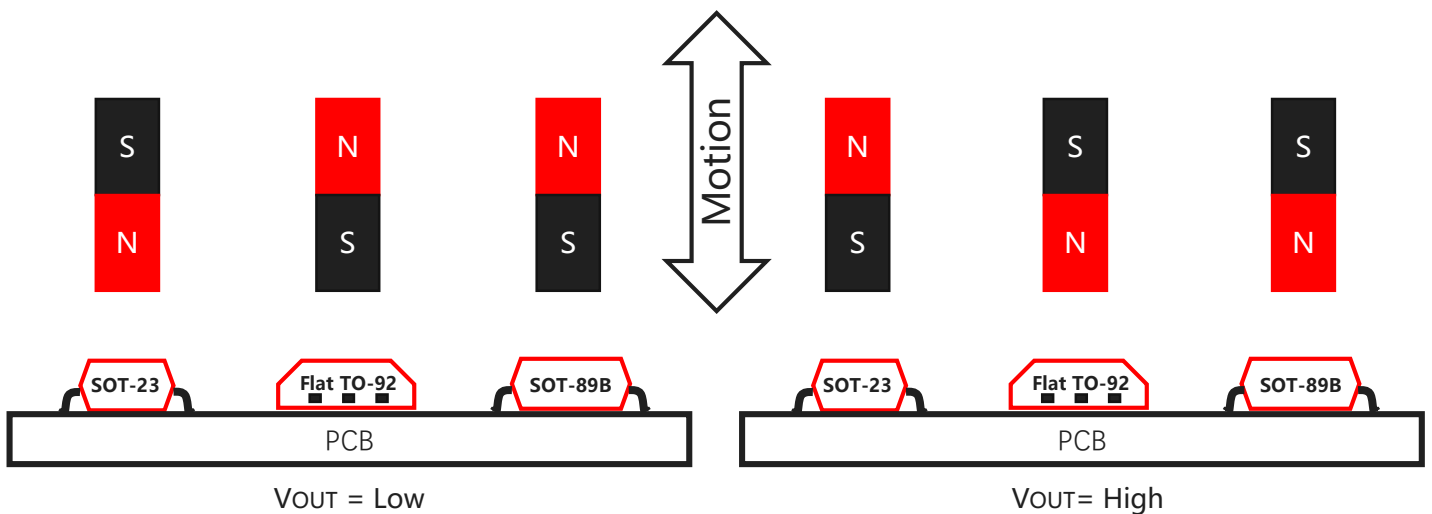

Figure.4 Flux Direction Polarity

9 Functional Block Diagram

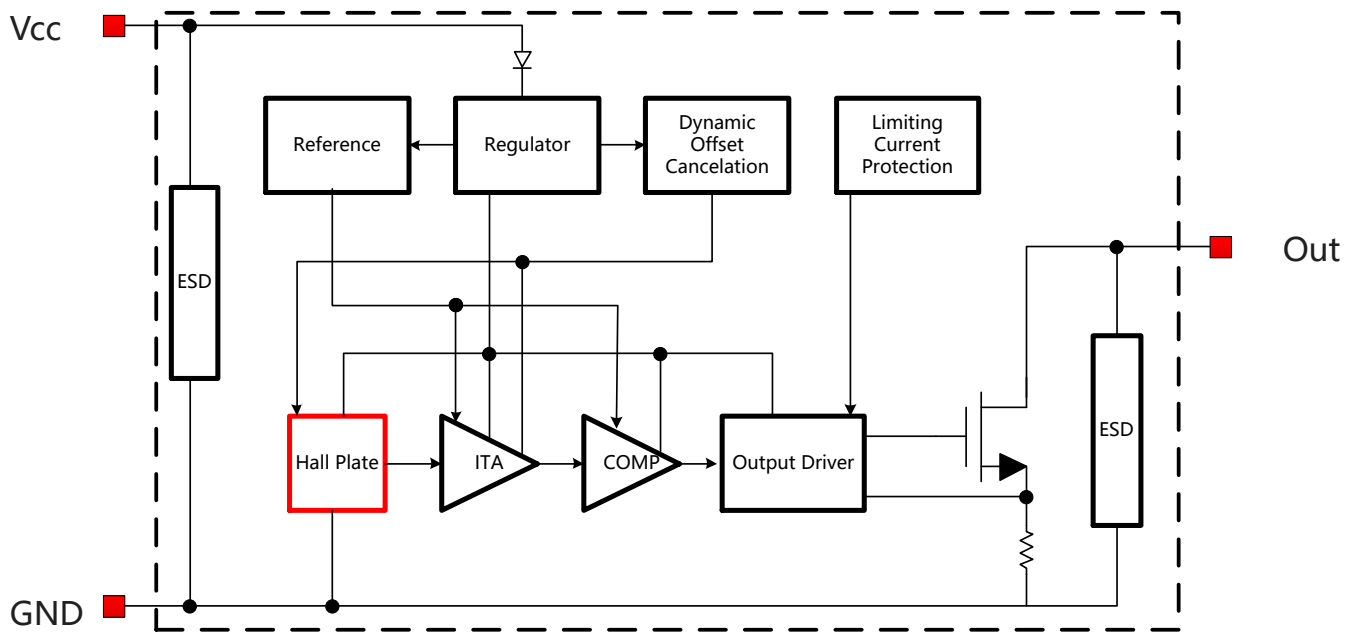

Figure.5 Functional Block Diagram

10 Electrical and Magnetic Characteristics

10.1 Absolute Maximum Ratings

Absolute maximum ratings are limited values to be applied individually, and beyond which the serviceability of the circuit may be impaired. Functional operability is not necessarily implied. Exposure to absolute maximum rating conditions for an extended period of time may affect device reliability.

Symbol	Parameters	Min	Max	Units
V _{CC}	Supply Voltage	-	65	V
V _{RCC}	Reverse Battery Voltage	-24	-	V
V _{OUT}	Output Voltage	-	65	V
I _{OUT}	Continuous Output Current	-	50	mA
T _A	Operating Ambient Temperature	-40	150	°C
T _S	Storage Temperature	-50	150	°C
T _J	Junction Temperature	-	165	°C
B	Magnetic Flux Density	No Limit		Gs

10.2 Electrical Specifications

At $T_A = -40 \sim 150\text{ }^\circ\text{C}$, $V_{CC} = 3.8\text{V} \sim 60\text{V}$ (unless otherwise specified)

Symbol	Parameters	Test Condition	Min	Typ	Max	Unit
V _{CC}	Supply Voltage	Operating	3.8	-	60	V
I _{CC}	Supply Current	B < B _{RP}	-	4	6	mA
I _{OCP}	Short Circuit Protection Current	B > B _{OP} , V _{OUT} = V _{CC}	-	50	-	mA
V _{DSON}	Output Saturation Voltage	I _{OUT} = 20mA, B > B _{OP}	-	-	0.4	V
I _{OFF}	Output Leakage Current	V _{OUT} = 60V	-	-	10	uA
T _R	Output Rise Time	R _L = 1KOhm, C _L = 20pF	-	-	1.0	us
T _F	Output Fall Time	R _L = 1KOhm, C _L = 20pF	-	-	1.0	us
T _{PO}	Power on Time	dV _{CC} /dt > 5V/uS B > B _{OP(MAX)}	-	-	10	us
F _C	Chopping Frequency		-	800	-	KHz
F _S	Sampling Frequency		-	200	-	KHz
R _{TH}	Thermal Resistance of SOT-23		-	301	-	°C/W
	Thermal Resistance of Flat TO-92		-	230	-	°C/W
	Thermal Resistance of SOT-89B		-	230	-	°C/W

10.3 Magnetic Characteristics

At $V_{CC} = 3.8\text{V} \sim 60\text{V}$ (unless otherwise specified)

Part No.	Symbol	Min	Typ	Max	Unit
MT4401-EN Series	B _{OP} , T _A = 25°C	35	50	65	Gs
	B _{RP} , T _A = 25°C	-65	-50	-35	Gs
	B _{HYST} , T _A = 25°C	70	100	130	Gs

10.4 ESD Ratings

Symbol	Reference	Values	Unit
V _{ESD}	Human-body model (HBM)	AEC-Q100-002	Class II Grade
	Charged-device model (CDM)	AEC-Q100-011	±1000 V

10.5 Characteristic Performance

At $V_{CC}=5V$

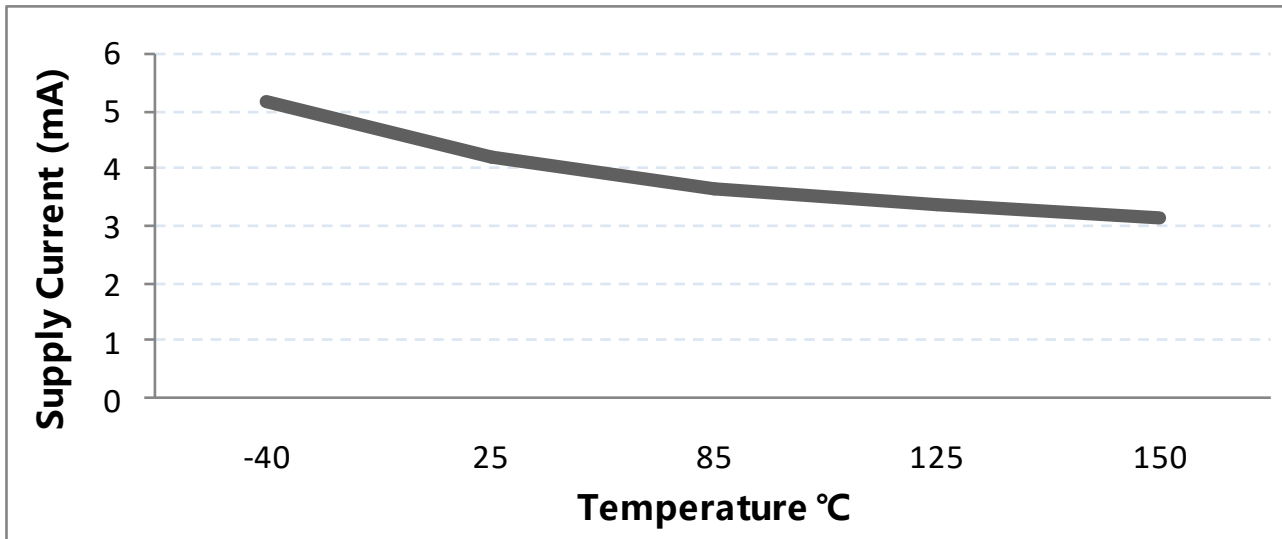

Figure.6 Supply Current vs. Temperature

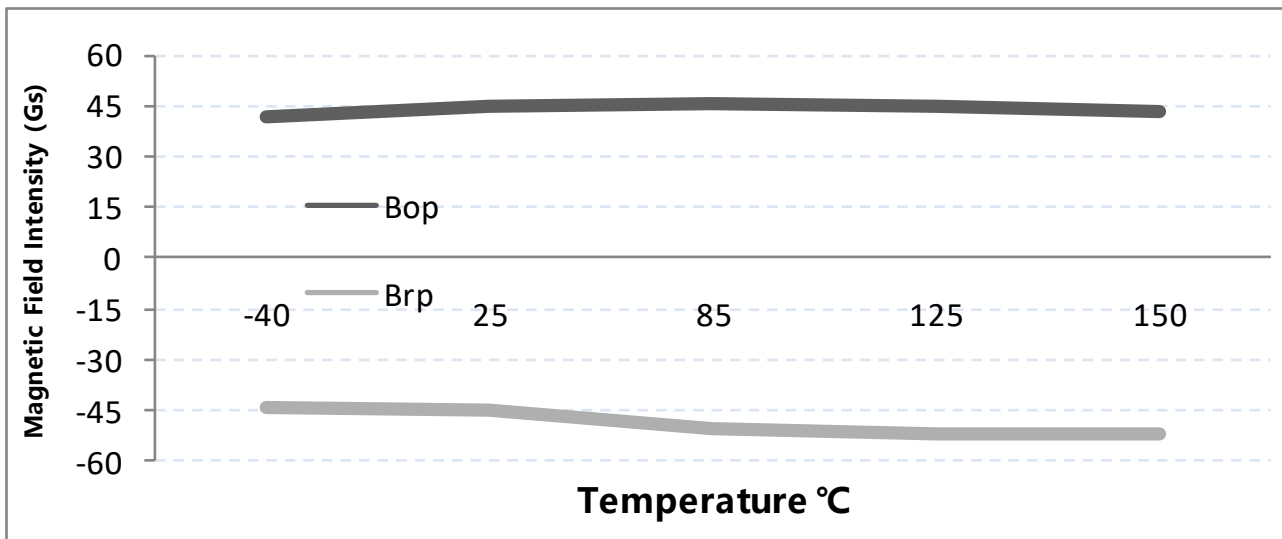

Figure.7 Magnetic Characteristics vs. Temperature (BOP & BRP)

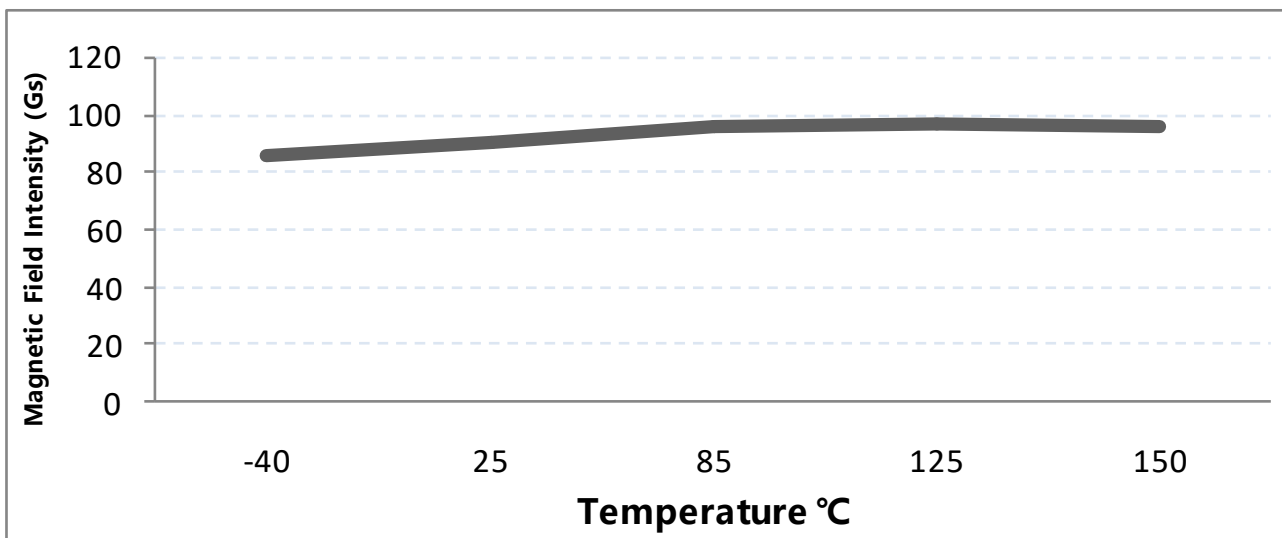

Figure.8 Magnetic Characteristics vs. Temperature (BHYST)

10.6 Typical Output Waveform

MT4401A-EN as example

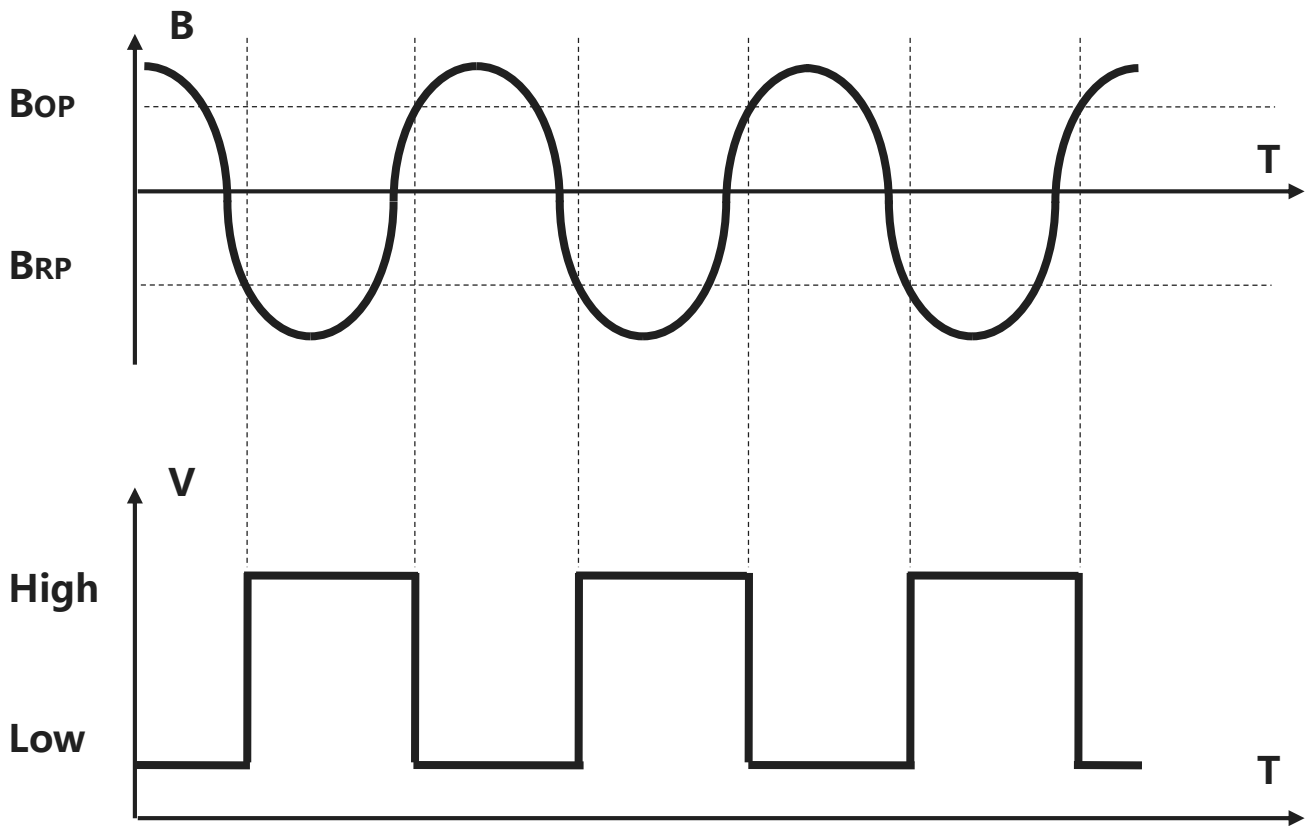

Figure.9 Digital Output vs. Magnetic Flux Density

11 Typical Application Circuit

MT4401AT-EN as example

Note: Recommended value for R_L is 1KOhms to 10KOhms

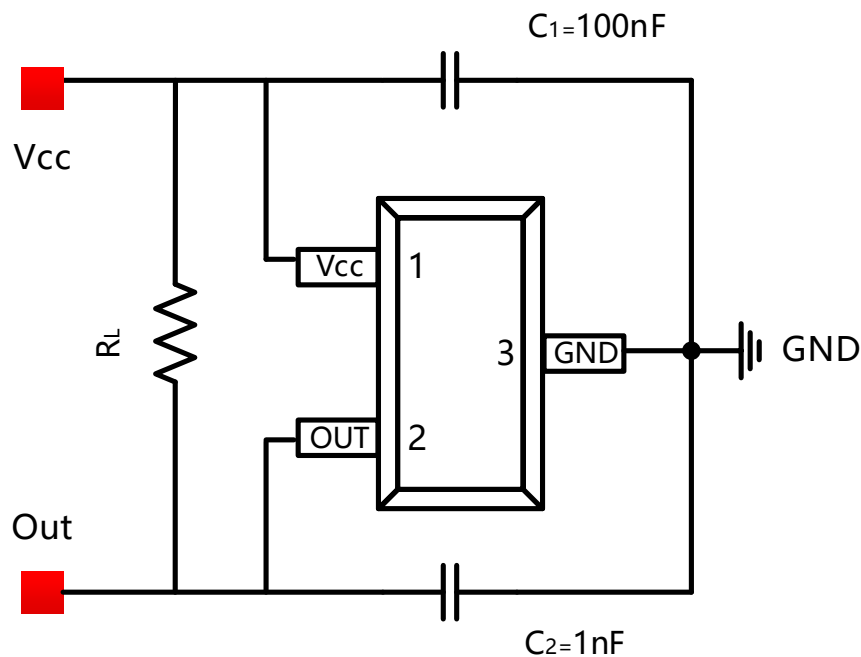

Figure.10 Typical Application Circuit

12 Package Material Information (For Reference Only – Not for Tooling Use)

12.1 SOT-23 Package Information

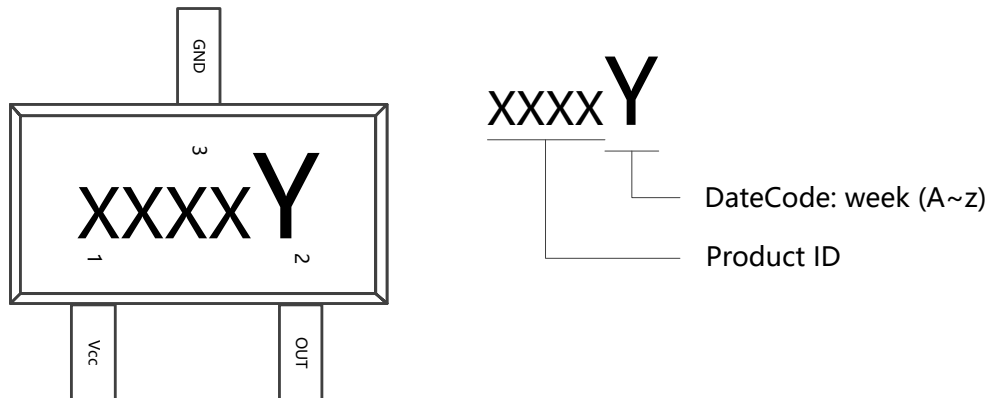

Figure.11 SOT-23 Chip Marking Spec

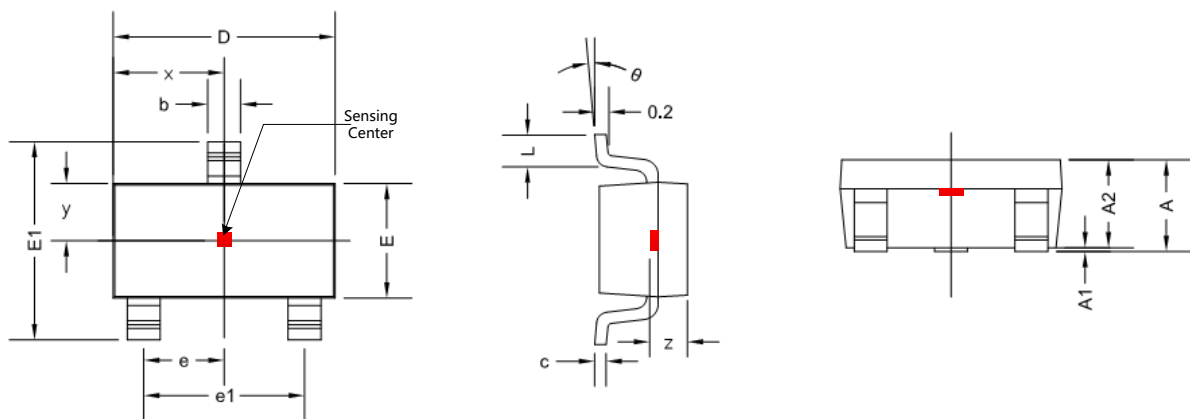

Figure.12 SOT-23 Package Drawing

Symbol	Dimensions in Millimeters		Dimensions in Inches	
	Min	Max	Min	Max
A	1.050	1.250	0.041	0.049
A1	0.000	0.100	0.000	0.004
A2	1.050	1.150	0.041	0.045
b	0.300	0.500	0.012	0.020
c	0.100	0.200	0.004	0.008
D	2.820	3.020	0.111	0.119
E	1.500	1.700	0.059	0.067
E1	2.650	2.950	0.104	0.116
e	0.950 TYP		0.037 TYP	
e1	1.800	2.000	0.071	0.079
L	0.300	0.600	0.012	0.024
θ	0 °	8 °	0 °	8 °
x	1.460 TYP		0.057 TYP	
y	0.800 TYP		0.032 TYP	
z	0.600 TYP		0.024 TYP	

12.2 SOT-89B Package Information

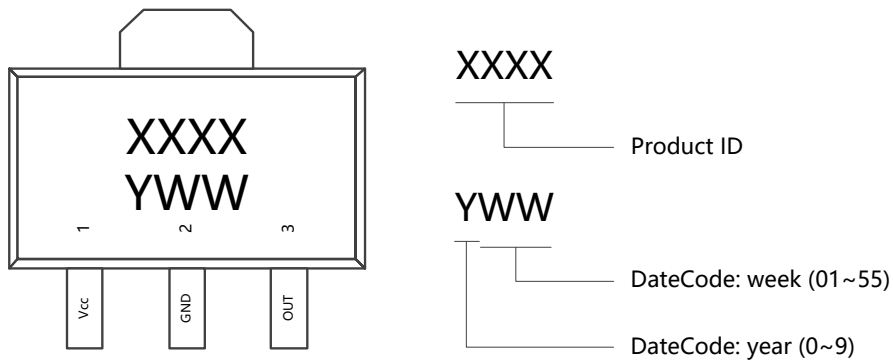

Figure.13 SOT-89B Chip Marking Spec

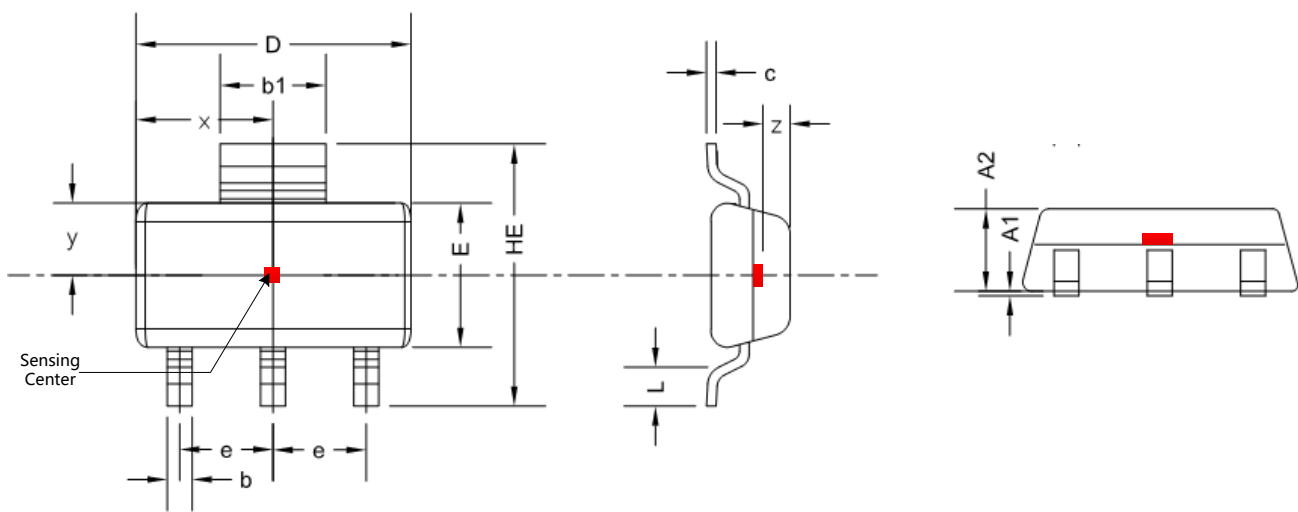

Figure.14 SOT-89B Package Drawing

Symbol	Dimensions in Millimeters		Dimensions in Inches	
	Min	Max	Min	Max
A2	1.220	1.420	0.048	0.056
A1	0.000	0.100	0.000	0.004
b	0.300	0.500	0.012	0.020
c	0.052	0.252	0.002	0.010
D	4.400	4.600	0.173	0.181
b1	1.600	1.800	0.063	0.071
E	2.400	2.600	0.094	0.102
HE	4.000	4.400	0.157	0.173
e	1.400	1.600	0.055	0.063
L	0.350	0.550	0.014	0.022
x	2.250 TYP		0.089 TYP	
y	1.250 TYP		0.049 TYP	
z	0.300 TYP		0.012 TYP	

12.3 Flat TO-92 Package Information

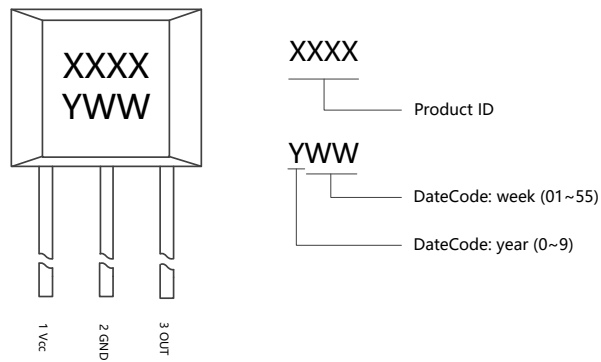

Figure.15 Flat TO-92 Chip Marking Spec

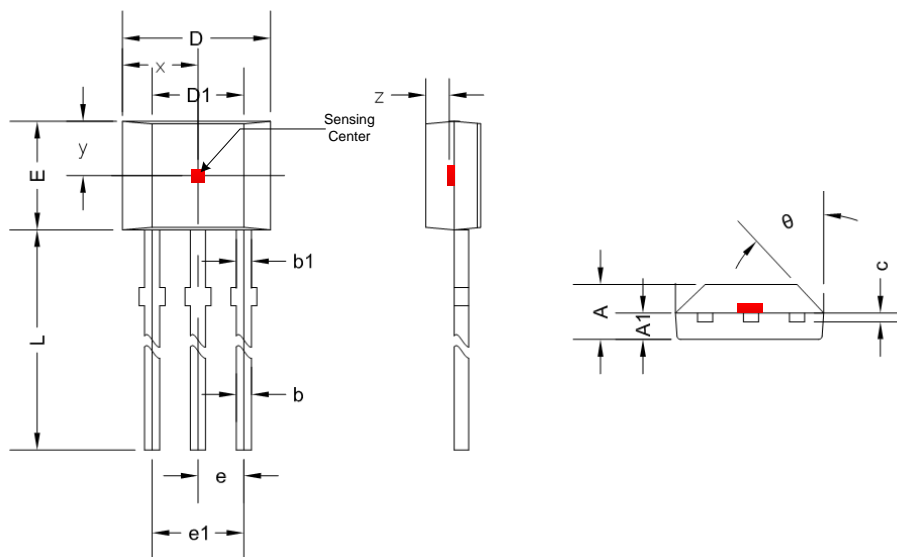

Figure.16 Flat TO-92 Package Drawing

Symbol	Dimensions in Millimeters		Dimensions in Inches	
	Min	Max	Min	Max
A	1.420	1.620	0.056	0.064
A1	0.660	0.860	0.026	0.034
b	0.350	0.480	0.013	0.019
b1	0.400	0.510	0.016	0.020
c	0.330	0.510	0.013	0.020
D	3.900	4.100	0.154	0.161
D1	2.280	2.680	0.090	0.106
E	3.050	3.250	0.120	0.128
e	1.270 TYP		0.050 TYP	
e1	2.440	2.640	0.096	0.104
L	14.350	14.750	0.565	0.581
θ	45 ° TYP		45 ° TYP	
x	2.025 TYP		0.080 TYP	
y	1.545 TYP		0.061 TYP	
z	0.500 TYP		0.020 TYP	

X-ON Electronics

Largest Supplier of Electrical and Electronic Components

Click to view similar products for [Board Mount Hall Effect/Magnetic Sensors](#) category:

Click to view products by [MagnTek](#) manufacturer:

Other Similar products are found below :

[HGPRDT005A](#) [AH277AZ4-AG1](#) [AV-10448](#) [HMC1041Z-TR](#) [SS41C](#) [TLE4917](#) [TLE4946-1L](#) [50017859-003](#) [TY-13101](#) [TLE4976L](#)
[SS85CA](#) [BU52002GUL-E2](#) [BU52003GUL-E2](#) [AH277AZ4-BG1](#) [TLE49614MXTSA1](#) [AH3376-P-B](#) [TLE4941](#) [AH211Z4-AG1](#) [AH3360-](#)
[FT4-7](#) [TLE4941-1](#) [AH374-P-A](#) [AH1913-W-7](#) [AH3373-P-B](#) [TLE9852QXXUMA1](#) [MA732GQ-Z](#) [MA330GQ-Z](#) [S-57K1NBL2A-M3T2U](#) [S-](#)
[57P1NBL9S-M3T4U](#) [S-576ZNL2B-L3T2U](#) [S-576ZNL2B-A6T8U](#) [S-57P1NBL0S-M3T4U](#) [S-57A1NSL1A-M3T2U](#) [S-57K1RBL1A-M3T2U](#)
[S-57P1NBH9S-M3T4U](#) [S-57P1NBH0S-M3T4U](#) [S-57A1NSH1A-M3T2U](#) [S-57A1NSH2A-M3T2U](#) [S-57K1NBH1A-M3T2U](#) [S-57A1NNL1A-](#)
[M3T2U](#) [S-5701BC10B-L3T2U5](#) [S-5701BC11B-L3T2U5](#) [S-57GNNL3S-A6T8U](#) [S-57TZ1L1S-A6T8U](#) [S-57GSNL3S-A6T8U](#) [S-](#)
[5716ANDH0-I4T1U](#) [S-57GSNL5S-L3T2U](#) [S-57GDNL3S-L3T2U](#) [S-57GNNL3S-L3T2U](#) [S-57RBNL8S-L3T2U](#) [S-57RBNL9S-A6T8U](#)