



**SAMXON BRAND ALUMINUM ELECTROLYTIC CAPACITORS**

**PRODUCT SPECIFICATION**

**規格書**

<b>CUSTOMER :</b> (客戶) :	<b>DATE :</b> (日期) : 2017-10-27
-----------------------------	------------------------------------

CATEGORY (品名)	: ALUMINUM ELECTROLYTIC CAPACITORS
DESCRIPTION (型号)	: KM 63V2200 $\mu$ F( $\phi$ 18x35)
VERSION (版本)	: 01
Customer P/N	:
SUPPLIER	:

<b>SUPPLIER</b>	
<b>PREPARED</b> (拟定)	<b>CHECKED</b> (审核)
李婷	刘渭清

<b>CUSTOMER</b>	
<b>APPROVAL</b> (批准)	<b>SIGNATURE</b> (签名)

<b>MAN YUE ELECTRONICS COMPANY LIMITED</b>	<i>ELECTROLYTIC CAPACITOR SPECIFICATION KM SERIES</i>	<b>SAMXON</b>

SPECIFICATION					ALTERNATION HISTORY RECORDS		
KM SERIES							
Rev.	Date	Mark	Page	Contents	Purpose	Drafter	Approver

MAN YUE ELECTRONICS  
COMPANY LIMITED

ELECTROLYTIC  
CAPACITOR  
SPECIFICATION  
KM SERIES

**Table 1 Product Dimensions and Characteristics**

Safety vent for  $\geq \Phi 6.3$

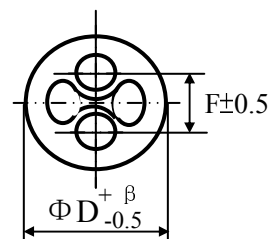
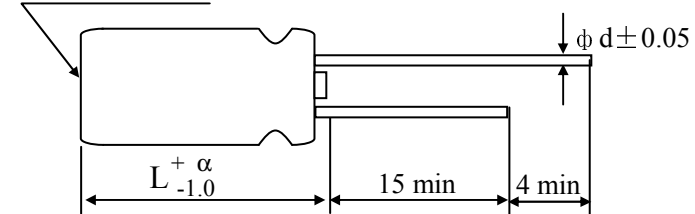

Unit: mm

$\alpha$	$L < 20 : \alpha$
$\beta$	$\Phi D < 20$

\* If it is flat rubber, there is

No.	SAMXON Part No.	WV (Vdc)	Cap. ( $\mu$ F)	Cap. tolerance	Temp. range( $^{\circ}$ C)	$\tan \delta$ (120Hz, 20 $^{\circ}$ C)	Leakage Current ( $\mu$ A,2min)	Max Ripple Current at 105 $^{\circ}$ C 120Hz (mA rms)	Load lifetime (Hrs)
1	EKM228M1JL35RR**P	63	2200	-20%~+20%	-40~105	0.10	1386	1781	2000

**C O N T E N T S**

	<b>Sheet</b>
1. Application	4
2. Part Number System	4
3. Construction	5
4. Characteristics	5~10
4.1 Rated voltage & Surge voltage	
4.2 Capacitance (Tolerance)	
4.3 Leakage current	
4.4 $\tan \delta$	
4.5 Terminal strength	
4.6 Temperature characteristic	
4.7 Load life test	
4.8 Shelf life test	
4.9 Surge test	
4.10 Vibration	
4.11 Solderability test	
4.12 Resistance to solder heat	
4.13 Change of temperature	
4.14 Damp heat test	
4.15 Vent test	
4.16 Maximum permissible (ripple current)	
5. List of “Environment-related Substances to be Controlled (‘Controlled Substances’)”	11
Attachment: Application Guidelines	12~15

**1. Application**

This specification applies to polar Aluminum electrolytic capacitor (foil type) used in electronic equipment. Designed capacitor's quality meets IEC60384.

**2. Part Number System**



Series	Cap(MFD)	Code	Tolerance (%)	Code	Voltage (W.V.)	Code	Case Size	Code	Feature	Code	SAMXON Product Line
ESM	0.1	104	± 5	J	2	0D	3	B	Radial bulk	RR	For internal use only (The product lines we have H,A,B,C,D, E,M or 0,1,2,3,4,5,9).
EKF					2.5	0E	3.5	1	Ammo Taping	C	
ESS					4	0G	4	2			
EKS	0.22	224	± 10	K	6.3	0J	5	D	2.0mm Pitch	TT	
EGS					8	0K	6.3	E			
EKM					10	1A	8	F			
EKG	0.33	334	± 15	L	12.5	1B	10	G	2.5mm Pitch	TU	
EOM					16	1C	12.5	I			
EZM					20	1D	13	J			
EZS	0.47	474	± 20	M	25	1E	13.5	V	3.5mm Pitch	TV	
EGF					30	1I	14	4			
ESF					32	13	14.5	A			
EGT	1	105	± 30	N	40	1G	16	K	5.0mm Pitch	TC	
EGK					42	1M	16.5	7			
EKE					50	1H	18	L			
EGE	2.2	225	-40	W	57	1L	18.5	8	Lead Cut & Form		
EGD					75	1T	20	M			
EGC					80	1K	22	N			
ERS	3.3	335	-20	A	85	1R	25	O	CB-Type	CB	
ERF					90	19	30	P			
ERL					100	2A	34	W			
ERR	4.7	475	-20	C	120	2O	35	Q	CE-Type	CE	
ERT					125	2B	40	R			
ERE					150	2Z	42	4			
ERD	10	106	+10		175	2T	45	6	HE-Type	HE	
ERH					200	2D	45	6			
ERB					215	22	51	S			
ERK	22	226	-20	X	275	2T	63.5	T	KD-Type	KD	
ERC					300	2I	76	U			
ERB					310	2R	80	8			
ERB	33	336	+40	X	315	2F	90	X	FD-Type	FD	
ERC					350	2V	90	X			
ERB					375	2Q	100	Z			
EFA	47	476	-20	S	385	2Y	105	1K	EH-Type	EH	
ENP					400	2G	110	1M			
ENH					420	2M	115	1A			
ERW	100	107	-10	B	450	2G	12	12	Snap-in	SX	
ERY					475	22	12.5	1B			
ELP					220	2N	13	13			
EAP	220	227	-10	V	220	2N	13.5	1C	Lug	SG	
EQP					230	23	20	20			
EDP					250	2E	25	25			
ETP	330	337	-10	Q	275	2T	29.5	2J	Screw	O5	
EHP					300	2I	30	30			
EUP					310	2R	31.5	3A			
EKP	470	477	+30		315	2F	35	35	O6	T5	
EKP					330	2U	35.5	3E			
EKP					350	2V	50	50			
EFP	2200	228	-5	E	350	2V	80	80	D5	D6	
ESP					330	2U	100	1L			
EVP					350	2V	105	1K			
EGP	22000	229	+5	F	110	1M	110	1M	D5	D6	
EWR					120	1N	120	1N			
EWU					130	1P	130	1P			
EWT	33000	339	+20	G	140	1Q	140	1Q	D5	D6	
EWX					150	1R	150	1R			
EWX					155	1E	155	1E			
EWX	47000	479	0	R	160	1S	160	1S	D5	D6	
EWX					165	1F	165	1F			
EWX					170	1T	170	1T			
EWL	100000	10T	+20		180	1U	180	1U	D5	D6	
EWL					190	1V	190	1V			
EWL					200	2L	200	2L			
EWB	150000	15T	0	O	215	2A	215	2A	D5	D6	
VSS					220	2M	220	2M			
VNS					220	2M	220	2M			
VKS	220000	22T	+5	Z	240	2Q	240	2Q	D5	D6	
VKM					250	2R	250	2R			
VRL					260	2S	260	2S			
VNH	330000	33T	+15		270	2T	270	2T	D5	D6	
VZS					270	2T	270	2T			
VRF					270	2T	270	2T			
	1000000	10M	+10		550	25	190	1V			
	1500000	15M	+50	Y	600	26	200	2L			
	2200000	22M	+10	H	630	2J	215	2A			
	3300000	33M	+30				220	2N			
							240	2Q			
							250	2R			
							260	2S			
							270	2T			

### 3. Construction

Single ended type to be produced to fix the terminals to anode and cathode foil, and wind together with paper, and then wound element to be impregnated with electrolyte will be enclosed in an aluminum case. Finally sealed up tightly with end seal rubber, then finished by putting on the vinyl sleeve.

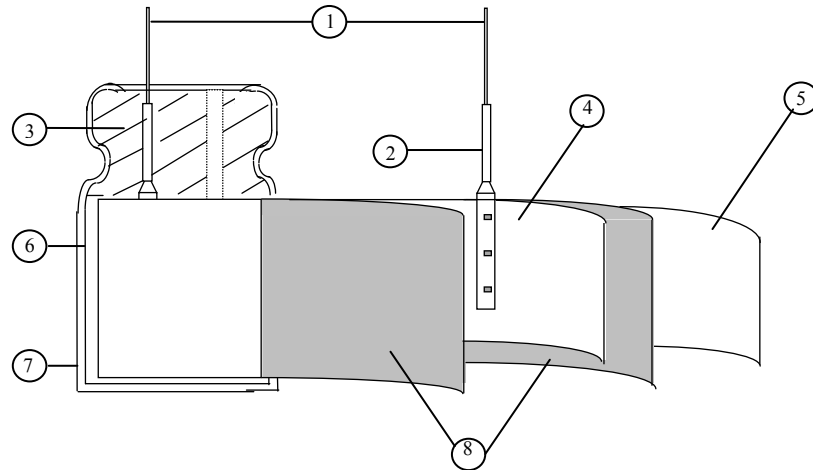

	<b>Component</b>	<b>Material</b>
1	Lead line	Tinned CP wire (Pb Free)
2	Terminal	Aluminum wire
3	Sealing Material	Rubber
4	Al-Foil (+)	Formed aluminum foil
5	Al-Foil (-)	Etched aluminum foil or formed aluminum foil
6	Case	Aluminum case
7	Sleeve	PET
8	Separator	Electrolyte paper

### 4. Characteristics

#### Standard atmospheric conditions

Unless otherwise specified, the standard range of atmospheric conditions for making measurements and tests are as follows:

Ambient temperature	: 15°C to 35°C
Relative humidity	: 45% to 85%
Air Pressure	: 86kPa to 106kPa

If there is any doubt about the results, measurement shall be made within the following conditions:

Ambient temperature	: 20°C ± 2°C
Relative humidity	: 60% to 70%
Air Pressure	: 86kPa to 106kPa

#### Operating temperature range

The ambient temperature range at which the capacitor can be operated continuously at rated voltage  
See table 1 temperature range.

As to the detailed information, please refer to table 2.

MAN YUE ELECTRONICS COMPANY LIMITED	ELECTROLYTIC CAPACITOR SPECIFICATION KM SERIES	SAMXON

Table 2

ITEM		PERFORMANCE																	
4.1	Rated voltage (WV)	WV (V.DC)	6.3	10	16	25	35	50	63	100									
		SV (V.DC)	8	13	20	32	44	63	79	125									
	Surge voltage (SV)	WV (V.DC)	160	200	220	250	350	400	420	450									
		SV (V.DC)	200	250	270	300	400	450	470	500									
4.2	Nominal capacitance (Tolerance)	<p><b>&lt;Condition&gt;</b>            Measuring Frequency : 120Hz ± 12Hz            Measuring Voltage : Not more than 0.5Vrms            Measuring Temperature : 20 ± 2°C</p> <p><b>&lt;Criteria&gt;</b>            Shall be within the specified capacitance tolerance.</p>																	
4.3	Leakage current	<p><b>&lt;Condition&gt;</b>            Connecting the capacitor with a protective resistor (1kΩ ± 10Ω) in series for 2 minutes, and then, measure Leakage Current.</p> <p><b>&lt;Criteria&gt;</b>            Refer to Table 1</p>																	
4.4	tan δ	<p><b>&lt;Condition&gt;</b>            See 4.2, Norm Capacitance, for measuring frequency, voltage and temperature.</p> <p><b>&lt;Criteria&gt;</b>            Refer to Table 1</p>																	
4.5	Terminal strength	<p><b>&lt;Condition&gt;</b>            Tensile Strength of Terminals            Fixed the capacitor, applied force to the terminal in lead out direction for 10 ± 1 seconds.            Bending Strength of Terminals.            Fixed the capacitor, applied force to bent the terminal (1~4 mm from the rubber) for 90° within 2~3 seconds, and then bent it for 90° to its original position within 2~3 seconds.</p> <table border="1"> <thead> <tr> <th>Diameter of lead wire</th> <th>Tensile force N (kgf)</th> <th>Bending force N (kgf)</th> </tr> </thead> <tbody> <tr> <td>0.5mm and less</td> <td>5 (0.51)</td> <td>2.5 (0.25)</td> </tr> <tr> <td>Over 0.5mm to 0.8mm</td> <td>10 (1.0)</td> <td>5 (0.51)</td> </tr> </tbody> </table> <p><b>&lt;Criteria&gt;</b>            No noticeable changes shall be found, no breakage or looseness at the terminal.</p>									Diameter of lead wire	Tensile force N (kgf)	Bending force N (kgf)	0.5mm and less	5 (0.51)	2.5 (0.25)	Over 0.5mm to 0.8mm	10 (1.0)	5 (0.51)
		Diameter of lead wire	Tensile force N (kgf)	Bending force N (kgf)															
		0.5mm and less	5 (0.51)	2.5 (0.25)															
		Over 0.5mm to 0.8mm	10 (1.0)	5 (0.51)															

4.6 Temperature characteristics

**<Condition>**

STEP	Testing Temperature(°C)	Time
1	20±2	Time to reach thermal equilibrium
2	-40(-25) ±3	Time to reach thermal equilibrium
3	20±2	Time to reach thermal equilibrium
4	105±2	Time to reach thermal equilibrium
5	20±2	Time to reach thermal equilibrium

**<Criteria>**

- a.  $\tan \delta$  shall be within the limit of Item 4.4The leakage current measured shall not more than 8 times of its specified value.
- b. In step 5,  $\tan \delta$  shall be within the limit of Item 4.4The leakage current shall not more than the specified value.
- c. At -40°C (-25°C), impedance (z) ratio shall not exceed the value of the following table.

Working Voltage (V)	6.3	10	16	25	35	50	63
Z-25°C/Z+20°C	5	4	3	2	2	2	2
Z-40°C/Z+20°C	10	8	6	4	3	3	3

Working Voltage (V)	100	160~220	250~350	400~420	450
Z-25°C/Z+20°C	2	3	4	6	15
Z-40°C/Z+20°C	3	---	---	---	---

For capacitance value > 1000 μ F, Add 0.5 per another 1000 μ F for Z-25/Z+20°C,  
Add 1.0 per another 1000 μ F for Z-40°C/Z+20°C.

Capacitance,  $\tan \delta$ , and impedance shall be measured at 120Hz.

4.7

Load life test

**<Condition>**

According to IEC60384-4No.4.13 methods, The capacitor is stored at a temperature of 105°C ±2 with DC bias voltage plus the rated ripple current for Table 1. (The sum of DC and ripple peak voltage shall not exceed the rated working voltage) Then the product should be tested after 16 hours recovering time at atmospheric conditions. The result should meet the following table:

**<Criteria>**

The characteristic shall meet the following requirements.

Leakage current	Value in 4.3 shall be satisfied
Capacitance Change	Within ±20% of initial value.
$\tan \delta$	Not more than 200% of the specified value.
Appearance	There shall be no leakage of electrolyte.

4.8

Shelf life test

**<Condition>**

The capacitors are then stored with no voltage applied at a temperature of 105±2°C for 1000+48/0 hours. Following this period the capacitors shall be removed from the test chamber and be allowed to stabilized at room temperature for 4~8 hours. Next they shall be connected to a series limiting resistor(1k±100Ω) with D.C. rated voltage applied for 30min. After which the capacitors shall be discharged, and then, tested the characteristics.



4.8 Shelf life test

**<Criteria>**

The characteristic shall meet the following requirements.

Leakage current	Value in 4.3 shall be satisfied
Capacitance Change	Within $\pm 20\%$ of initial value.
$\tan \delta$	Not more than 200% of the specified value.
Appearance	There shall be no leakage of electrolyte.

Remark: If the capacitors are stored more than 1 year, the leakage current may increase. Please apply voltage through about 1 k $\Omega$  resistor, if necessary.

4.9 Surge test

**<Condition>**

Applied a surge voltage to the capacitor connected with a  $(100 \pm 50)/C_R$  (k $\Omega$ ) resistor. The capacitor shall be submitted to 1000 cycles, each consisting of charge of  $30 \pm 5s$ , followed discharge of 5 min 30s.

The test temperature shall be 15~35 $^{\circ}C$ .

$C_R$ : Nominal Capacitance ( $\mu F$ )

**<Criteria>**

Leakage current	Not more than the specified value.
Capacitance Change	Within $\pm 15\%$ of initial value.
$\tan \delta$	Not more than the specified value.
Appearance	There shall be no leakage of electrolyte.

Attention:

This test simulates over voltage at abnormal situation only. It is not applicable to such over voltage as often applied.

4.10 Vibration test

**<Condition>**

The following conditions shall be applied for 2 hours in each 3 mutually perpendicular directions.

Vibration frequency range : 10Hz ~ 55Hz

Peak to peak amplitude : 1.5mm

Sweep rate : 10Hz ~ 55Hz ~ 10Hz in about 1 minute

Mounting method:

The capacitor with diameter greater than 12.5mm or longer than 25mm must be fixed in place with a bracket.

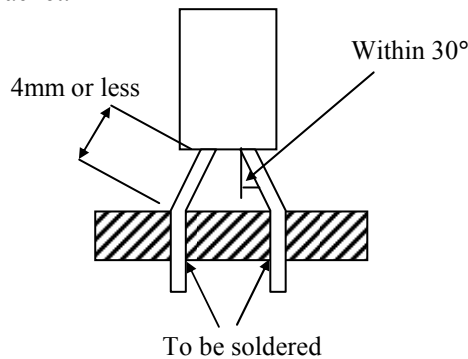

**<Criteria>**

After the test, the following items shall be tested:

Inner construction	No intermittent contacts, open or short circuiting. No damage of tab terminals or electrodes.
Appearance	No mechanical damage in terminal. No leakage of electrolyte or swelling of the case. The markings shall be legible.

4.11	Solderability test	<p><b>&lt;Condition&gt;</b> The capacitor shall be tested under the following conditions: Soldering temperature : 245±3°C Dipping depth : 2mm Dipping speed : 25±2.5mm/s Dipping time : 3±0.5s</p> <p><b>&lt;Criteria&gt;</b></p> <table border="1" style="width: 100%; border-collapse: collapse;"> <tr> <td style="width: 50%;">Coating quality</td> <td>A minimum of 95% of the surface being immersed</td> </tr> </table>	Coating quality	A minimum of 95% of the surface being immersed														
Coating quality	A minimum of 95% of the surface being immersed																	
4.12	Resistance to solder heat test	<p><b>&lt;Condition&gt;</b> Terminals of the capacitor shall be immersed into solder bath at 260±5°C for 10±1 seconds or 400±10°C for 3<sup>+1</sup><sub>-0</sub> seconds to 1.5~2.0mm from the body of capacitor . Then the capacitor shall be left under the normal temperature and normal humidity for 1~2 hours before measurement.</p> <p><b>&lt;Criteria&gt;</b></p> <table border="1" style="width: 100%; border-collapse: collapse;"> <tr> <td style="width: 50%;">Leakage current</td> <td>Not more than the specified value.</td> </tr> <tr> <td>Capacitance Change</td> <td>Within ± 10% of initial value.</td> </tr> <tr> <td>tan δ</td> <td>Not more than the specified value.</td> </tr> <tr> <td>Appearance</td> <td>There shall be no leakage of electrolyte.</td> </tr> </table>	Leakage current	Not more than the specified value.	Capacitance Change	Within ± 10% of initial value.	tan δ	Not more than the specified value.	Appearance	There shall be no leakage of electrolyte.								
Leakage current	Not more than the specified value.																	
Capacitance Change	Within ± 10% of initial value.																	
tan δ	Not more than the specified value.																	
Appearance	There shall be no leakage of electrolyte.																	
4.13	Change of temperature test	<p><b>&lt;Condition&gt;</b> Temperature Cycle: According to IEC60384-4 No.4.7 methods, capacitor shall be placed in an oven, the condition according as below:</p> <table border="1" style="width: 100%; border-collapse: collapse;"> <thead> <tr> <th style="width: 60%;">Temperature</th> <th>Time</th> </tr> </thead> <tbody> <tr> <td>(1)+20°C</td> <td>≤3 Minutes</td> </tr> <tr> <td>(2)Rated low temperature (-40°C) (-25°C)</td> <td>30±2 Minutes</td> </tr> <tr> <td>(3)Rated high temperature (+105°C)</td> <td>30±2 Minutes</td> </tr> <tr> <td colspan="2">(1) to (3)=1 cycle, total 5 cycle</td> </tr> </tbody> </table> <p><b>&lt;Criteria&gt;</b> The characteristic shall meet the following requirement</p> <table border="1" style="width: 100%; border-collapse: collapse;"> <tr> <td style="width: 50%;">Leakage current</td> <td>Not more than the specified value.</td> </tr> <tr> <td>tan δ</td> <td>Not more than the specified value.</td> </tr> <tr> <td>Appearance</td> <td>There shall be no leakage of electrolyte.</td> </tr> </table>	Temperature	Time	(1)+20°C	≤3 Minutes	(2)Rated low temperature (-40°C) (-25°C)	30±2 Minutes	(3)Rated high temperature (+105°C)	30±2 Minutes	(1) to (3)=1 cycle, total 5 cycle		Leakage current	Not more than the specified value.	tan δ	Not more than the specified value.	Appearance	There shall be no leakage of electrolyte.
Temperature	Time																	
(1)+20°C	≤3 Minutes																	
(2)Rated low temperature (-40°C) (-25°C)	30±2 Minutes																	
(3)Rated high temperature (+105°C)	30±2 Minutes																	
(1) to (3)=1 cycle, total 5 cycle																		
Leakage current	Not more than the specified value.																	
tan δ	Not more than the specified value.																	
Appearance	There shall be no leakage of electrolyte.																	
4.14	Damp heat test	<p><b>&lt;Condition&gt;</b> Humidity Test: According to IEC60384-4 No.4.12 methods, capacitor shall be exposed for 500±8 hours in an atmosphere of 90~95%RH .at 40±2°C, the characteristic change shall meet the following requirement.</p> <p><b>&lt;Criteria&gt;</b></p> <table border="1" style="width: 100%; border-collapse: collapse;"> <tr> <td style="width: 50%;">Leakage current</td> <td>Not more than the specified value.</td> </tr> <tr> <td>Capacitance Change</td> <td>Within ± 20% of initial value.</td> </tr> <tr> <td>tan δ</td> <td>Not more than 120% of the specified value.</td> </tr> <tr> <td>Appearance</td> <td>There shall be no leakage of electrolyte.</td> </tr> </table>	Leakage current	Not more than the specified value.	Capacitance Change	Within ± 20% of initial value.	tan δ	Not more than 120% of the specified value.	Appearance	There shall be no leakage of electrolyte.								
Leakage current	Not more than the specified value.																	
Capacitance Change	Within ± 20% of initial value.																	
tan δ	Not more than 120% of the specified value.																	
Appearance	There shall be no leakage of electrolyte.																	

4.15

Vent  
test

**<Condition>**

The following test only apply to those products with vent products at diameter  $\geq \varnothing 6.3$  with vent.

D.C. test

The capacitor is connected with its polarity reversed to a DC power source. Then a current selected from below table is applied.

<Table 3>

Diameter (mm)	DC Current (A)
22.4 or less	1
Over 22.4	10

**<Criteria>**

The vent shall operate with no dangerous conditions such as flames or dispersion of pieces of the capacitor and/or case.

4.16

Maximum  
permissible  
(ripple  
current)

**<Condition>**

The maximum permissible ripple current is the maximum A.C current at 120Hz and can be applied at maximum operating temperature

Table-1

The combined value of D.C voltage and the peak A.C voltage shall not exceed the rated voltage and shall not reverse voltage.

Frequency Multipliers:

Rated Voltage (V)	Coefficient Cap.( $\mu$ F)	Freq. (Hz)				
		50	120	300	1k	10k~
6.3~100	~47	0.75	1.00	1.35	1.57	2.00
	68~470	0.80	1.00	1.23	1.34	1.50
	$\geq 560$	0.85	1.00	1.10	1.13	1.15
160~450	0.47~220	0.80	1.00	1.25	1.40	1.60
	$\geq 270$	0.90	1.00	1.10	1.13	1.15

5. It refers to the latest document of “Environment-related Substances standard”(WI-HSPM-QA-072).

Substances	
Heavy metals	Cadmium and cadmium compounds
	Lead and lead compounds
	Mercury and mercury compounds
	Hexavalent chromium compounds
Chloinated organic compounds	Polychlorinated biphenyls (PCB)
	Polychlorinated naphthalenes (PCN)
	Polychlorinated terphenyls (PCT)
	Short-chain chlorinated paraffins(SCCP)
	Other chlorinated organic compounds
Brominated organic compounds	Polybrominated biphenyls (PBB)
	Polybrominated diphenylethers(PBDE) (including decabromodiphenyl ether[DecaBDE])
	Other brominated organic compounds
Tributyltin compounds(TBT)	
Triphenyltin compounds(TPT)	
Asbestos	
Specific azo compounds	
Formaldehyde	
Beryllium oxide	
Beryllium copper	
Specific phthalates (DEHP,DBP,BBP,DINP,DIDP,DNOP,DNHP)	
Hydrofluorocarbon (HFC), Perfluorocarbon (PFC)	
Perfluorooctane sulfonates (PFOS)	
Specific Benzotriazole	

<b>MAN YUE ELECTRONICS COMPANY LIMITED</b>	<i>ELECTROLYTIC CAPACITOR SPECIFICATION KM SERIES</i>	<b>SAMXON</b>

**Attachment: Application Guidelines**

**1.Circuit Design**

**1.1 Operating Temperature and Frequency**

Electrolytic capacitor electrical parameters are normally specified at 20°C temperature and 120Hz frequency. These parameters vary with changes in temperature and frequency. Circuit designers should take these changes into consideration.

- (1) Effects of operating temperature on electrical parameters
  - a) At higher temperatures, leakage current and capacitance increase while equivalent series resistance (ESR) decreases.
  - b) At lower temperatures, leakage current and capacitance decrease while equivalent series resistance (ESR) increases.
- (2) Effects of frequency on electrical parameters
  - a) At higher frequencies capacitance and impedance decrease while  $\tan\delta$  increases.
  - b) At lower frequencies, ripple current generated heat will rise due to an increase in equivalent series resistance (ESR).

**1.2 Operating Temperature and Life Expectancy**

See the file: Life calculation of aluminum electrolytic capacitor

**1.3 Common Application Conditions to Avoid**

The following misapplication load conditions will cause rapid deterioration to capacitor electrical parameters. In addition, rapid heating and gas generation within the capacitor can occur causing the pressure relief vent to operate and resultant leakage of electrolyte. Under Leaking electrolyte is combustible and electrically conductive.

- (1) Reverse Voltage  
DC capacitors have polarity. Verify correct polarity before insertion. For circuits with changing or uncertain polarity, use DC bipolar capacitors. DC bipolar capacitors are not suitable for use in AC circuits.
- (2) Charge / Discharge Applications  
Standard capacitors are not suitable for use in repeating charge / discharge applications. For charge / discharge applications consult us and advise actual conditions.
- (3) Over voltage  
Do not apply voltages exceeding the maximum specified rated voltage. Voltages up to the surge voltage rating are acceptable for short periods of time. Ensure that the sum of the DC voltage and the superimposed AC ripple voltage does not exceed the rated voltage.
- (4) Ripple Current  
Do not apply ripple currents exceeding the maximum specified value. For high ripple current applications, use a capacitor designed for high ripple currents or contact us with your requirements. Ensure that allowable ripple currents superimposed on low DC bias voltages do not cause reverse voltage conditions.

**1.4 Using Two or More Capacitors in Series or Parallel**

- (1) Capacitors Connected in Parallel  
The circuit resistance can closely approximate the series resistance of the capacitor causing an imbalance of ripple current loads within the capacitors. Careful design of wiring methods can minimize the possibility of excessive ripple currents applied to a capacitor.
- (2) Capacitors Connected in Series  
Normal DC leakage current differences among capacitors can cause voltage imbalances. The use of voltage divider shunt resistors with consideration to leakage current can prevent capacitor voltage imbalances.

**1.5 Capacitor Mounting Considerations**

- (1) Double Sided Circuit Boards  
Avoid wiring pattern runs, which pass between the mounted capacitor and the circuit board.  
When dipping into a solder bath, excess solder may collect under the capacitor by capillary action and short circuit the anode and cathode terminals.
- (2) Circuit Board Hole Positioning  
The vinyl sleeve of the capacitor can be damaged if solder passes through a lead hole for subsequently processed parts. Special care when locating hole positions in proximity to capacitors is recommended.
- (3) Circuit Board Hole Spacing  
The circuit board holes spacing should match the capacitor lead wire spacing within the specified tolerances. Incorrect spacing can cause excessive lead wire stress during the insertion process. This may result in premature capacitor failure due to short or open circuit, increased leakage current, or electrolyte leakage.
- (4) Clearance for Case Mounted Pressure Relief vents  
Capacitors with case mounted pressure relief vents require sufficient clearance to allow for proper vent operation. The minimum clearances are dependent on capacitor diameters as proper vent operation. The minimum clearances are dependent on capacitor diameters as follows.  
 $\phi 6.3\sim\phi 16\text{mm}$ :2mm minimum,  $\phi 18\sim\phi 35\text{mm}$ :3mm minimum,  $\phi 40\text{mm}$  or greater:5mm minimum.
- (5) Clearance for Seal Mounted Pressure Relief Vents  
A hole in the circuit board directly under the seal vent location is required to allow proper release of pressure.

Version	01	Page	12
---------	----	------	----

<b>MAN YUE ELECTRONICS COMPANY LIMITED</b>	<i>ELECTROLYTIC CAPACITOR SPECIFICATION KM SERIES</i>	<b>SAMXON</b>

(6) Wiring Near the Pressure Relief Vent

Avoid locating high voltage or high current wiring or circuit board paths above the pressure relief vent. Flammable, high temperature gas exceeding 100°C may be released which could dissolve the wire insulation and ignite.

(7) Circuit Board patterns Under the Capacitor

Avoid circuit board runs under the capacitor as electrolyte leakage could cause an electrical short.

(8) Screw Terminal Capacitor Mounting

Do not orient the capacitor with the screw terminal side of the capacitor facing downwards.

Tighten the terminal and mounting bracket screws within the torque range specified in the specification.

1.6 Electrical Isolation of the Capacitor

Completely isolate the capacitor as follows.

- (1) Between the cathode and the case (except for axially leaded B types) and between the anode terminal and other circuit paths
- (2) Between the extra mounting terminals (on T types) and the anode terminal, cathode terminal, and other circuit paths.

1.7 The Product endurance should take the sample as the standard.

1.8 If conduct the load or shelf life test, must be collect date code within 6 months products of sampling.

1.9 Capacitor Sleeve

The vinyl sleeve or laminate coating is intended for marking and identification purposes and is not meant to electrically insulate the capacitor.

The sleeve may split or crack if immersed into solvents such as toluene or xylene, and then exposed to high temperatures.

**CAUTION!**

Always consider safety when designing equipment and circuits. Plan for worst case failure modes such as short circuits and open circuits which could occur during use.

- (1) Provide protection circuits and protection devices to allow safe failure modes.
- (2) Design redundant or secondary circuits where possible to assure continued operation in case of main circuit failure.

**2.Capacitor Handling Techniques**

2.1 Considerations Before Using

- (1) Capacitors have a finite life. Do not reuse or recycle capacitors from used equipment.
- (2) Transient recovery voltage may be generated in the capacitor due to dielectric absorption. If required, this voltage can be discharged with a resistor with a value of about 1kΩ.
- (3) Capacitors stored for long periods of time may exhibit an increase in leakage current. This can be corrected by gradually applying rated voltage in series with a resistor of approximately 1kΩ.
- (4) If capacitors are dropped, they can be damaged mechanically or electrically. Avoid using dropped capacitors.
- (5) Dented or crushed capacitors should not be used. The seal integrity can be compromised and loss of electrolyte / shortened life can result.

2.2 Capacitor Insertion

- (1) Verify the correct capacitance and rated voltage of the capacitor.
- (2) Verify the correct polarity of the capacitor before inserting.
- (3) Verify the correct hole spacing before insertion (land pattern size on chip type) to avoid stress on the terminals.
- (4) Ensure that the auto insertion equipment lead clinching operation does not stress the capacitor leads where they enter the seal of the capacitor.

For chip type capacitors, excessive mounting pressure can cause high leakage current, short circuit, or disconnection.

2.3 Manual Soldering

- (1) Observe temperature and time soldering specifications or do not exceed temperatures of 400 °C for 3 seconds or less.
- (2) If lead wires must be formed to meet terminal board hole spacing, avoid stress on the lead wire where it enters the capacitor seal.
- (3) If a soldered capacitor must be removed and reinserted, avoid excessive stress to the capacitor leads.
- (4) Avoid touching the tip of the soldering iron to the capacitor, to prevent melting of the vinyl sleeve.

2.4 Flow Soldering

- (1) Do not immerse the capacitor body into the solder bath as excessive internal pressure could result.
- (2) Observe proper soldering conditions (temperature, time, etc.) Do not exceed the specified limits.
- (3) Do not allow other parts or components to touch the capacitor during soldering.

2.5 Other Soldering Considerations

Rapid temperature rises during the preheat operation and resin bonding operation can cause cracking of the capacitor vinyl sleeve. For heat curing, do not exceed 150°C for a maximum time of 2 minutes.

Version	01	Page	13
---------	----	------	----

<b>MAN YUE ELECTRONICS COMPANY LIMITED</b>	<i>ELECTROLYTIC CAPACITOR SPECIFICATION KM SERIES</i>	<b>SAMXON</b>

**2.6 Capacitor Handling after Solder**

- (1). Avoid movement of the capacitor after soldering to prevent excessive stress on the lead wires where they enter the seal.
- (2). Do not use capacitor as a handle when moving the circuit board assembly.
- (3). Avoid striking the capacitor after assembly to prevent failure due to excessive shock.

**2.7 Circuit Board Cleaning**

- (1) Circuit boards can be immersed or ultrasonically cleaned using suitable cleaning solvents for up to 5 minutes and up to 60°C maximum temperatures. The boards should be thoroughly rinsed and dried. The use of ozone depleting cleaning agents is not recommended in the interest of protecting the environment.
- (2) Avoid using the following solvent groups unless specifically allowed for in the specification;
  - Halogenated cleaning solvents: except for solvent resistant capacitor types, halogenated solvents can permeate the seal and cause internal capacitor corrosion and failure. For solvent resistant capacitors, carefully follow the temperature and time requirements of the specification. 1-1-1 trichloroethane should never be used on any aluminum electrolytic capacitor.
  - Alkali solvents : could attack and dissolve the aluminum case.
  - Petroleum based solvents: deterioration of the rubber seal could result.
  - Xylene : deterioration of the rubber seal could result.
  - Acetone : removal of the ink markings on the vinyl sleeve could result.
- (3) A thorough drying after cleaning is required to remove residual cleaning solvents which may be trapped between the capacitor and the circuit board. Avoid drying temperatures, which exceed the maximum rated temperature of the capacitor.
- (4) Monitor the contamination levels of the cleaning solvents during use by electrical conductivity, pH, specific gravity, or water content. Chlorine levels can rise with contamination and adversely affect the performance of the capacitor. Please consult us for additional information about acceptable cleaning solvents or cleaning methods.

**2.8 Mounting Adhesives and Coating Agents**

When using mounting adhesives or coating agents to control humidity, avoid using materials containing halogenated solvents. Also, avoid the use of chloroprene based polymers. After applying adhesives or coatings, dry thoroughly to prevent residual solvents from being trapped between the capacitor and the circuit board.

**3. Precautions for using capacitors**

**3.1 Environmental Conditions**

Capacitors should not be stored or used in the following environments.

- (1) Temperature exposure above the maximum rated or below the minimum rated temperature of the capacitor.
- (2) Direct contact with water, salt water, or oil.
- (3) High humidity conditions where water could condense on the capacitor.
- (4) Exposure to toxic gases such as hydrogen sulfide, sulfuric acid, nitric acid chlorine, or ammonia.
- (5) Exposure to ozone, radiation, or ultraviolet rays.
- (6) Vibration and shock conditions exceeding specified requirements.

**3.2 Electrical Precautions**

- (1) Avoid touching the terminals of the capacitor as possible electric shock could result. The exposed aluminum case is not insulated and could also cause electric shock if touched.
- (2) Avoid short circuit the area between the capacitor terminals with conductive materials including liquids such as acids or alkaline solutions.

**4. Emergency Procedures**

- (1) If the pressure relief vent of the capacitor operates, immediately turn off the equipment and disconnect from the power source. This will minimize additional damage caused by the vaporizing electrolyte.
- (2) Avoid contact with the escaping electrolyte gas which can exceed 100°C temperatures.
  - If electrolyte or gas enters the eye, immediately flush the eyes with large amounts of water.
  - If electrolyte or gas is ingested by mouth, gargle with water.
  - If electrolyte contacts the skin, wash with soap and water.

**5. Long Term Storage**

Leakage current of a capacitor increases with long storage times. The aluminum oxide film deteriorates as a function of temperature and time. If used without reconditioning, an abnormally high current will be required to restore the oxide film. This current surge could cause the circuit or the capacitor to fail. After one year, a capacitor should be reconditioned by applying rated voltage in series with a 1000Ω, current limiting resistor for a time period of 30 minutes. If the expired date of products date code is over eighteen months, the products should be return to confirmation.

**5.1 Environmental Conditions**

Version	01	Page	14
---------	----	------	----

<b>MAN YUE ELECTRONICS COMPANY LIMITED</b>	<i>ELECTROLYTIC CAPACITOR SPECIFICATION KM SERIES</i>	<b>SAMXON</b>

The capacitor shall be not use in the following condition:

- (1) Temperature exposure above the maximum rated or below the minimum rated temperature of the capacitor.
- (2) Direct contact with water, salt water, or oil.
- (3) High humidity conditions where water could condense on the capacitor.
- (4) Exposure to toxic gases such as hydrogen sulfide, sulfuric acid, nitric acid, chlorine, or ammonia.
- (5) Exposure to ozone, radiation, or ultraviolet rays.
- (6) Vibration and shock conditions exceeding specified requirements.

**6. Capacitor Disposal**

When disposing of capacitors, use one of the following methods.

Incinerate after crushing the capacitor or puncturing the can wall (to prevent explosion due to internal pressure rise).

Capacitors should be incinerated at high temperatures to prevent the release of toxic gases such as chlorine from the polyvinyl chloride sleeve, etc.

Dispose of as solid waste.

NOTE: Local laws may have specific disposal requirements, which must be followed.



## X-ON Electronics

Largest Supplier of Electrical and Electronic Components

*Click to view similar products for [Aluminum Electrolytic Capacitors - Leaded](#) category:*

*Click to view products by [Man Yue](#) manufacturer:*

Other Similar products are found below :

[LXY50VB4.7M-5X11](#) [MAL203125221E3](#) [MAL204216159E3](#) [ESMG101ETD100MF11S](#) [RBC-25V-10UF-4X7](#) [RE3-35V222MJ6#](#) [RFO-100V471MJ7P#](#) [B41041A2687M8](#) [B41041A7226M8](#) [B41044A7157M6](#) [EKRG250ELL100MD07D](#) [EKXG201EC3101ML20S](#)  
[EKXG351ETD6R8MJ16S](#) [EKZM160ETD471MHB5D](#) [EPA-201ELL151MM25S](#) [NCD681K10KVY5PF](#) [NRLF103M25V35X20F](#)  
[KM4700/16](#) [KME50VB100M-8X11.5](#) [RXJ222M1EBK-1625](#) [SG220M1CSA-0407](#) [ES5107M016AE1DA](#) [ESX472M16B](#) [MAL211929479E3](#)  
[40D506F050DF5A](#) [TE1202E](#) [36DA273F050BB2A](#) [KME25VB100M-6.3X11](#) [511D336M250EK5D](#) [511D337M035CG4D](#)  
[515D477M035CG8PE3](#) [052687X](#) [EKMA500ELL4R7ME07D](#) [EKRG100ETC221MF09D](#) [NRE-S560M16V6.3X7TBSTF](#)  
[ERZA630VHN182UP54N](#) [MAL214099813E3](#) [MAL211990518E3](#) [MAL204281229E3](#) [NEV680M35EF](#) [686KXM050M](#) [ERS1VM222L30OT](#)  
[EGW2GM150W16OT](#) [EGS2GM6R8G12OC](#) [EHS2GM220W20OT](#) [ERF1VM222L30OT](#) [ERF1KM151G20OT](#) [EKZE500ELL101MHB5D](#)  
[EKMM251VSN221MP25S](#) [RGA221M1HBK-1016G](#)