

SLD70R900S2 / SLF70R900S2

700V N-Channel Power MOSFET

General Description

This Power MOSFET is produced using Maple semi's advanced planar stripe DMOS technology. This advanced technology has been especially tailored to minimize on-state resistance, provide superior switching performance, and withstand high energy pulse in the avalanche and commutation mode. These devices are well suited for high efficiency switched mode power supplies, active power factor correction based on half bridge topology

Features

- 5A, 700V, $R_{DS(on) typ.} = 0.8\Omega @ V_{GS} = 10V$
- Extended Safe Operating Area
- Ease of Paralleling
- Fast Switching
- 100% avalanche tested
- 100% Single Pulse avalanche energy Test

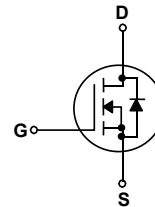
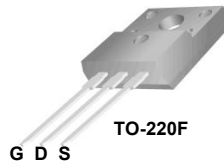
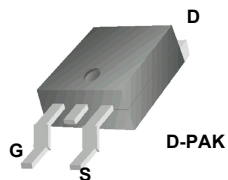

Absolute Maximum Ratings

Symbol	Parameter	SLF70R900S2	SLD70R900S2	Units
V_{DSS}	Drain-to-Source Breakdown Voltage	700		V
I_D	Drain Current - Continuous ($T_C = 25^\circ C$)	5		A
	Drain Current - Continuous ($T_C = 100^\circ C$)	3.2		A
I_{DM}	Drain Current - Pulsed	18		A
V_{GS}	Gate-Source Voltage	± 30		V
P_{tot}	Power Dissipation ($T_C = 25^\circ C$)	24	58	W
T_J	Operating Junction Temperature Range	-55 to +150		$^\circ C$
EAS	Single Pulsed Avalanche Energy (Note 2)	180		mJ

Electrical Characteristics @ $T_J=25^\circ C$ (unless otherwise specified)

Symbol	Parameter	Test Conditions	Min.	Typ.	Max.	Unit
VDS	Drain-source Voltage	$V_{GS} = 0V, I_D = 250\mu A$	700			V
$R_{DS(on)}$	Static Drain-to-Source on-Resistance	$V_{GS} = 10V, I_D = 20A$		0.8	0.9	Ω
$V_{GS(th)}$	Gated Threshold Voltage	$V_{DS} = V_{GS}, I_D = 250\mu A$	2.0	3.0	4.0	V

IDSS	Zero Gate Voltage Drain Current	VDS=100V, VGS = 0V			1.0	μA
IGSS(F)	Gated Body Leakage Current	VGS = +30V,			100	nA
IGSS(R)	Gated Body Leakage Current	VGS = -30V,			-100	nA
Ciss	Input Capacitance	VGS =0V, VDS=25V, f=1.0MHZ			360	pF
Coss	Output Capacitance				21	pF
Crss	Reverse Transfer Capacitance				1.9	pF
Qg	Total Gate Charge		VDS=560V			19.2
Qgs	Gate-Source Charge	ID=5A			2.45	nC
Qgd	Gate-Drain Charge	VGS=10V			11.7	nC
t _{d(on)}	Turn-on Delay Time	VDD=350V, ID=5A			9.47	nS
t _r	Turn-on Rise Time				26.3	nS
t _{d(off)}	Turn-off Delay Time	VGS=10V, RG=24Ω			57.9	nS
t _f	Turn-off Fall Time				25.7	nS

Source-Drain Diode Maximum Ratings and Characteristics

Symbol	Parameter	Test Conditions	Min.	Typ.	Max.	Unit
I _{SD}	S-D Current(Body Diode)				5	A
I _{SDM}	Pulsed S-D Current(Body Diode)				18.0	A
VSD	Diode Forward Voltage	VGS =0V, IDS=5A			1.4	V
t _{rr}	Reverse Recovery Time	T _J =25°C, I _F =5A di/dt=100 A/us		305		nS
Q _{rr}	Reverse Recovery Charge			2.3		nC
*Pulse Test: Pulse Width≤300μs, Duty Cycle≤2%						

Thermal Resistance

Symbol	Parameter	Typ.	Max.	Units
RθJC	Junction-to-Case		5.21	°C/W
RθJA	Junction-to-Ambient		62.5	°C/W

Notes:

1. Repetitive Rating : Pulse width limited by maximum junction temperature
2. L = 79mH, IAS = 2.0A, VDD =100V, RG = 25Ω, Starting T_J = 25° C
3. ISD 5.0A, di/dt 100A/us, VDD BVDSS, Starting T_J = 25° C
4. Pulse Test : Pulse width 300us, Duty cycle 2%
5. Essentially independent of operating temperature

Typical Characteristics

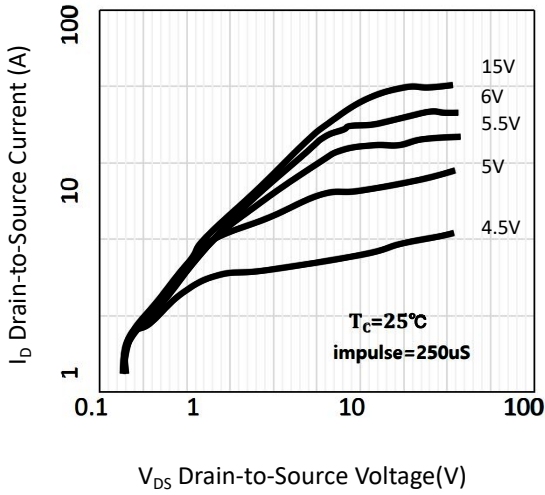

Figure 1. Typical Output Characteristics

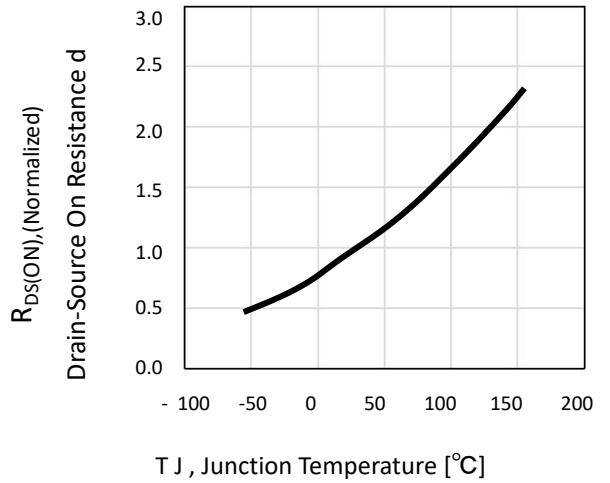

Figure 2. Typical Output Characteristics

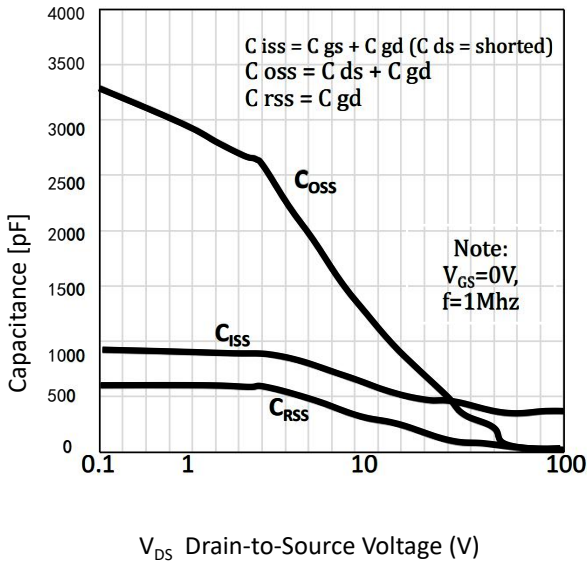

Figure 3. Typical Capacitance Vs Drain-Source Voltage

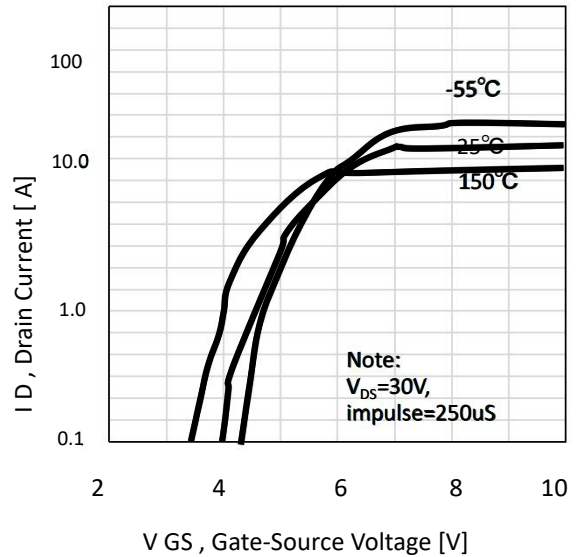

Figure 4. On-Resistance Vs Drain Current

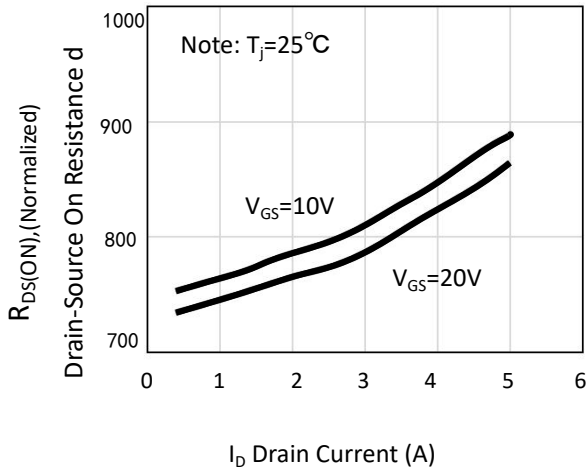

Figure 5. $R_{DS(ON)}$ Vs Drain Current , Gate-Source Voltage

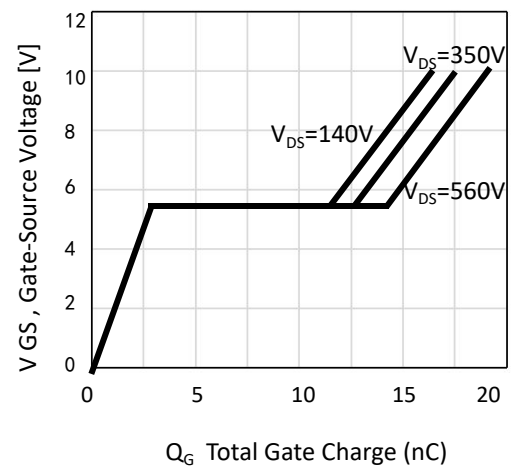

Figure 6. Typical Gate Charge Vs Gate-Source Voltage

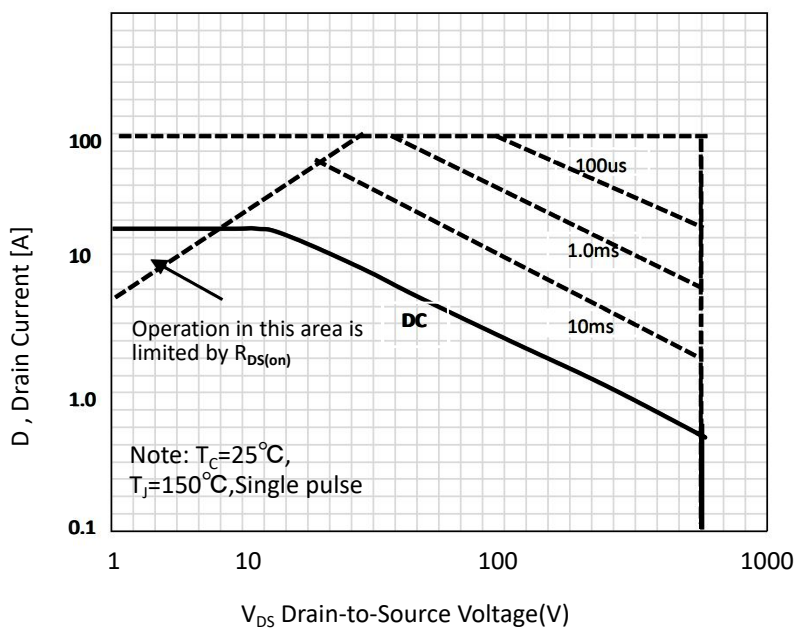

Figure 7. Maximum Safe Operating Area

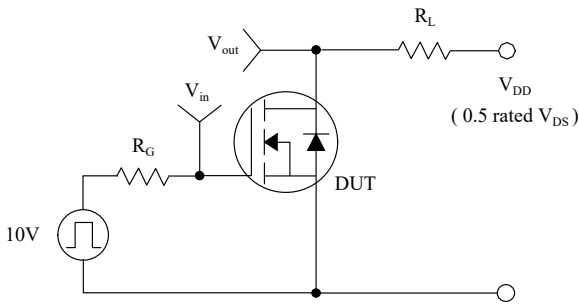

Figure 8 a. Switching Time Test Circuit

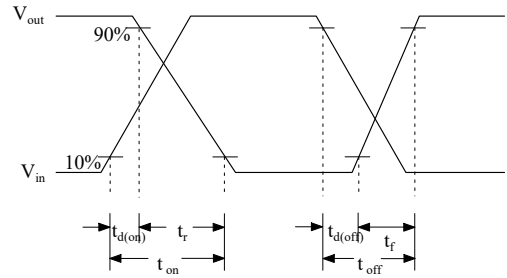

Figure 8 b. Switching Time Waveforms

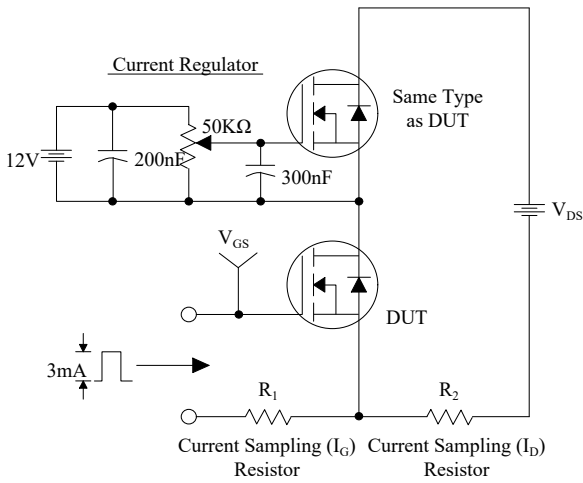

Figure 9 a. Gate Charge Test Circuit

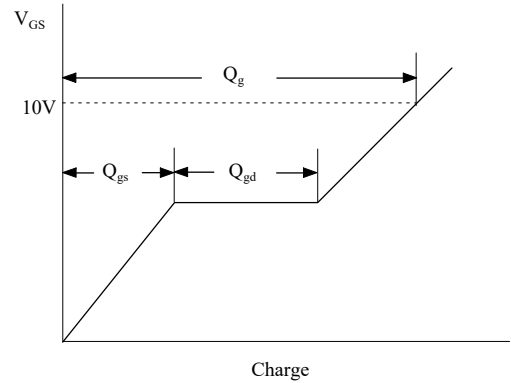

Figure 9 b. Basic Gate Charge Waveforms

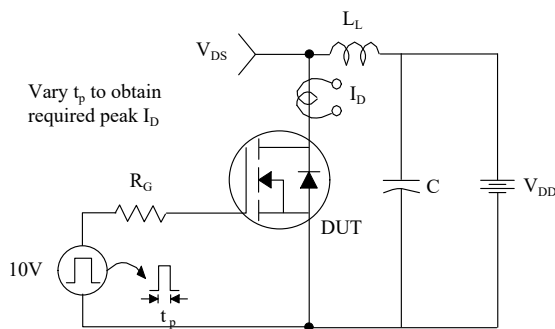

Figure 10 a. Unclamped Inductive Switching Test Circuit

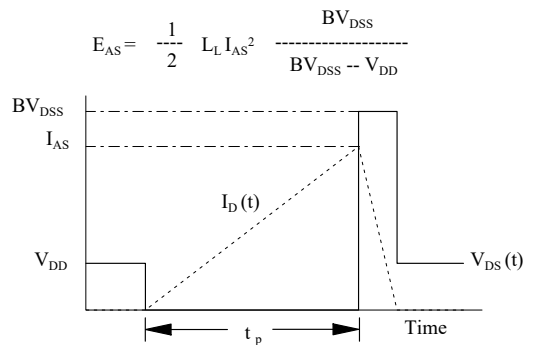

Figure 10 b. Switching Test Waveforms

X-ON Electronics

Largest Supplier of Electrical and Electronic Components

Click to view similar products for [MOSFET](#) category:

Click to view products by [Maplesemi](#) manufacturer:

Other Similar products are found below :

[614233C](#) [648584F](#) [MCH3443-TL-E](#) [MCH6422-TL-E](#) [FDPF9N50NZ](#) [FW216A-TL-2W](#) [FW231A-TL-E](#) [APT5010JVR](#) [NTNS3A92PZT5G](#)
[IRF100S201](#) [JANTX2N5237](#) [2SK2464-TL-E](#) [2SK3818-DL-E](#) [FCA20N60_F109](#) [FDZ595PZ](#) [STD6600NT4G](#) [FSS804-TL-E](#) [2SJ277-DL-E](#)
[2SK1691-DL-E](#) [2SK2545\(Q,T\)](#) [D2294UK](#) [405094E](#) [423220D](#) [MCH6646-TL-E](#) [TPCC8103,L1Q\(CM](#) [367-8430-0972-503](#) [VN1206L](#)
[424134F](#) [026935X](#) [051075F](#) [SBVS138LT1G](#) [614234A](#) [715780A](#) [NTNS3166NZT5G](#) [751625C](#) [873612G](#) [IRF7380TRHR](#)
[IPS70R2K0CEAKMA1](#) [RJK60S3DPP-E0#T2](#) [RJK60S5DPK-M0#T0](#) [APT5010JVFR](#) [APT12031JFLL](#) [APT12040JVR](#) [DMN3404LQ-7](#)
[NTE6400](#) [JANTX2N6796U](#) [JANTX2N6784U](#) [JANTXV2N5416U4](#) [SQM110N05-06L-GE3](#) [SIHF35N60E-GE3](#)