



3Northway Lane North Latham, New York 12110.

Tollfree:1.800.984.5337

Phone:1.518.956.2980

Fax:1.518.785.4725

Http://www.marktechopto.com

SPECIFICATION

PART NO. : MT2030-HRG-A

3.0mm ROUND BI-POLAR LAMP (2 LEADS)



Description

This green and orange bi-color lamp is made with GaP/GaP green chip, GaAsP/GaP orange chip and white diffused epoxy resin.

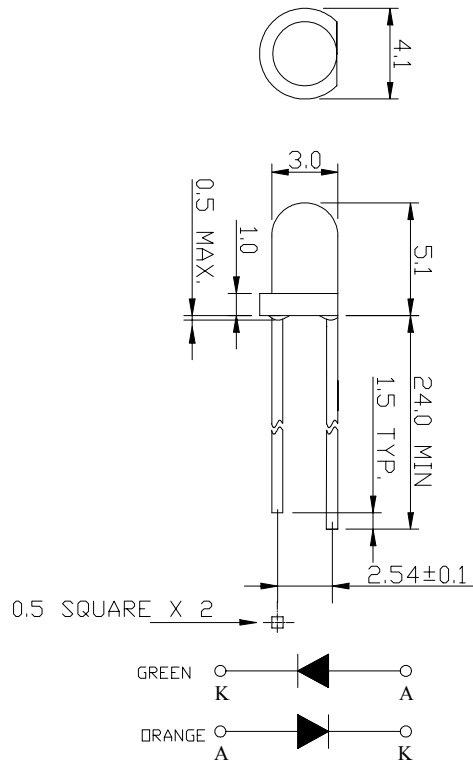

Notes:

1. ALL DIMENSIONS ARE IN mm.
2. TOLERANCE IS±0.25mm UNLESS OTHERWISE NOTED.

Description

Part No.	LED Chip		Lens Color
	Material	Emitting Color	
MT2030-HRG-A	GaP/GaP	Green	White diffused
	GaAsP/GaP	Red	

Absolute Maximum Ratings at Ta=25

Parameter	Symbol	Rating	Unit
Power Dissipation	P _D	78	mW
Reverse Voltage	V _R	5	V
D.C. Forward Current	I _f	30	mA
Reverse (Leakage) Current	I _r	100	μA
Peak Current(1/10Duty Cycle,0.1ms Pulse Width.)	I _f (Peak)	100	mA
Operating Temperature Range	T _{opr.}	-25 to +85	
Storage Temperature Range	T _{stg.}	-40 to +100	
Lead Soldering Temp.(1.6mm from body) for 5 seconds		260	

Electrical and Optical Characteristics:
Green

Parameter	Symbol	Condition	Min.	Typ.	Max.	Unit
Luminous Intensity	I _v	I _f =20mA	3.0	7.0		mcd
Forward Voltage	V _f	I _f =20mA		2.1	2.6	V
Peak Wavelength	λ _P	I _f =20mA		567		nm
Dominant Wavelength	λ _D	I _f =20mA		572		nm
Reverse (Leakage) Current	I _r	V _r =5V			100	μA
Viewing Angle	2 1/2	I _f =20mA		118		deg
Spectrum Line Halfwidth	Δλ	I _f =20mA		30		nm

NOTE: THE DATAS TESTED BY IS TESTER

Absolute Maximum Ratings at Ta=25

Parameter	Symbol	Rating	Unit
Power Dissipation	P _D	78	mW
Reverse Voltage	V _R	5	V
D.C. Forward Current	I _f	30	mA
Reverse (Leakage) Current	I _r	100	μ A
Peak Current(1/10Duty Cycle,0.1ms Pulse Width.)	I _f (Peak)	100	mA
Operating Temperature Range	T _{opr.}	-25 to +85	
Storage Temperature Range	T _{stg.}	-40 to +100	
Lead Soldering Temp.(1.6mm from body) for 5 seconds		260	

Electrical and Optical Characteristics:
R e d

Parameter	Symbol	Condition	Min.	Typ.	Max.	Unit
Luminous Intensity	I _v	I _f =20mA	4.29	9.0		mcd
Forward Voltage	V _f	I _f =20mA		2.1	2.6	V
Peak Wavelength	λ _P	I _f =20mA		635		nm
Dominant Wavelength	λ _D	I _f =20mA		626		nm
Reverse (Leakage) Current	I _r	V _r =5V			100	μA
Viewing Angle	2 1/2	I _f =20mA		118		deg
Spectrum Line Halfwidth	Δλ	I _f =20mA		35		nm

NOTE: THE DATAS TESTED BY IS TESTER

Typical Electrical / Optical Characteristics Curves :

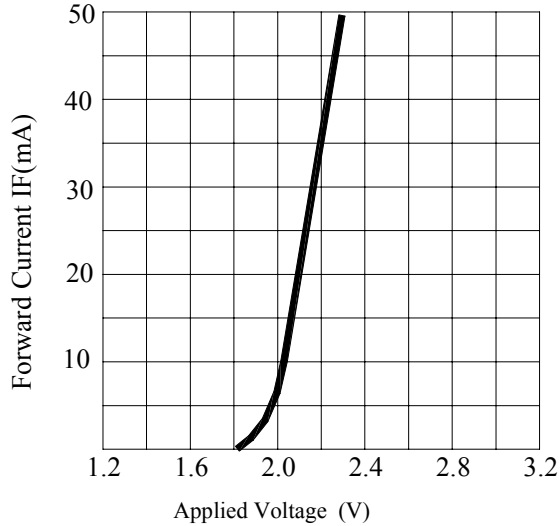

FORWARD CURRENT VS. APPLIED VOLTAGE

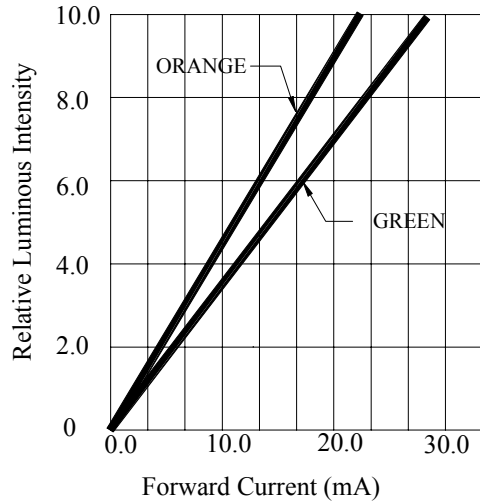

FORWARD CURRENT VS. LUMINOUS INTENSITY

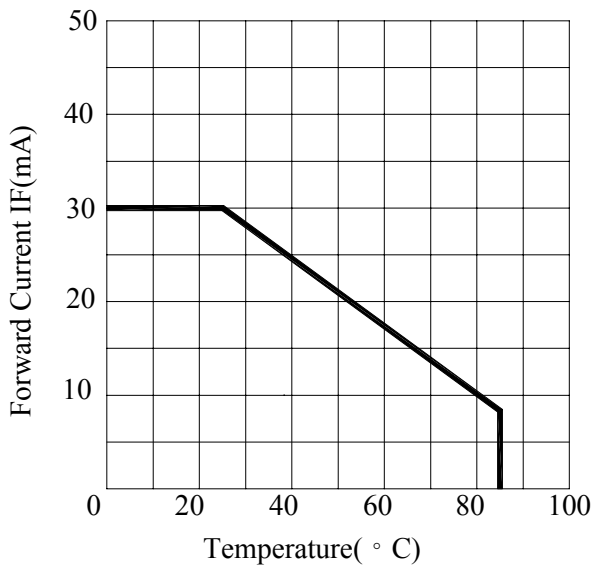

FORWARD CURRENT VS. AMBIENT TEMPERATURE

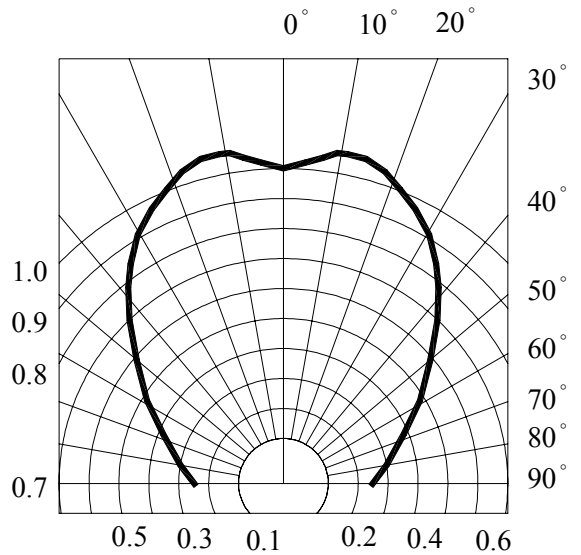

RADIATION DIAGRAM

Precautions:

TAKE NOTE OF THE FOLLOWING IN USE OF LED

1. Temperature in use

Since the light generated inside the LED needs to be emitted to outside efficiently, a resin with high light transparency is used; therefore, additives to improve the heat resistance or moisture resistance (silica gel, etc) which are used for semiconductor products such as transistors cannot be added to the resin.

Consequently, the heat resistant ability of the resin used for LED is usually low; therefore, please be careful on the following during use.

Avoid applying external force, stress, and excessive vibration to the resins and terminals at high temperature. The glass transition temperature of epoxy resin used for the LED is approximately 120-130 .

At a temperature exceeding this limit, the coefficient of linear expansion of the resin doubles or more compared to that at normal temperature and the resin is softened.

If external force or stress is applied at that time, it may cause a wire rupture.

2. Soldering

Please be careful on the following at soldering.

After soldering, avoid applying external force, stress, and excessive vibration until the products go to cooling process (normal temperature), <Same for products with terminal leads>

(1) Soldering measurements:

Distance between melted solder side to bottom of resin shall be 1.6mm or longer.

(2) Solder dip: Preheat: 90 max. (Backside of PCB), Within 120 seconds

Solder bath: 250 max. (Solder temperature), Within 5 seconds

(3) Soldering iron : 250 max. (Temperature of soldering iron tip), Within 3 seconds

3. Insertion

Pitch of the LED leads and pitch of mounting holes need to be same

4. Others

Since the heat resistant ability of the LED resin is low, SMD components are used on the same PCB, please mount the LED after adhesive baking process for SMD components. In case adhesive baking is done after LED lamp insertion due to a production process reason, make sure not to apply external force, stress, and excessive vibration to the LED and follow the conditions below.

Baking temperature: 120 max. Baking time: Within 60 seconds

If soldering is done sequentially after the adhesive baking, please perform the soldering after cooling down the LED to normal temperature.

X-ON Electronics

Largest Supplier of Electrical and Electronic Components

Click to view similar products for [Standard LEDs - Through Hole category](#):

Click to view products by [Marktech manufacturer](#):

Other Similar products are found below :

[LTL-10254W](#) [LTL-1214A](#) [LTL-2231AT](#) [LTL-3251A](#) [LTL-4262N](#) [LTL-433P](#) [LTL-5234](#) [LTL87HTBK](#) [LTL-87HD4B](#) [HLMP-EL30-PS0DD](#) [1L0532V23G0TD001](#) [NSPW500CS](#) [LD CQDP-1U3U-W5-1-K](#) [LP379PPG1C0G0300001](#) [SLR-342MC3F](#) [SLX-LX3044GD](#) [SLX-LX3044ID](#) [SLX-LX3044YD](#) [1.90690.3330000](#) [SSS-LX4673ID-410B](#) [1L0532Y24I0TD001](#) [264-7SYGD/S530-E2](#) [HLMP-1301-G00FG](#) [HLMP1385](#) [LTL-10224W](#) [LTL-1224A](#) [LTL-1234A](#) [LTL-2251AT](#) [LTL-403HR](#) [LTL-4222](#) [LU7-E-B](#) [4380H1](#) [HLMP-3962-F0002](#) [HLMP-GG15-R0000](#) [L53SRC/E-Z](#) [L-7679C1ZGC](#) [4302T1-5V](#) [4306D23](#) [4363D1/5](#) [WP1503SRC/J4](#) [WP153YDT](#) [WP1543SGC](#) [WP1543SRC/D](#) [WP1543SURC](#) [WP53MGD](#) [WP7113HD](#) [WP7113MBD](#) [WP7113MGC](#) [WP7143SEC/H](#) [Z-221A](#)