

Fig. 3.: Diagrams of the operation principles of the TS-41-2 TWILIGHT SWITCH.

V. Repair and maintenance

All repairs of the TWILIGHT SWITCH TS-41-2 are performed by the manufacturer. The device does not require any maintenance. When the sensor becomes contaminated, clean it with a clean, damp cloth. The device does not require any additional maintenance.

VI. Warranty Card

The manufacturer guarantees the correct operation of the TS-41-2 TWILIGHT SWITCH. The warranty period is 36 months from the date of sale. The warranty is extended by the time of repair. Warranty repairs are performed by the manufacturer free of charge after the AUTOMAT is delivered to the manufacturer. Improper use of the device or independent modifications to it will void the warranty.



www.mart-electronics.eu

Made in Europe



The TS-41-2 TWILIGHT SWITCH meets the requirements of the European Union Directives
 - Directive LVD 2014/35/EU - Low Voltage Directive of 26 February 2014
 - Directive EMC 2014/30/EU - Electromagnetic Compatibility Directive of 26 February 2014



In order to protect the environment, do not throw away used electrical appliances and electronics together with municipal waste. Used equipment should be delivered to collection points for recycling free of charge. Any information on this can be obtained at sellers, distributors, manufacturer or on the Internet. The product's packaging is made of ecological materials. The PVC packaging tape will be used while stocks last.



MADE IN EUROPE

TWILIGHT SWITCH
TS-41-2



3-YEAR
WARRANTY



User manual

I. Purpose

The TS-41-2 TWILIGHT SWITCH is designed to automatically switch the receiver on at dusk and switch it off at dawn, or vice versa (NO, NC contacts). The receivers can be: outdoor lighting of buildings, street lighting, lighting of exhibitions, shop windows, various types of advertisements, drivers in the systems of closing and opening roller shutters, window blinds and other receivers turned on at sunset and turned off at sunrise or vice versa.

The TWILIGHT SWITCH consists of:

- >> TS-41 CONTROLLER - mounted in a distribution box on a 35 mm rail (one 18 mm module)
- >> OUTDOOR SENSOR - designed for installation in the housing of the distribution box.
 OUTDOOR SENSOR (IP65) - diameter 9.9 mm and length 35 mm, with a nut for quick assembly, made of polycarbonate with a 1m long cable (you can extend the cable up to 100m).
 The SENSOR has characteristics similar to those of the human eye.

II. Properties of the TS-41-2 TWILIGHT AUTOMATIC

- >> High switching power 16A (4000 W) 250VAC, 16A (384 W) 24VDC
 - >> high inrush current (resistance to 100 A surge current)
 - >> freedom of connections:
 - > executive relay contacts (one normally open contact - NO, one normally closed contact - NC) galvanically separated, which allows connections in various configurations
 - >> precise logarithmic regulation (characteristics similar to that of the human eye):
 - > 1 ... 10 lx - energy-saving range
 - > 10 ... 100 lx - standard range
 - > 100 ... 1000 lx - range of switching receivers on (off) with high light intensity
 - >> proportional hysteresis depending on the illuminance
 - >> traffic light (LED) on the front panel of the TS-41 CONTROLLER, informing about the operating status:
 - > Green LED - indication of 230V supply voltage on LN terminals
 - > LED red flashing - signaling (without delay) of exceeding the set (adjustable) illuminance threshold
 - > Blue LED - changeover indication - switching on (contact 1-2), disconnection (contact 2-3)
 - >> 35mm rail mount - one 18mm module.
- The TS-41 CONTROLLER uses a specialized OMRON G2RL-1-E-HR relay, designed to switch various lighting lamps. The special design enables effective switching of lamps with a starting current up to 100 A.

III. Assembly

The TS-41-2 TWILIGHT SWITCH device may only be connected by a person authorized to operate electrical installations. Remember to choose the right protection.

On the front panel of the TS-41 CONTROLLER, there are three information LEDs: green and red and blue and a knob for setting the activation threshold in the range from 1 to 1000 lux. On the side panels On the TS-41 CONTROLLER, there are connection diagrams and regulation characteristics.

In order to connect the TS-41-2 TWILIGHT SWITCH SYSTEM you should:

1. mount the TS-41 CONTROLLER in the switchboard on a 35 mm rail
2. mount the SENSOR using the special "CLICK" nut. The nut is designed to allow quick assembly. It has two zones I and II (Fig. 1). A hole must be drilled in the switch box with a diameter of 10 mm in a place lit by daylight. The wall thickness of the switch box cannot exceed 25 mm. After installing the SENSOR in the hole, push the nut on the SENSOR into zone I and after moving it along the SENSOR to the wall of the distribution box, push the nut into zone II. In zone II, the "CLICK" nut has a thread, so it can be screwed onto the wall of the distribution box

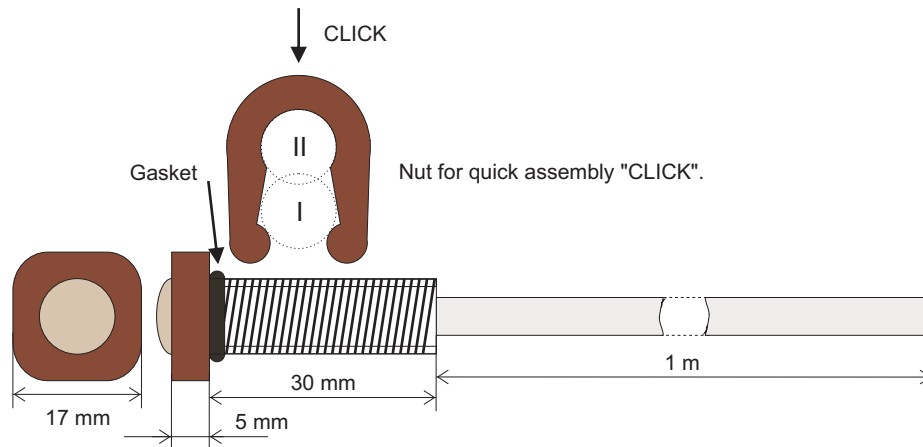

Fig. 1. Photosensitive sensor - design and dimensions.

3. Connect the wires in accordance with the diagram (Fig. 2)
4. turn on the supply voltage - the green LED will light up and the red and blue LEDs will blink once
5. set the threshold.

When the level set on the knob is exceeded, a blinking red LED will light (without delay), and after approx. 60 seconds the operating relay will switch, which will be signaled by a blue LED.

Using the fine adjustment, set the desired switch-on threshold value. Check operation of the TS-41-2 TWILIGHT SWITCH device and possibly correct the setting in real conditions (in the evening and in the morning).

It should be remembered that the optimal setting of the activation threshold affects the costs of the electricity used. The most advantageous, from the point of view of energy efficiency, is to install the SENSOR on the east or south-east side, due to the early switching off of the receiver at dawn, which reduces the costs of electricity used and contributes to environmental protection.

In order to limit the impact of temporary large changes in lighting, e.g. car lamps, flash fleece, etc. for the operation of the TWILIGHT SWITCH, a delay of about 60s has been applied.

The TWILIGHT SWITCH TS-41-2 uses a proportional hysteresis so that the TWILIGHT SWITCH does not switch along with the changing lighting on cloudy days.

When setting low illuminance values (less than 100 lux), remember that on a sunny day, covering the sensor with your bare hand may not be sufficient. Then the SENSOR should be covered more effectively.

Schematic diagrams of the operation principle of the TS-41-2 TWILIGHT SWITCH is presented in Fig. 3.

NOTE: Avoid mounting the SENSOR directly in the light beam of the lamp, because lighting with the SENSOR lamp may interfere with its operation - the lamp will cyclically turn on and off from evening until morning.

IV. Technical data

Rated supply voltage LN	230V AC, + 10%, - 15%
Rated frequency	50Hz
Maximum load current (power):	
> resistive load	16A, AC1 (4 000 W)
> incandescent lamps	10A (2500 W)
> halogen lamps	8A (2000 W)
> fluorescent lamps	8A (2000 W)
> energy-saving lamps and LED	8A (2000 W)
Instantaneous inrush current	100A
Executive contacts	1 x NO, 1 x NC
Rated power consumption	0,7 W
Logarithmic control range	1...10...100...1000 lx
Hysteresis	$E_{OFF} = 2E_{ON}$
Switch-on and switch-off delay	60s ($\pm 10\%$)
Mechanical durability	100 000 operations
CONTROLLER protection level	
CONTROLLER protection level	IP 20
Installation of the CONTROLLER	
Installation of the CONTROLLER	One 18 mm field, 35 mm rail
CONTROLLER work position	
CONTROLLER work position	Vertical
CONTROLLER working temperature	
CONTROLLER working temperature	-25...+50 °C
CONTROLLER weight	
CONTROLLER weight	50g
SENSOR protection class	
SENSOR protection class	IP 65
SENSOR hole	
SENSOR hole	$\phi 10$
SENSOR assembly	
SENSOR assembly	„CLICK“ nut, gasket
SENSOR working position	
SENSOR working position	Vertical
Cable length to the SENSOR	
Cable length to the SENSOR	Max 100 m (2 x 0,5 mm ²)
SENSOR working temperature	
SENSOR working temperature	-25...+50 °C
SENSOR weight	
SENSOR weight	20g

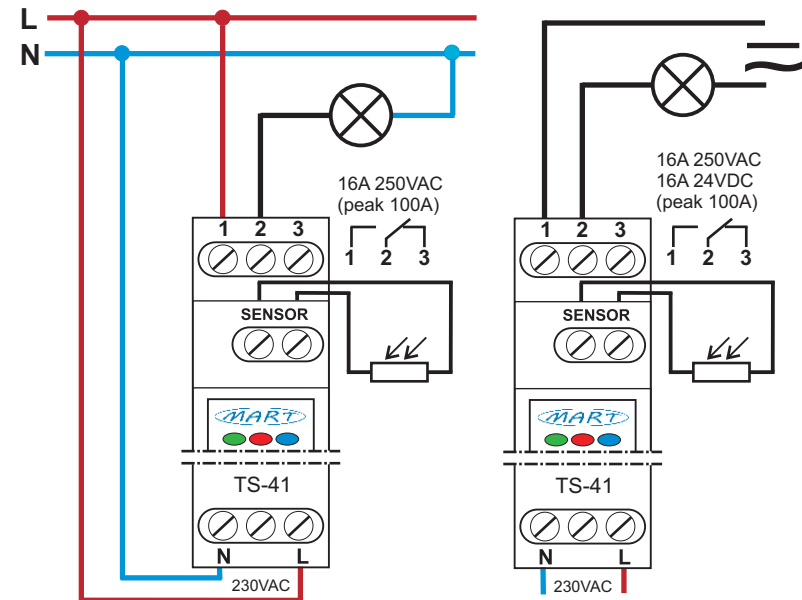

Fig. 2. : Connection diagrams for the TS-41-2 TWILIGHT SWITCH automatic device.

X-ON Electronics

Largest Supplier of Electrical and Electronic Components

Click to view similar products for [Controllers](#) category:

Click to view products by [MART](#) manufacturer:

Other Similar products are found below :

[61FGPN8DAC120](#) [CV500SLK21](#) [70177-1011](#) [F03-03 HAS C](#) [F03-31](#) [81550401](#) [FT1A-C12RA-W](#) [H2CAC24A](#) [H2CRSAC110B](#) [R88A-CRGB003CR-E](#) [R88ARR080100S](#) [R88A-TK01K](#) [DCN1-1](#) [AFP0RT32CT](#) [DRT2ID08C](#) [DTB4896VRE](#) [DTB9696LVE](#) [E53-AZ01](#) [E53E01](#) [E53E8C](#) [E5C4Q40J999FAC120](#) [E5CWLQ1TCAC100240](#) [E5GNQ03PFLKACDC24](#) [B300LKL21](#) [NSCXDC1V3](#) [NSH5-232CW-3M](#) [NT20SST122BV1](#) [NV-CN001](#) [OAS-160-N](#) [C40PEDRA](#) [K31S6](#) [K33-L1B](#) [K3MA-F 100-240VAC](#) [K3TX-AD31A](#) [89750101](#) [L595020](#) [SRM1-C02](#) [SRS2-1](#) [G32X-V2K](#) [26546803](#) [26546805](#) [PWRA440A](#) [CPM1AETL03CH](#) [CV500SLK11](#) [3G2A5BI081](#) [3G2A5IA122](#) [3G2A5LK010E](#) [3G2A5OA223](#) [3G2A5OD211](#) [3G2A5PS223E](#)