

Fig. 3.: Diagrams of the operation principles of the TS-41-3.3 TWILIGHT SWITCH.

V. Repair and maintenance

All repairs of the TWILIGHT SWITCH TS-41-3.3 are performed by the manufacturer. The device does not require any maintenance. When the sensor becomes contaminated, clean it with a clean, damp cloth. The device does not require any additional maintenance.

VI. Warranty Card

The manufacturer guarantees the correct operation of the TS-41-3.3 TWILIGHT SWITCH. The warranty period is 36 months from the date of sale. The warranty is extended by the time of repair. Warranty repairs are performed by the manufacturer free of charge after the AUTOMAT is delivered to the manufacturer. Improper use of the device or independent modifications to it will void the warranty.



The TS-41-3.3 TWILIGHT SWITCH meets the requirements of the European Union Directives:
 - Directive LVD 2014/35/EU - Low Voltage Directive of 26 February 2014
 - Directive EMC 2014/30/EU - Electromagnetic Compatibility Directive of 26 February 2014



In order to protect the environment, do not throw away used electrical appliances and electronics together with municipal waste. Used equipment should be delivered to collection points for recycling free of charge. Any information on this can be obtained at sellers, distributors, manufacturer or on the Internet. The product's packaging is made of ecological materials. The PVC packaging tape will be used while stocks last.



TWILIGHT SWITCH
TS-41-3.3

MADE IN EUROPE



3-YEAR
WARRANTY



User manual

I. Purpose

The TS-41-3.3 TWILIGHT SWITCH is designed to automatically switch the receiver on at dusk and switch it off at dawn or vice versa (NO, NC contacts). The receivers can be: outdoor lighting of buildings, street lighting, lighting of exhibitions, windows, advertising of various types controllers in closing and opening systems of roller shutters, window blinds, and other switches on at sunset and off at sunrise or vice versa.

The TWILIGHT SWITCH includes:

- >> TS-41 CONTROLLER - mounted in a distribution box on a 35 mm rail (one 18 mm module)
- >> OUTDOOR SENSOR (IP65) - surface-mounted box mounted to the wall with two screws with PG9 gland to insert the cable. Connection cable not longer than 100m.

The SENSOR has characteristics similar to those of the human eye.

II. Properties of TWILIGHT SWITCH TS-41-3.3

- >> High switching power 16A (4000 W) 250VAC, 16A (384 W) 24VDC
 - >> high inrush current (resistance to 100 A surge current)
 - >> freedom of connections:
 - > executive relay contacts (one normally open contact - NO, one normally closed contact - NC) galvanically separated, which allows connections in various configurations
 - >> precise logarithmic regulation (characteristics similar to that of the human eye):
 - > 10 ... 100 lx - energy-saving interval, standard
 - > 100 ... 1000 lx - range of switching on / off advertising etc.
 - > 1000 ... 10,000 lx - range of switching on / off of blinds, roller shutters, solar panels, etc.
 - >> proportional hysteresis depending on the illuminance
 - >> traffic light (LED) on the front panel of the TS-41 CONTROLLER, informing about the operating status:
 - > Green LED - indication of 230V supply voltage on LN terminals
 - > LED red flashing - signaling (without delay) of exceeding the set (settable) illuminance threshold
 - > Blue LED - switching indication - switching on (contact 1-2), disconnection (contact 2-3)
 - >> 35mm rail mount - one 18mm module.
- The TS-41 CONTROLLER uses a specialized OMRON G2RL-1-E-HR relay, designed to switch various lighting lamps. The special design enables effective switching of lamps with a starting current up to 100 A.

III. Assembly

The TS-41-3.3 TWILIGHT SWITCH device may only be connected by a person authorized to operate electrical installations. Remember to choose the right protection.

On the front panel of the TS-41 CONTROLLER, there are three information LEDs: green and red and blue and a knob for setting the activation threshold in the range from 10 to 10 000 lux. On the side panels On the TS-41 CONTROLLER, there are connection diagrams and regulation characteristics.

In order to connect the TS-41-3.3 TWILIGHT SWITCH:

1. mount the TS-41 CONTROLLER in the switchboard on a 35 mm rail
2. Fix the SENSOR on a vertical wall with two screws.

Lead the connection cable into the box from below through the PG9 gland and connect to the terminal block. After mounting and screwing Wires to the terminal strip, tightly screw the PG9 gland.

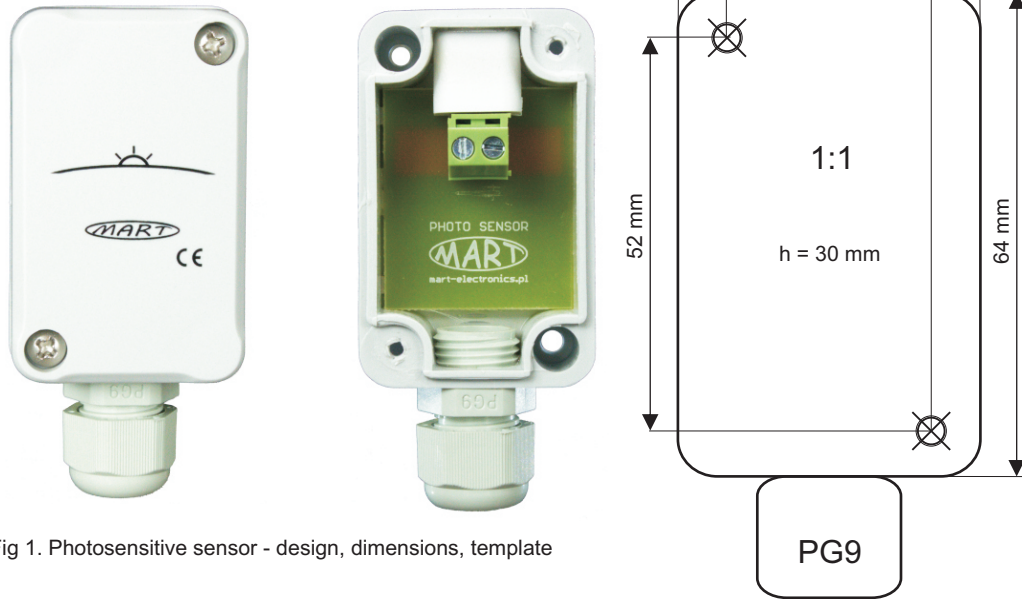

Fig 1. Photosensitive sensor - design, dimensions, template

3. Connect the wires in accordance with the diagram (fig. 2)
4. turn on the supply voltage - the green LED will light up and the red and blue LEDs will blink once
5. set the threshold.

When the current lighting level is exceeded, a blinking red LED will light (without delay), and after approx. 60 seconds the operating relay will switch, which will be signaled by a blue LED.

Using the fine adjustment, set the desired switch-on threshold value. Check operation of the TS-41-3.3 TWILIGHT SWITCH and, if necessary, correct the setting in real conditions (in the evening and in the morning).

It should be remembered that the optimal setting of the activation threshold affects the costs of the electricity used. The most advantageous, from the point of view of energy efficiency, is to install the SENSOR on the east or south-east side, due to the early switching off of the receiver at dawn, which reduces the costs of electricity used and contributes to environmental protection.

In order to limit the impact of temporary large changes in lighting, e.g. car lamps, a lightning flash, etc. on the operation of the TWILIGHT SWITCH, a delay of approx. 60 seconds has been applied.

The TWILIGHT SWITCH TS-41-3.3 uses a proportional hysteresis so that the SWITCH does not switch along with the changing lighting on cloudy days.

When setting low illuminance values (less than 100 lux), remember that

On a sunny day, covering the sensor with your bare hand may not be sufficient. Then the SENSOR should be covered more effectively.

Principle diagrams operation of the TS-41-3.3 TWILIGHT SWITCH is shown in Fig. 3.

NOTE: Avoid mounting the SENSOR directly in the light beam of the lamp, because lighting with the SENSOR lamp may interfere with operation - the lamp will turn on and off periodically from evening until morning.

IV. Technical data

| | |
|---------------------------------------|--------------------------------------|
| Rated supply voltage LN | 230V AC, + 10%, - 15% |
| Rated frequency | 50Hz |
| Maximum load current (power): | |
| > resistive load | 16A, AC1 (4 000 W) |
| > incandescent lamps | 10A (2500 W) |
| > halogen lamps | 8A (2000 W) |
| > fluorescent lamps | 8A (2000 W) |
| > energy-saving lamps and LED | 8A (2000 W) |
| Instantaneous inrush current | 100A |
| Executive contacts | 1 x NO, 1 x NC |
| Rated power consumption | 0,7 W |
| Logarithmic control range | 10...100...1 000...10 000 lx |
| Hysteresis | $E_{OFF} = 2E_{ON}$ |
| Switch-on and switch-off delay | 60s ($\pm 10\%$) |
| Mechanical durability | 100 000 operations |
| CONTROLLER protection level | |
| CONTROLLER protection level | IP 20 |
| Installation of the CONTROLLER | |
| Installation of the CONTROLLER | One 18 mm field, 35 mm rail |
| CONTROLLER work position | |
| CONTROLLER work position | Vertical |
| CONTROLLER working temperature | |
| CONTROLLER working temperature | -25...+50 °C |
| CONTROLLER weight | |
| CONTROLLER weight | 50g |
| SENSOR protection class | |
| SENSOR protection class | IP 65 |
| SENSOR dimensions | |
| SENSOR dimensions | 40mm x 30mm x 64mm + Pg9 |
| SENSOR assembly | |
| SENSOR assembly | Two screws |
| SENSOR working position | |
| SENSOR working position | Vertical |
| Cable length to the SENSOR | |
| Cable length to the SENSOR | Max 100 m (2 x 0,5 mm ²) |
| SENSOR working temperature | |
| SENSOR working temperature | -25...+50 °C |
| SENSOR weight | |
| SENSOR weight | 50g |

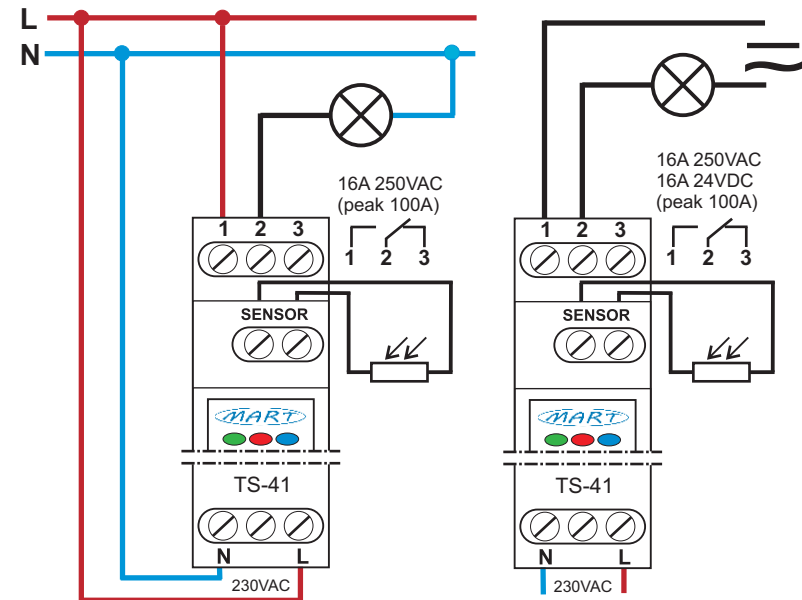

Fig. 2. : Connection diagrams for the TS-41-3.3 TWILIGHT SWITCH automatic device.

X-ON Electronics

Largest Supplier of Electrical and Electronic Components

Click to view similar products for [Controllers](#) category:

Click to view products by [MART](#) manufacturer:

Other Similar products are found below :

[61FGPN8DAC120](#) [CV500SLK21](#) [70177-1011](#) [F03-03 HAS C](#) [F03-31](#) [81550401](#) [FT1A-C12RA-W](#) [H2CAC24A](#) [H2CRSAC110B](#) [R88A-CRGB003CR-E](#) [R88ARR080100S](#) [R88A-TK01K](#) [DCN1-1](#) [AFP0RT32CT](#) [DRT2ID08C](#) [DTB4896VRE](#) [DTB9696LVE](#) [E53-AZ01](#) [E53E01](#) [E53E8C](#) [E5C4Q40J999FAC120](#) [E5CWLQ1TCAC100240](#) [E5GNQ03PFLKACDC24](#) [B300LKL21](#) [NSCXDC1V3](#) [NSH5-232CW-3M](#) [NT20SST122BV1](#) [NV-CN001](#) [OAS-160-N](#) [C40PEDRA](#) [K31S6](#) [K33-L1B](#) [K3MA-F 100-240VAC](#) [K3TX-AD31A](#) [89750101](#) [L595020](#) [SRM1-C02](#) [SRS2-1](#) [G32X-V2K](#) [26546803](#) [26546805](#) [PWRA440A](#) [CPM1AETL03CH](#) [CV500SLK11](#) [3G2A5BI081](#) [3G2A5IA122](#) [3G2A5LK010E](#) [3G2A5OA223](#) [3G2A5OD211](#) [3G2A5PS223E](#)