

Marvell Alaska 88E3082/88E3083

Integrated 8-Port 10/100BASE-T Fast Ethernet Transceivers



PRODUCT OVERVIEW

The Marvell® Alaska® 88E3082 and 88E3083 are third-generation Marvell DSP-based 8-port 10/100BASE-T Fast Ethernet (FE) transceivers. They offer the industry's lowest power consumption at only 150mW per port, resulting in higher port density, lower cost FE switches. Additionally, the 88E3082 and 88E3083 integrate the industry's most advanced FE transceiver feature set, such as Marvell's Virtual Cable Tester® (VCT™) technology for remote cable diagnostics and support for very low power modes.

The Alaska 88E3082 and 88E3083 contain all of the active circuitry to convert data streams to and from eight Media Access Controllers (MACs) and to and from the physical media. In addition, both devices incorporate IEEE 802.3u Auto-Negotiation in support of both 100BASE-TX and 10BASE-T networks over twisted-pair cable in full-duplex or half-duplex mode.

To reduce the number of input/output (I/O) pins between the MAC and the Physical Layer (PHY), the 88E3082 supports the Reduced Media Independent Interface (RMII), the Serial Media Independent Interface (SMII), and the source-synchronous option of SMII (SSSMII). The SSSMII interface extends the allowed PCB trace distance between the PHY and the MAC, thereby facilitating more robust, higher port density FE switch designs. The 88E3083 supports the SMII and SSSMII interfaces.

The 88E3082 also features a mode of operation supporting IEEE-compliant 100BASE-FX fiber-optic networks. The device includes a PECL interface that is selectable on a per-port basis for 100BASE-FX applications. The 88E3083 supports 100BASE-FX fiber on a single port.

BLOCK DIAGRAM

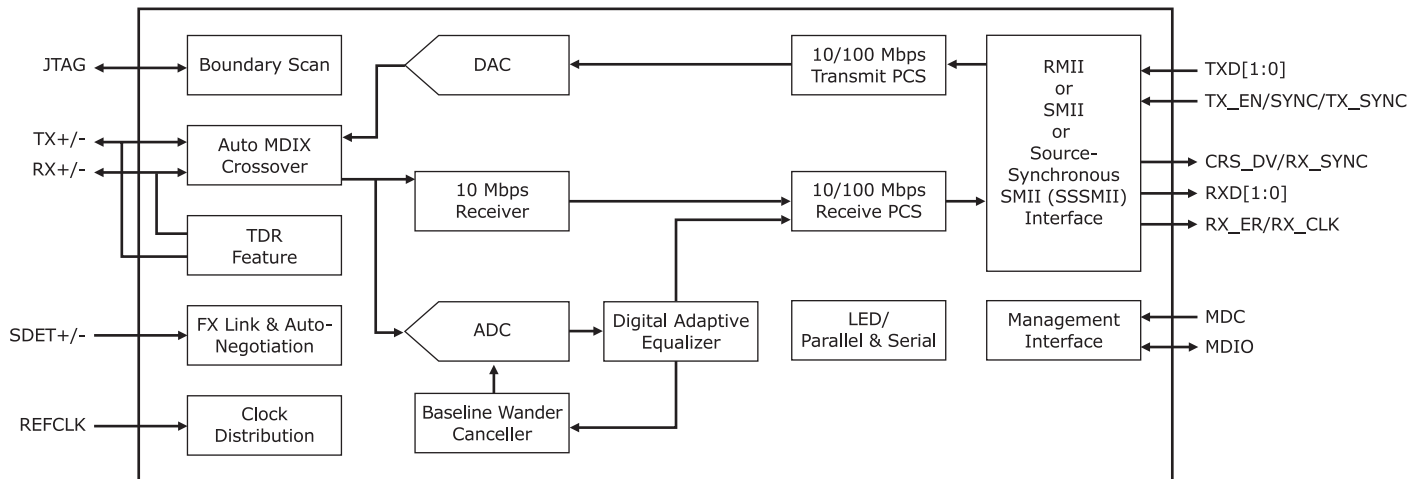

Fig 1. 88E3082 (Single-Port) Functional Block Diagram

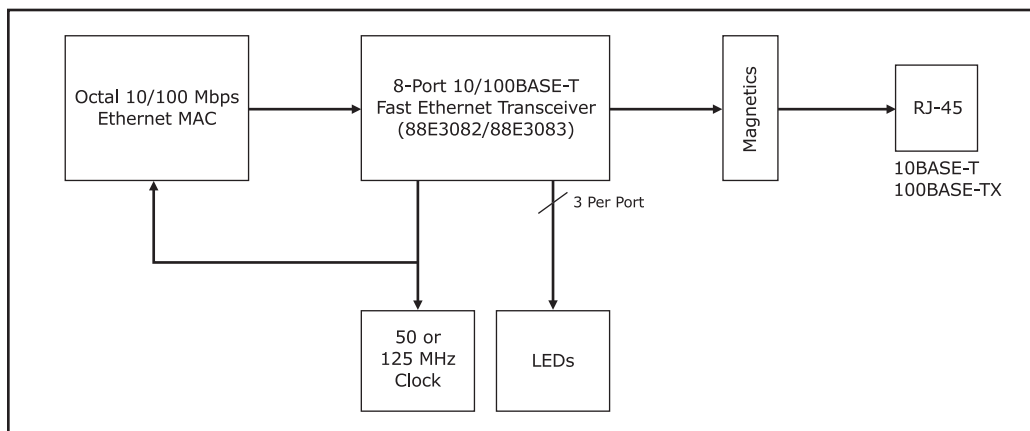

Fig 2. 88E3082/88E3083 System Diagram

▶ FEATURES	BENEFITS
<ul style="list-style-type: none"> Eight independent IEEE 802.3 compliant 100BASE-TX and 10BASE-T ports 	<ul style="list-style-type: none"> Enable higher port density switch system design
<ul style="list-style-type: none"> PECL interface supporting 100BASE-FX applications on a per port basis (88E3082 only; 88E3083 supports one fiber port) 	<ul style="list-style-type: none"> Supports FE over fiber applications
<ul style="list-style-type: none"> RMII, SMII, and SSSMII interfaces (RMII supported on 88E3082 only) 	<ul style="list-style-type: none"> Provides user configurable digital interfaces. SSSMII option extends the distance between the PHY and SW/MAC chip on the PCB design
<ul style="list-style-type: none"> Lower power dissipation, 150mW/port 	<ul style="list-style-type: none"> Yields higher port density and lower cost
<ul style="list-style-type: none"> Power management modes 	<ul style="list-style-type: none"> Reduces system power
<ul style="list-style-type: none"> Virtual Cable Tester feature 	<ul style="list-style-type: none"> Enables remote cable diagnostics for fault detection
<ul style="list-style-type: none"> Auto-MDI/MDIX crossover for 100BASE-TX and 10BASE-T ports 	<ul style="list-style-type: none"> Simplifies and reduces the cost of networking installation
<ul style="list-style-type: none"> Jumbo frame support to 10 KB with up to +/-150 ppm clock jitter 	<ul style="list-style-type: none"> Supports applications that demand larger packet sizes
<ul style="list-style-type: none"> IEEE 802.3u Auto-Negotiation support for automatic speed and duplex selection 	<ul style="list-style-type: none"> Enables a plug-and-play network system
<ul style="list-style-type: none"> Far-End-Fault-Indication (FEFI) support for 100BASE-FX applications 	<ul style="list-style-type: none"> Improves network reliability
<ul style="list-style-type: none"> 100BASE-TX performance over 150 meters 	<ul style="list-style-type: none"> Tolerates more cable mismatch and extends the receiving distance over 150 meters on standard CAT 5 cable
<ul style="list-style-type: none"> Flexible serial and parallel LED support 	<ul style="list-style-type: none"> Eliminates cost of external LED latches and drivers
<ul style="list-style-type: none"> IEEE 1149.1 standard test access port and boundary scan compatible 	<ul style="list-style-type: none"> Allows for implementation of JTAG function facilitating board-level debugging
<ul style="list-style-type: none"> Small outline packaging; 88E3082 in 224-pin TFBGA, 88E3083 in 128-pin LQFP 	<ul style="list-style-type: none"> Provides flexible package options for reduced PCB real estate

▶ APPLICATIONS

The Marvell Alaska 88E3082 and 88E3083 8-port transceivers are ideal for high-port density FE routers, hubs, and switches. The ultra-low power dissipation of only 150mw per port and the Marvell VCT advanced cable diagnostics enable the most cost-effective designs.

	88E3082	88E3083
Package	224-Pin TFBGA	128-Pin LQFP
RMII	Yes	No
SMII	Yes	Yes
SSSMII	Yes	Yes
DDR-SSSMII	Yes	Yes
Virtual Cable Tester	Yes	Yes
Fiber Support	All Ports	Port 7 Only
Parallel LEDs	Yes	Yes
Serial LED Mode	Yes	No
Power Management	Yes	Yes
Industrial Grade	Yes	No

Fig 3. Device Feature Comparison

THE MARVELL ADVANTAGE: Marvell products come with complete reference designs which include board layout designs, software, manufacturing diagnostic tools, documentation, and other items to assist customers with product evaluation and production. Marvell’s worldwide field application engineers collaborate closely with end customers to develop and deliver new leading-edge products for quick time-to-market. Marvell utilizes world-leading semiconductor foundry and packaging services to reliably deliver high-volume and low-cost total solutions.

ABOUT MARVELL: Marvell is the leader in storage, communications and consumer silicon solutions. Marvell’s diverse product portfolio includes switching, transceiver, communications controller, processors, wireless, power management and storage solutions that power the entire communications infrastructure, including enterprise, metro, home, storage, and digital entertainment solutions. For more information, visit our website at www.marvell.com.



Marvell Semiconductor, Inc.
5488 Marvell Lane
Santa Clara, CA 95054
Phone 408.222.2500
www.marvell.com

Copyright © 2007, Marvell International Ltd. All rights reserved. Marvell, the Marvell logo, Moving Forward Faster, Alaska, Datacom Systems on Silicon, Fastwriter, Libertas, Link Street, NetGX, PHYAdvantage, Prestera, Raising The Technology Bar, The Technology Within, Virtual Cable Tester, and Yukon are registered trademarks of Marvell. Marvell Makes It All Possible, Ants, AnyVoltage, Discovery, DSP Switcher, Feroceon, GalNet, GalTis, Horizon, RADLAN, UniMAC, and VCT are trademarks of Marvell. All other trademarks are the property of their respective owners.

X-ON Electronics

Largest Supplier of Electrical and Electronic Components

Click to view similar products for [Ethernet ICs category](#):

Click to view products by [Marvell manufacturer](#):

Other Similar products are found below :

[EZFM6324A S LKA5](#) [EZFM6364A S LKA7](#) [12200BS23MM](#) [EZFM5224A S LKA3](#) [VSC8522XJQ-02](#) [WGI219LM SLKJ3](#) [EZFM6348A S LKA6](#) [WGI219V SLKJ5](#) [BCM84793A1KFSBG](#) [BCM56680B1KFSBLG](#) [BCM53402A0KFSBG](#) [BCM56960B1KFSBG](#) [EZX557AT2 S LKVX](#) [BCM56842A1KFTBG](#) [BCM56450B1KFSBG](#) [EZX557AT S LKW4](#) [LAN9254-I/JRX](#) [RTL8211FS-CG](#) [RTL8153-VC-CG](#) [CH395L](#) [KTI225IT S LNNK](#) [KTI225IT S LNNL](#) [VSC8562XKS-14](#) [BCM56864A1IFSBG](#) [KSZ8462FHLLI](#) [LAN9303MI-AKZE](#) [KSZ8841-16MVLI](#) [X550T2BLK](#) [KSZ8842-16MVLI](#) [KSZ8893MQL](#) [VSC8244XHG](#) [ADIN2111BCPZ](#) [ADIN2111CCPZ-R7](#) [FIDO2100BGA128IR0](#) [FIDO5210CBCZ](#) [FIDO5210BBCZ](#) [FIDO5110CBCZ](#) [FIDO5200CBCZ](#) [ADIN1110BCPZ](#) [ADIN1110CCPZ](#) [ADIN1100BCPZ](#) [ADIN1110CCPZ-R7](#) [ADIN1100CCPZ-R7](#) [ADIN1110BCPZ-R7](#) [DM9000EP](#) [DM9161AEP](#) [HG82567LM S LAVY](#) [LAN9210-ABZJ](#) [LAN9221-ABZJ](#) [LAN9221I-ABZJ](#)