

### Features

- Low On-Resistance
- Fast switching
- High Input Resistance
- RoHS Compliant

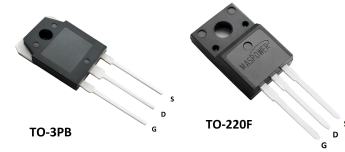

### Applications

- Electronic ballasts
- Electronic Transformer
- Switch Mode Power Supply

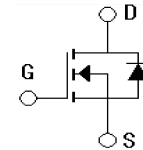

### Absolute Ratings (Tc=25°C)

Parameter	Symbol	Value	Unit
Drain-Source Voltage	V <sub>DSS</sub>	500	V
Drain Current -continuous	I <sub>D</sub> , T=25°C T=100°C	20*	A
		15	A
Drain Current - pulse (note 1)	I <sub>DM</sub>	80	A
Gate-Source Voltage	V <sub>GSS</sub>	±30	V
Single Pulsed Avalanche Energy (note 2)	E <sub>AS</sub>	1100	mJ
Power Dissipation (TO-3PB\TO-247\TO-220)	PD TC=25°C	290	W
		2.17	W/°C
Power Dissipation(TO-220F)	PD TC=25°C	31.7	W
		0.25	W/°C
Storage Temperature	T <sub>STG</sub>	-55~+150	°C
Junction Temperature	T <sub>j</sub>	150	°C

\*Drain current limited by maximum junction temperature

### Electrical Characteristics(T<sub>CASE</sub>=25°C unless otherwise specified)

Parameter	Symbol	Tests conditions	Min	Type	Max	Units
<b>Off-Characteristics</b>						
Drain-Source Voltage	BV <sub>DSS</sub>	I <sub>D</sub> =250uA, V <sub>GS</sub> =0V	500	-	-	V
Breakdown Voltage Temperature Coefficient	ΔBV <sub>DSS</sub> /ΔT <sub>J</sub>	I <sub>D</sub> =250μA, referenced to 25°C	-	0.6	-	V/°C

Drain cut-off current	I <sub>DSS</sub>	V <sub>DS</sub> =500V, V <sub>GS</sub> =0V T <sub>j</sub> =25°C	-	-	1	μA
		V <sub>DS</sub> =400V, T <sub>j</sub> =125°C	-	-	10	
Gate-body leakage current, forward	I <sub>GSSF</sub>	V <sub>DS</sub> =0V, V <sub>GS</sub> =30V	-	-	100	nA
Gate-body leakage current, reverse	I <sub>GSSR</sub>	V <sub>DS</sub> =0V, V <sub>GS</sub> =-30V	-	-	-100	nA
<b>On-Characteristics</b>						
Gate Threshold Voltage	V <sub>GS(th)</sub>	V <sub>DS</sub> =V <sub>GS</sub> , I <sub>D</sub> =250uA	2.0	-	5.0	V
Static Drain-Source On-Resistance	R <sub>DS(ON)</sub>	V <sub>GS</sub> =10V, I <sub>D</sub> =12A (note 3)	-	0.2	0.25	Ω
Forward Transconductance	g <sub>fs</sub>	V <sub>DS</sub> =40V , I <sub>D</sub> =12.0A (note 3)	-	90	-	S
<b>Dynamic Characteristics</b>						
Input capacitance	C <sub>iss</sub>	V <sub>DS</sub> =25V, V <sub>GS</sub> =0V, f=1.0MHZ	-	3200	-	pF
<b>Switching Characteristics</b>						
Turn-On delay time	t <sub>d(on)</sub>	V <sub>DD</sub> =250V, I <sub>D</sub> =20A, R <sub>G</sub> =25Ω, V <sub>GS</sub> =10V(note 4,5)	-	200	-	ns
Total Gate Charge	Q <sub>g</sub>	V <sub>DS</sub> =400V, I <sub>D</sub> =20A, V <sub>GS</sub> =10V(note4,5)	-	62.5	-	nC
Gate-Source charge	Q <sub>gs</sub>		-	16.5	-	nC
Gate-Drain charge	Q <sub>gd</sub>		-	21.5	-	nC
<b>Drain-Source Diode Characteristics and Maximum Ratings</b>						
Drain-Source Diode Forward Voltage	V <sub>SD</sub>	V <sub>GS</sub> =0V, I <sub>S</sub> =20A (note 3)	-	-	1.4	V
Maximum Continuous Drain-Source Diode Forward Current		I <sub>S</sub>	-	-	24.0	A
Reverse recovery time	t <sub>rr</sub>	V <sub>GS</sub> =0V, I <sub>F</sub> =20A dI <sub>F</sub> /dt=100A/us(note 3)	-	400	-	ns
Reverse recovery charge	Q <sub>rr</sub>		-	4.2	-	uC

### Thermal Characteristic

Parameter	Symbol	Value		Unit
		MS20N50FB \FC\FT	MS20N50FS	

Thermal Resistance, Junction-to-Case	$R_{\theta JC}$	0.43	3.94	$^{\circ}C/W$
Thermal Resistance, Junction-to-Ambient	$R_{\theta JA}$	40	80	$^{\circ}C/W$

## Order Message

Order codes	Package	Packaging
MS20N50FB	TO-3PB	Tube
MS20N50FC	TO-247	Tube
MS20N50FS	TO-220F	Tube
MS20N50FT	TO-220	Tube

Notes:

1. Repetitive rating: Pulse width limited by maximum junction temperature
2. Starting  $T_j=25^{\circ}C$ ,  $V_{DD}=50V$ ,  $L=3.4mH$ ,  $R=25\Omega$ ,  $I_{AS}=24.0A$
3. Pulse Test : Pulse width  $\leq 300\mu s$ , Duty cycle  $\leq 2\%$

## Electrical Characteristics

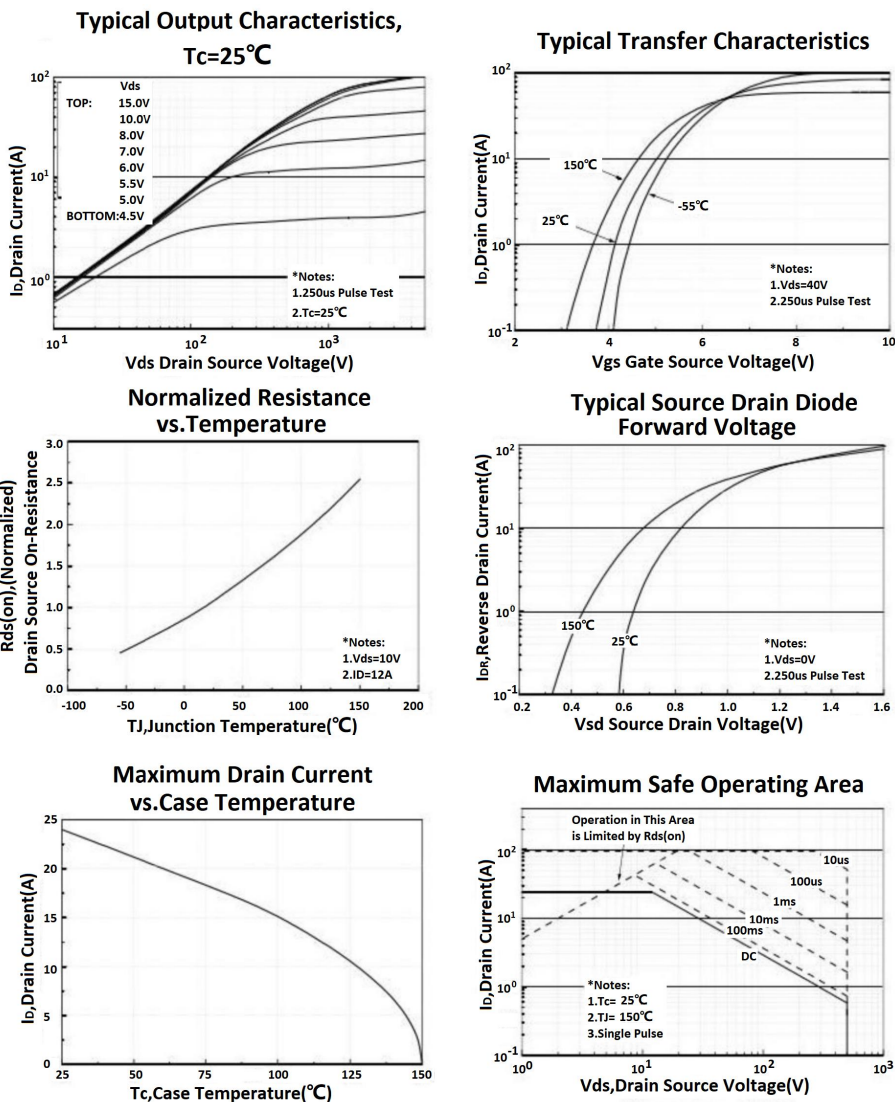

### On-Resistance Variation vs Drain Current

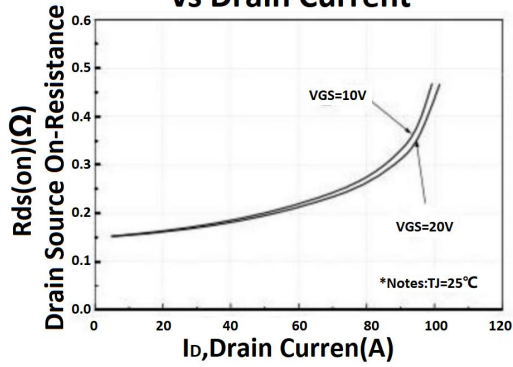

### Capacitance Characteristics

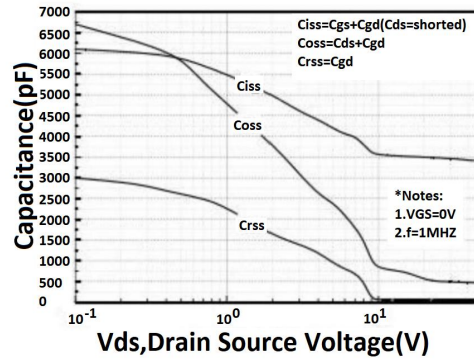

## Package Mechanical DATA

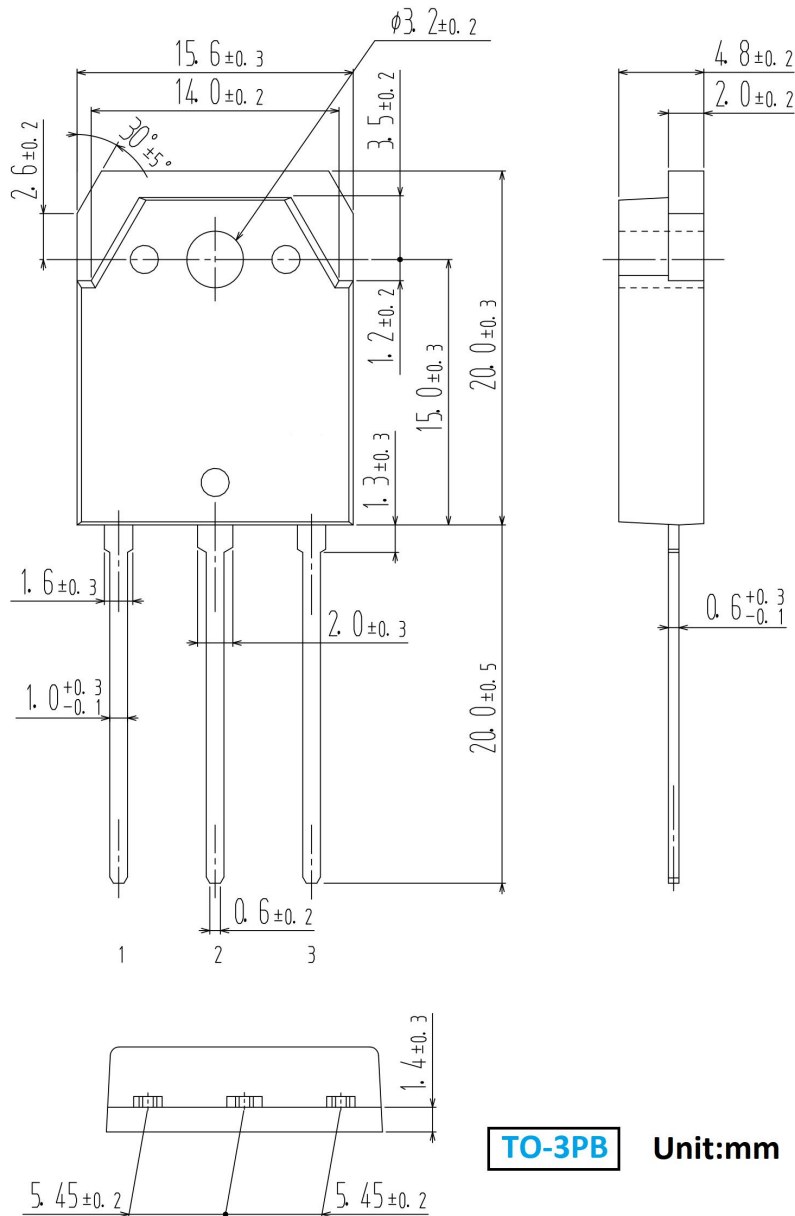

**TO-3PB** Unit:mm

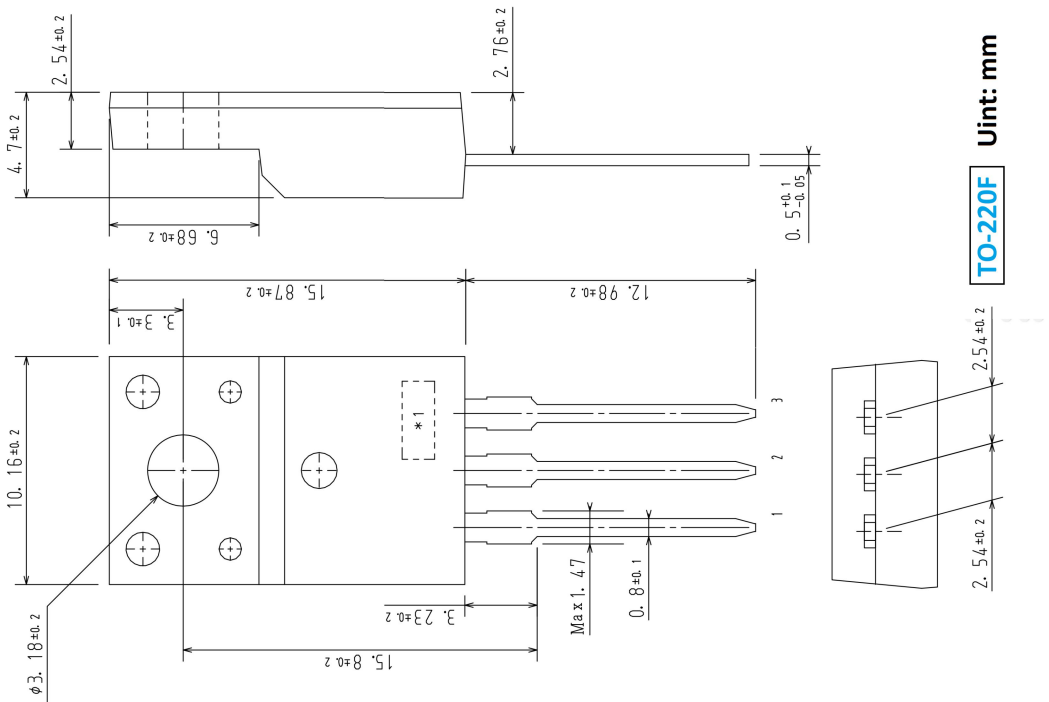
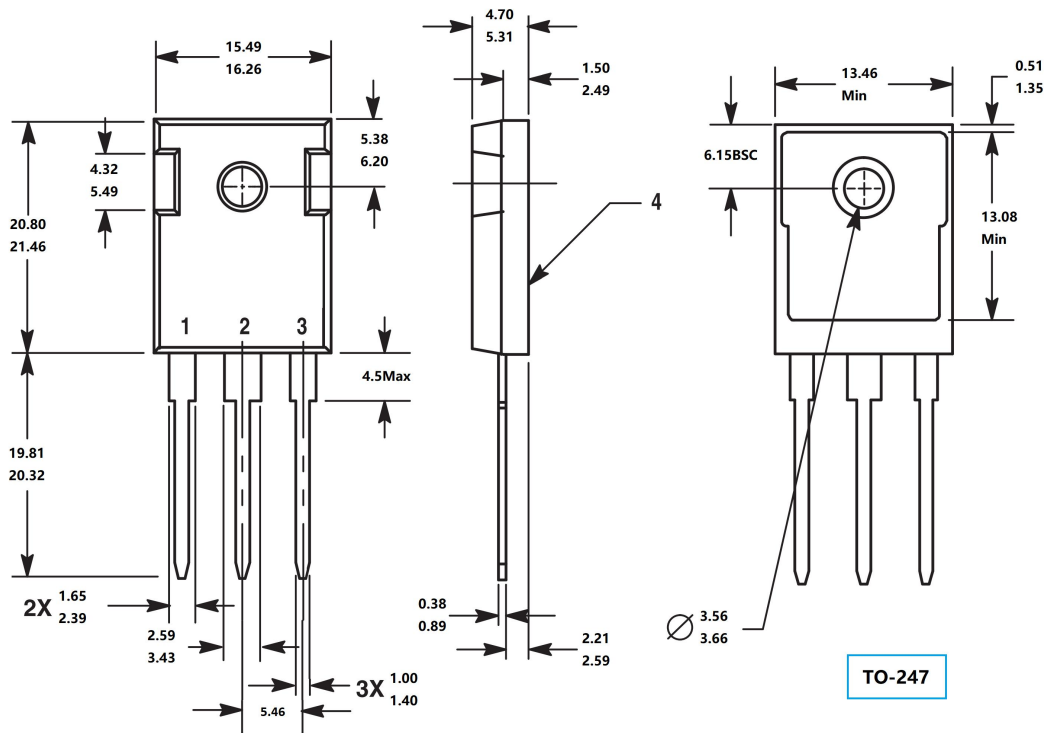

TO-220F Uint: mm



## X-ON Electronics

Largest Supplier of Electrical and Electronic Components

*Click to view similar products for [MOSFET](#) category:*

*Click to view products by [MASPOWER](#) manufacturer:*

Other Similar products are found below :

[IRFD120](#) [IRFY240C](#) [JANTX2N5237](#) [2SK2267\(Q\)](#) [BUK455-60A/B](#) [MIC4420CM-TR](#) [VN1206L](#) [NDP4060](#) [SI4482DY](#)  
[IPS70R2K0CEAKMA1](#) [SQD23N06-31L-GE3](#) [TK16J60W,S1VQ\(O](#) [2SK2614\(TE16L1,Q\)](#) [DMN1017UCP3-7](#) [EFC2J004NUZTDG](#)  
[DMN1053UCP4-7](#) [SQJ469EP-T1-GE3](#) [NTE2384](#) [DMC2700UDMQ-7](#) [DMN2080UCB4-7](#) [DMN61D9UWQ-13](#) [US6M2GTR](#)  
[DMN31D5UDJ-7](#) [DMP22D4UFO-7B](#) [DMN1006UCA6-7](#) [DMN16M9UCA6-7](#) [STF5N65M6](#) [IRF40H233XTMA1](#) [STU5N65M6](#)  
[DMN6022SSD-13](#) [DMN13M9UCA6-7](#) [DMTH10H4M6SPS-13](#) [DMN2990UFB-7B](#) [IPB80P04P405ATMA2](#) [2N7002W-G](#) [MCAC30N06Y-](#)  
[TP](#) [MCQ7328-TP](#) [NTMC083NP10M5L](#) [NVMFS2D3P04M8LT1G](#) [BXP7N65D](#) [BXP4N65F](#) [AOL1454G](#) [WMJ80N60C4](#) [BXP2N20L](#)  
[BXP2N65D](#) [BXT1150N10J](#) [BXT1700P06M](#) [TSM60NB380CP](#) [ROG](#) [RQ7L055BGTCR](#) [DMNH15H110SK3-13](#)