

GENERAL DESCRIPTION

The 78M6610+LMU is an energy measurement processor (EMP) for load monitoring and control of any 2-wire single-phase or 3-wire split-phase (120/180°) AC circuit. It provides flexible sensor configuration of four analog inputs and numerous host interface options for easy integration into any system architecture.

The internal 24-bit processor and field upgradeable firmware performs all the necessary signal processing, compensation, and data formatting for accurate real-time measurement. Energy accumulation, alarm monitoring, and fault detection schemes minimize the overhead requirements of the host interface and/or network. The integrated flash memory also provides for nonvolatile storage of input configurations and calibration coefficients.

APPLICATIONS

- Building Automation Systems (Commercial, Industrial)
- Inverters and Renewable Energy Systems
- Level 1 and 2 EV Charging Systems
- Grid-Friendly Appliances and Smart Plugs

FEATURES

- Four Configurable Analog Inputs for Monitoring Any Single-Phase Circuit (2/3-Wire)
- Supports Current Transformers (CT) and Resistive Shunts
- Flexible SPI, I²C, or UART Interface Options with Configurable I/O Pins for Alarm Signaling, Address Pins, or User Control
- Nonvolatile Storage of Calibration and Configuration Parameters
- Small 24-TQFN Package and Reduced Bill of Materials
- Internal or External Oscillator Timing References
- Quick Calibration Routines Minimize Manufacturing (System) Cost

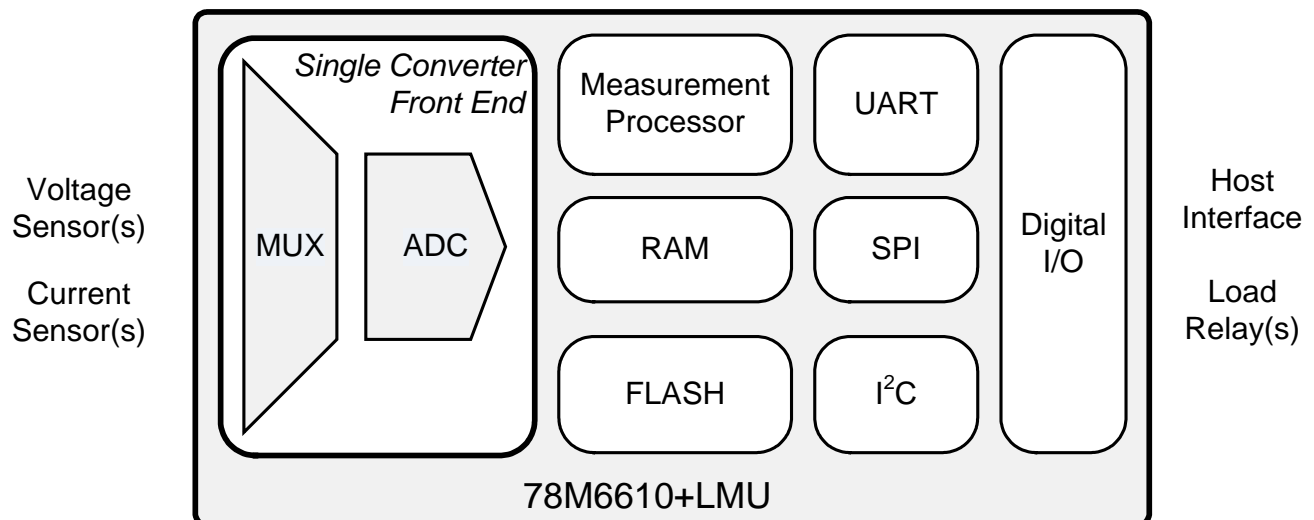

Table of Contents

Electrical Specifications	5
ABSOLUTE MAXIMUM RATINGS	5
Recommended External Components	5
Recommended Operating Conditions	5
Performance Specifications	6
Input Logic Levels	6
Output Logic Levels	6
Supply Current	6
Crystal Oscillator	6
Internal RC Oscillator	6
ADC Converter, V_{3P3} Referenced.....	7
Timing Specifications	8
Reset	8
SPI Slave Port	8
I ² C Slave Port (Note 1).....	9
Pin Configuration	10
Package Information	11
On-Chip Resources Overview	12
IC Block Diagram	12
Clock Management	13
Power-On and Reset Circuitry	14
Watchdog Timer.....	14
Analog Front-End and Conversion	15
24-Bit Energy Measurement Processor (EMP).....	15
Flash and RAM.....	15
Multipurpose DIOs	15
Communication Interface	15
Functional Description and Operation	16
Measurement Interface	16
AFE Input Multiplexer	16
High Pass Filters and Offset Removal	17
Gain Correction	18
Die Temperature Compensation	18
Phase Compensation	19
Voltage Input Configuration.....	20
Current Input Configuration.....	23
Data Refresh Rates	26
Scaling Registers	26
Calibration	27
Voltage and Current Gain Calibration	27
Offset Calibration	27
Die Temperature Calibration	27
Voltage Channel Measurements	28
Quadrature Voltage	28
Voltage Frequency	28
Peak Voltage	28
RMS Voltage	28
Current Channel Measurements.....	29
Peak Current	29
RMS Current	30
Crest Factor.....	30
Power Calculations	31

Active Power (P)	31
Reactive Power (Q)	32
Apparent Power (S)	32
Power Factor (PF)	32
Fundamental and Harmonic Calculations	33
Energy Calculations	34
Bucket Size for Energy Counters	34
Min/Max Tracking	36
Alarm Monitoring	37
Status Registers	39
Digital IO Functionality	40
DIO Polarity	40
Multipurpose (MP) Pins	41
Command Register	42
General Settings	42
No Action (0x00xxxx)	42
Save to Flash Command (0xACC2xx)	43
Clear Flash Storage 0 Command (0xACC0xx)	43
Clear Flash Storage 1 Command (0xACC1xx)	43
Calibration Command (0xCAxxxx)	44
Soft Reset (0xBDxxxx)	44
Control Register	44
Configuration Register	44
Register Access	46
Data Types	46
Register Locations	47
Serial Interfaces	51
UART Interface	51
RS-485 Support	51
Device Address Configuration	52
SSI Protocol Description	53
I ² C Interface	60
Device Address Configuration	60
Bus Characteristics	61
Device Addressing	61
Write Operations	62
Read Operations	63
78M6610+LMU/B48	64
UART Interface	64
Status Registers	64
Command Register	64
Config Register	64
Ordering Information	65
Contact Information	65
Revision History	66

Table of Figures

Figure 1. SPI Timing	8
Figure 2. I ² C Timing	9
Figure 3. QFN Package Pinout	10
Figure 4. Package Outline	11
Figure 5. Block Diagram.....	12
Figure 6. Crystal Connections.....	13
Figure 7. Reset Connections	14
Figure 8. AFE Input Multiplexer	16
Figure 9. Voltage Input Configuration	20
Figure 10. Voltage Computation	20
Figure 11. Example Voltage Configurations	21
Figure 12. Voltage Input Flowchart	22
Figure 13. Current Input Configuration	23
Figure 14. Current Computation	23
Figure 15. Current Configuration Examples.....	24
Figure 16. Current Input Flowchart	25
Figure 17. Peak Voltage Computation	28
Figure 18. RMS Voltage Computation	28
Figure 19. Peak Current Computation	29
Figure 20. RMS Current Computation	30
Figure 21. Active Power Computation	31
Figure 22. Reactive Power Computation	32
Figure 23. Apparent Power Computation.....	32
Figure 24. Min/Max Tracking	36
Figure 25. Voltage Sag	38
Figure 26. Relay Timing.....	41
Figure 27. RS-485 Interface.....	51
Figure 28. Device Address Configuration	52
Figure 29. SSI Protocol.....	53
Figure 30. Master Packet Structure	54
Figure 31: Signal Timing on the SPI Bus	57
Figure 32: Single Word Read Access Timing	58
Figure 33: Single Word Write Access Timing	59
Figure 34. I ² C Interface	60
Figure 35. I ² C Device Address.....	60
Figure 36. I ² C Bus Characteristics	61
Figure 37. I ² C Device Addressing	61
Figure 38. Write Operation Single Register	62
Figure 39. Write Operation Multiple Registers	62
Figure 40. Read Operation	63
Figure 41. Setting Read Address.....	63
Figure 42. Reading Multiple Registers.....	63

Electrical Specifications

ABSOLUTE MAXIMUM RATINGS

(All voltages with respect to ground.)

Supplies and Ground Pins:	
V_{3P3D} , V_{3P3A}	-0.5V to +4.6V
GNDD, GNDA	-0.5V to +0.5V
Analog Input Pins:	
A0, A1, A2, A3, A4, A5	-10mA to +10mA -0.5V to ($V_{3P3} + 0.5V$)
Oscillator Pins:	
XIN, XOUT	-10mA to +10mA -0.5V to +3.0V
Digital Pins:	
IFC0, IFC1, SSB/DIR/SCL, SDO/TX/SDAO, SDI/RX/SDAI, $\overline{\text{RESET}}$, SCK/ADDR0, MP10, MP0, MP4, MP6/ADDR1, MP7	-30mA to +30mA, -0.5V to ($V_{3P3D} + 0.5V$)
Digital Pins Configured as Inputs	-10mA to +10mA, -0.5V to +6V
Temperatures:	
Operating Junction Temperature)	
Peak, 100ms	+140°C
Continuous	+125°C
Storage Temperature Range	-65°C to +150°C
Lead Temperature (soldering, 10s)	+260°C
Soldering Temperature (reflow)	+300°C
ESD Stress on All Pins	±4kV

Stresses beyond those listed under "Absolute Maximum Ratings" may cause permanent damage to the device. These are stress ratings only, and functional operation of the device at these or any other conditions beyond those indicated in the operational sections of the specifications is not implied. Exposure to absolute maximum rating conditions for extended periods may affect device reliability.

Recommended External Components

NAME	FROM	TO	FUNCTION	VALUE	UNITS
XTAL	XIN	XOUT	20.000MHz	20.000	MHz
CXS	XIN	GNDD	Load capacitor for crystal (exact value depends on crystal specifications and parasitic capacitance of board)	18 ±10%	pF
CXL	XOUT	GNDD		18 ±10%	pF

Recommended Operating Conditions

PARAMETER	CONDITIONS	MIN	TYP	MAX	UNITS
3.3V Supply Voltage (V_{3P3})	Normal operation	3.0	3.3	3.6	V
Operating Temperature		-40		+85	°C

Performance Specifications

Note that production tests are performed at room temperature.

Input Logic Levels

PARAMETER	CONDITIONS	MIN	TYP	MAX	UNITS
Digital High-Level Input Voltage (V_{IH})		2			V
Digital Low-Level Input Voltage (V_{IL})				0.8	V

Output Logic Levels

PARAMETER	CONDITIONS	MIN	TYP	MAX	UNITS
Digital High-Level Output Voltage (V_{OH})	$I_{LOAD} = 1\text{mA}$	$V_{3P3} - 0.4$			V
	$I_{LOAD} = 10\text{mA}$	$V_{3P3} - 0.6$			V
Digital Low-Level Output Voltage (V_{OL})	$I_{LOAD} = 1\text{mA}$	0		0.4	V
	$I_{LOAD} = 10\text{mA}$			0.5	V

Supply Current

PARAMETER	CONDITIONS	MIN	TYP	MAX	UNITS
V_{3P3D} and V_{3P3A} Current (Compounded)	Normal operation, $V_{3P3} = 3.3\text{V}$		8.1	10.3	mA

Crystal Oscillator

PARAMETER	CONDITIONS	MIN	TYP	MAX	UNITS
XIN to XOUT Capacitance	(Note 1)		3		pF
Capacitance to GNDD (Note 1)	XIN		5		pF
	XOUT		5		

Note 1: Guaranteed by design; not subject to test.

Internal RC Oscillator

PARAMETER	CONDITIONS	MIN	TYP	MAX	UNITS
Nominal Frequency			20.000		MHz
Accuracy	$V_{3P3} = 3.0\text{V}, 3.6\text{V}$; temperature = -40°C to $+85^{\circ}\text{C}$		± 1.5	± 1.75	%

ADC Converter, V_{3P3} Referenced

LSB values do not include the 9-bit left shift at EMP input.

PARAMETER	CONDITIONS	MIN	TYP	MAX	UNITS
Usable Input Range ($V_{IN} - V_{3P3}$)		-250		+250	mV peak
THD (First 10 Harmonics)	$V_{IN} = 65\text{Hz}$, 64kpts FFT, Blackman-Harris window		-85		dB
Input Impedance	$V_{IN} = 65\text{Hz}$	30		90	k Ω
Temperature Coefficient of Input Impedance	$V_{IN} = 65\text{Hz}$ (Note 1)		1.7		$\Omega/^\circ\text{C}$
ADC Gain Error vs. %Power Supply Variation $\frac{10^6 \Delta N_{out_{PK}} 357nV / V_{IN}}{100 \Delta V_{3P3} A / 3.3}$	$V_{IN} = 200\text{mVpk}$, 65Hz; $V_{3P3} = 3.0\text{V}$, 3.6V			50	ppm/%
Input Offset ($V_{IN} - V_{3P3}$)		-10		+10	mV

¹ Guaranteed by design; not subject to test.

Timing Specifications

Reset

PARAMETER	CONDITIONS	MIN	TYP	MAX	UNITS
Reset Pulse Fall Time	(Note 1)		1		μs
Reset Pulse Width	(Note 1)		5		μs

SPI Slave Port

PARAMETER	CONDITIONS	MIN	TYP	MAX	UNITS
SCK Cycle Time (t_{SPICyc})		1			μs
Enable Lead Time (t_{SPILeAd})		15			ns
Enable Lag Time (t_{SPILag})		0			ns
SCK Pulse Width (t_{SPIW})	High	250			ns
	Low	250			
SSB to First SCK Fall (t_{SPISCK})	Ignore if SCK is low when SSB falls (Note 1)		2		ns
Disable Time (t_{SPIDIS})	(Note 1)		0		ns
SCK to Data Out (SDO) (t_{SPIEV})				25	ns
Data Input Setup Time (SDI) (t_{SPISU})		10			ns
Data Input Hold Time (SDI) (t_{SPIH})		5			ns

Note 1: Guaranteed by design, not subject to test.

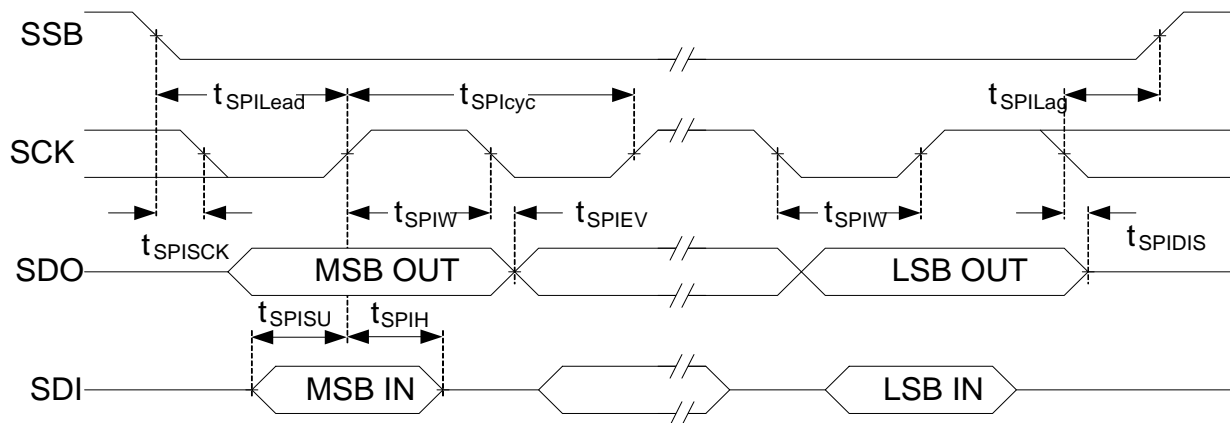

Figure 1. SPI Timing

I²C Slave Port (Note 1)

PARAMETER	CONDITIONS	MIN	TYP	MAX	UNITS
Bus Idle (Free) Time Between Transmissions (STOP/START) (t_{BUF})		1500			ns
I ² C Input Fall Time (t_{ICF})	(Note 2)	20		300	ns
I ² C Input Rise Time (t_{ICR})	(Note 2)	20		300	ns
I ² C START or Repeated START Condition Hold Time (t_{STH})		500			ns
I ² C START or Repeated START Condition Setup Time (t_{STS})		600			ns
I ² C Clock High Time (t_{SCH})		600			ns
I ² C Clock Low Time (t_{SCL})		1300			ns
I ² C Serial Data Setup Time (t_{SDS})		100			ns
I ² C Serial Data Hold Time (t_{SDH})		10			ns
I ² C Valid Data Time (t_{VDA}): SCL Low to SDA Output Valid ACK Signal from SCL Low to SDA (Out) Low				900	ns

Note 1: Guaranteed by design, not subject to test

Note 2: Dependent on bus capacitance.

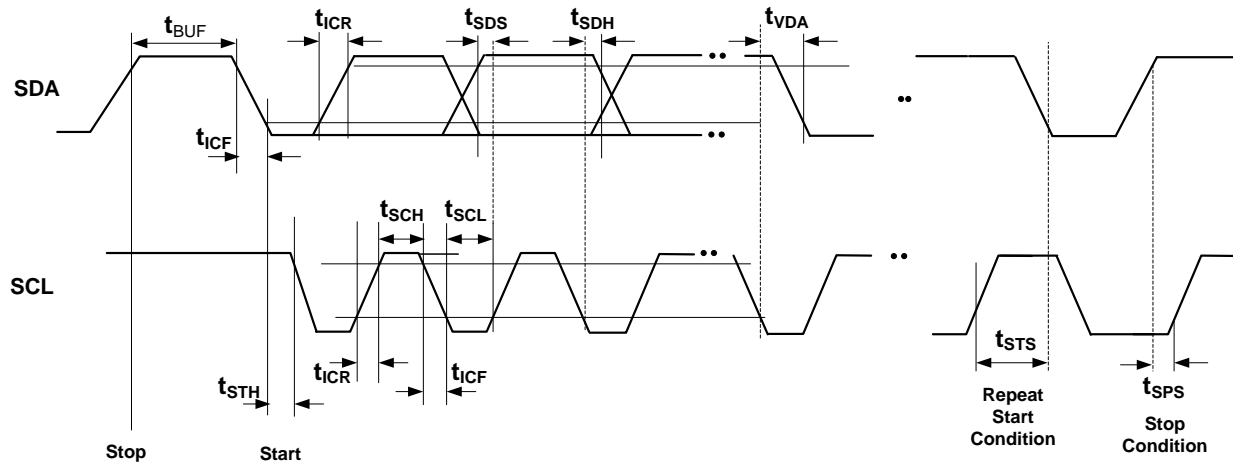

Figure 2. I²C Timing

Pin Configuration

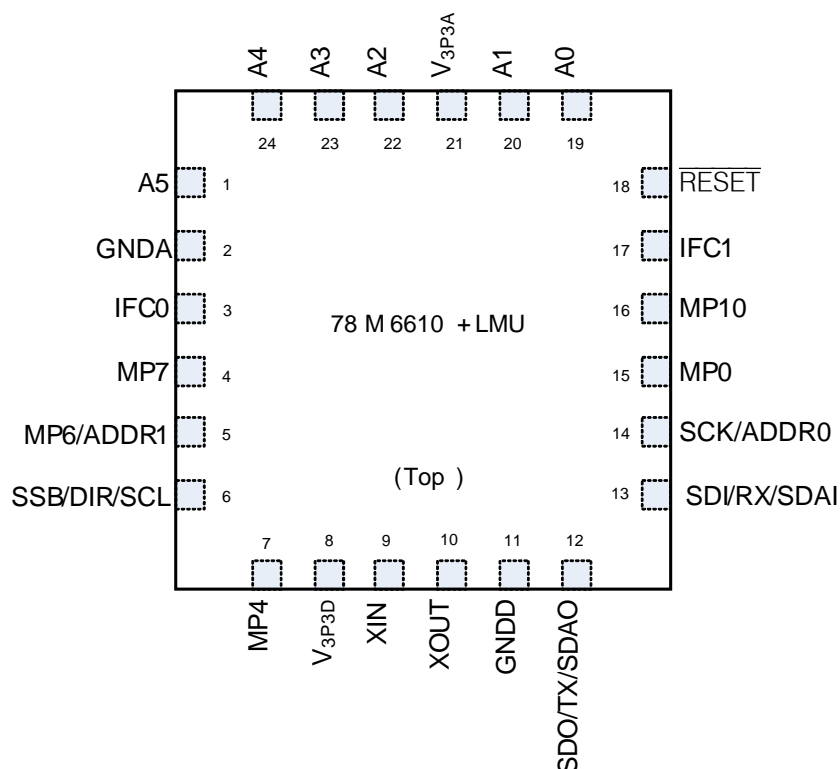

Figure 3. QFN Package Pinout

PIN	SIGNAL	FUNCTION	PIN	SIGNAL	FUNCTION
1	A5	Analog Input (Negative)	13	SDI/RX/ SDAI	SPI DATA IN/UART RX/ I ² C Data In
2	GNDA	Ground (Analog)	14	SCK/ ADDR0	SPI CLOCK/MPIO
3	IFC0	IFC1/SPI (1 = IFC1; 0 = SPI)	15	MP0	Multipurpose Digital I/O
4	MP7	Multipurpose Digital I/O	16	MP10	Multipurpose Digital I/O
5	MP6/ADDR1	Multipurpose Digital I/O	17	IFC1	I ² C/UART (1 = I ² C; 0 = UART)
6	SSB/DIR/ SCL	Slave Select (SPI)/RS-485 TX-RX/ I ² C Serial Clock	18		Active-Low Reset Input
7	MP4	Multipurpose Digital I/O	19	A0	Analog Input
8	V _{3P3D}	3.3V DC Supply (Digital)	20	A1	Analog Input
9	XIN	Crystal Oscillator Driver Input	21	V _{3P3A}	3.3V DC Supply (Analog)
10	XOUT	Crystal Oscillator Driver Output	22	A2	Analog Input (Positive)
11	GNDD	Ground (Digital)	23	A3	Analog Input (Negative)
12	SDO/TX/ SDAO	SPI DATA OUT/UART TX/ I ² C Data Out	24	A4	Analog Input (Positive)

Package Information

For the latest package outline information and land patterns (footprints), go to www.maximintegrated.com/packages. Note that a "+", "#", or "-" in the package code indicates RoHS status only. Package drawings may show a different suffix character, but the drawing pertains to the package regardless of RoHS status.

PACKAGE TYPE	PACKAGE CODE	OUTLINE NO.	LAND PATTERN NO.
24 TQFN	T2444+4	21-0139	90-0022

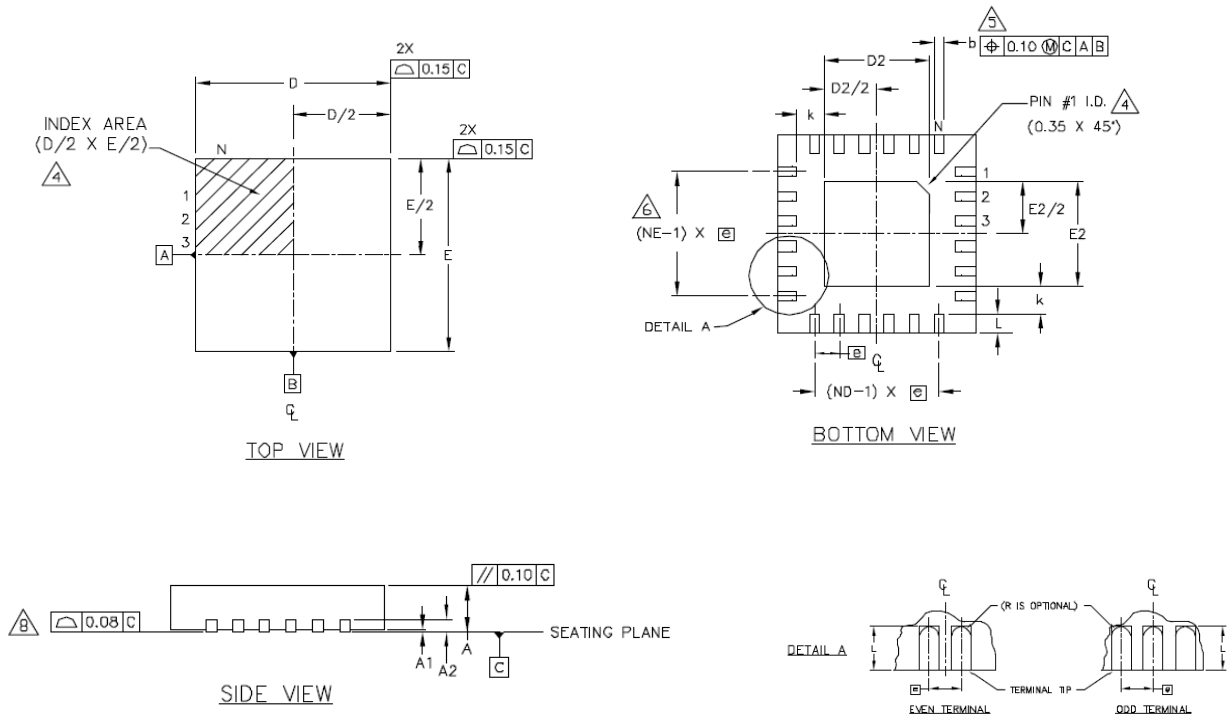

PKG	24L 4x4		
REF.	MIN.	NOM.	MAX.
A	0.70	0.75	0.80
A1	0.0	0.02	0.05
A2	0.20 REF		
b	0.18	0.23	0.30
D	3.90	4.00	4.10
E	3.90	4.00	4.10
e	0.50 BSC.		
k	0.25	-	-
L	0.30	0.40	0.50
N	24		
ND	6		
NE	6		
Jedec Var.	WGGD-2		

Figure 4. Package Outline

On-Chip Resources Overview

The 78M6610+LMU device integrates all the hardware blocks required for accurate AC power and energy measurement. Included on device are:

- Oscillator circuits and clock management logic
- Power-on reset, watchdog timer, and reset circuitry
- High-accuracy analog front-end (AFE) with trimmed voltage reference and temperature sensor
- 24-bit energy measurement processor (EMP) with RAM and flash memory
- Serial UART, SPI, I²C interfaces and multipurpose digital I/O

IC Block Diagram

The following is a block diagram of the hardware resources available on the 78M6610+LMU.

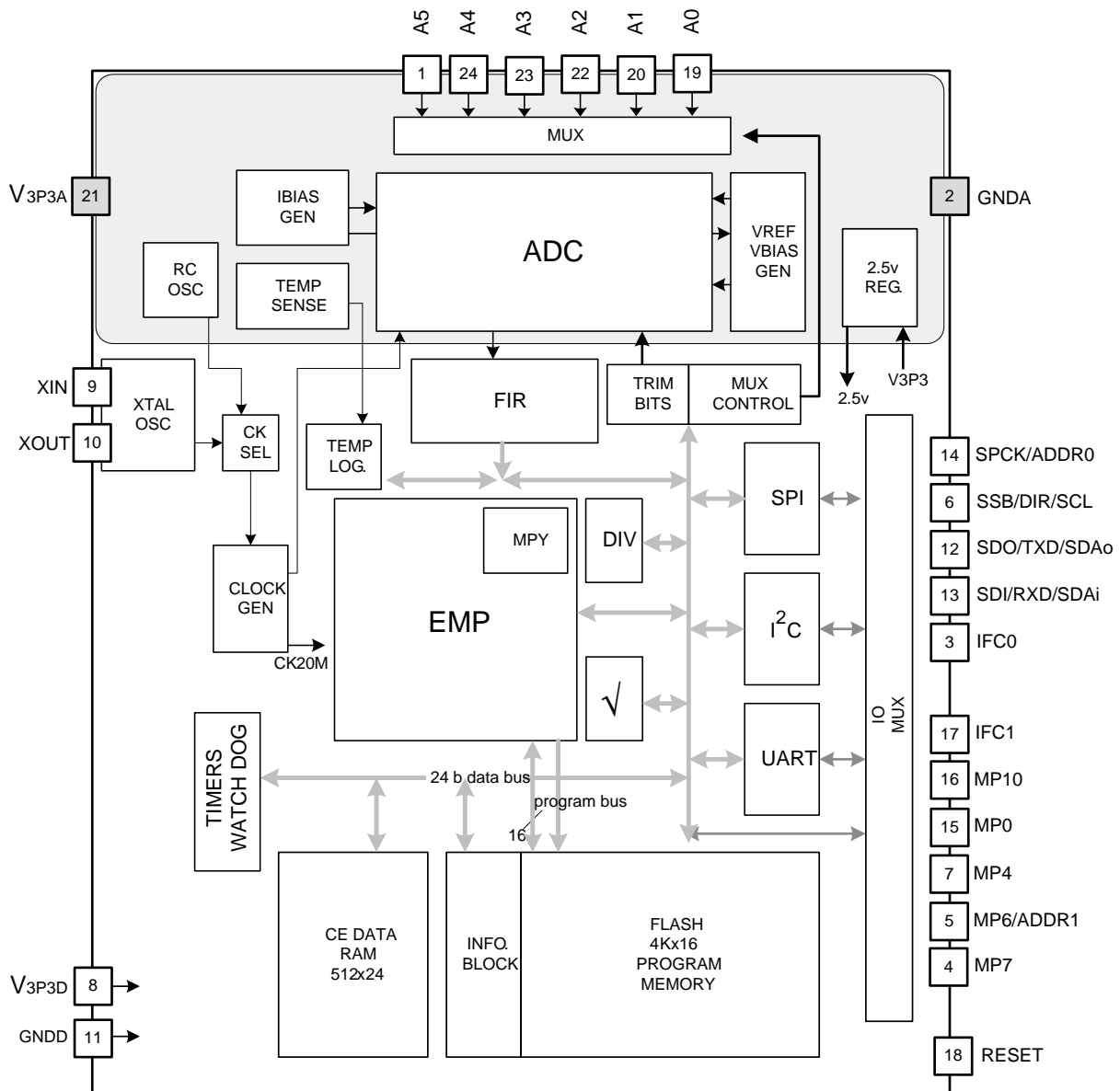

Figure 5. Block Diagram

Clock Management

The device can be clocked by either a trimmed internal RC oscillator or by oscillator circuitry that relies on an external crystal. The internal RC oscillator provides an accurate clock source for UART baud rate generation. Only time based calculations such as line frequency and watt-hour (energy) are affected by clock accuracy.

The chip hardware automatically handles the clock sources logic and distributes the clock to the rest of the device. Upon reset or power-on, the device will utilize the internal RC oscillator circuit for the first 1024 clock cycles, allowing the external crystal adequate time to start-up. The device will then automatically select the external clock, if available. It will also automatically switch back to the internal oscillator in the event of a failure with the external oscillator. This condition is also monitored by the processor and available to the user in the STATUS register.

The 78M6610+LMU external clock circuitry requires a 20.000MHz crystal. The circuitry includes two 18pF ceramic capacitors. The figure below shows the typical connection of the external crystal. This oscillator is self biasing and therefore an external resistor should NOT be connected across the crystal.

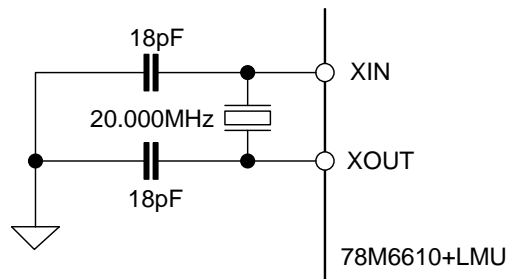

Figure 6. Crystal Connections

An external 20MHz system clock signal can also be utilized instead of the crystal. In this case, the external clock should be connected to the XOUT pin while the XIN pin should be connected to GNDD.

Alternatively, if no external crystal or clock is utilized, the XOUT pin should be connected to GNDD and the XIN pin left unconnected.

Power-On and Reset Circuitry

An on-chip power-on reset (POR) block monitors the supply voltage (V_{3P3D}) and initializes the internal digital circuitry at power-on. Once V_{3P3D} is above the minimum operating threshold, the POR circuit triggers and initiates a reset sequence. It will also issue a reset to the digital circuitry if the supply voltage falls below the minimum operating level.

In addition to the internal sources, a reset can be forced by applying a low level to the $\overline{\text{RESET}}$ pin. If the $\overline{\text{RESET}}$ pin is pulled low, all digital activities in the device stop, except the clock management circuitry and oscillators, which continue to run. The external reset input is filtered to prevent spurious reset events in noisy environments. The reset does not occur until $\overline{\text{RESET}}$ has been held low for at least 1 μs .

Once initiated, the reset mode persists until the $\overline{\text{RESET}}$ is set high and the reset timer times out (4096 clock cycles). At the completion of the reset sequence, the internal reset is released and the processor (EMP) begins executing from address 0.

If not used, the $\overline{\text{RESET}}$ pin can be connected either directly or through a pullup resistor to V_{3P3D} supply. A simple connection diagram is shown below.

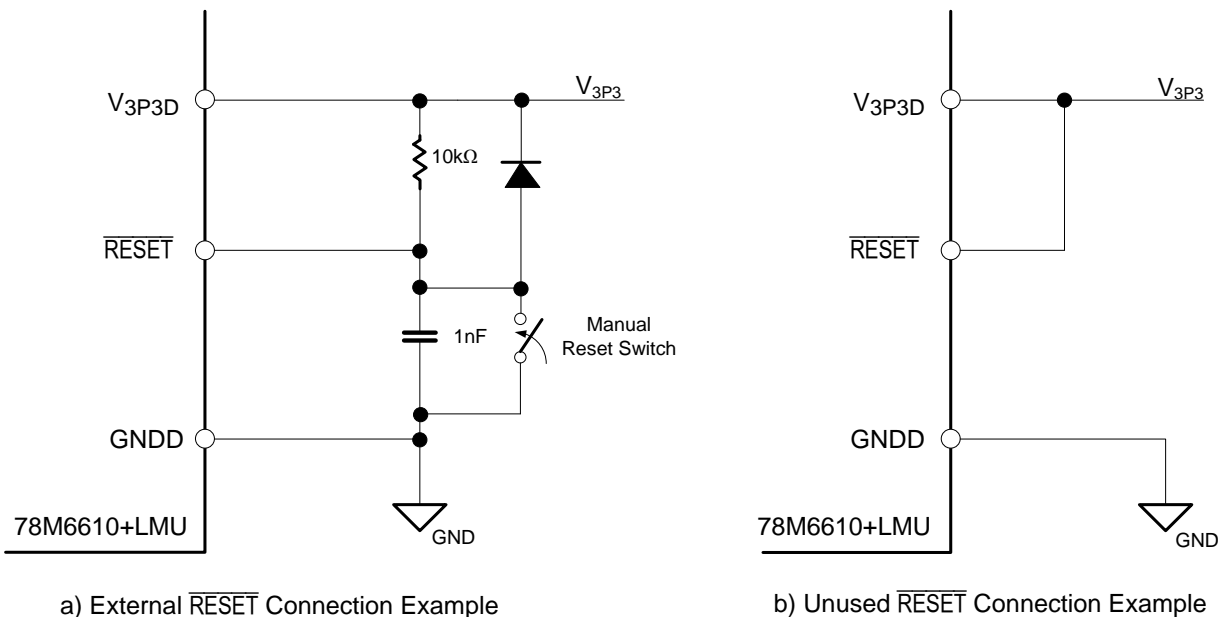

Figure 7. Reset Connections

Watchdog Timer

A Watchdog Timer (WDT) block detects any software processing errors. The software periodically refreshes the free-running watchdog timer to prevent it from timing out. If the WDT times out, it is an indication that software is no longer being executed in the intended sequence; thus, a system reset is initiated.

Analog Front-End and Conversion

The Analog Front-End (AFE) includes an input multiplexer, optional pre-amplifier gain stage, Delta-Sigma A/D Converter, bias current references, voltage references, temperature sensor, and several voltage fault comparators.

Analog Inputs

Up to four external sensors can be connected to the 78M6610+LMU. Two single-ended inputs are available for voltage sensors and two differential pairs are available for connecting current sensors. Although the current inputs are differential inputs, a common-mode voltage of less than $V_{3P3A} \pm 25$ mV is recommended in order to utilize the available dynamic range. The full-scale signal level that can be applied to the analog input pins is $V_{3P3A} \pm 250$ mVpk. Considering a sinusoidal AC waveform, the maximum RMS voltage applied to the inputs pins is:

$$\text{rmsMAX} = \frac{250\text{mVpk}}{\sqrt{2}} = 176.78\text{mVrms}$$

Delta-Sigma A/D Converter

A second-order Delta-Sigma converter digitizes the analog inputs. The converted data is then processed through a FIR filter.

Voltage Reference

The device includes an on-chip precision bandgap voltage reference that incorporates auto-zero techniques as well as production trims to minimize errors caused by component mismatch and drift. The voltage reference is digitally compensated over temperature.

Die Temperature Measurement

The device includes an on-chip die temperature sensor used for digital compensation of the voltage reference. It is also used to report temperature information to the user.

24-Bit Energy Measurement Processor (EMP)

The 78M6610+LMU integrates a dedicated 24-bit signal processor that performs the entire digital signal processing necessary for energy measurement, alarm generation, calibration, compensation, etc. Refer to [Section 2](#) for a description of functionality and operations.

Flash and RAM

The 78M6610+LMU includes 8KB of on-chip flash memory. The flash memory primarily contains program code, but also stores calibration data and defaults for select nonvolatile configuration registers. The device also includes 1.5KB of on-chip RAM which contains the values of input and output registers and is utilized by the processor for its operations.

Multipurpose DIOs

There are a total of eleven digital input/outputs (DIOs) on the 78M6610+LMU device. Some are dedicated to serial interface communications and configuration. Others are multipurpose I/O that can be used as a simple output under user control or routed to special purpose internal signals like alarm signaling and relay control.

Communication Interface

The 78M6610+LMU includes three communication interfaces: UART, SPI, and I²C. Since the I/O pins are shared, only one mode is supported at a time. Interface configuration and address pins are sampled at power-on or reset to determine which interface will be active and to set device addresses.

Functional Description and Operation

This section describes the operation and configuration of the 78M6610+LMU. It includes the flow of measurement data, relevant calculations, alarm monitoring, I/O control, and user configurations.

Measurement Interface

The 78M6610+LMU incorporates a flexible measurement interface for simplified integration into any single-phase system. This section describes the configuration and signal conditioning of the analog inputs.

Settings and calibration parameters described in this section can be saved to flash memory and automatically initialized upon power on or reset.

AFE Input Multiplexer

The 78M6610+LMU samples four (4) external sensors with an effective sample rate of 4Ksps for each multiplexer slot. Two analog input pins are defined as single ended voltage inputs with the other four analog input pins defined as a pair of differential current inputs.

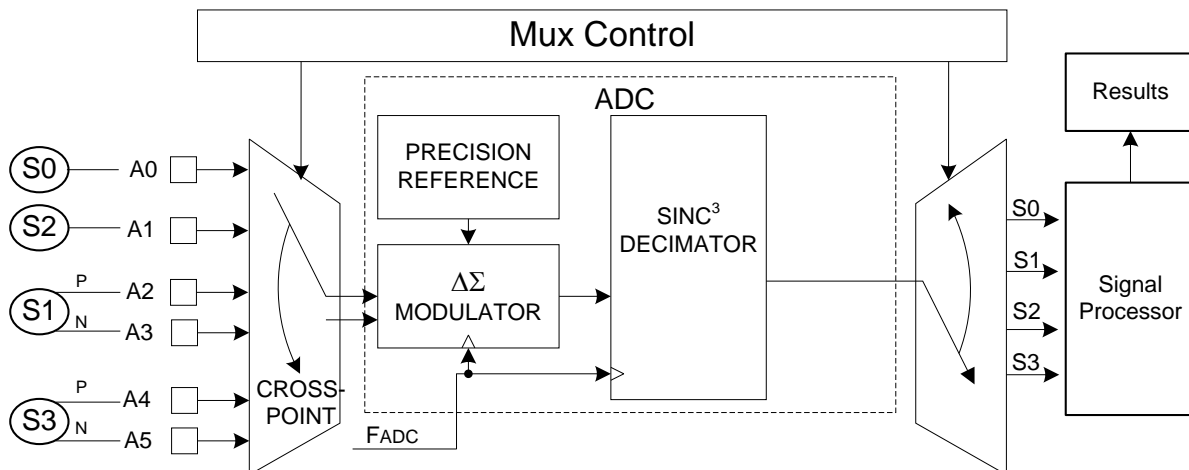

Figure 8. AFE Input Multiplexer

Sensor Slot	Analog Input Pins	Input Type
S0	A0	Voltage
S1	A2 (pos) and A3 (neg)	Current
S2	A1	Voltage
S3	A4 (pos) and A5 (neg)	Current

High Pass Filters and Offset Removal

Offset registers for each analog input contain values to be subtracted from the raw ADC outputs for the purpose of removing inherent system DC offsets from any calculated power and RMS values. These registers are signed fixed point numbers with a possible range of -1.0 to 1 - LSB. They default to 0 and can be manually changed by the user or integrated offset calibration routines.

Register	Description
S1_OFFS	Current Input S1 Offset Calibration
S0_OFFS	Voltage Input S0 Offset Calibration
S3_OFFS	Current Input S3 Offset Calibration
S2_OFFS	Voltage Input S2 Offset Calibration

Alternatively, the user can enable an integrated High Pass Filter (HPF) to dynamically update the offset registers every accumulation interval. During each accumulation interval (or low-rate cycle) the HPF calculates the median or DC average of each input. Adjustable coefficients determine what portion of the measured offset is combined with the previous offset value.

HPF_COEF_x registers contain signed fixed point numbers with a usable range of 0 to 1 - LSB (0.99999), negative values are not supported. By default, they are initialized to 0.5 (0x400000) meaning the new offset value will come from one-half of the measured offset and one-half will come from the previous offset value. Setting them to 1.0 (0x7FFFFFFF) causes the entire measured offset to be applied to the offset register enabling lump-sum offset removal. Setting them to zero disables any dynamic update of the offset registers by the HPF.

Register	Description
HPF_COEF_I	HPF coefficient for S1 and S3 current inputs
HPF_COEF_V	HPF coefficient for S0 and S2 voltage inputs

To allow the DC component of the load current to be included in the measurement (i.e. half-wave rectified current waveforms), the HPF_COEF_I coefficients must be set to zero.

Using the offset calibration routine will automatically set the filter coefficients to zero to disable the HPF.

Gain Correction

The system (sensors) and the 78M6610+LMU device inherently have gain errors that can be corrected by using the gain registers. These registers can be directly accessed and modified by an external processor or automatically updated by an integrated self calibration routine.

Input gain registers are signed fixed point numbers with the binary point to the left of bit 21. They are set to 1.0 by default and have a usable range of 0 to 4 - LSB, negative values are not supported. The gain equation for each input slot can be described as $S_x = S_x * S_x_GAIN$.

Register	Description
S0_GAIN	Voltage Input S0 Gain Calibration.
S1_GAIN	Current Input S1 Gain Calibration
S2_GAIN	Voltage Input S2 Gain Calibration.
S3_GAIN	Current Input S3 Gain Calibration

Die Temperature Compensation

The 78M6610+LMU has an on-chip temperature sensor that can be used by the signal processor for monitoring the voltage reference error and made available to the user in the TEMPC register.

Setting the Temperature Compensation (TC) bit in the Command Register allows the firmware to further adjust the system gain based on measured die temperature. Die Temperature Offset is typically calibrated by the user during the calibration stage. Die temperature gain is set to a factory default value for most applications, but can be adjusted by the user.

Register	Description
T_OFFS	Die Temperature Offset Calibration.
T_GAIN	Die Temperature Slope Calibration. Set by factory.

Voltage Reference Gain Adjustment

The on-chip precision bandgap voltage reference incorporates auto-zero techniques as well as production trims to minimize errors caused by component mismatch and drift. It can be assumed that the part is trimmed at 22°C to produce a uniform voltage reference gain at that temperature. The voltage reference is digitally compensated over changes in measured die temperature using a quadratic equation.

Phase Compensation

Phase compensation registers are used to compensate for phase errors or time delays between the voltage input source and respective current source that are introduced by the off-chip sensor circuit. The user configurable registers are signed fixed point numbers with the binary point to the left of bit 21. Values are in units of high rate (4kHz) sample delays so each integer unit of delay is 250µs with a total possible delay of ±4 samples (roughly ±20° at 60Hz).

Register	Description
PHASECOMP1	Phase (delay) compensation for S1 input current
PHASECOMP3	Phase (delay) compensation for S3 input current

Example:

To compensate a phase error of 277.77µs (or 6° at 60Hz) introduced by a current transformer (CT) it is necessary to enter the following:

$$\text{Phase Compensation} = \frac{\text{Phase Error}}{\frac{1}{\text{Sample Rate}}}$$

$$\text{Phase Compensation} = \frac{277E^{-6}}{\frac{1}{4000}} = 1.111$$

The value to be entered in the phase compensation register is therefore:

$$PComp = 1.111 * 2^{21} = 2330169 = 0x238E39$$

Voltage Input Configuration

The 78M6610+LMU supports multiple analog input configurations for determining the three potential voltage sources in a split-phase circuit. The device measures the voltage difference between any two references and uses this information to derive the voltages VA, VB, and VC as shown below.

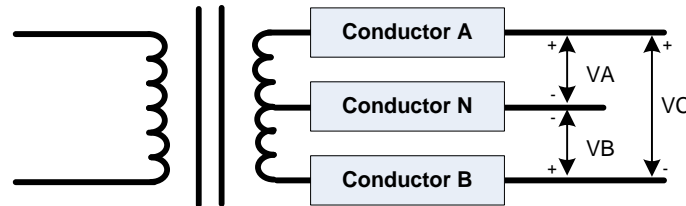

Figure 9. Voltage Input Configuration

Each calculated voltage source (VA, VB, and VC) is derived from the following user configurable function of the voltage input multiplexer slots (S0, S2) and three pairs of multiplier values (M0, M2). This function derives source voltages VA, VB, and VC by summing S0 x M0 and S2 x M2.

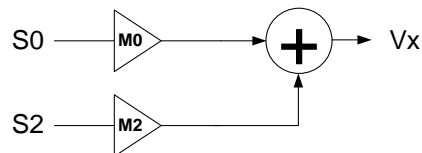

Figure 10. Voltage Computation

The user sets the multiplier values M0 and M2 for each voltage source in the CONFIG register using the model where a one (1) value adds the input, a two (2) value adds two of the input, a minus one (-1) value subtract the input, a zero (0) value does not include the input.

CONFIG Bits	19:18	17:16	15:14	13:12	11:10	9:8
Multiplier	M2	M0	M2	M0	M2	M0
Source	VC		VB		VA	

There are four choices for every M value as shown below.

Multiplier Bits	00	01	10	11
M (multiplier) Value	-1	0	1	2

The output registers VA, VB, and VC are automatically scaled by a factor of 0.5 if M0 and M2 are both nonzero.

For example, by setting the multiplier bits as follows:

$$V_c = +1 * S_0 - 1 * S_2$$

The effective content of the Vc register would result in:

$$V_c = \frac{(+1 * S_0) + (-1 * S_2)}{2}$$

This scaling is done to prevent the output register from overflowing.

Two example configurations are shown below. For determining the sign of S0 or S2 measurements, one should note that results for single ended inputs are referenced to V_{3P3} .

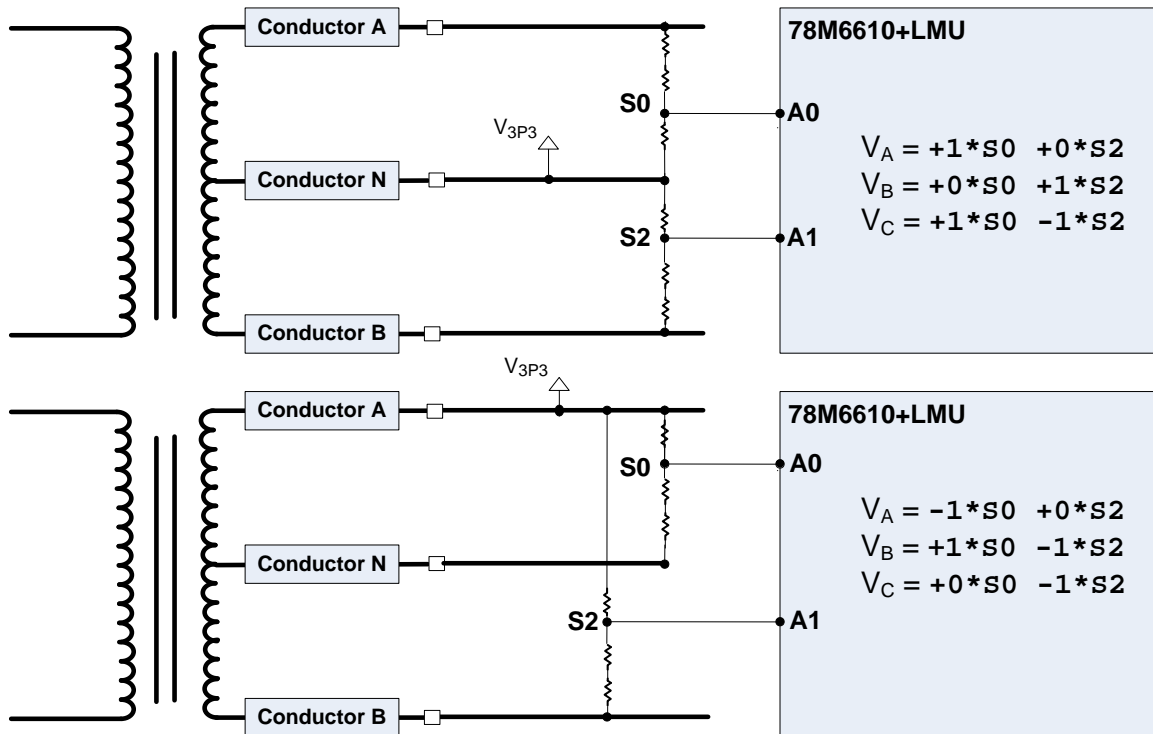

Figure 11. Example Voltage Configurations

Voltage Input Flowchart

The figure below illustrates the computational flowchart for VA, VB, and VC. The values for voltage input configuration register can be saved in flash memory and automatically restored at power-on or reset.

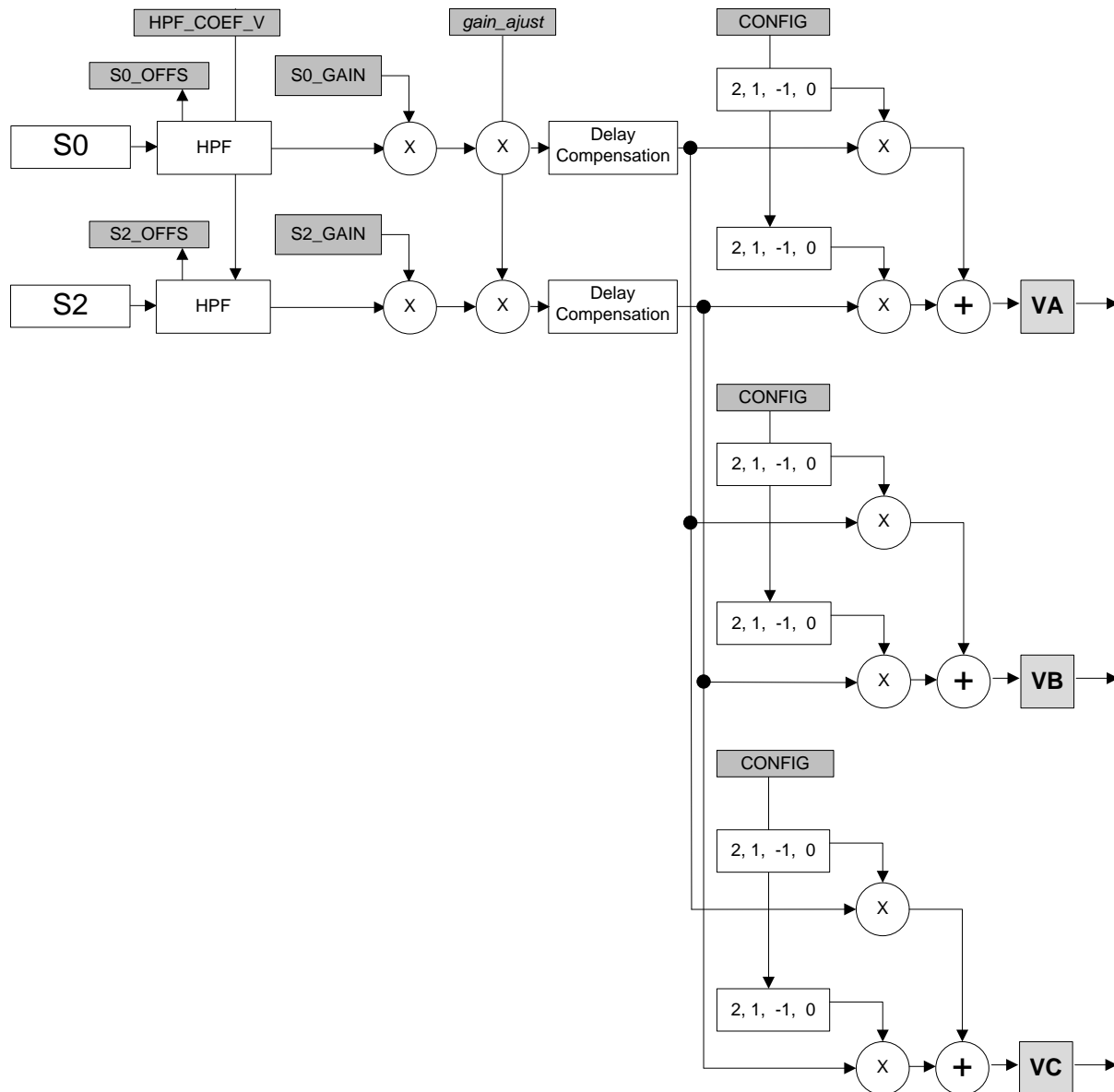

Figure 12. Voltage Input Flowchart

Current Input Configuration

The 78M6610+LMU supports multiple analog input configurations for determining the two load currents in a split-phase AC circuit. The device measures the current of any two conductors and uses this information to derive the load currents shown below.

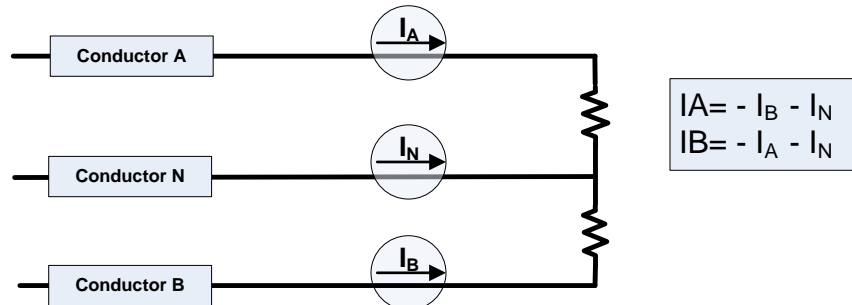

Figure 13. Current Input Configuration

Each calculated load current (I_A and I_B) is derived from the following function of the current input slots ($S1$ and $S3$) and 2 pairs of multiplier values ($M1$ and $M3$). This function derives source currents I_A and I_B by summing $S1 \times M1$ and $S3 \times M3$.

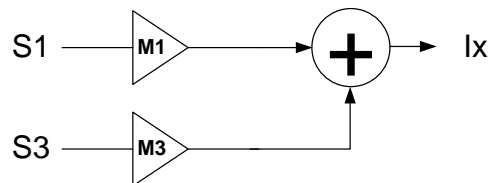

Figure 14. Current Computation

The user sets the multiplier values for each current source in the CONFIG register using the model where a one (1) value adds the input, a two (2) value adds two of the input, a minus one (-1) value subtract the input, a zero (0) value does not include the input.

CONFIG Bits	7:6	5:4	3:2	1:0
Multiplier	M3	M1	M3	M1
Source	IB		IA	

There are four choices for every M value as shown below.

Bit Values	00	01	10	11
M (multiplier) Value	-1	0	1	2

The output registers I_A and I_B are automatically scaled by a factor of 0.5 if $M1$ and $M3$ are both nonzero. For example, by setting the multiplier bits as follows:

$$IB = +1 * S1 - 1 * S3$$

The effective content of the V_c register would result in:

$$V_c = \frac{(+1 * S1) + (-1 * S3)}{2}$$

This scaling is done to prevent the output register from overflowing.

Current Configuration Examples

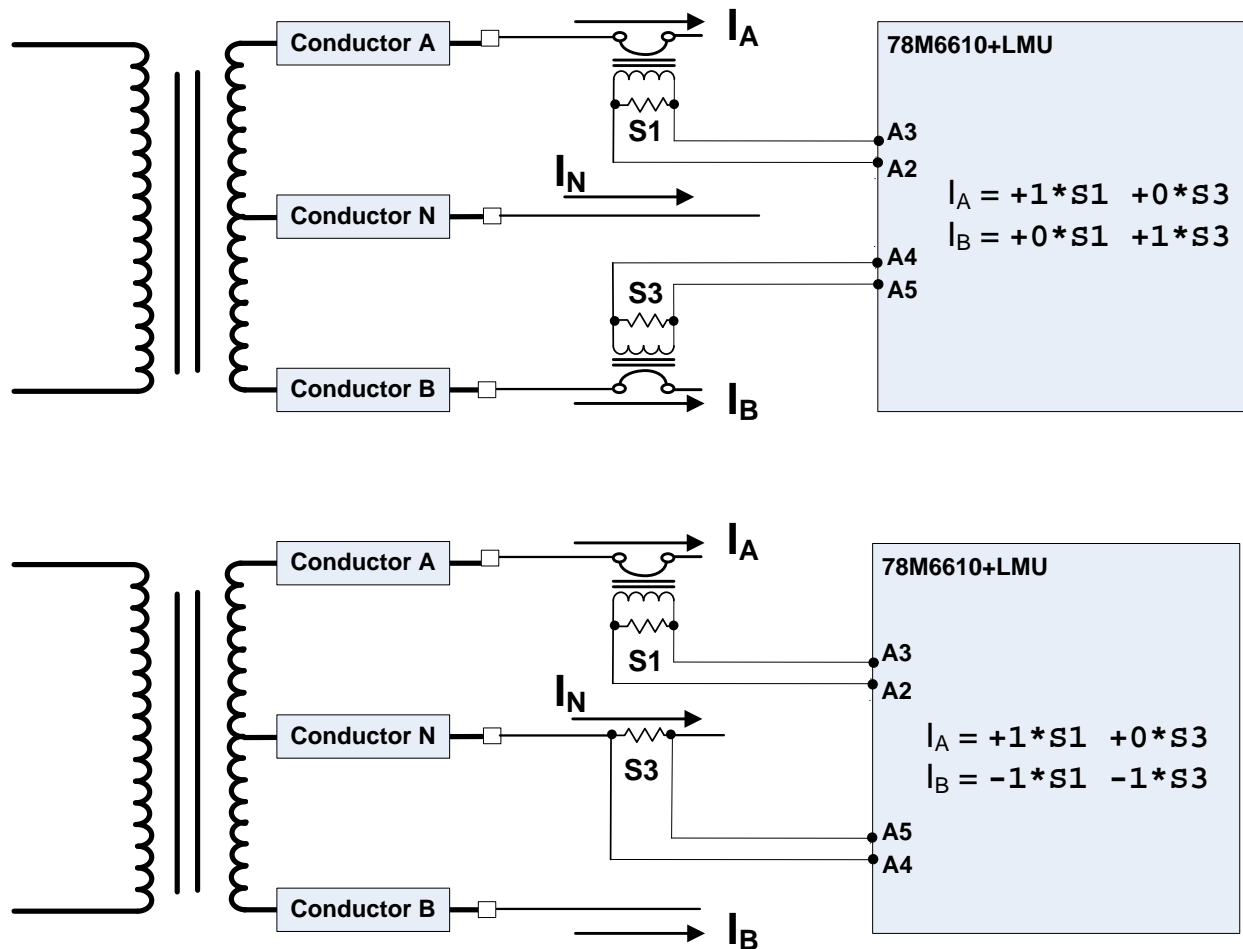

Figure 15. Current Configuration Examples

Pre-Amp

By default, the full-scale signal that can be applied to the current inputs is $V_{3P3A} \pm 250\text{mVpk}$ ($176.78\text{mV}_{\text{RMS}}$). This setting provides the widest dynamic range and is recommended for most applications.

For applications requiring a much lower value shunt resistor, an optional pre-amplifier with an 8x gain is included for the current inputs. The maximum input signal applied to the current inputs in this case would be $V_{3P3A} \pm 31.25\text{mVpk}$.

CONFIG[21:20]	00	01	10	11
8x Gain Enable	none	S1	S3	both

The gain is set by a ratio of internal resistors with one of the resistors in series from the input pad to the pre-amp itself. As such, the device must only be directly connected to a shunt with minimal resistance when using the pre-amp.

Current Input Flowchart

The figure below illustrates the computational flowchart for IA and IB. The values for current input configuration register can be saved in flash memory and automatically restored at power-on or reset.

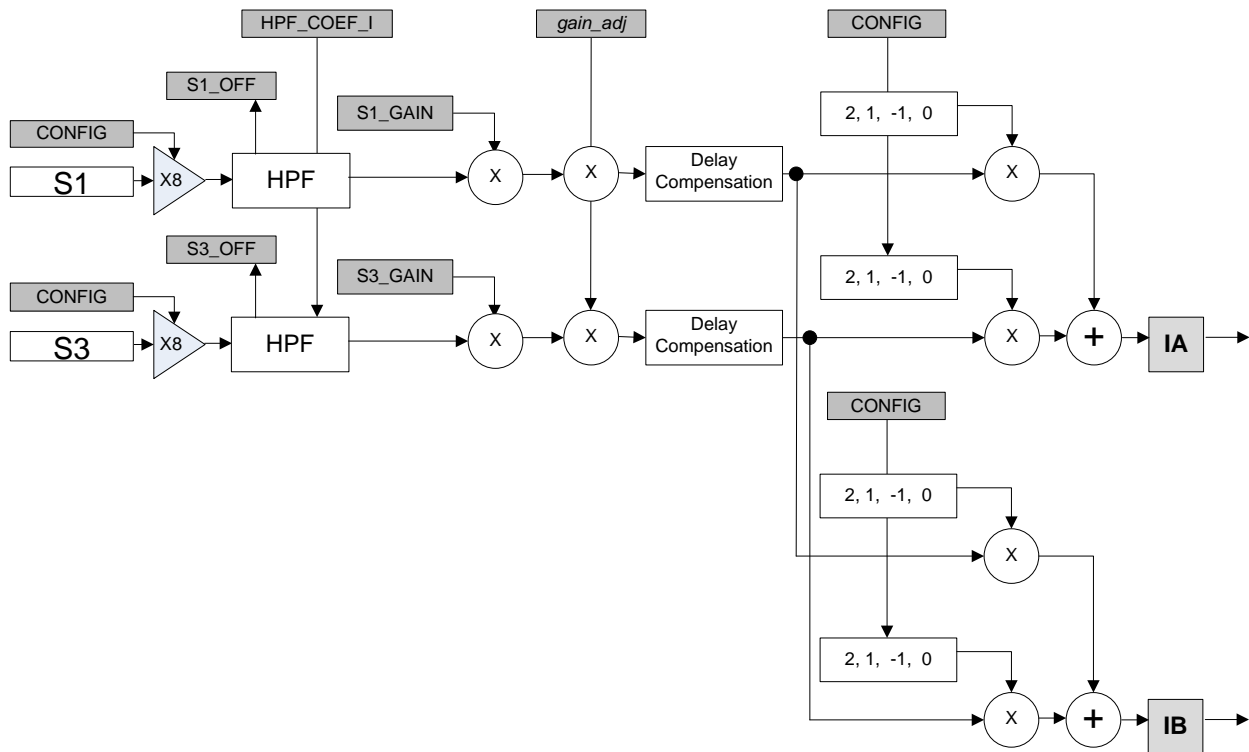

Figure 16. Current Input Flowchart

Data Refresh Rates

Instantaneous Voltage, Current, Power, and Quadrature measurement results are updated at the sample rate of 4kS/s and are generally not useful unless accessed with a high speed interface such as SPI. The CYCLE register is a 24-bit counter that increments every high-rate sample update and resets when low-rate results are updated.

Low-rate results, updated at a user configurable rate, are typically used and more suitable for most applications. The FRAME register is a counter that increments every accumulation interval. A data ready indicator in the STATUS register indicates when new data is available.

The high-rate samples are averaged to produce one low-rate result (known as an accumulation interval), increasing their accuracy and repeatability. Low-rate results include RMS voltages and currents, frequency, power, energy, and power factor. The accumulation interval can be based on a fixed number of ADC samples or locked to the incoming line voltage cycles.

If Line Lock is disabled, the accumulation interval defaults to a fixed time interval defined by the number of samples defined in the SAMPLES register (default of 400 samples or 0.1 seconds).

When the Line-Lock bit in the Command Register is set, and a valid AC voltage signal is present, the actual accumulation interval is stretched to the next positive zero crossing of the reference line voltage after the defined number of samples has been reached. If there is not a valid AC signal present and line lock is enabled, there is a 100 sample timeout implemented that would limit the accumulation interval to SAMPLES+100.

The DIVISOR register records the actual duration (number of high-rate samples) of the last low-rate interval whether or not Line-Lock is enabled.

Two bits in the CONFIG register allow the user to select the reference voltage slot for deriving zero-crossing detection and line frequency.

CONFIG[23:22]	00	01	10	11
Voltage reference	S0	S2	S0-S2	S0+S2

Scaling Registers

Most measurement data is reported in binary full-scale units with a value range of -1.0 to 1 - LSB. All full scale register readings correspond to the max analog input of 250mVpk (or 31.25mVpk with 8x gain). As an example, if 230V-peak at the input to the voltage divider gives 250mV-peak at the chip input, one would get a full scale register reading of 1 - LSB (0x7FFFFFFF) for instantaneous voltage. Similarly, if 30Apk at the sensor input provides 250mV-peak to the chip input, a full scale register value of 1 - LSB (0x7FFFFFFF) for instantaneous current would correspond to 30 amps. Full scale watts correspond to the result of full scale current and voltage so, in this example, full scale watts is 230 x 30 or 6900 watts.

Nonvolatile registers (IFSCALE and VFSCALE) are provided for storing the real-world current and voltage levels that apply to the full scale register readings for any given board design. Any host application can then format the measurement results to any data format as needed. The usage of these nonvolatile scratchpad registers is user defined and their content has no effect on the internal operations of the device.

Frequency data has a range of 0 to +32768Hz less one LSB (format S15.8). Temperature data has a fixed scaling with a range of -65536°C to +65536°C less one LSB (format S16.7). Energy data scaling is described in detail in section 2.10.

Calibration

The 78M6610+LMU provides integrated calibration routines to modify gain and offset coefficients. The user can set up and initiate a calibration routine through the Command Register. When in calibration mode, the line-lock bit should be set for best results.

The calibration routines will write the new coefficients to the relevant registers. The user can then save the new coefficients into flash memory as defaults using the flash access command in the Command Register.

See the [Command Register](#) section for more information on using commands.

Voltage and Current Gain Calibration

In order to calibrate the gain parameters for voltage and current channels, a reference AC signal must be applied to the channel to be calibrated. The RMS value corresponding to the applied reference signal must be entered in the relevant target register (VTARGET, ITARGET). Considering calibration is done with low-rate RMS results, the value of the target register should never be set to a value above 70.7% of full-scale.

Initially, the value of the gain is set to unity for the selected channels. RMS values are then calculated on all inputs and averaged over the number of measurement cycles set by the CALCYCS register. The new gain is calculated by dividing the appropriate Target register value by the averaged measured value. The new gain is then written to the select Gain registers unless an error occurred.

On a successful calibration, the command bits are cleared in the Command Register, leaving only the system setup bits. In case of a failed calibration, the bit in the Command Register corresponding to the failed calibration is left set.

Offset Calibration

To calibrate offset, all signals should be removed from all analog inputs although it is possible to do the calibration in the presence of AC signals. In the command, the user also specifies which channel(s) to calibrate. Target registers are not used for Offset calibration.

During the calibration process, each input is accumulated over the entire calibration interval as specified by the CALCYCS register. The result is divided by the total number of samples and written to the appropriate offset register if selected in the calibration command. Using the Offset Calibration command will set the respective HPF coefficients to zero thereby fixing the Sx_OFFS offset registers to their calibrated values. Upon completion of calibration, only the 0xCAXxxx bits of the Command Register are cleared.

Die Temperature Calibration

To re-calibrate the on-chip temperature sensor offset, the user must first write the known chip temperature to the T_TARGET register. Next, the user initiates the Temperature Calibration Command in the Command Register. This will update the T_OFFS offset parameter with a new offset based on the known temperature supplied by the user. The T_GAIN gain register is set by the factory and not updated with this routine. The range of the Die Temperature registers is -128 to +128 - LSB Degrees Celsius.

Voltage Channel Measurements

Instantaneous and quadrature voltage measurements are updated every sample while RMS Voltage and Peak Voltage are updated every accumulation interval (n samples). An AC voltage frequency measurement is also updated every low-rate interval.

Register	Description	Time Scale
VA VB VC	Instantaneous Voltage @ time t	1 sample
VQA VQB	Quadrature Voltage @ time t - 90°	
FREQ	AC Voltage Frequency	1 interval
VA_PEAK VB_PEAK	Peak Voltage in last interval	
VA_RMS VB_RMS VC_RMS	RMS Voltage of last interval	

Quadrature Voltage

The quadrature voltage is instantaneous voltage that is phase shifted (delayed) 90° from the respective input voltage.

Voltage Frequency

This output is a measurement of the fundamental frequency of the referenced AC voltage source with a range from 0Hz to 128Hz - LSB. This is a single reading per device.

Peak Voltage

This output is a capture of the largest magnitude instantaneous voltage source sample during the previous accumulation interval.

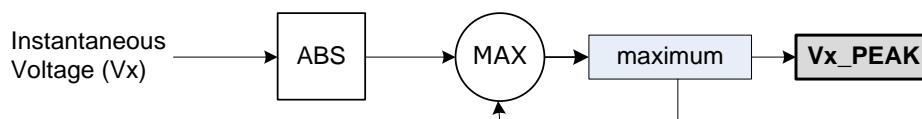

Figure 17. Peak Voltage Computation

RMS Voltage

The 78M6610+LMU reports true RMS measurements for each input. An RMS value is obtained by performing the sum of the squares of instantaneous values over a time interval (accumulation interval) and then performing a square root of the result after dividing by the number of samples in the interval.

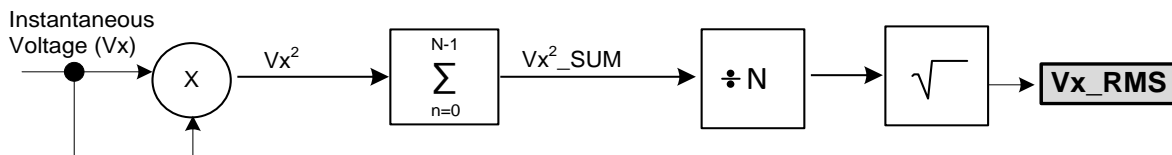

Figure 18. RMS Voltage Computation

Current Channel Measurements

In addition to instantaneous current measurements updated every sample, Peak Current, RMS Current, and Crest Factor are updated every accumulation interval (n samples).

Register	Description	Time Scale
IA IB	Instantaneous Current	1 sample
IA_PEAK IB_PEAK	Peak Current	1 interval
IA_RMS IB_RMS	RMS Current	
IA_CREST IB_CREST	Current Crest Factor	

Peak Current

This output is a capture of the largest magnitude instantaneous current load sample.

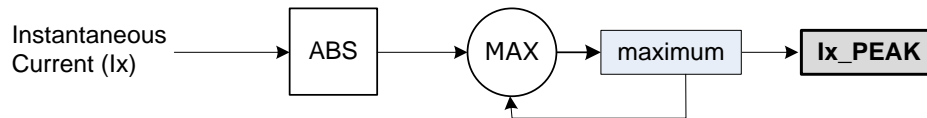

Figure 19. Peak Current Computation

RMS Current

The 78M6610+LMU reports true RMS measurements for current inputs. The RMS current is obtained by performing the sum of the squares of the instantaneous current samples over the accumulation interval and then performing a square root of the result after dividing by the number of samples in the interval.

An optional “RMS offset” for the current channels can be adjusted to reduce errors due to noise or system offsets (crosstalk) exhibited at low input amplitudes. Full scale values in the `IxRMS_OFFS` registers are squared and subtracted from the accumulated/divided squares. If the resulting RMS value is negative, zero is used.

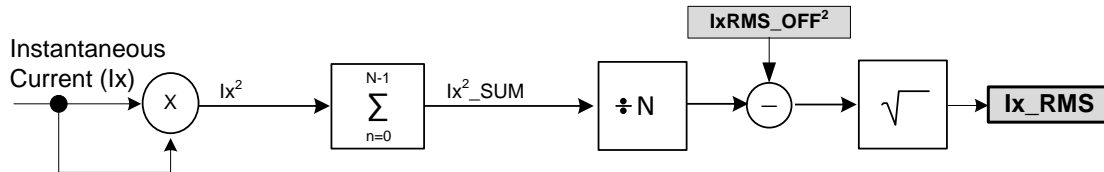

Figure 20. RMS Current Computation

Minimum Current

The device includes a squelch feature to report zero current for no-load conditions. When the RMS current value (checked at each accumulation interval) falls below the threshold (`IRMS_MIN`), the device will report zero current and prevent the continued accumulation of energy.

Register	Description
<code>IRMS_MIN</code>	If measured <code>Ix_RMS</code> is less than value in <code>IRMS_MIN</code> , then <code>Ix_RMS</code> is squelched and energy accumulation stops

Crest Factor

The crest factor outputs capture the result of the equation $Ix_CREST = Ix_PEAK / Ix_RMS$ for the most recent accumulation interval. They have a range of 0 to 256.

Power Calculations

This section describes the detailed flow of power calculations in the 78M6610+LMU. Generic equations for AC power measurement are listed in the table below.

Register	Description	Time Scale
PA PB	Instantaneous Active Power	1 sample
PQA PQB	Instantaneous Reactive Power	
WATT_A WATT_B WATT_C	Average Active Power (P)	1 interval
VAR_A VAR_B VAR_C	Average Reactive Power (Q)	
VA_A VA_B VA_C	Apparent Power (S)	
PFA PFB PFC	Power Factor	

NOTE: WATT_C, VAR_C and VA_C outputs are always scaled by a factor of 0.5.

Active Power (P)

The instantaneous power results (PA, PB) are obtained by multiplying aligned instantaneous voltage and current samples. The sum of these results are then averaged over N samples (accumulation time) to compute the average active power (WATT_A, WATT_B), and the aggregate average power (WATT_C).

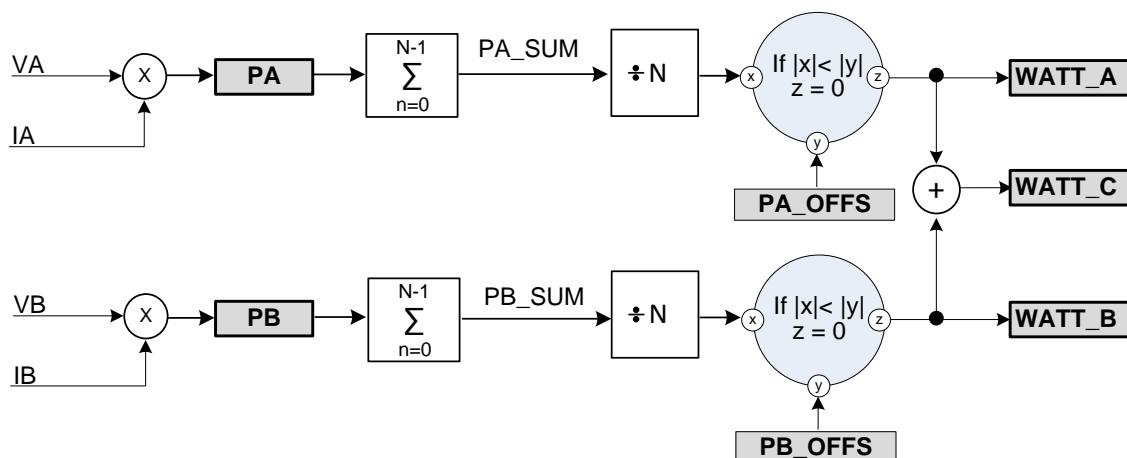

Figure 21. Active Power Computation

The value in the Px_OFFS register is the “Power Offset” for the power calculations. Full scale values in the Px_OFFS register are subtracted from the magnitude of the averaged active power. If the resulting active power value results in a sign change, zero watts are reported.

Reactive Power (Q)

Instantaneous reactive power results (PQA, PQB) are calculated by multiplying the instantaneous samples of current and the instantaneous quadrature voltage. The sum of these results are then averaged over N samples (accumulation time) to compute the average reactive power (VAR_A, VAR_B), and the aggregate average reactive power (VAR_C). A reactive power offset (Qx_OFFS) is also provided for each channel.

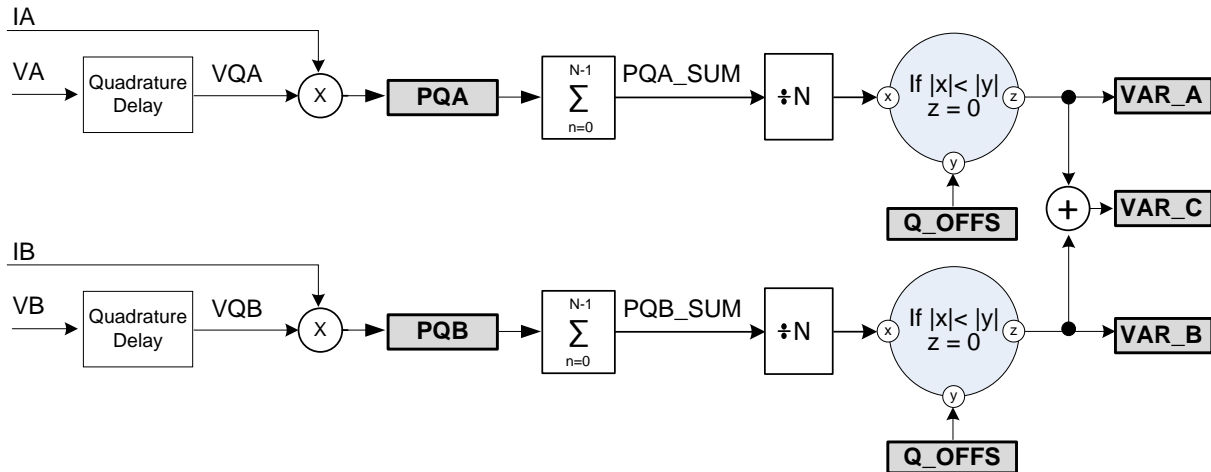

Figure 22. Reactive Power Computation

Apparent Power (S)

The apparent power, also referred as Volt-Amps, is the product of low-rate RMS voltage and current results. Offsets applied to RMS current will affect apparent power results.

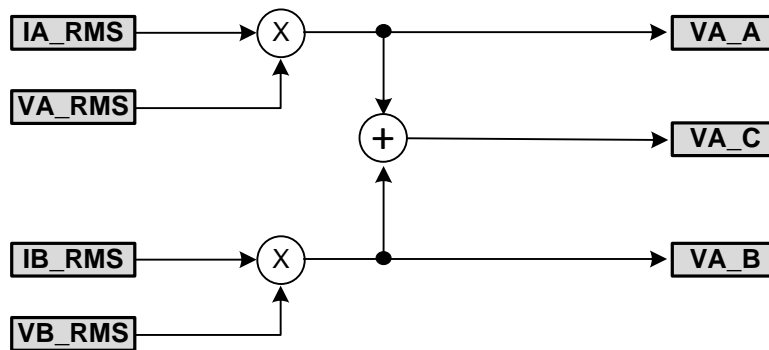

Figure 23. Apparent Power Computation

Power Factor (PF)

The power factor registers capture the ratio of active power to apparent power for the most recent accumulation interval. The sign of power factor is determined by the sign of active power.

$$PF_x = \frac{WATT_x}{VA_x}$$

Fundamental and Harmonic Calculations

The 78M6610+LMU includes the ability to separate low-rate voltage, current, active power, and reactive power measurement results into fundamental and total harmonic components. These outputs can also be used to track individual harmonics as well as the total value excluding the selected harmonic.

Register	Description	Time Scale
SINE COSINE	Instantaneous voltage of the internal waveform generator	1 sample
VFUND_A VFUND_B	Voltage content at specified harmonic	1 interval
IFUND_A IFUND_B	Current content at specified harmonic	
PFUND_A PFUND_B	Active Power content at specified harmonic	
QFUND_A QFUND_B	Reactive Power content at specified harmonic	
VHARM_A VHARM_B	Voltage content not at specified harmonic	
IHARM_A IHARM_B	Current content not at specified harmonic	
PHARM_A PHARM_B	Active Power content not at specified harmonic	
QHARM_A QHARM_B	Reactive Power content not at specified harmonic	

The HARM register is used to select the single harmonic to extract. This input register is set by default to 0x000001 selecting the first harmonic (also known as the fundamental frequency). This setting provides the user with fundamental result and the total harmonic distortion (THD) of the harmonics

By setting the value in the HARM register to a higher harmonic, the fundamental result registers will contain measurement results of the selected harmonic. Likewise, by setting the value in the HARM register to a higher harmonic, the harmonics result registers will report the measurement of the remaining harmonics. As an example, for any given accumulation interval, the magnitude of measurement result IA_RMS would be the sum of IFUND_A and IHARM_A.

The SINE and COSINE registers are high-rate registers updated every sample with the instantaneous value of the respective outputs from the internal Sine/Cosine generator. The referenced AC voltage frequency serves as the reference for the internal waveform generator.

Energy Calculations

Energy calculations are included in the 78M6610+LMU to minimize the traffic on the host interface and simplify system design. Low-rate power measurement results are multiplied by the number of samples (DIVISOR) to calculate the energy in the last accumulation interval. Energy results are summed together until a user defined “bucket size” is reached. When every bucket of energy is reached, the value in the energy counter register is incremented by one.

All energy counter registers are low-rate 24-bit output registers that contain values calculated over multiple accumulation intervals. Both import (positive) and export (negative) results are provided for active and reactive energy.

Register	Description
PA_POS_CNT PB_POS_CNT	Positive Active Energy Counter
PA_NEG_CNT PB_NEG_CNT	Negative Active Energy Counter
PQA_POS_CNT PQB_POS_CNT	Positive Reactive Energy Counter
PQA_NEG_CNT PQB_NEG_CNT	Negative Reactive Energy Counter
SA_CNT SB_CNT	Apparent Energy Counter

Energy results are cleared upon any power down or reset and can be manually cleared by the user using the CONTROL register. The CYCLES register can be used to detect device resets (loss of energy data) or to track time between energy reads. A bit in the STATUS register also indicates when a reset has occurred.

Bucket Size for Energy Counters

The BUCKET register allows the user to define the unit of measure for the energy counter registers. It is an unsigned 48-bit fixed-point number with 24 bits for the integer part and 24 bits for the fractional part.

	High Word							Low Word						
Bit Position	23	22	...	2	1	0	.	23	22	21	20	...	1	0
Value	2^{23}	2^{22}	...	2^2	2^1	2^0		2^{-1}	2^{-2}	2^{-3}	2^{-4}	...	2^{-23}	2^{-24}

The units should be set large enough to keep the accumulators and counters from overflowing too quickly. To increment the energy counters in watt-hours for example, the value in BUCKET should be equal to the number of seconds in an hour (3600) multiplied by the Sample Rate (4000) and divided by Full Scale Watts (VFSCALE x IFSCALE).

$$\text{Watt hours (Wh)} = \frac{3600s * 4000S/s}{VFSCALE * IFSCALE}$$

Full Scale Watts is defined by the sensors being used (see the [Scaling Registers](#) section). As an example, if the voltage sources are 400 volts-peak at full scale (VFSCALE) and the currents are 30 amps-peak at full scale (IFSCALE), then full scale watts would be 12000 watts (VFSCALE x IFSCALE). The bucket value can be saved to flash memory as the register default.

Example

In this example the scaling registers are set as follows:

VFSCALE = 667 (667V); IFSCALE = 50 (50A)

In order to set the energy bucket to one Wh:

$$\text{Bucket} = \frac{3600 * 4000}{667 * 50} = 431.784$$

The value to enter in the bucket register should be set as:

$$\text{Bucket Register} = 431.784 * 2^{24}$$

The value to set the bucket register is therefore:

High word = 0x0001AF; low word = 0xC8BB4C

Min/Max Tracking

The 78M6610+LMU provides a set of output registers for tracking the minimum and/or maximum values of up to six (6) different low-rate measurement results over multiple accumulation intervals. The user can select which measurements to track through an address table. MM_ADDR# uses word addressing for all host interfaces.

Register	Description	Time Scale
MM_ADDR0	Word addresses to track minimum and maximum values. A value of zero will disable tracking for that address slot.	-
MM_ADDR1		
MM_ADDR2		
MM_ADDR3		
MM_ADDR4		
MM_ADDR5		
MIN0	Minimum low-rate value at MM_ADDR#.	multiple intervals
MIN1		
MIN2		
MIN3		
MIN4		
MIN5		
MAX0	Maximum low-rate value at MM_ADDR#.	multiple intervals
MAX1		
MAX2		
MAX3		
MAX4		
MAX5		

Results are stored in RAM and cleared upon any power down or reset and can be manually cleared using the CONTROL register. A bit in the STATUS register is set whenever a MIN# or MAX# register is updated.

The address values in MM_ADDR# can be saved to flash memory by the user as the register defaults.

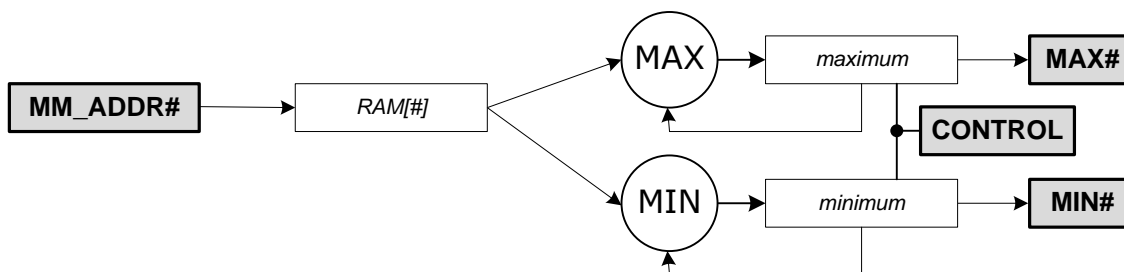

Figure 24. Min/Max Tracking

Alarm Monitoring

Low-rate alarm conditions are determined every accumulation interval. If results for Die Temperature, AC Frequency, or RMS Voltage exceeds or drops below user configurable thresholds, then a respective alarm bit in the STATUS register is set. For RMS Current and Watts results, maximum thresholds are provided for detecting over current or over power conditions with the load.

Register	Description
T_MAX	Threshold value which Temperature must exceed to trigger alarm.
T_MIN	Threshold value which Temperature must drop below to trigger alarm.
F_MAX	Threshold value which Frequency must exceed to trigger alarm.
F_MIN	Threshold value which Frequency must drop below to trigger alarm.
VRMS_MAX	Threshold value which RMS Voltage must exceed to trigger alarm.
VRMS_MIN	Threshold value which RMS Voltage must drop below to trigger alarm.
IRMS_MAX	Threshold value which RMS current must exceed to trigger alarm.
WATT_MAX	Threshold value which active power must exceed to trigger alarm.

Voltage Sag and Surge Detection

The 78M6610+LMU implements a voltage sag and surge detection function on both VA and VB. The sag/surge detection function can generate an alarm when the line voltage drops below or exceeds the relevant programmable thresholds.

The firmware calculates on a sample-by-sample basis the trailing mean square of the input voltage based on $\frac{1}{2}$ line cycle interval according to the following equation:

$$V_{MS} = \frac{f_{line}}{2 \times f_{sample}} \times \sum_{n=-int(\frac{f_{sample}}{2 \times f_{line}})}^0 v_n^2$$

At each sample interval the V_{MS} value is compared to a programmable threshold contained in the VSAG and VSURGE registers. If V_{MS} falls below or rises above the relevant thresholds, the firmware sets the relevant bits in the Alarms register.

The sample count for sag detection is automatically adjusted by the firmware to maintain coverage over half of the AC line cycle. Sag and surge detection is disabled by default and can be enabled by writing a nonzero value to the VSAG/VSURGE registers. If the VSAG/VSURGE registers are set to 0, the sag/surge feature is disabled.

The sag detection can be used to monitor or record the quality of the power line or utilize the sag a pin to notify external devices (for example a host microprocessor) of a pending power-down. The external device can then enter a power-down mode (for example saving data or recording the event) before a Power outage. The following figure shows a typical sag event.

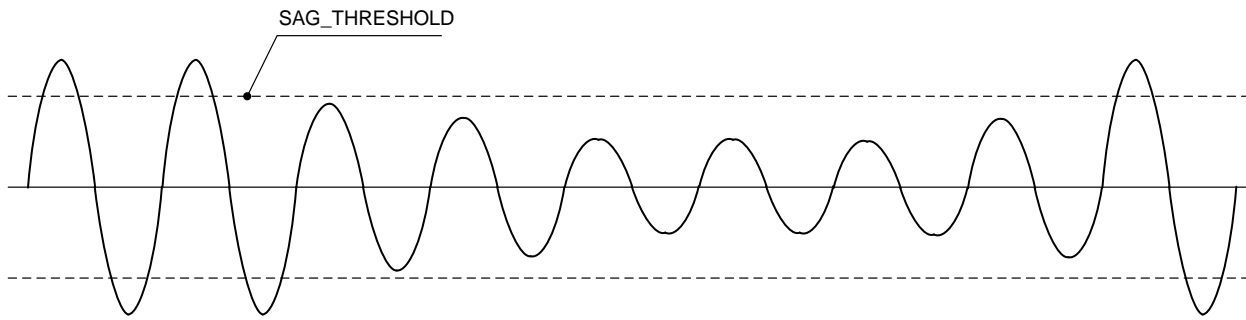
**Figure 25. Voltage Sag**

Register	Description
VSAG_VAL	Threshold value (in RMS) which voltage must go below to trigger a Sag alarm.
VSURG_VAL	Threshold value which voltage must go above to trigger alarm.

Status Registers

The STATUS register is used to monitor the status of the device and user configurable alarms. All other registers mentioned in this section share the same bit descriptions.

The STICKY register determines which alarm/status bits are sticky and which track the current status of the condition. Each alarm bit defined as sticky will (once triggered) hold its alarm status until the user clears it using the STATUS_RESET register. Any sticky bit not set will allow the respective status bit to clear when the condition clears.

The STATUS_SET and the STATUS_RESET registers allow the user to force status bits on or off respectively without fear of affecting unintended bits. A bit set in the STATUS_SET register will set the respective bit in the STATUS register and a bit set in the STATUS_RESET register will clear it. STATUS_SET and STATUS_RESET are both cleared after the status bit is set or reset.

The following table lists the bit mapping for all the status related registers.

Bit	Name	Stick-able	Description
23	DRDY	No	New low-rate results (data) ready
22	MMUPD	Yes	Min/Max Update occurred
21	VA_SAG	Yes	Voltage A Sag Condition Detected
20	VB_SAG	Yes	Voltage B Sag Condition Detected
19	SIGN_VA	No	Sign of VA
18	SIGN_VB	No	Sign of VB
17	OV_TEMP	Yes	Temperature over High Limit
16	UN_TEMP	Yes	Under Low Temperature Limit
15	OV_FREQ	Yes	Frequency over High Limit
14	UN_FREQ	Yes	Under Low Frequency Limit
13	OV_VRMSA	Yes	RMS Voltage A Over Limit
12	UN_VRMSA	Yes	RMS Voltage A Under Limit
11	OV_VRMSB	Yes	RMS Voltage B Over Limit
10	UN_VRMSB	Yes	RMS Voltage B Under Limit
9	VA_SURGE	Yes	Voltage A Surge Condition Detected
8	VB_SURGE	Yes	Voltage B Surge Condition Detected
7	OV_WATT1	Yes	Power 1 Over Limit
6	OV_WATT2	Yes	Power 2 Over Limit
5	OV_AMP1	Yes	Current 1 Over Limit
4	OV_AMP2	Yes	Current 2 Over Limit
3	XSTATE	No	Crystal status
2	RELAY1	Always	Relay 1 ON
1	RELAY2	Always	Relay 2 ON
0	RESET	Always	Set by device after any type of reset

Digital IO Functionality

The DIO_STATE register contains the current status of the DIOs. The user can use this register to read the state of a DIO (if configured as an input) or control the state of the DIO (if configured as an output). The DIO_DIR register sets the direction of the pins, where “1” is input and “0” is output. If a DIO defined as an input is unconnected, internal pullups will assert the respective DIO bit in the DIO_STATE register.

NOTE: Some pins are used as serial interface pins and may not be capable of user control. During reset, all DIOs are configured as inputs.

DIO Bit	SPI	UART	I ² C	MASK Register
0	MP0			MASK0
1	SCK	ADDR0	ADDR0	–
2	SDI	RXD	SDAI	–
3	SDO	TXD	SDAO	–
4	MP4			MASK4
5	SSB	RS485 DIR	SCL	–
6	MP6	ADDR1	ADDR1	MASK6
7	MP7			MASK7
8	IFC0			–
9	IFC1			–
10	MP10			MASK10
11:23	Reserved			

Interface configuration pins (IFC0, IFC1) and address pins (MP6/ADDR1, SCK/ADDR0) are input pins sampled at the end of a reset to select the serial host interface and set device addresses (for I²C and UART modes). If the IFC0 pin is low, the device will operate in the SPI mode. Otherwise, the state of IFC1 and the ADDR# pins determine the operating mode and device address.

These pins **MUST** remain configured as an input if directly connecting to GND/V_{3P3}. Otherwise, it is recommended to use external pullup or pulldown resistors accordingly.

DIO Polarity

DIOs configured as outputs are by default active LOW. The logic “0” state is ON. This can be modified using the DIO_POL register using the same bit definition as the DIO_STATE register. Any corresponding bit set in the DIO_POL register will invert the same DIO output so that it becomes active high.

Multipurpose (MP) Pins

The 78M6610+LMU provides five MASK registers for signaling the status of any STATUS bit to one of five multipurpose (MP) DIO pins. These MASK registers have the same bit mapping as the STATUS register. The user must first enable the respective MP pin as an output before the DIO can be driven to its active state.

Pin Name	Register	Description
MP0	MASK0	A combination of a bit set in both the STATUS register and a MASK register causes the assigned MP pin to be activated (default active-low).
MP4	MASK4	
MP6/ADDR1	MASK6	
MP7	MASK7	
MP10	MASK10	

Relay Control

If one of the RELAY bits in a MASK register is set, only the respective relay status bit in the STATUS register will change the state of the assigned MP pin. Two options are provided for controlling the state of the RELAY status bit:

1. Manual control of relay status using the STATUS_SET and STATUS_RESET registers.
2. Autonomous control determined by the state of other bits in the STATUS and MASK register. For example, if a MASK register has the RELAY1 and VA_SURGE bits set, a surge alarm on voltage source VA would assert the RELAY1 status bit.

The 78M6610+LMU includes a programmable delay for driving the MP pins from the MASK register when the relay bit is set. The relay control logic allows setting a delay time (increments of 250 μ s) for energizing (setting) and de-energizing (clearing) the relay pin relative to the zero crossing of the referenced voltage source. The time specified in the registers is expressed in number of high-rate samples. There is a pipeline delay of 1 sample introduced by the timers.

Registers	Description
RYA_TON RYB_TON	Relay turn-on delay following low-to-high transition of referenced voltage.
RYA_TOFF RYB_TOFF	Relay turn-off delay following high-to-low transition of referenced voltage.

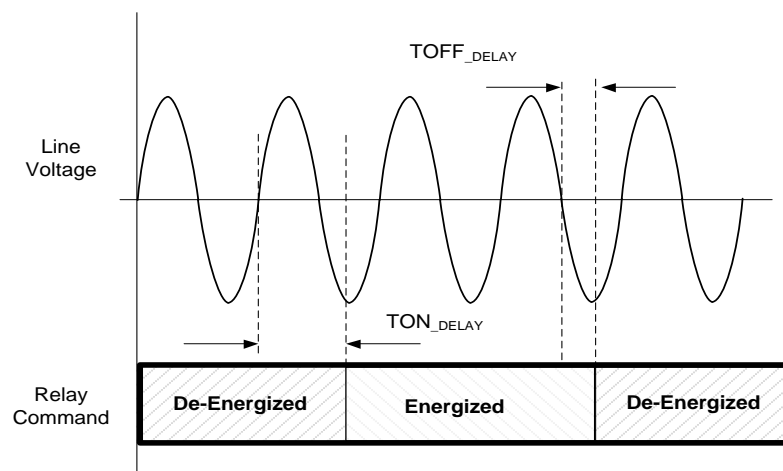

Figure 26. Relay Timing

Command Register

This register is used to issue commands to perform specific tasks to the device. Use of any command not listed in this document can cause unpredictable and possibly dangerous behavior.

General Settings

The general settings allows the user to enable functions such as UART auto reporting, relay operations, and Line Lock mode, etc. These settings are used with all other commands and are stored as non-volatile settings upon use of the Save to Flash Command (0xACC2xx).

Bit(s)	Value	Description
7	0	Not Used
6	FREQ	Stop Frequency update 1 = stop; 0 = update. This bit stops the update of FREQ used by the sine/cosine generator for fundamental and harmonic measurements. It is the unscaled value of Frequency with 8 integer and 16 fraction bits. The user can set the fundamental frequency when FREQ is set.
5	LL	Line Lock 1 = lock to line cycle; 0 = independent. This bit selects the accumulation interval (computation cycle) mode. If not locked the computation is executed over a fixed number of samples (high rate) contained in the Accum register. If locked, the computation is executed over a number of samples accumulation interval.
4	TC	Enable Gain/Temperature compensation 1 = enable; 0 = disable. This bit allows the firmware to modify the system gain based on measured temperature.
3:0	0	Reserved

No Action (0x00xxxx)

Allows the user to disable temperature updates.

Bit(s)	Value	Description
23:12	0x00	No Action
11	0	Not Used
10	T	Stop temperature update: 1 = stop; 0 = update. This bit prevents the firmware from overwriting the TempC (temperature result) register. This is necessary when supplying a known temperature for calibration.
9:8	0	Not Used
7:0		See General Settings.

Save to Flash Command (0xACC2xx)

Use this command to save to flash the calibration coefficients and system defaults contained in the some of the input registers. Upon reset or power-on, the values stored in flash becomes new system defaults. The General Settings bits ([7:0] are stored in nonvolatile storage while the upper 16 bits (23:16]) are stored as 0x0000 (No Action Command). When the process completes, bits [23:8] are cleared. The following table describes the command bits:

Bit(s)	Value	Description
23:12	0xACC	Access Command
11:8	0x2	Save non-volatile values to flash.
7:0		See General Settings (0x00xxxx).

Clear Flash Storage 0 Command (0xACC0xx)

Use this command to clear the flash coefficients (non-volatile system defaults for some of the input registers). Upon reset or power-on, the values revert to factory system defaults. This command should always be used in conjunction with Clear Flash Storage 1 Command (0xACC1xx). When the process completes, bits [23:8] are cleared.

Bit(s)	Value	Description
23:12	0xACC	“Access” Command
11:8	0x0	Clear non-volatile values in flash.
7:0		See General Settings (0x00xxxx).

Clear Flash Storage 1 Command (0xACC1xx)

Use this command to clear the flash coefficients (non-volatile system defaults for some of the input registers). Upon reset or power-on, the values revert to factory system defaults. This command should always be used in conjunction with Clear Flash Storage 0 Command (0xACC0xx). When the process completes, bits [23:8] are cleared.

Bit(s)	Value	Description
23:12	0xACC	“Access” Command
11:8	0x1	Clear non-volatile values in flash.
7:0		See General Settings (0x00xxxx).

Calibration Command (0xCAxxxx)

Use this command to start the calibration process for the selected inputs. It is assumed that appropriate input signals are applied before starting calibration. When the calibration process completes, bits [23:16] are cleared along with bits associated with channels that calibrated successfully. Any channels that failed will have their corresponding bit left set.

Bit(s)	Value	Description
23:16	0xCA	"Calibrate" Command.
15	0	Not Used (set to 0)
14	S2	Calibrate Voltage for Sensor 2
13	S0	Calibrate Voltage for Sensor 0
12	S3	Calibrate Voltage for Sensor 3
11	S1	Calibrate Voltage for Sensor 1
10	T	Calibrate Chip Temperature
9	O	Calibrate Offset (instead of gain) for Current or Voltage
8	XT	Calibrate External Temperature Gain
7:0		See General Settings (0x00xxxx)

Soft Reset (0xBDxxxx)

Allows the user to soft reset the device

Bit(s)	Value	Description
23:12	0xBD	Soft reset command
11:0	0	Not Used

Control Register

A CONTROL register is provided for resetting the tracked Energy and Min/Max measurement values and for clearing energy results.

Control Bit	Description
23:3	Reserved for future use
2	Clear Energy Accumulators and Frame Counter
1	Clear Energy Counters
0	Reset Min/Max Tracking

Configuration Register

The CONFIG register described throughout Section 2.1 allows the user to configure which sensor (slot) inputs are used for voltage and current measurements. This section summarizes the configuration bits available to the user.

The two MSBs select the reference voltage slot for deriving zero-crossing detection and line frequency.

CONFIG[23:22]	00	01	10	11
Voltage reference	S0	S2	S0-S2	S0+S2

The remaining bits configure which the sensor inputs are used to derive line voltages and load currents.

CONFIG Bits	19:18	17:16	15:14	13:12	11:10	9:8	7:6	5:4	3:2	1:0
Multiplier	M2	M0	M2	M0	M2	M0	M3	M1	M3	M1
Source	VC		VB		VA		IB		IA	

There are four choices for every M value as shown below. See Section 2.1 for more information.

Multiplier Bits	00	01	10	11
M (multiplier) Value	-1	0	1	2

Register Access

All user registers are contained in a 256-word (24-bits each) area of the on-chip RAM and can be accessed through the UART, SPI, or I²C interfaces. These registers are byte-addressable via the UART interface and word-addressable via the SPI, and I²C interfaces.

These registers consist of read (output), write (input), and read/write in the case of the Command Register.

Writing to reserved registers or to unspecified memory locations could result in device malfunction or unexpected results.

Data Types

The input and output registers have different data types, depending on their assignment and functions. The notation used indicates whether the number is signed, unsigned, or bit-mapped and the location of the binary point.

INT Indicates a 24-bit integer with a range of 0 to 16777215 typically used for counters or Boolean registers with 24 independent bit values.

S Indicates a signed fixed-point value.

. Indicates a fixed-point number.

nn Indicates the number of bits to the right of the binary point.

Example: S.21 is a 24-bit signed fixed-point number with 21 fraction bits to the right of the binary point and a range of -4.0 to $4 \cdot 2^{-21}$

Bit Position	23	22	21	.	20	19	18	17	...	2	1	0
Bit Multiplier	Sign bit (-2^2)	2^1	2^0		2^{-1}	2^{-2}	2^{-3}	2^{-4}	...	2^{-19}	2^{-20}	2^{-21}
Max Value	0	1	1		1	1	1	1	1	1	1	1
Min Value	1	0	0		0	0	0	0	0	0	0	0

Register Locations

Use Word addresses for I²C and SPI interfaces and Byte addresses for the SSI (UART) protocol.

Nonvolatile (NV) register defaults are indicated with a 'Y'. All other registers are initialized as described in the Functional Description.

Word Addr	Byte Addr	Register	Type	NV	Description
0	0	COMMAND	INT	Y	Command Register (see Command Register section)
1	3	FWDATE	INT		Firmware release date in hex format (0x00YMDD)
2	6	MASK0	INT	Y	Status bit mask for MP0 pin
3	9	MASK4	INT	Y	Status bit mask for MP4 pin
4	C	MASK6	INT	Y	Status bit mask for MP6 pin
5	F	MASK7	INT	Y	Status bit mask for MP7 pin
6	12	MASK10	INT	Y	Status bit mask for MP10 pin
7	15	STICKY	INT	Y	Status bits to hold until cleared by host
8	18	SAMPLES	INT	Y	High-Rate Samples per Low Rate (default 400)
9	1B	CALCYCS	INT	Y	Number of Calibration Cycles to Average
A	1E	PHASECOMP1	S.21	Y	Phase compensation (+/-4 samples) for S1 input
B	21	PHASECOMP3	S.21	Y	Phase compensation (+/- 4 samples) for S3 input
C	24	S1_GAIN	S.21	Y	Input S1 Gain Calibration. Positive values only
D	27	S0_GAIN	S.21	Y	Input S0 Gain Calibration. Positive values only
E	2A	S3_GAIN	S.21	Y	Input S3 Gain Calibration. Positive values only
F	2D	S2_GAIN	S.21	Y	Input S2 Gain Calibration. Positive values only
10	30	S1_OFFS	S.23	Y	Input S0 Offset Calibration
11	33	S0_OFFS	S.23	Y	Input S1 Offset Calibration
12	36	S3_OFFS	S.23	Y	Input S3 Offset Calibration
13	39	S2_OFFS	S.23	Y	Input S2 Offset Calibration
14	3C	T_GAIN	S.10	Y	Temperature Slope Calibration
15	3F	T_OFFS	S.10	Y	Temperature Offset Calibration
16	42	HPF_COEF_I	S.23	Y	Current Input HPF Coefficient. Positive values only
17	45	HPF_COEF_V	S.23	Y	Voltage Input HPF Coefficient. Positive values only
18	48	VSURG_INT	INT	Y	Voltage Surge Detect Interval
19	4B	VSAG_INT	INT	Y	Voltage Sag Detect Interval
1A	4E	STATUS	INT		Alarm and Device Status Bits
1B	51	STATUS_SET	INT		Used to Set Status bits
1C	54	STATUS_RESET	INT		Used to Reset Status bits
1D	57	DIO_STATE	INT		State of DIO pins
1E	5A	CYCLE	INT		High-Rate Sample Counter
1F	5D	FRAME	INT		48 bit Low-Rate Sample Number – Low word
20	60	FRAME	INT		48 bit Low-Rate Sample Number – High word
21	63	DIVISOR	INT		Actual samples in previous low-rate period
22	66	HARM	INT		Harmonic Selector, default: 1 (fundamental)
23	69	DEVADDR	INT	Y	High order address bits for I ² C and UART interfaces
24	6C	CONTROL	INT		Control (see text)
25	6F	CONFIG	INT	Y	Input Source M (gain) selectors and more
26	72	VTARGET	S.23	Y	Voltage Calibration Target. Positive values only
27	75	VSURG_VAL	S.23	Y	Voltage Surge Threshold. Positive values only
28	78	VSAG_VAL	S.23	Y	Voltage Sag Threshold. Positive values only

Word Addr	Byte Addr	Register	Type	NV	Description
29	7B	VRMS_MIN	S.23	Y	Voltage lower alarm limit. Positive values only
2A	7E	VRMS_MAX	S.23	Y	Voltage upper alarm limit. Positive values only
2B	81	VA_RMS	S.23		RMS Voltage for VA source
2C	84	VB_RMS	S.23		RMS Voltage for VB source
2D	87	VA_FUND	S.23		Fundamental Voltage for VA source
2E	8A	VB_FUND	S.23		Fundamental Voltage for VB source
2F	8D	VA_HARM	S.23		Harmonic Voltage for VA source
30	90	VB_HARM	S.23		Harmonic Voltage for VB source
31	93	VC_RMS	S.23		RMS Voltage for VC source
32	96	–	S.23		Reserved Output
33	99	VA	S.23		Instantaneous Voltage for VA source
34	9C	VB	S.23		Instantaneous Voltage for VB source
35	9F	VQA	S.23		Instantaneous Quadrature Voltage for VA source
36	A2	VQB	S.23		Instantaneous Quadrature Voltage for VB source
37	A5	VC	S.23		Instantaneous Voltage for VC source
38	A8	SINE	S.23		Reference Sine
39	AB	COSINE	S.23		Reference Cosine
3A	AE	VA_PEAK	S.23		Peak recorded voltage
3B	B1	VB_PEAK	S.23		Peak recorded voltage
3C	B4	ITARGET	S.23	Y	Current Calibration Target. Positive values only
3D	B7	IRMS_MIN	S.23	Y	RMS Current to squelch as zero. Positive values only
3E	BA	IA_RMS	S.23		RMS Current for IA source
3F	BD	IB_RMS	S.23		RMS Current for IB source
40	C0	IA_FUND	S.23		Fundamental Current for IA source
41	C3	IB_FUND	S.23		Fundamental Current for IB source
42	C6	IA_HARM	S.23		Harmonic Current for IA source
43	C9	IB_HARM	S.23		Harmonic Current for IB source
44	CC	IA	S.23		Instantaneous Current for IA source
45	CF	IB	S.23		Instantaneous Current for IB source
46	D2	IA_PEAK	S.23		Peak recorded voltage
47	D5	IB_PEAK	S.23		Peak recorded voltage
48	D8	IRMS_MAX	S.23	Y	Over Current alarm limit. Positive values only
49	DB	IARMS_OFFS	S.23	Y	RMS Current offset for IA. Positive values only
4A	DE	IBRMS_OFFS	S.23	Y	RMS Current offset for IB. Positive values only
4B	E1	WATT_A	S.23		Active Power for source A
4C	E4	WATT_B	S.23		Active Power for source B
4D	E7	WATT_C	S.23		Total Active Power
4E	EA	VA_A	S.23		Volt-Amperes for source A
4F	ED	VA_B	S.23		Volt-Amperes for source B
50	F0	VA_C	S.23		Total Volt-Amperes
51	F3	VAR_A	S.23		Reactive Power for source A
52	F6	VAR_B	S.23		Reactive Power for source B
53	F9	VAR_C	S.23		Total Reactive Power
54	FC	PFUND_A	S.23		Fundamental Active Power for source A
55	FF	PFUND_B	S.23		Fundamental Active Power for source B
56	102	PHARM_A	S.23		Harmonic Active Power for source A
57	105	PHARM_B	S.23		Harmonic Active Power for source B
58	108	QFUND_A	S.23		Fundamental Reactive Power for source A

Word Addr	Byte Addr	Register	Type	NV	Description
59	10B	QFUND_B	S.23		Fundamental Reactive Power for source B
5A	10E	QHARM_A	S.23		Harmonic Reactive Power for source A
5B	111	QHARM_B	S.23		Harmonic Reactive Power for source B
5C	114	PA	S.23		Instantaneous Active Power for source A
5D	117	PB	S.23		Instantaneous Active Power for source B
5E	11A	PQA	S.23		Instantaneous Reactive Power for source A
5F	11D	PQB	S.23		Instantaneous Reactive Power for source B
60	120	WATT_MAX	S.23	Y	Power alarm limit
61	123	PA_OFFS	S.23	Y	Active Power Offset for PA. Positive values only
62	126	QA_OFFS	S.23	Y	Reactive Power Offset for PQA. Positive values only
63	129	PB_OFFS	S.23	Y	Active Power Offset for PB. Positive values only
64	12C	QB_OFFS	S.23	Y	Reactive Power Offset for PQB. Positive values only
65	12F	PFA	S.22		Source A Power Factor
66	132	PFB	S.22		Source B Power Factor
67	135	PFC	S.22		Total Power Factor
68	138	–	INT		Reserved Input
69	13B	TEMPC	S.10		Chip Temperature
6A	13E	T_TARGET	S.10	Y	Temperature Calibration Target
6B	141	T_MIN	S.10	Y	Temperature lower alarm limit
6C	144	T_MAX	S.10	Y	Temperature upper alarm limit
6D	147	FREQ	S.16		Line Frequency
6E	14A	F_MIN	S.16	Y	Line Frequency lower alarm limit
6F	14D	F_MAX	S.16	Y	Line Frequency upper alarm limit
70	150	–	INT		Reserved Input
71	153	MIN1			Minimum Recorded Value 1
72	156	MIN2			Minimum Recorded Value 2
73	159	MIN3			Minimum Recorded Value 3
74	15C	MIN4			Minimum Recorded Value 4
75	15F	MIN5			Minimum Recorded Value 5
76	162	MIN6			Minimum Recorded Value 6
77	165	MAX1			Maximum Recorded Value 1
78	168	MAX2			Maximum Recorded Value 2
79	16B	MAX3			Maximum Recorded Value 3
7A	16E	MAX4			Maximum Recorded Value 4
7B	171	MAX5			Maximum Recorded Value 5
7C	174	MAX6			Maximum Recorded Value 6
7D	177	MM_ADDR1	INT	Y	Min/Max Monitor - Word Address 1
7E	17A	MM_ADDR2	INT	Y	Min/Max Monitor - Word Address 2
7F	17D	MM_ADDR3	INT	Y	Min/Max Monitor - Word Address 3
80	180	MM_ADDR4	INT	Y	Min/Max Monitor - Word Address 4
81	183	MM_ADDR5	INT	Y	Min/Max Monitor - Word Address 5
82	186	MM_ADDR6	INT	Y	Min/Max Monitor - Word Address 6
83	189	VFSCALE	INT	Y	(see Scaling Registers section)
84	18C	IFSCALE	INT	Y	(see Scaling Registers section)
85	18F	SCRATCH1	INT	Y	Extra Register for storing user info
86	192	SCRATCH2	INT	Y	Extra Register for storing user info
87	195	SCRATCH3	INT	Y	Extra Register for storing user info

Word Addr	Byte Addr	Register	Type	NV	Description
88	198	SCRATCH4	INT	Y	Extra Register for storing user info
89	19B	BUCKET	INT	Y	Energy Bucket Size – Low word
8A	19E	BUCKET	INT	Y	Energy Bucket Size – High word
8B	1A1	IA_CREST	S.16		Crest Factor for IA (positive values only)
8C	1A4	IB_CREST	S.16		Crest Factor for IB (positive values only)
8D	1A7	–	INT		Reserved Output
8E	1AA	–	INT		Reserved Output
8F	1AD	PA_POS_CNT	INT		Positive Active Energy Counter
90	1B0	–	INT		Reserved Output
91	1B3	–	INT		Reserved Output
92	1B6	PA_NEG_CNT	INT		Negative Active Energy Counter
93	1B9	–	INT		Reserved Output
94	1BC	–	INT		Reserved Output
95	1BF	PB_POS_CNT	INT		Positive Active Energy Counter
96	1C2	–	INT		Reserved Output
97	1C5	–	INT		Reserved Output
98	1C8	PB_NEG_CNT	INT		Negative Active Energy Counter
99	1CB	–	INT		Reserved Output
9A	1CE	–	INT		Reserved Output
9B	1D1	PQA_POS_CNT	INT		Leading Reactive Energy Counter
9C	1D4	–	INT		Reserved Output
9D	1D7	–	INT		Reserved Output
9E	1DA	PQA_NEG_CNT	INT		Lagging Reactive Energy Counter
9F	1DD	–	INT		Reserved Output
A0	1E0	–	INT		Reserved Output
A1	1E3	PQB_POS_CNT	INT		Leading Reactive Energy Counter
A2	1E6	–	INT		Reserved Output
A3	1E9	–	INT		Reserved Output
A4	1EC	PQB_NEG_CNT	INT		Lagging Reactive Energy Counter
A5	1EF	–	INT		Reserved Output
A6	1F2	–	INT		Reserved Output
A7	1F5	SA_CNT	INT		Apparent Energy Counter
A8	1F8	–	INT		Reserved Output
A9	1FB	–	INT		Reserved Output
AA	1FE	SB_CNT	I24		Apparent Energy Counter
AB	201	RYA_TON	I24	Y	Relay #1 turn-on delay
AC	204	RYB_TON	I24	Y	Relay #2 turn-on delay
AD	207	RYA_TOFF	INT	Y	Relay #1 turn-off delay
AE	20A	RYB_TOFF	INT	Y	Relay #2 turn-off delay
AF	20D	RYA_CNT	INT		Delay count for relay #1
B0	210	RYB_CNT	INT		Delay count for relay #2
B1	213	BAUD	INT	Y	Baud rate for UART interface
B2	216	DIO_POL	INT	Y	Polarity of DIO pins. 1 = Active High ; 0 = Active Low
B3	219	DIO_DIR	INT	Y	Direction of DIO pins. 1 = Input ; 0 = Output

Serial Interfaces

All user registers are contained in a 256-word (24-bits each) area of the on-chip RAM and can be accessed through the UART, SPI, or I²C interfaces. While access to a single byte is possible with some interfaces, it is highly recommended that the user access words (or multiple words) of data with each transaction.

Only one interface can be active at a time. The interface selection pins are sampled at the end of a reset sequence to determine the operating mode. The user should allow 10ms from a power-up or reset event to provide the firmware adequate time to sample the state of these pins. During this time the status of these pins must not change.

Interface Mode	IFC0	IFC1
SPI	0	X (don't care)
UART	1	0
I ² C	1	1

UART Interface

The device implements a simple serial interface (SSI) protocol on the UART interface that features:

- Support for single and multipoint communications
- Transmit (direction) control for an RS-485 transceiver
- Efficient use of a low bandwidth serial interface
- Data integrity checking

The default configuration is 38400 baud, 8-bit, no-parity, 1 stop-bit, no flow control. The value in the BAUD register determines the baud rate to be used. Example: To select a 9600 baud rate, the user writes a decimal 9600 to the BAUD register. The new rate will not take effect immediately. It must be saved to flash and will take effect at the next reset. The maximum BAUD value is 115200.

RS-485 Support

The SSB/DIR/SCL pin is used to drive an RS-485 transceiver output enable or direction pin. The implemented protocol supports a full-duplex 4-wire RS-485 bus.

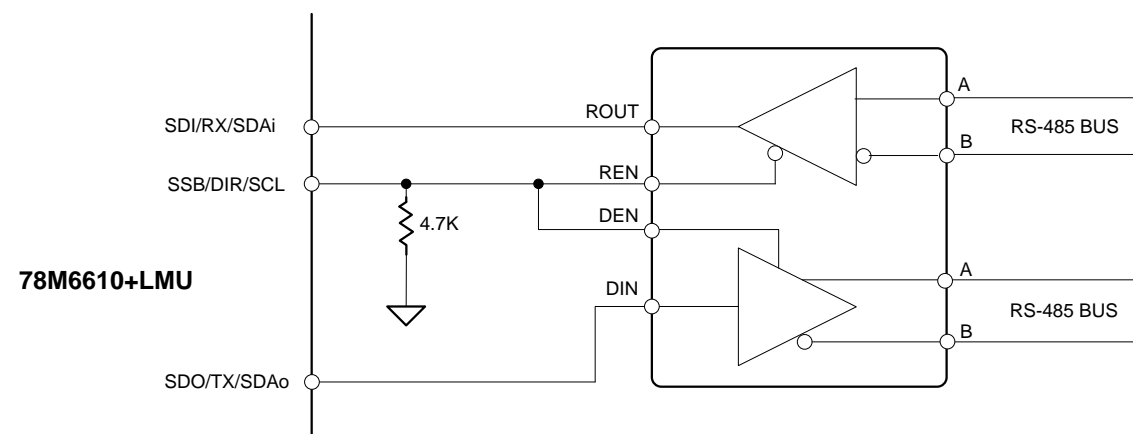

Figure 27. RS-485 Interface

Device Address Configuration

The SSI protocol utilizes 8-bit addressing for multipoint communications. The usable SSI ID range is 1 to 255. In multipoint systems with more than 4 targets, the user must configure device address bits in the DEVADDR according to the formula $\text{SSI ID} = \text{Device Address} + 1$.

A device address of 'FF' is not supported. DEVADDR [23:6] bits are not used and must be set to 1.

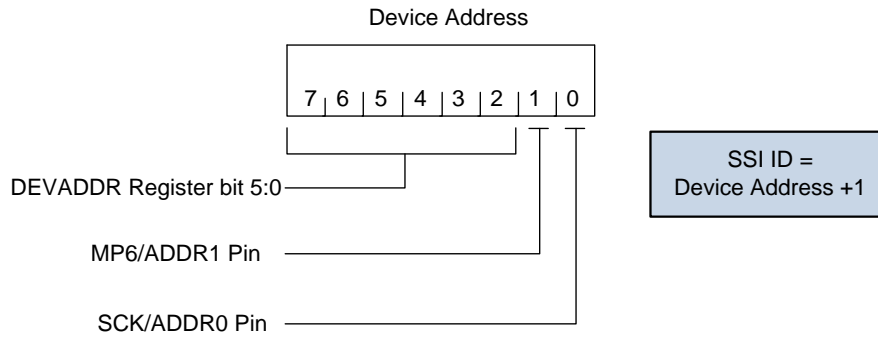

Figure 28. Device Address Configuration

SSI Protocol Description

The SSI protocol is command response system supporting a single master and one or more targets. The host (master) sends commands to a selected target that first verifies the integrity of the packet before sending a reply or executing a command. Failure to decode a host packet will cause the selected target to send a fail code. If the condition of a received packet is uncertain, no reply is sent.

Each target must have a unique SSI ID. Zero is not a valid SSI ID for a target device as it is used by the host to de-select all target devices.

With both address pins low on the 78M6610+LMU, the SSI ID defaults to 1 and is the “Selected” device following a reset. This configuration is intended for single target (point-to-point) systems that do not require the use of device addressing or selecting targets.

In multipoint systems, the master will typically de-select all target devices by selecting SSI ID #0. The master must then select the target with a valid SSI ID and get an acknowledgement from the slave before setting the target’s register address pointer and performing read or write operations. If no target is selected, no reply is sent. The SSB/DIR/SCL pin is asserted while the device is selected. The sequence of operation is shown in the following diagram.

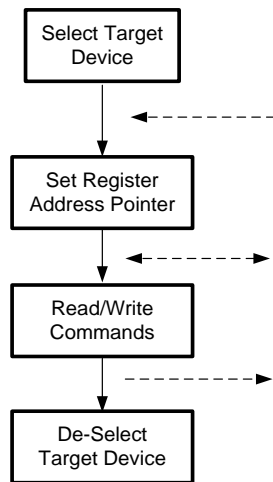

Figure 29. SSI Protocol

Master Packets

Master packets always start with the 1-byte header (0xAA) for synchronization purposes. The master then sends the byte count of the entire packet (up to 255 byte packets) followed by the payload (up to 253 bytes) and a 1-byte modulo-256 checksum of all packet bytes for data integrity checking.

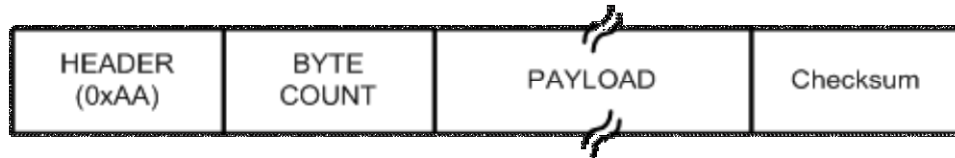

Figure 30. Master Packet Structure

The payload can contain either a single command or multiple commands if the target is already selected. It can also include device addresses, register addresses, and data. All multibyte payloads are sent and received least-significant-byte first.

Master Packet Command Summary

Command	Parameters	Description
0 - 7F		(invalid)
80 - 9F		(not used)
A0		Clear address
A1	[byte-L]	Set Read/Write address bits [7:0]
A2	[byte-H]	Set Read/Write address bits [15:8]
A3	[byte-L][byte-H]	Set Read/Write address bits [15:0]
A4 - AF		(reserved for larger address targets)
B0 - BF		(not used)
C0		De-select Target (target will Acknowledge)
C1 - CE		Select target 1 to 14 (target will Acknowledge)
CF	[byte]	Select target 0 to 255 (target will Acknowledge)
D0	[data...]	Write bytes set by remainder of Byte Count
D1 - DF	[data...]	Write 1 to 15 bytes
E0	[byte]	Read 0 to 255 bytes
E1 - EF		Read 1 to 15 bytes
F0 - FF		(not used)

Users only need to implement commands they actually need or intend to use. For example, only one address command is required – either 0xA1 for systems with 8 address bits or less or 0xA3 for systems with 9 to 16 address bits. Likewise, only one write, read, or select target command needs to be implemented. Select Target is not needed in systems with only one target.

Command Payload Examples

Device Selection

PAYLOAD	
0xCF Command	SSI ID

Register Address Pointer Selection

PAYLOAD	
0xA3 Command	Register Address (2 Bytes)

Small Read Command (3 bytes)

PAYLOAD
0xE3 Command

Large Read Command (30 bytes)

PAYLOAD	
0xE0 Command	0x1E (30 bytes)

Small Write Command (3 bytes)

PAYLOAD	
0xD3 Command	3 Bytes of Data

Large Write Command (30 bytes)

Byte Count	PAYLOAD	
0x21 (34 bytes)	0xD0 Command	30 Bytes of Data

After each read or write operation, the internal address pointer is incremented to point to the address that followed the target of the previous read or write operation.

Slave Packets

The type of slave packet depends upon the type of command from the master device and the successful execution by the slave device. Standard replies include “Acknowledge” and “Acknowledge with Data”.

ACKNOWLEDGE without data

ACKNOWLEDGE with data	BYTE COUNT	READ DATA	CHECK SUM
--------------------------	---------------	--------------	--------------

If no data is expected from the slave or there is a fail code, a single byte reply is sent. If a successfully decoded command is expected to reply with data, the slave sends a packet format similar to the master packet where the header is replaced with a Reply Code and the payload contains the read data.

Reply Code	Definition
0xAA	Acknowledge with data
0xAB	Acknowledge with data (half duplex)
0xAD	Acknowledge without data.
0xB0	Negative Acknowledge (NACK).
0xBC	Command not implemented.
0xBD	Checksum failed.
0xBF	Buffer overflow (or packet too long).
- timeout -	Any condition too difficult to handle with a reply.

Failure to decode a host packet will cause the selected target to send a fail code (0xB0 – 0xBF) acknowledgement depending on mode of failure. Masters wishing to simplify could accept any unimplemented fail code as a Negative Acknowledge.

If no target is selected or the condition of a received packet is uncertain, no reply is sent. Timeouts can also occur when data is corrupt or no target is selected. The master should implement the appropriate timeout control logic after approximately 50 byte times at the current baud rate. When a first reply byte is received, the master should check to see if it is an SSI header or an Acknowledge. If so, the timeout timer is reset, and each subsequent receive byte will also reset the timer. If no byte is received within the timeout interval, the master can expect the slave timed out and re-send a new command.

SPI Interface

The Maxim device operates as a SPI slave. The host is expected to instigate and control all transactions. The signals used for SPI communication are defined as:

- **SSB** : (also known as **CSB**) the device SPI chip/slave select signal (active low)
- **SCK** : the clocking signal that clocks **MISO** and **MOSI** (data)
- **SDI** : (also known as **MOSI**) the data shifted into the measurement device
- **SDO** : (also known as **MISO**) the data shifted out of the measurement device

In Maxim embedded measurement devices, these signals may have alternate functionality depending upon the device mode and/or firmware.

SPI Mode

The device operates as a slave in mode 3 (CPOL=1,CPHA==1) and as such the data is captured on the rising edge and propagated on the falling edge of the serial data clock(SCK). **Error! Reference source not found.** shows a single-byte transaction on the SPI bus. Bytes are transmitted/received MSB first.

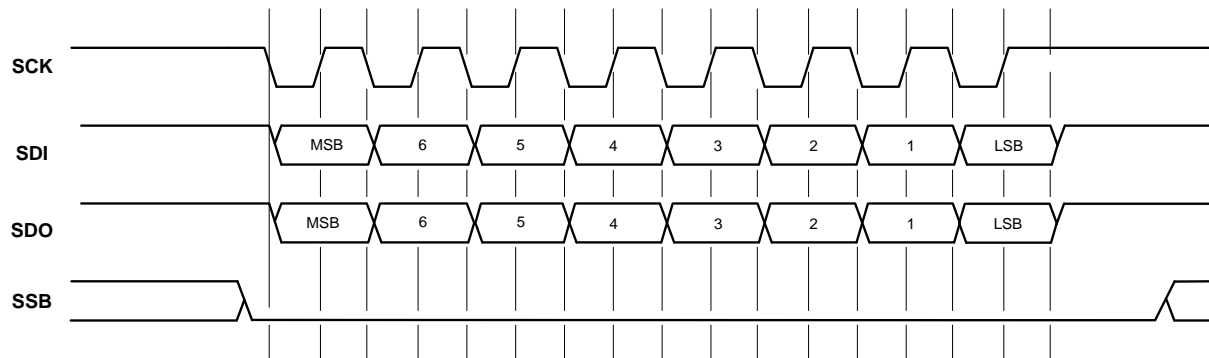

Figure 31: Signal Timing on the SPI Bus

Single Word SPI Reads

The device supplies direct read access to the device RAM memory. To read the RAM the master device must send a read command to the slave device and then clock out the resulting read data. SSB must be kept active low for the entire read transaction (command and response). SCK may be interrupted as long as SSB remains low. ADDR[5:0] is filled with the word address of the read transaction. RAM data contents are transmitted most significant byte first. ADDR[5:0] cannot exceed 0x3F. RAM words, and therefore the results, are natively 24 bits (3 bytes) long.

Byte Number	Bit 7	Bit 6	Bit 5	Bit 4	Bit 3	Bit 2	Bit 1	Bit 0
0	0x01							
1	ADDR[5:0]						0x0	
2	0							
3	0							
4	0							

Single Word SPI Read Command (SDI)

The slave responds with the data contents of the requested RAM addresses.

Byte Number	Bit 7	Bit 6	Bit 5	Bit 4	Bit 3	Bit 2	Bit 1	Bit 0
0	Hi-Z (during Read Command)							
1	Hi-Z (during Read Command)							
2	DATA[23:16] @ ADDR							
3	DATA[15:8] @ ADDR							
4	DATA[7:0] @ ADDR							

Single Word SPI Read Response (SDO)

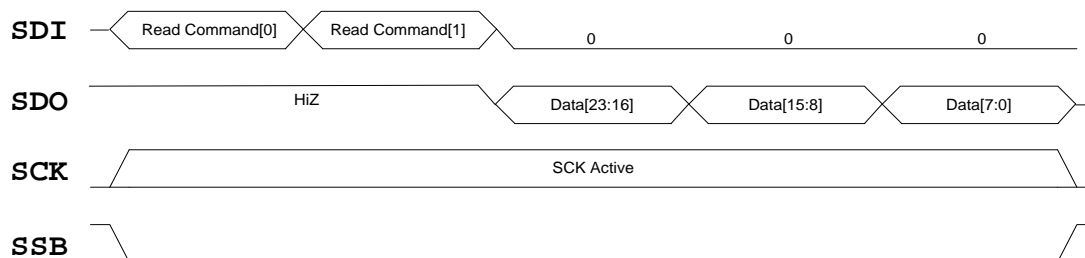

Figure 32: Single Word Read Access Timing

Single Word SPI Writes

The device supplies direct write access to the device RAM memory. To write the RAM the master device must send a write command to the slave device and then clock out the write data. SSB must be kept active low for the entire write transaction (command and data). SCK may be interrupted as long as SSB remains low. ADDR[5:0] is filled with the word address of the write transaction. RAM data contents are transmitted most significant byte first. ADDR[5:0] cannot exceed 0x3F. RAM words are natively 24 bits (3 bytes) long.

Byte Number	Bit 7	Bit 6	Bit 5	Bit 4	Bit 3	Bit 2	Bit 1	Bit 0
0	0x01							
1	ADDR[5:0]						0x02	
2	DATA[23:16] @ ADDR							
3	DATA[15:8] @ ADDR							
4	DATA[7:0] @ ADDR							

Single Word SPI Write Command and Data (SDI)

The slave SDO remains Hi-Z during a write access.

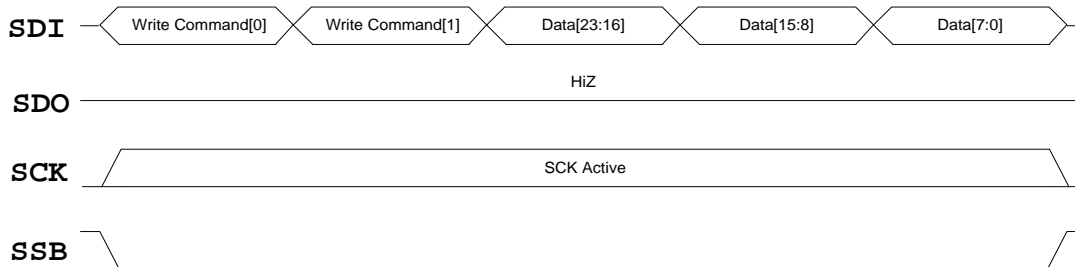

Figure 33: Single Word Write Access Timing

I²C Interface

The 78M6610+LMU has an I²C interface available at the SDAi, SDAo, and SCK pins. The interface supports I²C slave mode with a 7-bit address and operates at a data rate up to 400kHz. The figure below shows two possible configurations. Configuration A is the standard configuration. The double pin for SDA also allows for isolated configuration B.

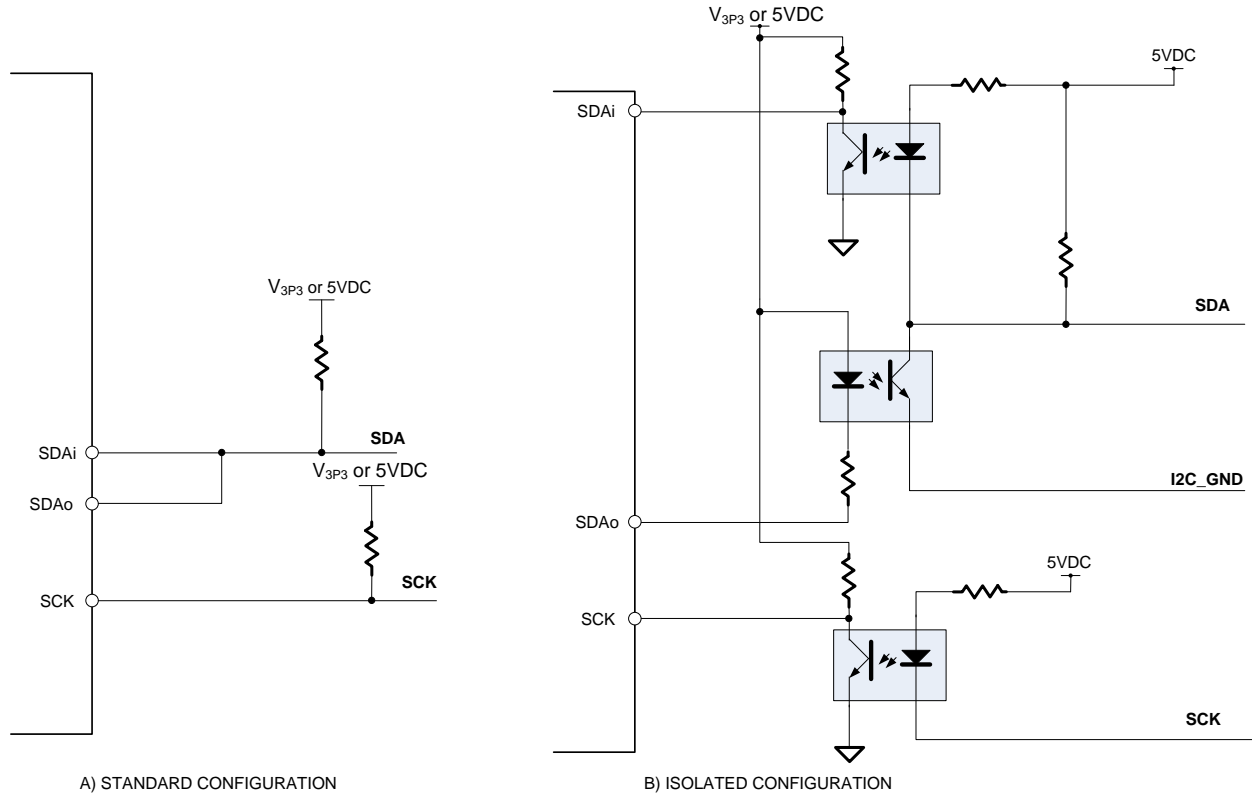

Figure 34. I²C Interface

Device Address Configuration

By default, there are only four possible addresses for the 78M6610+LMU as defined by two external address pins. To expand the potential address of the device to the entire 7-bit address range for I²C, one must first set bits [11:5] in the DEVADDR register. Bits 6 through 2 of the device address can then be defined by the lower 5-bits of the DEVADDR register (bits 4:0).

DEVADDR bits 23 through 5 are not used and must be set to 1.

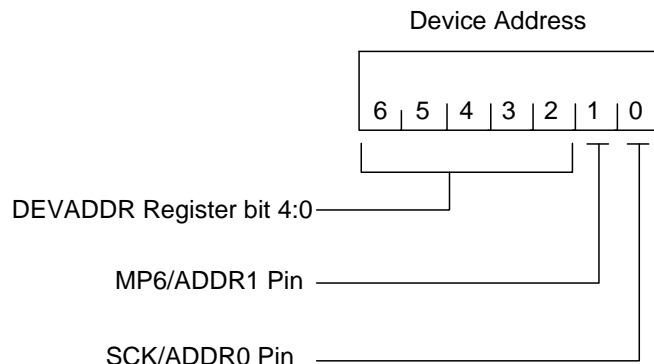

Figure 35. I²C Device Address

Bus Characteristics

- A data transfer may be initiated only when the bus is not busy.
- During data transfer, the data line must remain stable whenever the clock line is HIGH. Changes in the data line while the clock line is HIGH will be interpreted as a START or STOP condition.

Bus Conditions:

- **Bus Not Busy (I):** Both data and clock lines are HIGH indicating an Idle Condition.
- **Start Data Transfer (S):** A HIGH to LOW transition of the SDA line while the clock (SCL) is HIGH determines a START condition. All commands must be preceded by a START condition.
- **Stop Data Transfer (P):** A LOW to HIGH transition of the SDA line while the clock (SCL) is HIGH determines a STOP condition. All operations must be ended with a STOP condition.
- **Data Valid:** The state of the data line represents valid data when, after a START condition, the data line is stable for the duration of the HIGH period of the clock signal. The data on the line must be changed during the LOW period of the clock signal. There is one clock pulse per bit of data. Each data transfer is initiated with a START condition and terminated with a STOP condition.
- **Acknowledge (A):** Each receiving device, when addressed, is obliged to generate an acknowledge after the reception of each byte. The master device must generate an extra clock pulse, which is associated with this Acknowledge bit. The device that acknowledges has to pull down the SDA line during the acknowledge clock pulse in such a way that the SDA line is stable LOW during the HIGH period of the acknowledge-related clock pulse. Of course, setup and hold times must be taken into account. During reads, a master must signal an end of data to the slave by not generating an Acknowledge bit on the last byte that has been clocked out of the slave. In this case, the slave (78M6610+LMU) will leave the data line HIGH to enable the master to generate the STOP condition.

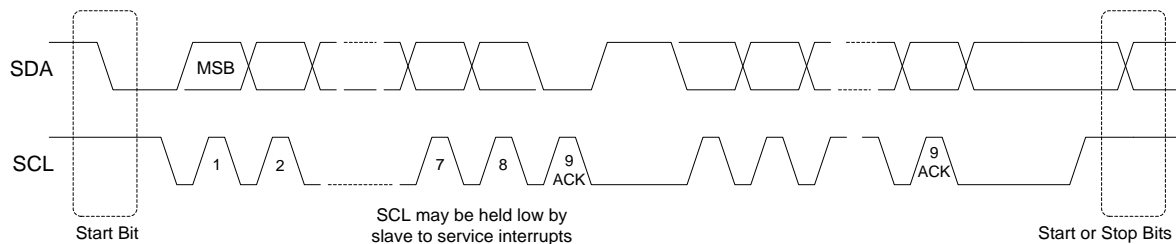

Figure 36. I²C Bus Characteristics

Device Addressing

A control byte is the first byte received following the START condition from the master device. The control byte consists of a seven bit address and a bit (LSB) indicating the type of access (0 = write; 1 = read).

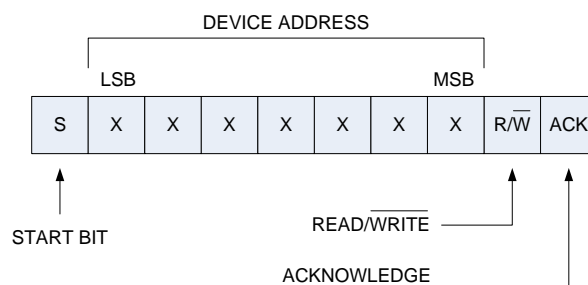

Figure 37. I²C Device Addressing

Write Operations

Following the START (S) condition from the master, the device address (7-bits) and the R/w bit (logic low for write) are clocked onto the bus by the master. This indicates to the addressed slave receiver that the register address will follow after it has generated an acknowledge bit (A) during the ninth clock cycle. Therefore, the next byte transmitted by the master is the register address and will be written into the address pointer of the 78M6610+LMU. After receiving another acknowledge (A) signal from the 78M6610+LMU, the master device will transmit the data byte(s) to be written into the addressed memory location. The data transfer ends when the master generates a stop (P) condition. This initiates the internal write cycle. The example below shows a 3-byte data write (24-bit register write).

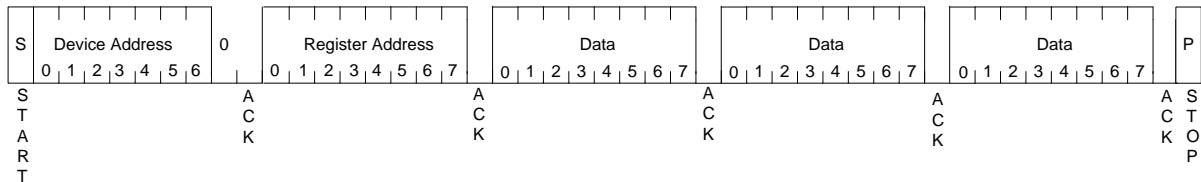

Figure 38. Write Operation Single Register

Upon receiving a STOP (P) condition, the internal register address pointer will be incremented. The write access can be extended to multiple sequential registers. The figure below shows a single transaction with multiple registers written sequentially.

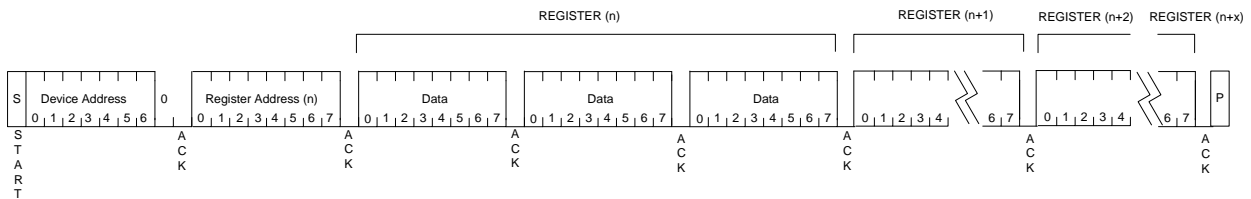

Figure 39. Write Operation Multiple Registers

Read Operations

Read operations are initiated in the same way as write operations with the exception that the R/w bit of the control byte is set to one. There are two basic types of read operations: current address read and random read.

Current Address Read: the 78M6610+LMU contains an address counter that maintains the address of the last register accessed, internally incremented by one when the stop bit is received. Therefore, if the previous read access was to register address n, the next current address read operation would access data from address n + 1.

Upon receipt of the control byte with R/w bit set to one, the 78M6610+LMU issues an acknowledge (A) and transmits the eight bit data byte. The master will not acknowledge the transfer, but generates a STOP condition to end the transfer and the 78M6610+LMU will discontinue the transmission.

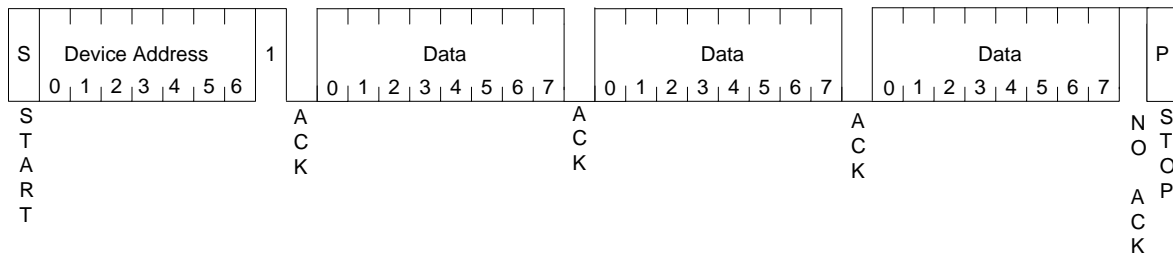

Figure 40. Read Operation

This read operation is not limited to 3 bytes but can be extended until the register address pointer reaches its maximum value. If the register address pointer has not been set by previous operations, it is necessary to set it issuing a command as follows:

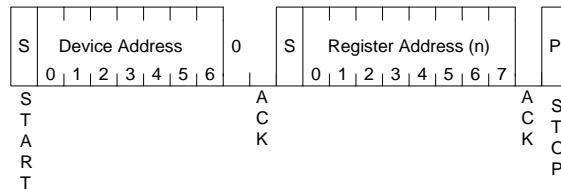

Figure 41. Setting Read Address

Random Read: random read operations allow the master to access any register in a random manner. To perform this operation, the register address must be set as part of the write operation. After the address is sent, the master generates a start condition following the acknowledge response. This sequence completes the write operation. The master should issue the control byte again this time, with the R/w bit set to 1 to indicate a read operation. The 78M6610+LMU will issue the acknowledge response, and transmit the data. At the end of the transaction the master will not acknowledge the transfer and generate a STOP condition.

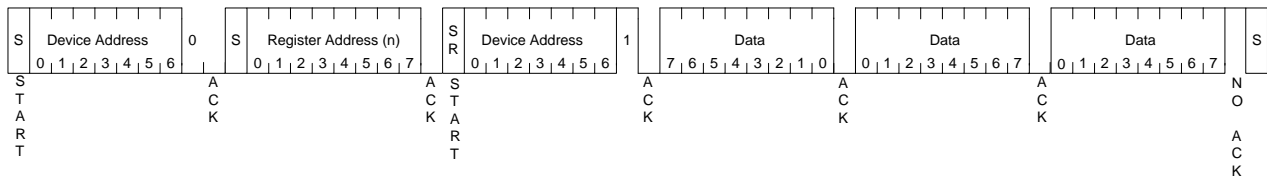

Figure 42. Reading Multiple Registers

This read operation is not limited to 3 bytes but can be extended until the register address pointer reaches its maximum value.

78M6610+LMU/B48

The 78M6610+LMU/B48 part is a 78M6610+LMU programmed with modified firmware and released under a unique ordering part number. The differences from standard LMU release (B01) are described below:

UART Interface

The default configuration is 4800 baud, 8-bit, no-parity, 1 stop-bit, no flow control.

Status Registers

The STATUS_SET and the STATUS_RESET registers are checked and acted upon every high rate sample time.

Command Register

The default value for the command register is 0x000020.

Config Register

The default value for the Config register is 0x29696.

Ordering Information

PART	TEMP RANGE	PIN-PACKAGE	TOP MARK
78M6610+LMU/B01	-40°C to +85°C	24 QFN	EMP
78M6610+LMU/B01T	-40°C to +85°C	24 QFN	EMP
78M6610+LMU/B48	-40°C to +85°C	24 QFN	EMP
78M6610+LMU/B48T	-40°C to +85°C	24 QFN	EMP

+Denotes a lead(Pb)-free/RoHS-compliant package.

T = Tape and reel.

Contact Information

For more information about the 78M6610+LMU or other Maxim Integrated products, go to:

www.maximintegrated.com/support.

Revision History

REVISION NUMBER	REVISION DATE	DESCRIPTION	PAGES CHANGED
0	1/13	Initial release	—
1	4/14	Updated Command Register and SPI Interface sections	42–45, 57–59
2	8/14	Updated Storage Temperature parameter on the Electrical Characteristics table and SPI Interface section	5, 57–59
3	10/15	Added <i>78M6610+LMU/B48</i> section to data sheet and <i>Ordering Information</i>	64, 65

Maxim Integrated cannot assume responsibility for use of any circuitry other than circuitry entirely embodied in a Maxim Integrated product. No circuit patent licenses are implied. Maxim Integrated reserves the right to change the circuitry and specifications without notice at any time. The parametric values (min and max limits) shown in the Electrical Characteristics table are guaranteed. Other parametric values quoted in this data sheet are provided for guidance.

Maxim Integrated 160 Rio Robles, San Jose, CA 95134 USA 1-408-601-1000

67

© 2015 Maxim Integrated Products, Inc. Maxim Integrated and the Maxim Integrated logo are trademarks of Maxim Integrated Products, Inc.

X-ON Electronics

Largest Supplier of Electrical and Electronic Components

Click to view similar products for [Metering Systems on a Chip - SoC category](#):

Click to view products by [Maxim manufacturer](#):

Other Similar products are found below :

[71M6521FE-IM/F](#) [78M6613-IMFP48](#) [MSP430F67791AIPZ](#) [MSP430F67641AIPZR](#) [MSP430F67641AIPN](#) [MSP430F67641IPN](#)
[ADE5169ASTZF62](#) [ADE5569ASTZF62](#) [ADE7166ASTZF16](#) [ADUCM350BBCZ](#) [71M6521FE-IGT/F](#) [71M6541GT-IGTR/F](#) [71M6532F-](#)
[IGT/F](#) [71M6533H-IGT/F](#) [71M6533-IGT/F](#) [71M6534-IGT/F](#) [71M6545-IGT/F](#) [MSP430F67451IPZ](#) [MSP430F6745AIPZ](#)
[MSP430F67641IPZR](#) [MSP430F6778IPZ](#) [MSP430F67791AIPZ](#) [MSP430F67791IPEU](#) [MSP430F67791IPZ](#) [MSP430F6779AIPZ](#)
[MSP430F6779AIPZ](#) [MSP430F6779AIPZ](#) [MSP430F6779AIPZR](#) [MSP430F6779IPZR](#) [MSP430FR6037IPZ](#) [MSP430FR6045IPZ](#)
[MSP430FR60471IPZ](#) [MSP430FR6047IPZ](#) [MSP430FR6047IPZR](#)