

FEATURES

- Implements proposals of SFF-8472 at device address A2h
 [Note: requires use of external EEPROM at address A0h for full compliance.]
- Scalable four-input muxing analog-to-digital converter (ADC)
- Direct-to-digital temperature converter
- Programmable alarm and warning conditions
- Temperature-compensated, programmable three-input muxing fast comparator
- Access temperature, data, and device control through a 2-wire interface
- Operates from 3V or 5V supplies
- Packaging: 25-ball BGA
- Operating temperature: -40°C to +100°C
- Programming temperature: 0°C to +70°C
- Three levels of security
- 127 bytes EEPROM for security level 1
- 128 bytes EEPROM for security level 2
- Address space is GBIC compliant (with use of external EEPROM at device address A0h)

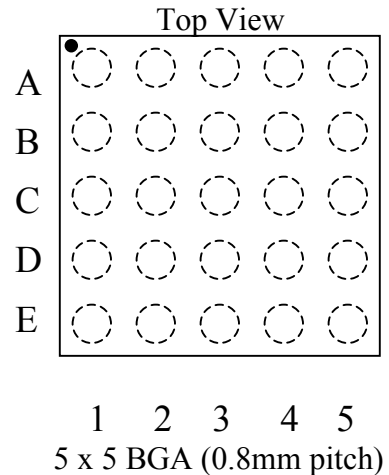

ORDERING INFORMATION

DS1852B-000	25-BALL BGA
DS1852B-000+	25-BALL BGA LF
DS1852B-000+T&R	25-BALL BGA LF T&R
DS1852B-000/T&R	25-BALL BGA T&R

+ Denotes lead-free package.

DESCRIPTION

The DS1852 transceiver monitor manages all system monitoring functions in a fiber optic data transceiver module, in accordance with proposal SFF-8472. Its functions include 2-wire communications with the host system, EEPROM memory for identification, tracking, and calibration, an ADC with four muxing inputs, three fast comparators, and a temperature sensor to monitor an optical transceiver. The DS1852 has programmable alarm and warning flags for all four analog-to-digital (A/D) conversion values (three user analog inputs plus supply voltage) as well as the temperature. These conditions can be used to determine critical parameters inside each module. The three fast comparators have temperature-compensated programmability. The temperature dependencies of the trip points aid in assessing critical conditions.

The DS1852 is offered for sale free of any royalty or licensing fees.

PIN DESCRIPTIONS

<u>Name</u>	<u>Ball Locations</u>	<u>Description</u>
V_{CC}	D2, D4, E3	Power-Supply Terminal. The DS1852 will support supply voltages ranging from +2.7V to +5.5V.
GND	B3, C2, C4, D3	Ground Terminal
SDA	B5	2-Wire Serial Data. The serial data pin is for serial data transfer to and from the DS1852. The pin is open drain and may be wire-OR'ed with other open-drain or open-collector interfaces.
SCL	A5	2-Wire Serial Clock. The serial clock input is used to clock data into the DS1852 on rising edges and clock data out on falling edges.
B_{in}	A3	Analog Input Pin (Bias Value). Input to A/D.
P_{in}	D1	Analog Input Pin (Power Level). Input to A/D.
R_{in}	A2	Analog Input Pin (Received Power). Input to A/D.
ASEL	B2	Address Select Pin. If set to logic 0, the device address is A0h. If set to logic 1, the value in Table 3, byte D0h determines the chip address (factory default is A2h). For SFF-8472 compliance, this pin should be connected high.
D_{in}	C5	Digital Input Pin (TX Disable). Digital input for mirroring in memory map.
RS_{in}	B4	Digital Input Pin (Rate Select). Digital input for mirroring in memory map.
F_{in}	E5	Digital Input Pin (TX Fault). Digital input for mirroring in memory map.
L_{in}	A1	Digital Input Pin (LOS). Digital input for mirroring in memory map.
NC	A4, B1, C1, D5, E1, E2, E4, C3	No Connect

DS1852 BLOCK DIAGRAM Figure 1

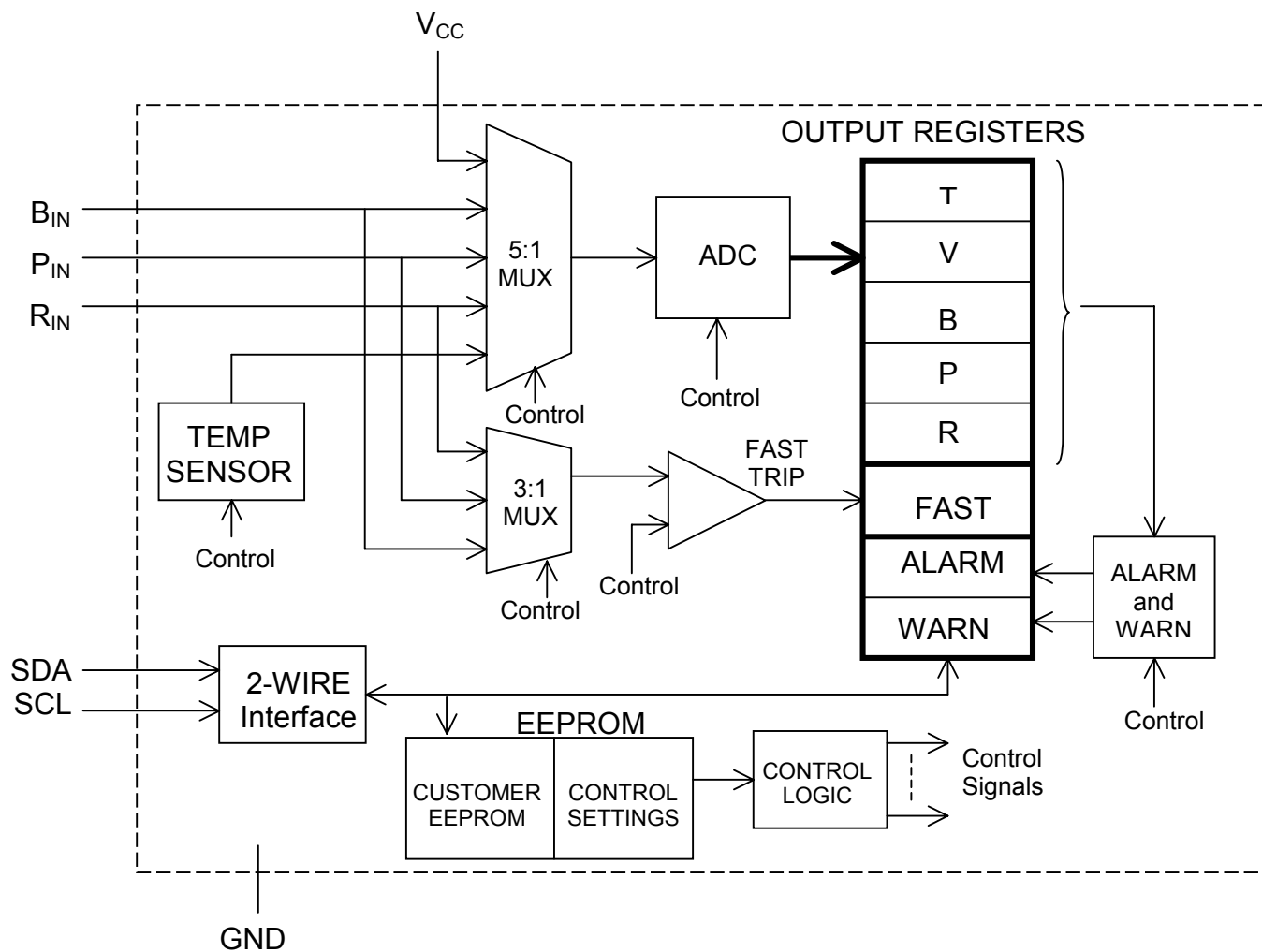

DEVICE OPERATION

Security

To prevent accidental overwrites of key device data, a data lockout feature is incorporated. A 32-bit password provides access to the “manufacturer” memory locations. These locations are in addition to the unprotected “user” memory locations:

- 1) User—This is the default state after power-up; it allows read access to standard IEEE identity table and standard monitoring and status functions.
- 2) Manufacturer Level 1—This allows access to customer data table and some selected setups (password 1).
- 3) Manufacturer Level 2—This allows access to all memory, settings, and features (password 2).

The level 1 password is located in Table 03h EEPROM (bytes D3h to D6h) and may be changed by gaining access through the level 2 password.

The level 2 password is set in protected EEPROM and is programmed during factory test.

During power-up, the 32-bit password entry (addresses 7Bh to 7Eh) is set to all 1s. This is the value that is compared to the level 1 password entry in Table 03h to grant level 1 access. Therefore, the level 1 password should not be set to all 1s or the user will gain level 1 access after each power-on.

By default, both passwords are factory preset to 00h.

To gain access to a security level, a 4-byte password is written into Table 00h, bytes 7Bh to 7Eh. If the written data matches one of the passwords, that corresponding level of access is granted until the password entry is changed or the power is cycled. Entering the level 2 password allows access to both the level 1 data and the level 2 data. The 4-byte password is write-only.

ANALOG-TO-DIGITAL CONVERTER

The ADC reads a total of five inputs: V_{CC} (internal), temperature (internal), and external inputs B_{in} , P_{in} , and R_{in} . All conversions are updated every 13ms (nominal) or 20ms (max) in rotation. The conversions are absolute and compared to an internal reference. While the 16-bit values are read, only the upper 12 are significant. The lower four bits are undefined.

The temperature and analog voltage inputs are calibrated by Dallas Semiconductor and read with the following scale:

Temperature: High byte: -128°C to $+127^{\circ}\text{C}$ signed; low byte: $1/256^{\circ}\text{C}$. The lower four bits should be ignored.

S	2^6	2^5	2^4	2^3	2^2	2^1	2^0
2^{-1}	2^{-2}	2^{-3}	2^{-4}	2^{-5}	2^{-6}	2^{-7}	2^{-8}

V_{CC} : This reads as an unsigned 16-bit quantity at $100\mu\text{V}$ LSB, with a maximum range of 6.5535V , when using the factory default value. The lower four bits should be ignored.

B_{in} , P_{in} , R_{in} : These read as an unsigned 16-bit quantity at $38.147\mu\text{V}$ LSB, with a maximum range of 2.500V , when using factory default values. The lower four bits should be ignored.

2^{15}	2^{14}	2^{13}	2^{12}	2^{11}	2^{10}	2^9	2^8
2^7	2^6	2^5	2^4	2^3	2^2	2^1	2^0

Each analog input has a 16-bit scaling calibration in Table 03h EEPROM. This allows the analog conversion values to be calibrated for full scale at any input voltage from 0.2V to 6.5535V . The ADC conversion value will clamp rather than roll over. Each external analog channel has a maximum input voltage of V_{CC} independent of the calibration factor.

The upper four bits of scaling select the coarse range; the lower 12 bits are for fine adjustments. The algorithm to trim the scale is described below.

The scaling factors for each input (V_{CC} , $V_{B_{in}}$, $V_{P_{in}}$, and $V_{R_{in}}$) are 16 bits wide. They are located in Table 03h at addresses C8h to CFh, respectively. The 16 bits are a combination of two trims. The lower 12 bits are binary weighted and give the high resolution trim for scaling the input to output relationship. The upper four bits are a coarse-adjust of the lower 12 bits. In other words, the upper four bits scale the LSB value of the binary weighted lower 12 bits.

As an illustration, assume a value of 1V is needed to read full scale. Force a voltage less than 1V (975mV , for example) to keep clamping out of the way. The closer to max voltage the better, but not too close.

- 1) Set the scale trim to 0FFFh (the upper four bits to all zeros and the lower 12 bits to all ones).
- 2) Use a SAR approach on the upper four bits, starting with 1000b, to find the smallest 4-bit trim necessary to cause the voltage reading to be above the input (in this case, greater than or equal to 975mV). If they all clamp, that is okay. That means 0000b is the needed value for the upper four

bits. This step has now adjusted the LSB of the lower 12 bits so that the best possible trim is acquired with the lower 12 bits.

If too high a value is used in the four bits, then the resolution of the 12 bits is too high and absolute accuracy is sacrificed. If too low a value is used in the four bits, then the resolution of the 12 bits is too small, so a maximum reading is not possible and a large gain error is present through the entire range.

Example code can be found near the end of this data sheet.

POWER-ON LOGIC

V_{CC} is compared to an internal reference voltage, and if it is below V_{CC} minimum, all internal logic and outputs are held in their reset state. When V_{CC} rises above V_{CC} minimum, the system reset is released.

The DS1852 will not begin monitoring operations until V_{CC} has risen above the analog minimum voltage. However, communication on the 2-wire bus can occur at a V_{CC} level lower than the analog minimum voltage. This allows access to the power-on logic bit located in Table 00h, address 6Eh, bit 0. The analog minimum voltage is less than 2.7V but greater than the digital minimum voltage. Above the analog minimum voltage, the DS1852 will begin to function in a predictable manner but will not satisfy specifications until V_{CC} is above 2.7V.

TEMPERATURE-DEPENDENT FAST ALARM COMPARATORS

The DS1852 has a three-input muxing fast alarm comparator with a response time of less than 10 μ s for each input. This provides a coarse but fast approximation of whether analog inputs B_{in} , P_{in} , and R_{in} are above their temperature-dependent value. Each comparator has an 8-bit max value set in Table 03h, address D8h to E7h. The trip point range is adjustable from 10mV to 2.5V. Each LSB is approximately 10mV. The outputs of these comparators are readable in Table 00h (alarm bytes 1 and 0) and may be overwritten if their corresponding fast alarm override bit is set in Table 03h EEPROM.

The B_{in} alarm can be set to eight unique temperature-dependent trip values, which allows the user to set trip points for different temperature ranges. The P_{in}/R_{in} fast alarms act similarly, but can only be set to four unique temperature-dependent values. For more information, refer to Table 03h.

HIGH-RESOLUTION ALARM COMPARATORS

There are 10 alarm comparators for the five analog channels. There is a 'high alarm' comparator whose output is active if the analog signal is above its threshold and a 'low alarm' comparator whose output is active if the analog signal is below its threshold. These comparators have a 2-byte set point in the same format as the analog converter data in Table 03h. The outputs of these comparators are readable in Table 00h (70h) and may be overwritten if their corresponding alarm override bit is set in Table 03h EEPROM.

WARNING COMPARATORS

The 10 warning comparators function the same way as the alarm comparators, but can be set to trip at different levels. Typically, they would be set to trip prior to the alarm comparators. The set points are in Table 03h and the outputs can be read from Table 00h.

DIGITAL INPUTS

The four digital inputs (D_{in} , RS_{in} , F_{in} , and L_{in}) can be read through the 2-wire bus. The logic levels at these inputs are mirrored in the “logic states” byte (6Eh) in Table 00h.

2-WIRE OPERATION

Clock and Data Transitions

The SDA pin is normally pulled high with an external resistor or device. Data on the SDA pin may only change during SCL low time periods. Data changes during SCL high periods will indicate a start or stop conditions depending on the conditions discussed below. See Figure 2 for further details.

Start Condition

A high-to-low transition of SDA with SCL high is a start condition that must precede any other command. See Figure 2 for further details.

Stop Condition

A low-to-high transition of SDA with SCL high is a stop condition. After a read sequence, the stop command places the DS1852 into a low-power mode. See Figure 2 for further details.

Acknowledge Bit

All address bytes and data bytes are transmitted through a serial protocol. The DS1852 pulls SDA low during the ninth clock pulse to acknowledge that it has received each word.

Standby Mode

The DS1852 features a low-power mode that is automatically enabled after power-on, after a stop command, and after the completion of all internal operations.

2-Wire Interface Reset

After any interruption in protocol, power loss, or system reset, the following steps reset the DS1852:

- 1) Clock up to nine cycles.
- 2) Look for SDA high in each cycle while SCL is high.
- 3) Create a start condition while SDA is high.

Device Addressing

The DS1852 must receive an 8-bit device address word following a start condition to enable a specific device for a read or write operation. The address word is clocked into the DS1852 MSB to LSB. The address word defaults to A0h then the R/W (READ/WRITE) bit when ASEL is a logic zero. If the R/W bit is high, a read operation is initiated. If R/W is low, a write operation is initiated. The device address is changed to the internal chip address (Table 03h address D0h) when ASEL is logic one. The default internal chip address from the factory is A2h.

Write Operations

After receiving a matching address byte with the R/W bit set low, the device goes into the write mode of operation. The master must transmit an 8-bit EEPROM memory address to the device to define the address where the data is to be written. After the byte has been received, the DS1852 will transmit a zero for one clock cycle to acknowledge the receipt of the address. The master must then transmit an 8-bit data word to be written into this address. The DS1852 will again transmit a zero for one clock cycle to acknowledge the receipt of the data. At this point the master must terminate the write operation with a stop condition for the write to be initiated. If a start condition is sent in place of the stop condition, the write is aborted and the data received during that operation is discarded. If the stop condition is received, the DS1852 enters an internally timed write process (t_w) to the EEPROM memory. The DS1852 will not send an acknowledge bit for any 2-wire communication during the EEPROM write process.

The DS1852 is capable of an 8-byte page write. A page is any 8-byte block of memory starting with an address evenly divisible by eight and ending with the starting address plus seven. For example, addresses 00h through 07h constitute one page. Other pages would be addresses 08h through 0Fh, 10h through 17h, 18h through 1Fh, etc.

A page write is initiated the same way as a byte write, but the master does not send a stop condition after the first byte. Instead, after the slave has received the data byte, the master can send up to seven more bytes using the same nine-clock sequence. The master must terminate the write cycle with a stop condition or the data clocked into the DS1852 will not be latched into permanent memory.

The address counter rolls on a page during a write. The counter does not count through the entire address space as during a read. For example, if the starting address is 06h and four bytes are written, the first byte goes into address 06h. The second goes into address 07h. The third goes into address 00h (not 08h). The fourth goes into address 01h. If more than nine or more bytes are written before a stop condition is sent, the first bytes sent are overwritten. Only the last eight bytes of data are written to the page.

Acknowledge Polling

Once the internally timed write has started and the DS1852 inputs are disabled, acknowledge polling can be initiated. The process involves transmitting a start condition followed by the device address. The R/W bit signifies the type of operation that is desired. The read or write sequence will only be allowed to proceed if the internal write cycle has completed and the DS1852 responds with a zero.

Read Operations

After receiving a matching address byte with the R/W bit set high, the device goes into the read mode of operation. There are three read operations: current address read, random read, and sequential address read.

CURRENT ADDRESS READ

The DS1852 has an internal address register that contains the address used during the last read or write operation, incremented by one. This data is maintained as long as V_{CC} is valid. If the most recent address was the last byte in memory, then the register resets to the first address. This address stays valid between operations as long as power is available.

Once the device address is clocked in and acknowledged by the DS1852 with the R/W bit set to high, the current address data word is clocked out. The master does not respond with a zero, but does generate a stop condition afterwards.

RANDOM READ

A random read requires a dummy byte write sequence to load in the data word address. Once the device and data address bytes are clocked in by the master, and acknowledged by the DS1852, the master must generate another start condition. The master now initiates a current address read by sending the device address with the R/W bit set high. The DS1852 will acknowledge the device address and serially clocks out the data byte.

SEQUENTIAL ADDRESS READ

Sequential reads are initiated by either a current address read or a random address read. After the master receives the first data byte, the master responds with an acknowledge. As long as the DS1852 receives this acknowledge after a byte is read, the master may clock out additional data words from the DS1852. After reaching address FFh, it resets to address 00h.

The sequential read operation is terminated when the master initiates a stop condition. The master does not respond with a zero.

For a more detailed description of 2-wire theory of operation, see *2-WIRE SERIAL PORT OPERATION*.

2-WIRE SERIAL PORT OPERATION

The 2-wire serial port interface supports a bidirectional data transmission protocol with device addressing. A device that sends data on the bus is defined as a transmitter, and a device receiving data as a receiver. The device that controls the message is called a “master.” The devices that are controlled by the master are “slaves”. A master device that generates the serial clock (SCL), controls the bus access, and generates the START and STOP conditions must control the bus. The DS1852 operates as a slave on the 2-wire bus. Connections to the bus are made through the open-drain I/O lines SDA and SCL. The following I/O terminals control the 2-wire serial port: SDA, SCL, and ASEL. Timing diagrams for the 2-wire serial port can be found in Figures 2 and 3. Timing information for the 2-wire serial port is provided in the *AC ELECTRICAL CHARACTERISTICS* table for 2-wire serial communications.

The following bus protocol has been defined:

- Data transfer may be initiated only when the bus is not busy.
- During data transfer, the data line must remain stable whenever the clock line is HIGH. Changes in the data line while the clock line is HIGH will be interpreted as control signals.

Accordingly, the following bus conditions have been defined:

Bus not busy: Both data and clock lines remain HIGH.

Start data transfer: A change in the state of the data line from HIGH to LOW while the clock is HIGH defines a START condition.

Stop data transfer: A change in the state of the data line from LOW to HIGH while the clock line is HIGH defines the STOP condition.

Data valid: The state of the data line represents valid data when, after a START condition, the data line is stable for the duration of the HIGH period of the clock signal. The data on the line can be changed during the LOW period of the clock signal. There is one clock pulse per bit of data. Figures 2 and 3 detail how data transfer is accomplished on the 2-wire bus. Depending upon the state of the R/W bit, two types of data transfer are possible.

Each data transfer is initiated with a START condition and terminated with a STOP condition. The number of data bytes transferred between START and STOP conditions is not limited and is determined by the master device. The information is transferred byte-wise and each receiver acknowledges with a ninth bit.

Within the bus specifications a regular mode (100kHz clock rate) and a fast mode (400kHz clock rate) are defined. The DS1852 works in both modes.

Acknowledge: Each receiving device, when addressed, is obliged to generate an ‘acknowledge’ after the byte has been received. The master device must generate an extra clock pulse, which is associated with this acknowledge bit.

A device that acknowledges must pull down the SDA line during the acknowledge clock pulse in such a way that the SDA line is a stable LOW during the HIGH period of the acknowledge-related clock pulse. Of course, setup and hold times must be taken into account. A master must signal an end of data to the slave by not generating an acknowledge bit on the last byte that has been clocked out of the slave. In this case, the slave must leave the data line HIGH to enable the master to generate the STOP condition.

- 1) Data transfer from a master transmitter to a slave receiver. The first byte transmitted by the master is the command/control byte. Next follows a number of data bytes. The slave returns an acknowledge bit after each received byte.
- 2) Data transfer from a slave transmitter to a master receiver. The master transmits the first byte (the command/control byte) to the slave. The slave then returns an acknowledge bit. Next follows a number of data bytes transmitted by the slave to the master. The master returns an acknowledge bit after all received bytes other than the last byte. At the end of the last received byte, a 'not acknowledge' can be returned.

The master device generates all serial clock pulses and the START and STOP conditions. A transfer is ended with a STOP condition or with a repeated START condition. Since a repeated START condition is also the beginning of the next serial transfer, the bus will not be released.

The DS1852 may operate in the following two modes:

- 1) Slave receiver mode: Serial data and clock are received through SDA and SCL, respectively. After each byte is received, an acknowledge bit is transmitted. START and STOP conditions are recognized as the beginning and end of a serial transfer. Address recognition is performed by hardware after reception of the slave (device) address and direction bit.
- 2) Slave transmitter mode: The first byte is received and handled as in the slave receiver mode. However, in this mode the direction bit will indicate that the transfer direction is reversed. Serial data is transmitted on SDA by the DS1852 while the serial clock is input on SCL. START and STOP conditions are recognized as the beginning and end of a serial transfer.

Slave Address: Command/control byte is the first byte received following the START condition from the master device. The command/control byte consists of a 4-bit control code. For the DS1852, this is set as *1010 000* (when ASEL is '0') binary for R/W operations. The last bit of the command/control byte (R/W) defines the operation to be performed. When set to a 1 a read operation is selected, and when set to a 0 a write operation is selected.

Following the START condition, the DS1852 monitors the SDA bus checking the device type identifier being transmitted. Upon receiving the chip address control code, and the R/W bit, the slave device outputs an acknowledge signal on the SDA line.

2-WIRE DATA TRANSFER PROTOCOL Figure 2

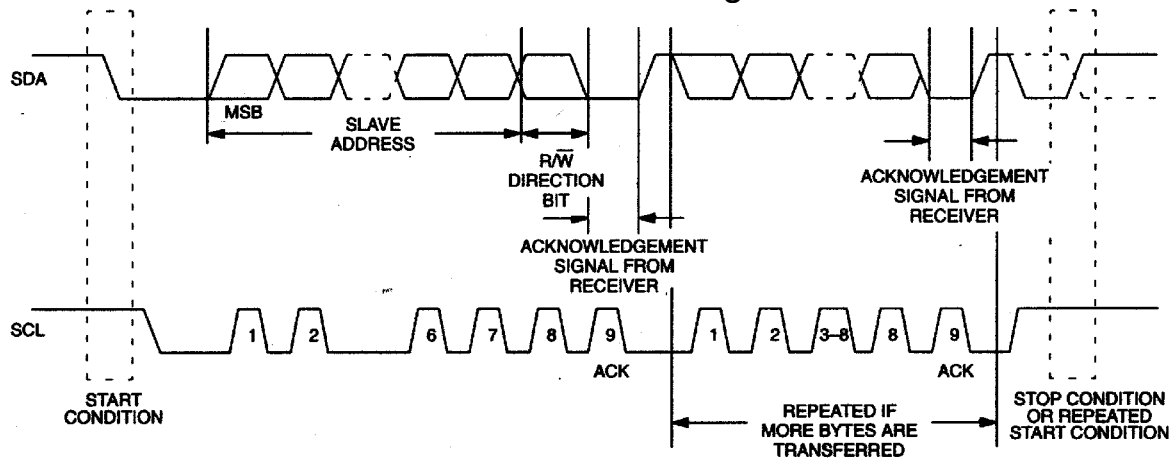

2-WIRE AC CHARACTERISTICS Figure 3

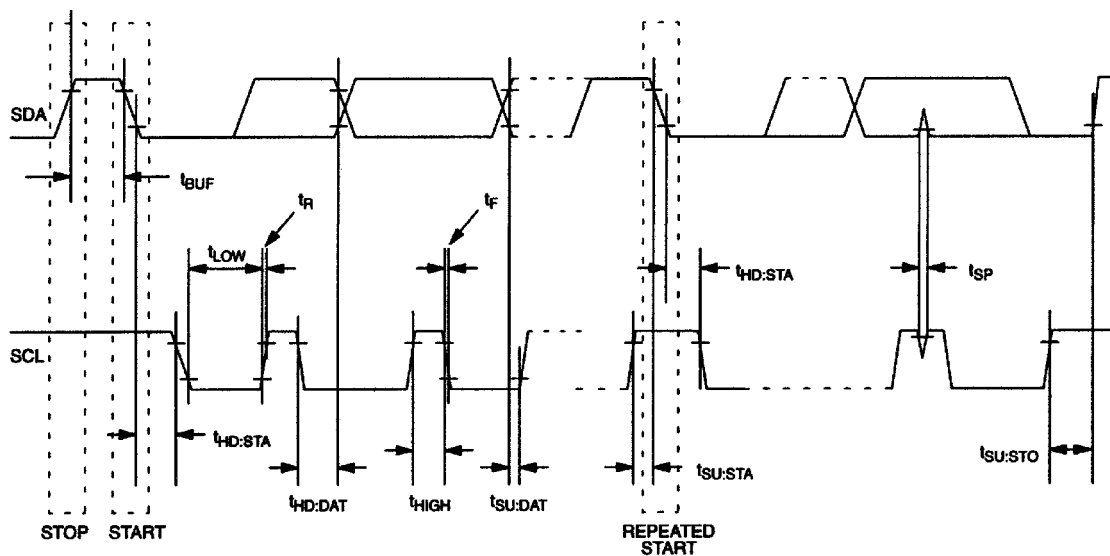

MEMORY MAP

Memory access to the DS1852 is through the 2-wire interface. See the *2-WIRE OPERATION* section.

The memory within the DS1852 is organized into multiple tables. The lower 128 bytes of memory are common to all tables, the upper 128 bytes are addressed according to the table select byte at 7Fh. Valid values of the table address byte are 00h to 03h, to access Tables 00h through 03h.

00h Tables 00h – 03h Lower 128 bytes R- All W - Level 2* 7Fh			
80h Table 00h Upper 128 Bytes No Physical Memory FF	80h Table 01h Upper 128 Bytes R/W - Level 1 FF	80h Table 02h Upper 128 Bytes R/W - Level 2 FF	80h Table 03h Upper 128 Bytes R/W - Level 2 FF

*For permission details of this memory block refer to following table.

The following tables detail the memory contents. Where descriptions are underlined an expanded table indicates the function of individual bits within the byte. The reserved memory locations should not be used even though R/W access may be possible.

Not all memory is EEPROM; RAM cells are shaded within the tables, and denoted beneath.

Table 00h-FFh (Lower)								
Address	Byte 0	Byte 1	Byte 2	Byte 3	Byte 4	Byte 5	Byte 6	Byte 7
	bits<7-0>	bits<7-0>	bits<7-0>	bits<7-0>	bits<7-0>	bits<7-0>	bits<7-0>	bits<7-0>
00h	IEEE Data EEPROM (Read Access – All, Write Access – Level 2)							
...								
...								
58h								
60h	Temp MSB	Temp LSB	V _{cc} MSB	V _{cc} LSB	B _{in} MSB	B _{in} LSB	P _{in} MSB	P _{in} LSB
68h	R _{in} MSB	R _{in} LSB	<i>reserved</i>	<i>reserved</i>	<i>reserved</i>	<i>reserved</i>	I/O states	AD updated
70h	<u>Alarm flag3</u>	<u>alarm flag2</u>	<u>alarm flag1</u>	<u>alarm flag0</u>	<u>warn flag3</u>	<u>warn flag2</u>	<u>warn flag1</u>	<u>warn flag0</u>
78h	<i>Reserved</i>	<i>reserved</i>	<i>reserved</i>	PWE Byte 3	PWE Byte 2	PWE Byte 1	PWE Byte 0	table select

Bytes 60h through 7Fh are RAM, see expanded table for access requirements.

Table 00h-FFh (Lower) Expanded								
Byte Name	Bit 7	Bit 6	Bit 5	Bit 4	Bit 3	Bit 2	Bit 1	Bit 0
I/O states (1)	D _{in}	<i>reserved</i>	<i>reserved</i>	RS _{in}	<i>reserved</i>	F _{in}	L _{in}	power-on logic
AD updated (2)	T-updated	V-updated	B-updated	P-updated	R-updated	<i>reserved</i>	<i>reserved</i>	<i>reserved</i>
alarm flag3 (3)	T-ad hi	T-ad lo	V-ad hi	V-ad lo	B-ad hi	B-ad lo	P-ad hi	P-ad lo
alarm flag2 (3)	R-ad hi	R-ad lo	<i>reserved</i>	<i>reserved</i>	<i>reserved</i>	<i>reserved</i>	<i>reserved</i>	<i>reserved</i>
alarm flag1 (3)	<i>reserved</i>	<i>reserved</i>	<i>reserved</i>	<i>reserved</i>	B-ft hi	<i>reserved</i>	P-ft hi	<i>reserved</i>
alarm flag0 (3)	R-ft hi	<i>reserved</i>	<i>reserved</i>	<i>reserved</i>	<i>reserved</i>	<i>reserved</i>	<i>reserved</i>	<i>reserved</i>
warn flag3 (3)	T-ad hi	T-ad lo	V-ad hi	V-ad lo	B-ad hi	B-ad lo	P-ad hi	P-ad lo
warn flag2 (3)	R-ad hi	R-ad lo	<i>reserved</i>	<i>reserved</i>	<i>reserved</i>	<i>reserved</i>	<i>reserved</i>	<i>reserved</i>
warn flag1 (3)	<i>reserved</i>	<i>reserved</i>	<i>reserved</i>	<i>reserved</i>	<i>reserved</i>	<i>reserved</i>	<i>reserved</i>	<i>reserved</i>
warn flag0 (3)	<i>reserved</i>	<i>reserved</i>	<i>reserved</i>	<i>reserved</i>	<i>reserved</i>	<i>reserved</i>	<i>reserved</i>	<i>reserved</i>

- (1) Read Access – All, Write Access – None
- (2) Read Access – All, Write Access – All (The DS1852 will also write to this byte)
- (3) Read Access – All, Write Access – Level 2 + config bit (Table 03h, E8h)

Table 00h (Lower)

Memory Location (Table 00h, Lower)	Name of Location	Function
00h – 5Fh	IEEE Data	This memory block is used to store required GBIC data.
60h	Temperature MSB	This byte contains the MSB of the 15-bit 2's complement temperature output from the temperature sensor.
61h	Temperature LSB	This byte contains the LSB of the 15-bit 2's complement temperature output from the temperature sensor.
62h – 63h	V _{cc} Value	These bytes contain the MSB (62h) and the LSB (63h) of the measured V _{CC} .
64h – 65h	B _{in} Value	These bytes contain the MSB (64h) and the LSB (65h) of the measured B _{in} .
66h – 67h	P _{in} Value	These bytes contain the MSB (66h) and the LSB (67h) of the measured P _{in} .
68h – 69h	R _{in} Value	These bytes contain the MSB (68h) and the LSB (69h) of the measured R _{in} .
6Eh	IO States	Bit 0 will be 0 when the analog monitoring is active.
6Fh	A/D Updated	Allows the user to verify if an update from the A/D has occurred to the five values: temperature, V _{CC} , B _{in} , P _{in} and R _{in} . The user writes the byte to 00h. Once a conversion is complete for a given value, its bit will change to '1'.
70h – 73h	Alarm Flags	These bits reflect the state of the alarms as a conversion updates. High alarm bits are '1' if converted value is greater than corresponding high limit. Low alarm bits are '1' if converted value is less than corresponding low limit. Otherwise, bits are '0'.
74h – 77h	Warning Flags	These bits reflect the state of the warnings as a conversion updates. High warning bits are '1' if converted value is greater than corresponding high limit. Low warning bits are '1' if converted value is less than corresponding low limit. Otherwise, bits are '0'.
7Bh – 7Eh	Password Entry Bytes PWE Byte 3 (7Bh) MSByte PWE Byte 2 (7Ch) PWE Byte 1 (7Dh) PWE Byte 0 (7Eh) LSByte	The four bytes are used for password entry. The entered password will determine the user's R/W privileges. During power-up these bits are set to all 1s.
7Fh	Table Select Byte	This byte determines which of the upper memory pages are selected. 00h — No physical memory 01h — Manufacturer EEPROM 02h — Manufacturer EEPROM 03h — Device settings

Table 00h (Upper)								
Address	Byte 0	Byte 1	Byte 2	Byte 3	Byte 4	Byte 5	Byte 6	Byte 7
	bits<7-0>	bits<7-0>	bits<7-0>	bits<7-0>	bits<7-0>	bits<7-0>	bits<7-0>	bits<7-0>
80h	Reserved by IEEE (no physical memory)							
...								
...								
F8h								

Table 01h (Upper)								
Address	Byte 0	Byte 1	Byte 2	Byte 3	Byte 4	Byte 5	Byte 6	Byte 7
	bits<7-0>	bits<7-0>	bits<7-0>	bits<7-0>	bits<7-0>	bits<7-0>	bits<7-0>	bits<7-0>
80h	Manufacturer EEPROM (Read Access – Level 1, Write Access – Level 1)							
...								
...								
F0h								
F8h								<i>reserved</i>

Address FFh is RAM

Table 02h (Upper)								
Address	Byte 0	Byte 1	Byte 2	Byte 3	Byte 4	Byte 5	Byte 6	Byte 7
	bits<7-0>	bits<7-0>	bits<7-0>	bits<7-0>	bits<7-0>	bits<7-0>	bits<7-0>	bits<7-0>
80h	Manufacturer EEPROM (Read Access – Level 2, Write Access – Level 2)							
...								
...								
F8h								

Table 03h (Upper)								
Address	Byte 0	Byte 1	Byte 2	Byte 3	Byte 4	Byte 5	Byte 6	Byte 7
	bits<7-0>	bits<7-0>	bits<7-0>	bits<7-0>	bits<7-0>	bits<7-0>	bits<7-0>	bits<7-0>
	HI ALARM		LO ALARM		HI WARN		LO WARN	
80h	T alarm MSB	T alarm LSB	T alarm MSB	T alarm LSB	T warn MSB	T warn LSB	T warn MSB	T warn LSB
88h	V alarm MSB	V alarm LSB	V alarm MSB	V alarm LSB	V warn MSB	V warn LSB	V warn MSB	V warn LSB
90h	B alarm MSB	B alarm LSB	B alarm MSB	B alarm LSB	B warn MSB	B warn LSB	B warn MSB	B warn LSB
98h	P alarm MSB	P alarm LSB	P alarm MSB	P alarm LSB	P warn MSB	P warn LSB	P warn MSB	P warn LSB
A0h	R alarm MSB	R alarm LSB	R alarm MSB	R alarm LSB	R warn MSB	R warn LSB	R warn MSB	R warn LSB
A8h	<i>reserved</i>	<i>reserved</i>	<i>reserved</i>	<i>reserved</i>	<i>reserved</i>	<i>reserved</i>	<i>reserved</i>	<i>reserved</i>
B0h	<i>reserved</i>	<i>reserved</i>	<i>reserved</i>	<i>reserved</i>	<i>reserved</i>	<i>reserved</i>	<i>reserved</i>	<i>reserved</i>
B8h	<i>reserved</i>	<i>reserved</i>	<i>reserved</i>	<i>reserved</i>	<i>reserved</i>	<i>reserved</i>	<i>reserved</i>	<i>reserved</i>
C0h	<i>reserved</i>	<i>reserved</i>	<i>reserved</i>	<i>reserved</i>	<i>reserved</i>	<i>reserved</i>	<i>reserved</i>	<i>reserved</i>
C8h	V-ad scale MSB	V-ad scale LSB	B-ad scale MSB	B-ad scale LSB	P-ad scale MSB	P-ad scale LSB	R-ad scale MSB	R-ad scale LSB
D0h	<u>chip address</u>	<i>reserved</i>	<i>reserved</i>	PW1 Byte 3	PW1 Byte 2	PW1 Byte 1	PW1 Byte 0	<i>reserved</i>
D8h	<u>B Fast trip0</u>	<u>B Fast trip1</u>	<u>B Fast trip2</u>	<u>B Fast trip3</u>	<u>B Fast trip4</u>	<u>B Fast trip5</u>	<u>B Fast trip6</u>	<u>B Fast trip7</u>
E0h	<u>P Fast trip0</u>	<u>P Fast trip1</u>	<u>P Fast trip2</u>	<u>P Fast trip3</u>	<u>R Fast trip0</u>	<u>R Fast trip1</u>	<u>R Fast trip2</u>	<u>R Fast trip3</u>
E8h	<u>config/o-ride</u>	<i>reserved</i>	<i>reserved</i>	<i>reserved</i>	<i>reserved</i>	<i>reserved</i>	<i>reserved</i>	<i>reserved</i>
F0h	<i>reserved</i>	<i>reserved</i>	<i>reserved</i>	<i>reserved</i>	<i>reserved</i>	<i>reserved</i>	<i>reserved</i>	<i>reserved</i>
F8h	<i>reserved</i>	<i>reserved</i>	<i>reserved</i>	<i>reserved</i>	<i>reserved</i>	<i>reserved</i>	<i>reserved</i>	<i>reserved</i>

Address E8h is RAM.

Read Access – Level 2, Write Access – Level 2

Fast-Trip Temperature Relationships								
Fast Trip	Byte 0	Byte 1	Byte 2	Byte 3	Byte 4	Byte 5	Byte 6	Byte 7
	bits<7-0>	bits<7-0>	bits<7-0>	bits<7-0>	bits<7-0>	bits<7-0>	bits<7-0>	bits<7-0>
* B-in	< -8	[-8 to 8)	[8 to 24)	[24 to 40)	[40 to 56)	[56 to 72)	[72 to 88)	≥ 88
* P-in	< 8	[8 to 40)	[40 to 72)	≥ 72				
* R-in	< 8	[8 to 40)	[40 to 72)	≥ 72				

* There is one degree of hysteresis at transitions only (e.g., for B-in, if temp increases to +8.0°C then byte 2 is active. It will remain active until temp reaches +24.0°C or falls below +7.0°C.).

Table 03h (Expanded)								
Byte Name	Bit 7	Bit 6	Bit 5	Bit 4	Bit 3	Bit 2	Bit 1	Bit 0
Chip address	b ⁷	b ⁶	b ⁵	b ⁴	b ³	b ²	b ¹	X
X-ad scale MSB*	2 ¹⁵	2 ¹⁴	2 ¹³	2 ¹²	2 ¹¹	2 ¹⁰	2 ⁹	2 ⁸
X-ad scale LSB*	2 ⁷	2 ⁶	2 ⁵	2 ⁴	2 ³	2 ²	2 ¹	2 ⁰
config/O-ride	<i>reserved</i>	<i>reserved</i>	manual AD alarm	EE Bar	SW-POR	A/D Enable	Manual fast alarm	<i>reserved</i>

* V-, B-, P- or R- as appropriate

Table 03h		
Memory Location (Table 3)	Name of Location	Function of Location
80h – 81h 88h – 89h 90h – 91h 98h – 99h A0h – A1h	Temperature High Alarm V _{CC} High Alarm B _{in} High Alarm P _{in} High Alarm R _{in} High Alarm	The value written to this location serves as the high alarm limit. Data format is the same as the corresponding value (temperature, V _{CC} , B _{in} , P _{in} , R _{in}).
82h – 83h 8Ah – 8Bh 92h – 93h 9Ah – 9Bh A2h – A3h	Temperature Low Alarm V _{CC} Low Alarm B _{in} Low Alarm P _{in} Low Alarm R _{in} Low Alarm	The value written to this location serves as the low alarm limit. Data format is the same as the corresponding value (temperature, V _{CC} , B _{in} , P _{in} , R _{in}).
84h – 85h 8Ch – 8Dh 94h – 95h 9Ch – 9Dh A4h – A5h	Temp High Warning V _{CC} High Warning B _{in} High Warning P _{in} High Warning R _{in} High Warning	The value written to this location serves as the high warning limit. Data format is the same as the corresponding value (temperature, V _{CC} , B _{in} , P _{in} , R _{in}).
86h – 87h 8Eh – 8Fh 96h – 97h 9Eh – 9Fh A6h – A7h	Temperature Low Warning V _{CC} Low Warning B _{in} Low Warning P _{in} Low Warning R _{in} Low Warning	The value written to this location serves as the low warning limit. Data format is the same as the corresponding value (temperature, V _{CC} , B _{in} , P _{in} , R _{in}).
B2h, Bah, C5h – C7h	Logic State Control	These should be left at the factory default values as shown in the table to allow reading of the digital inputs from address 6Eh in Table 00h.
C8h – C9h CAh – CBh CCh – CDh CEh - CFh	V _{CC} – A/D Scale B _{in} – A/D Scale P _{in} – A/D Scale R _{in} – A/D Scale	16 bits of gain adjustment for corresponding A/D conversion values.
D0h	Chip Address	This is the chip address used when pin ASEL is high (A2h default).
D3h – D6h	PW1 Byte 3 (D3h) MSB PW1 Byte 2 (D4h) PW1 Byte 1 (D5h) PW1 Byte 0 (D6h) LSB	The four bytes are used for password 1 entry. The password entered here will allow Level 1 access. Factory default is 00h.
D8h – DFh	B _{in} Fast Trip	These bytes define the fast-trip comparison over temperature.
E0h – E3h	P _{in} Fast Trip	These bytes define the fast-trip comparison over temperature.
E4h – E7h	R _{in} Fast Trip	These bytes define the fast-trip comparison over temperature.
E8h	Configuration Override Byte	Location of the bits is defined in Table 03h expanded.

ABSOLUTE MAXIMUM RATINGS*

Voltage on Any Pin Relative to Ground	-0.3V to +6.0V
Operating Temperature Range	-40°C to +125°C
Programming Temperature Range	0°C to +70°C
Storage Temperature Range	-55°C to +125°C
Soldering Temperature	See J-STD-020A specification

**This is a stress rating only and functional operation of the device at these or any other conditions above those indicated in the operation sections of this specification is not implied. Exposure to absolute maximum rating conditions for extended periods of time may affect reliability.*

RECOMMENDED DC OPERATING CONDITIONS (-40°C to +100°C)

PARAMETER	SYMBOL	MIN	TYP	MAX	UNITS	NOTES
Supply Voltage	V _{CC}	+2.7		+5.5	V	1

DC ELECTRICAL CHARACTERISTICS (-40°C to +100°C; V_{CC} = 2.7V to 5.5V)

PARAMETER	SYMBOL	CONDITIONS	MIN	TYP	MAX	UNITS	NOTES
Supply Current	I _{CC}				1.0	mA	4
Digital Power-On RESET	V _{pod}				2.0	V	
Analog Power-On RESET	V _{poa}		2.0		2.5	V	
Input Leakage (SDA, SCL)	I _{IL}		-1		+1	μA	12
Input Logic 1 (SDA, SCL, ASEL)	V _{IH}		0.7V _{CC}		V _{CC} + 0.3	V	
Input Logic 0 (SDA, SCL, ASEL)	V _{IL}		GND - 0.3		0.3 V _{CC}	V	
Input Logic 1 (RS _{in} , D _{in} , F _{in} , L _{in})	V _{IH}		1.5		V _{CC} + 0.3	V	
Input Logic 0 (RS _{in} , D _{in} , F _{in} , L _{in})	V _{IL}		GND - 0.3		0.9	V	
Low Level Output Current (SDA)	I _{OL1}	0.4V	3			mA	
	I _{OL2}	0.6V	6			mA	
I/O Capacitance	C _{I/O}				10	pF	
Input Resistance (RS _{in} , D _{in} , F _{in} , L _{in})	R _{ipu}	to V _{CC}	25	40	55	kΩ	
Input Resistance (ASEL)	R _{ipd}	to GND	25	40	55	kΩ	

A/D CONVERTERS(-40°C to +100°C; $V_{CC} = 2.7V$ to 5.5V)

PARAMETER	SYMBOL	CONDITIONS	MIN	MAX	UNITS	NOTES
Thermometer Error	T_{ERR}	-40°C to +100°C		± 3.0	°C	
Conversion Time	t_{CONVT}	12-bit conversion	10	20	ms	
Voltage A/D input	V_{ADin}		0.0	$V_{CC} + 0.3$	V	
Voltage A/D Offset	V_{ADoff}			± 0.25	% FSR	
Absolute Voltage A/D Error	V_{ADerr}			± 0.5	% FSR	3
Differential Voltage A/D Nonlinearity	$V_{AD_{DNL}}$			± 0.25	% FSR	

COMPARATORS(-40°C to +100°C; $V_{CC} = 2.7V$ to 5.5V)

PARAMETER	SYMBOL	CONDITIONS	MIN	MAX	UNITS	NOTES
Sample Time	t_{smp}		8	10	μs	2
Fast-Trip Input Range	FT_{range}		0	$V_{CC} + 0.3$	V	
Fast-Trip Absolute Error	FT_{err}			±1.0	% FSR	
Fast-Trip Nonlinearity	FT_{DNL}			±2.0	LSB	

AC ELECTRICAL CHARACTERISTICS (-40°C to +100°C, V_{CC} = 2.7V to 5.5V)

PARAMETER	SYMBOL	CONDITIONS	MIN	TYP	MAX	UNITS	NOTES
SCL Clock Frequency	f _{SCL}	Fast Mode Standard Mode	0 0		400 100	kHz	7
Bus Free Time Between STOP and START Condition	t _{BUF}	Fast Mode Standard Mode	1.3 4.7			μs	7
Hold Time (Repeated) START Condition	t _{HD:STA}	Fast Mode Standard Mode	0.6 4.0			μs	7, 8
Low Period of SCL Clock	t _{LOW}	Fast Mode Standard Mode	1.3 4.7			μs	7
High Period of SCL Clock	t _{HIGH}	Fast Mode Standard Mode	0.6 4.0			μs	7
Data Hold Time	t _{HD:DAT}	Fast Mode Standard Mode	0 0		0.9	μs	7, 9, 10
Data Setup Time	t _{SU:DAT}	Fast Mode Standard Mode	100 250			ns	7
Start Setup Time	t _{SU:STA}	Fast Mode Standard Mode	0.6 4.7			μs	7
Rise Time of Both SDA and SCL Signals	t _R	Fast Mode Standard Mode	20+0.1C _B		300 1000	ns	11
Fall Time of Both SDA and SCL Signals	t _F	Fast Mode Standard Mode	20+0.1C _B		300 300	ns	11
Setup Time for STOP Condition	t _{SU:STO}	Fast Mode Standard Mode	0.6 4.0			μs	
Capacitive Load for Each Bus Line	C _B				400	pF	11
Startup Time	t _{ST}				2	ms	5
V _{CC} Power-Up Rate			1			V/s	
EEPROM Write Time	t _w			10	20	ms	6

NONVOLATILE MEMORY CHARACTERISTICS

PARAMETER	SYMBOL	CONDITIONS	MIN	TYP	MAX	UNITS	NOTES
Writes		+85°C	50,000				

NOTES

- 1) All voltages are referenced to ground.
- 2) This is the time for one comparison. The complete cycle is this value multiplied by 3.
- 3) Absolute voltage error for B_{in} , P_{in} , and R_{in} are valid from 0% to 98%.
- 4) $A_{SEL} = GND$, $SDA = SCL = D_{in} = F_{in} = L_{in} = RS_{in} = V_{CC}$.
- 5) The time to begin monitoring operations after V_{CC} has risen above the analog minimum voltage.
- 6) After STOP command has been received. No acknowledges will be issued during this interval.
- 7) A fast mode device can be used in a standard mode system, but the requirement $t_{SU:DAT} > 250ns$ must then be met. This will automatically be the case if the device does not stretch the low period of the SCL signal. If such a device does stretch the low period of the SCL signal, it must output the next data bit to the SDA line $t_{RMAX} + t_{SU:DAT} = 1000 + 250 = 1250ns$ before the SCL line is released.
- 8) After this period, the first clock pulse is generated.
- 9) The maximum $t_{HD:DAT}$ has only to be met if the device does not stretch the low period (t_{LOW}) of the SCL signal.
- 10) A device must internally provide a hold time of at least 300ns for the SDA signal (see the $V_{IH MIN}$ of the SCL signal) in order to bridge the undefined region of the falling edge of SCL.
- 11) C_B — total capacitance of one bus line in picofarads, timing referenced to $0.9V_{CC}$ and $0.1V_{CC}$.
- 12) Input levels equal either V_{CC} or GND.

SCALING THE ADC

```

procedure writeTrimValue(trim :integer); (* write trim to part *)
procedure forceReference(Vin: real); (* applies reference voltage to input pin*)
procedure waitForNewConversion(); (* writes update byte to zero and waits for
of new conversion with present trim *)
function readValue():integer; (* reads converted digital answer *)
procedure ProgramTrim(trim :integer);(*enables EE for table3 & programs trim*)

```

update

Procedure calVad(maxInput :real)

var

```

    Bit           :integer; (* counter - represents binary bit 15-0*)
    trim          :integer; (* present trim values *)
    lsb           :real; (* the lsb value of the voltage reading *)
    Vin           :real; (* the reference input voltage *)
    Dec_in       :integer; (* decimal representation of voltage input *)
    Dec_out      :integer; (* voltage reading in decimal *)
    delta        :integer; (* present error of voltage reading *)
    bestDelta    :integer; (* the error closest to zero *)
    bestTrim     :integer; (* the trim that gave the best delta *)

```

Begin

```

    bestDelta := 1000000;
    bestTrim := 0;
    trim := 4095; (* 0FFFh *)

```

```

    lsb := maxInput / 65535;

```

```

    Dec_in := 63888; (* input is ~97.5% of full scale *)

```

```

    Vin := lsb * Dec_in;

```

```

    forceReference(Vin);

```

```

(*Use SAR approach to trim course adjust on VAD scale bits 15-12*)
for Bit := 15 downto 11 do (* must go 1 bit too far so that zero is
possible solution *)

```

```

    begin
        if (Bit > 11) then
            begin
                trim := trim + lshft(1, Bit);
            end;
        end;

```

```

        writeTrimValue(trim);

```

```

        waitForNewConversion;

```

```

        Dec_out := readVoltage;

```

```

        delta := Dec_out - Dec_in;

```

```

        if ( delta >= 0 ) then

```



```

begin
    bestTrim := trim;

    if (Bit > 11) then
        Begin
            trim := trim - lshft(1,trimBit);
        end;
    end;
end;
end;

```

(* The upper 4 bits of bestTrim contains the answer for the course adjustment.*)

(* It is the smallest value that allows full scale trim with the lower 12 bits*)

(* zero out the lower 12 bits of bestTrim *)

```
trim := land(bestTrim,61440(*F000h*)); (*land() is logical AND function*)
```

(*Use SAR approach to trim resolution on VAD scale bits 11-0*)

```
for Bit := 11 downto -1 do (* must go 1 bit too far so that zero is
possible solution *)
```

```
begin
    if (Bit > 0) then
        begin
            trim := trim + lshft(1,Bit);
        end;

        writeTrimValue(trim);

        waitForNewConversion;

        Dec_out := readVoltage;

        delta := Dec_out - Dec_in;

        if ( abs(delta) <= abs(bestDelta) ) then
            begin
                bestTrim := trim;
                bestDelta := delta;
            end;

            if ( delta > 0 ) then
                begin
                    if (Bit > 0) then
                        Begin
                            trim := trim - lshft(1,trimBit);
                        end;
                end;
            end;
        end;
end;
end;

```

(* bestTrim now contains the trim that gives the lowest delta*)

```
ProgramTrim(bestTrim);
```

```
end;
```

MECHANICAL DRAWING

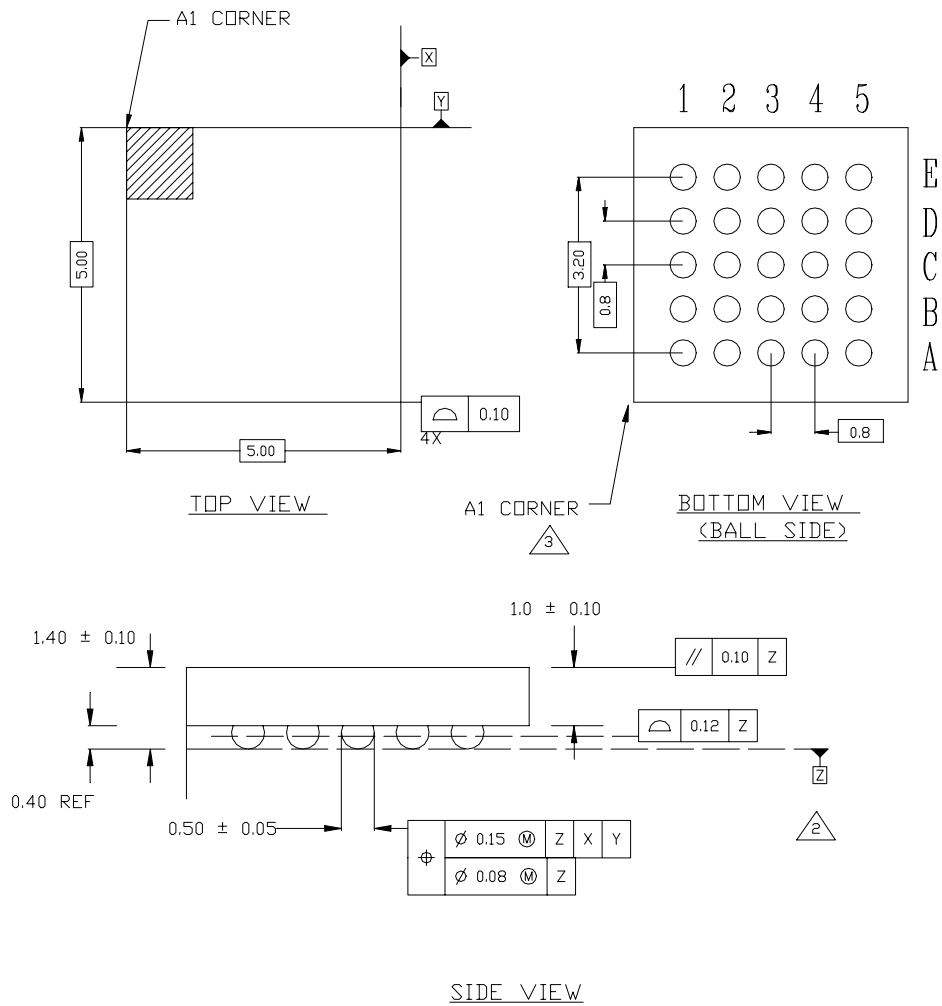

NOTES:

1. DIMENSION IS MM.

2 DATUM Z AND SEATING PLANE ARE DEFINED BY THE SPHERICAL CROWNS OF THE SOLDER BALLS.

3 A1 CORNER OF THE SUBSTRATE MUST BE IDENTIFIED BY METALLIZED MARKINGS.

4 COMPLIANT TO JEDEC OUTLINE MD-205, NO EXACT VARIATION

X-ON Electronics

Largest Supplier of Electrical and Electronic Components

Click to view similar products for [Data Acquisition ADCs/DACs - Specialised category](#):

Click to view products by [Maxim manufacturer](#):

Other Similar products are found below :

[ADE7913ARIZ-RL](#) [LDC2112PWR](#) [LDC2112YFDT](#) [NTE890](#) [NTE995M](#) [CAT5251WI-00-T1](#) [CAT5261WI-00T-QJ](#) [LDC1614RGHR](#)
[AD7869JNZ](#) [ADS7869IPZTR](#) [AMC1306E25DWVR](#) [ADC-24](#) [AS6500-FQFM](#) [AD7616BSTZ](#) [1B21AN](#) [5962-89629013X](#) [5962-8962902LX](#)
[AD2S1200YSTZ](#) [AD2S80AAD](#) [AD2S80ABD](#) [AD2S80AJD](#) [AD2S80AKD](#) [AD2S80ALD](#) [AD2S80ASD](#) [AD2S80ASD/883B](#) [AD2S80ATD](#)
[AD2S80ATE](#) [AD2S80AUD](#) [AD2S82AHPZ](#) [AD2S82AJPZ](#) [AD2S82AKPZ](#) [AD2S82ALP](#) [AD2S90APZ](#) [AD5930YRUZ](#) [AD536AJD](#)
[AD536ASH](#) [AD9834BRUZ-REEL](#) [AD71056ARZ](#) [AD71056ARZ-RL](#) [AD7147PACPZ-500R7](#) [AD7150BRMZ](#) [AD7151BRMZ](#)
[AD7156BCPZ-REEL](#) [AD7156BCPZ-REEL7](#) [AD7569BNZ](#) [AD7569BQ](#) [AD7569BRZ](#) [AD7569JNZ](#) [AD7569JPZ](#) [AD7569JRZ](#)