

ABRIDGED DATA SHEET

DS28E15

DeepCover Secure Authenticator with 1-Wire SHA-256 and 512-Bit User EEPROM

General Description

DeepCover™ embedded security solutions cloak sensitive data under multiple layers of advanced physical security to provide the most secure key storage possible.

The DeepCover Secure Authenticator (DS28E15) combines crypto-strong bidirectional secure challenge-and-response authentication functionality with an implementation based on the FIPS 180-3-specified Secure Hash Algorithm (SHA-256). A 512-bit user-programmable EEPROM array provides nonvolatile storage of application data. Additional protected memory holds a read-protected secret for SHA-256 operations and settings for memory protection control. Each device has its own guaranteed unique 64-bit ROM identification number (ROM ID) that is factory programmed into the chip. This unique ROM ID is used as a fundamental input parameter for cryptographic operations and also serves as an electronic serial number within the application. A bidirectional security model enables two-way authentication between a host system and slave-embedded DS28E15. Slave-to-host authentication is used by a host system to securely validate that an attached or embedded DS28E15 is authentic. Host-to-slave authentication is used to protect DS28E15 user memory from being modified by an unauthentic host. The DS28E15 communicates over the single-contact 1-Wire® bus at overdrive speed. The communication follows the 1-Wire protocol with the ROM ID acting as node address in the case of a multi-device 1-Wire network.

Applications

- Authentication of Consumables
- Secure Feature Control

Ordering Information appears at end of data sheet.

Benefits and Features

- 512-Bit EEPROM with SHA-256 Authentication for Reads and Writes
 - Symmetric-Key-Based Bidirectional Secure Authentication Model Based on SHA-256
 - Strong Authentication with a High-Bit-Count User Programmable Secret and Input Challenge
 - 512 Bits of User EEPROM Partitioned Into Two Pages of 256 Bits
 - User-Programmable and Irreversible EEPROM Protection Modes Including Authentication, Write and Read Protect, and OTP/EEPROM Emulation
 - Unique Factory-Programmed, 64-Bit Identification Number
- Minimalist 1-Wire Interface Lowers Cost and Interface Complexity
 - Reduces Control, Address, Data, Power, and Programming Signals to a Single Data Pin
 - ±8kV HBM ESD Protection (typ)
 - 2-Pin SFN, 6-Pin TDFN-EP, and 6-Pin TSOC Packages
 - Operating Range: 3.3V ±10%, -40°C to +85°C

Typical Application Circuit

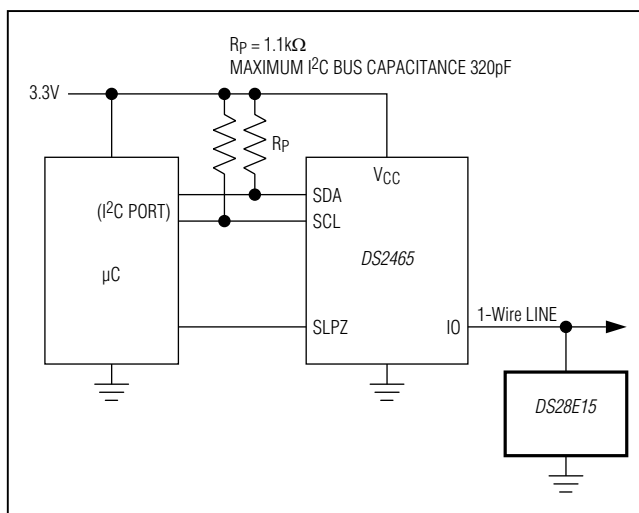

DeepCover is a trademark and 1-Wire is a registered trademark of Maxim Integrated Products, Inc.

ABRIDGED DATA SHEET

DS28E15

DeepCover Secure Authenticator with
1-Wire SHA-256 and 512-Bit User EEPROM

Absolute Maximum Ratings

IO Voltage Range to GND.....-0.5V to +4.0V
IO Sink Current.....20mA
Operating Temperature Range.....-40°C to +85°C
Junction Temperature+150°C

Storage Temperature Range.....-55°C to +125°C
Lead Temperature (TDFN, TSOC only; soldering, 10s)..+300°C
Soldering Temperature (TDFN, TSOC only; reflow).....+260°C

Note: The SFN package is qualified for electro-mechanical contact applications only, not for soldering. For more information, refer to [Application Note 4132: Attachment Methods for the Electro-Mechanical SFN Package](#).

Stresses beyond those listed under "Absolute Maximum Ratings" may cause permanent damage to the device. These are stress ratings only, and functional operation of the device at these or any other conditions beyond those indicated in the operational sections of the specifications is not implied. Exposure to absolute maximum rating conditions for extended periods may affect device reliability.

Electrical Characteristics

(T_A = -40°C to +85°C, unless otherwise noted.) (Note 1)

PARAMETER	SYMBOL	CONDITIONS	MIN	TYP	MAX	UNITS
IO PIN: GENERAL DATA						
1-Wire Pullup Voltage	V _{PUP}	(Note 2)	2.97		3.63	V
1-Wire Pullup Resistance	R _{PUP}	V _{PUP} = 3.3V ±10% (Note 3)	300		1500	Ω
Input Capacitance	C _{IO}	(Notes 4, 5)		1500		pF
Input Load Current	I _L	IO pin at V _{PUP}		5	19.5	μA
High-to-Low Switching Threshold	V _{TL}	(Notes 6, 7)		0.65 x V _{PUP}		V
Input Low Voltage	V _{IL}	(Notes 2, 8)			0.3	V
Low-to-High Switching Threshold	V _{TH}	(Notes 6, 9)		0.75 x V _{PUP}		V
Switching Hysteresis	V _{HY}	(Notes 6, 10)		0.3		V
Output Low Voltage	V _{OL}	I _{OL} = 4mA (Note 11)			0.4	V
Recovery Time	t _{REC}	R _{PUP} = 1500Ω (Notes 2, 12)	5			μs
Time Slot Duration	t _{SLOT}	(Notes 2, 13)	13			μs
IO PIN: 1-Wire RESET, PRESENCE-DETECT CYCLE						
Reset Low Time	t _{RSTL}	(Note 2)	48		80	μs
Reset High Time	t _{RSTH}	(Note 14)	48			μs
Presence-Detect Sample Time	t _{MSP}	(Notes 2, 15)	8		10	μs
IO PIN: 1-Wire WRITE						
Write-Zero Low Time	t _{W0L}	(Notes 2, 16)	8		16	μs
Write-One Low Time	t _{W1L}	(Notes 2, 16)	1		2	μs
IO PIN: 1-Wire READ						
Read Low Time	t _{RL}	(Notes 2, 17)	1		2 - δ	μs
Read Sample Time	t _{MSR}	(Notes 2, 17)	t _{RL} + δ		2	μs

ABRIDGED DATA SHEET

DS28E15

DeepCover Secure Authenticator with
1-Wire SHA-256 and 512-Bit User EEPROM

Electrical Characteristics (continued)

($T_A = -40^{\circ}\text{C}$ to $+85^{\circ}\text{C}$, unless otherwise noted.) (Note 1)

PARAMETER	SYMBOL	CONDITIONS	MIN	TYP	MAX	UNITS
EEPROM						
Programming Current	I_{PROG}	$V_{\text{PUP}} = 3.63\text{V}$ (Notes 5, 18)			1	mA
Programming Time for a 32-Bit Segment or Page Protection	t_{PRD}	Refer to the full data sheet.				ms
Programming Time for the Secret	t_{PRS}					ms
Write/Erase Cycling Endurance	N_{CY}	$T_A = +85^{\circ}\text{C}$ (Notes 21, 22)	100k			—
Data Retention	t_{DR}	$T_A = +85^{\circ}\text{C}$ (Notes 23, 24, 25)	10			Years
SHA-256 ENGINE						
Computation Current	I_{CSHA}	Refer to the full data sheet.				mA
Computation Time	t_{CSHA}					ms

- Note 1:** Limits are 100% production tested at $T_A = +25^{\circ}\text{C}$ and/or $T_A = +85^{\circ}\text{C}$. Limits over the operating temperature range and relevant supply voltage range are guaranteed by design and characterization. Typical values are not guaranteed.
- Note 2:** System requirement.
- Note 3:** Maximum allowable pullup resistance is a function of the number of 1-Wire devices in the system and 1-Wire recovery times. The specified value here applies to systems with only one device and with the minimum 1-Wire recovery times.
- Note 4:** Typical value represents the internal parasitic capacitance when V_{PUP} is first applied. Once the parasitic capacitance is charged, it does not affect normal communication.
- Note 5:** Guaranteed by design and/or characterization only. Not production tested.
- Note 6:** V_{TL} , V_{TH} , and V_{HY} are a function of the internal supply voltage, which is a function of V_{PUP} , R_{PUP} , 1-Wire timing, and capacitive loading on IO. Lower V_{PUP} , higher R_{PUP} , shorter t_{REC} , and heavier capacitive loading all lead to lower values of V_{TL} , V_{TH} , and V_{HY} .
- Note 7:** Voltage below which, during a falling edge on IO, a logic 0 is detected.
- Note 8:** The voltage on IO must be less than or equal to $V_{\text{IL}(\text{MAX})}$ at all times the master is driving IO to a logic 0 level.
- Note 9:** Voltage above which, during a rising edge on IO, a logic 1 is detected.
- Note 10:** After V_{TH} is crossed during a rising edge on IO, the voltage on IO must drop by at least V_{HY} to be detected as logic 0.
- Note 11:** The I-V characteristic is linear for voltages less than 1V.
- Note 12:** Applies to a single device attached to a 1-Wire line.
- Note 13:** Defines maximum possible bit rate. Equal to $1/(t_{\text{WOL}(\text{MIN})} + t_{\text{REC}(\text{MIN})})$.
- Note 14:** An additional reset or communication sequence cannot begin until the reset high time has expired.
- Note 15:** Interval after t_{RSTL} during which a bus master can read a logic 0 on IO if there is a DS28E15 present. The power-up presence detect pulse could be outside this interval but will be complete within 2ms after power-up.
- Note 16:** ϵ in [Figure 11](#) represents the time required for the pullup circuitry to pull the voltage on IO up from V_{IL} to V_{TH} . The actual maximum duration for the master to pull the line low is $t_{\text{W1L}(\text{MAX})} + t_{\text{F}} - \epsilon$ and $t_{\text{WOL}(\text{MAX})} + t_{\text{F}} - \epsilon$, respectively.
- Note 17:** δ in [Figure 11](#) represents the time required for the pullup circuitry to pull the voltage on IO up from V_{IL} to the input-high threshold of the bus master. The actual maximum duration for the master to pull the line low is $t_{\text{RL}(\text{MAX})} + t_{\text{F}}$.
- Note 18:** Current drawn from IO during the EEPROM programming interval or SHA-256 computation. The pullup circuit on IO during the programming interval and SHA-256 computation should be such that the voltage at IO is greater than or equal to 2.0V.
- Note 19: Refer to the full data sheet.**

Note 20: Refer to the full data sheet.

Note 21: Write-cycle endurance is tested in compliance with JESD47G.

Note 22: Not 100% production tested; guaranteed by reliability monitor sampling.

ABRIDGED DATA SHEET

DS28E15

DeepCover Secure Authenticator with
1-Wire SHA-256 and 512-Bit User EEPROM

Electrical Characteristics (continued)

($T_A = -40^{\circ}\text{C}$ to $+85^{\circ}\text{C}$, unless otherwise noted.) (Note 1)

Note 23: Data retention is tested in compliance with JESD47G.

Note 24: Guaranteed by 100% production test at elevated temperature for a shorter time; equivalence of this production test to the data sheet limit at operating temperature range is established by reliability testing.

Note 25: EEPROM writes can become nonfunctional after the data-retention time is exceeded. Long-term storage at elevated temperatures is not recommended.

Note 26: Refer to the full data sheet.

Pin Configurations

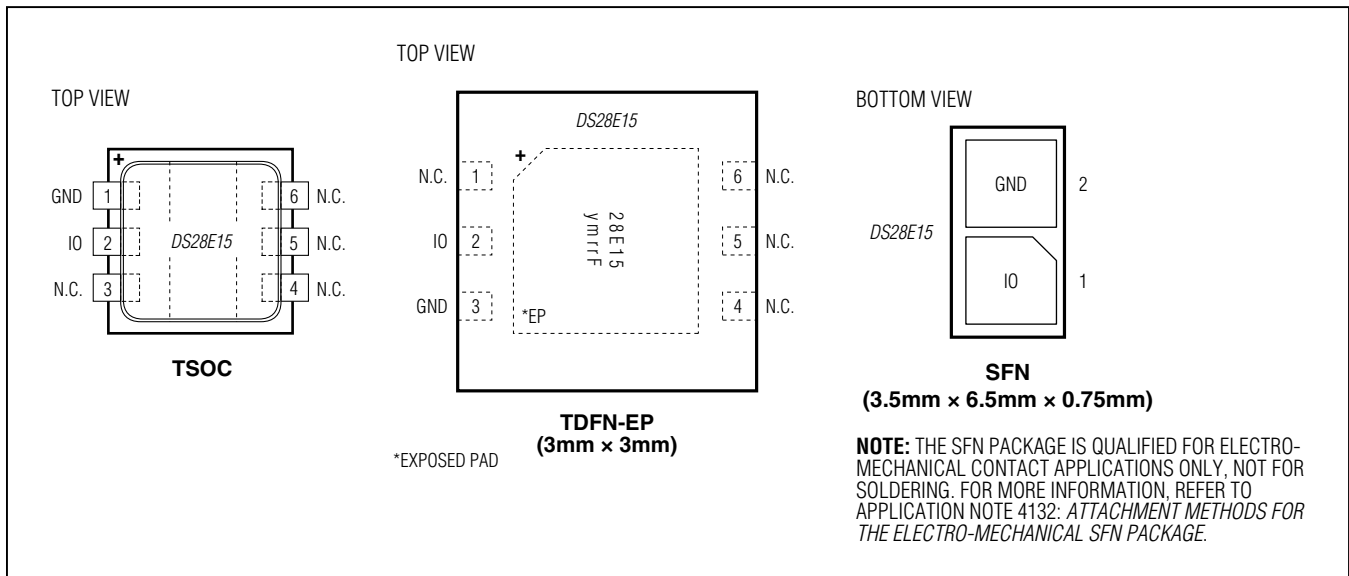

Pin Descriptions

SFN	PIN		NAME	FUNCTION
	TDFN-EP	TSOC		
—	1, 4, 5, 6	3– 6	N.C.	Not Connected
1	2	2	IO	1-Wire Bus Interface. Open-drain signal that requires an external pullup resistor.
2	3	1	GND	Ground Reference
—	—	—	EP	Exposed Pad (TDFN Only). Solder evenly to the board's ground plane for proper operation. Refer to Application Note 3273: <i>Exposed Pads: A Brief Introduction</i> for additional information.

Note to readers: This document is an abridged version of the full data sheet. Additional device information is available only in the full version of the data sheet. To request the full data sheet, go to www.maximintegrated.com/DS28E15 and click on **Request Full Data Sheet**.

Ordering Information

PART	TEMP RANGE	PIN-PACKAGE
DS28E15G+	-40°C to +85°C	2 SFN
DS28E15G+T	-40°C to +85°C	2 SFN (2.5k pcs)
DS28E15Q+T	-40°C to +85°C	6 TDFN-EP* (2.5k pcs)
DS28E15P+	-40°C to +85°C	6 TSOC
DS28E15P+T	-40°C to +85°C	6 TSOC (4k pcs)

+ Denotes a lead(Pb)-free/RoHS-compliant package.

T = Tape and reel.

*EP = Exposed pad.

Package Information

For the latest package outline information and land patterns (footprints), go to www.maximintegrated.com/packages. Note that a "+", "#", or "-" in the package code indicates RoHS status only. Package drawings may show a different suffix character, but the drawing pertains to the package regardless of RoHS status.

PACKAGE TYPE	PACKAGE CODE	OUTLINE NO.	LAND PATTERN NO.
2 SFN	T23A6N+1	21-0575	—
6 TDFN-EP	T633+2	21-0137	90-0058
6 TSOC	D6+1	21-0382	90-0321

For pricing, delivery, and ordering information, please contact Maxim Direct at 1-888-629-4642, or visit Maxim Integrated's website at www.maximintegrated.com.

Maxim Integrated cannot assume responsibility for use of any circuitry other than circuitry entirely embodied in a Maxim Integrated product. No circuit patent licenses are implied. Maxim Integrated reserves the right to change the circuitry and specifications without notice at any time. The parametric values (min and max limits) shown in the Electrical Characteristics table are guaranteed. Other parametric values quoted in this data sheet are provided for guidance.

X-ON Electronics

Largest Supplier of Electrical and Electronic Components

Click to view similar products for [Security ICs / Authentication ICs](#) category:

Click to view products by [Maxim](#) manufacturer:

Other Similar products are found below :

[RJM8L151F6P6R](#) [AT97SC3204T-X2A1B-10](#) [SLS32AIA020A4USON10XTMA2](#) [AT97SC3205T-G3M4C-00](#) [AT97SC3205T-H3M4C-20](#)
[AT97SC3204-U4A14-20](#) [AT97SC3205T-H3M4C20B](#) [AT97SC3205-X3A12-10](#) [AT97SC3204-U2MA-20](#) [AT97SC3204-X2A1A-10](#)
[ATAES132-SH-EQ](#) [ATECC508A-MAHDA-S](#) [DS2401+](#) [DS1990A-F3+](#) [DS1990A-F5+](#) [DS2401P+T&R](#) [DS2401Z+T&R](#) [DS2411P+](#)
[DS2411P+T&R](#) [ATSHA204-TH-CZ-T](#) [DS28CM00R-A00+T](#) [DS28C22Q+T](#) [ATTPM20P-G3MA1-10-B](#) [HCS515-IP](#) [HCS515P](#) [MCS3122-](#)
[I/ST](#) [MIKROE-3047](#) [ATECC508A-SSHDA-T](#) [ATSHA204A-SSHDA-B](#) [ATAES132A-SHEQ-B](#) [ATECC108A-SSHCZ-B](#) [ATSHA204A-](#)
[SSHDA-T](#) [W74M32FVSSIQ](#) [IPL-CHP1.8V](#) [ATSHA204A-STUCZ-T](#) [DS2411R+T&R](#) [RJM8L151K8Q6Y](#) [CW3802](#) [RJGT102WDP8](#)
[FM15160 508-03](#) [RJGT102WDT6](#) [RJMU401FHO](#) [ATECC108A-RBHCHZ-T](#) [IPL-CHP](#) [404726X](#) [AT88SC0808CA-Y6H-T](#) [AT88SA102S-](#)
[SH-T](#) [MAX66240ESA+](#)