



Low-Power, 16-Bit Analog-to-Digital Converters with Parallel Interface

MAX1165/MAX1166

General Description

The MAX1165/MAX1166 16-bit, low-power, successive-approximation analog-to-digital converters (ADCs) feature automatic power-down, factory-trimmed internal clock, and a 16-bit wide (MAX1165) or byte wide (MAX1166) parallel interface. The devices operate from a single +4.75V to +5.25V analog supply and a +2.7V to +5.25V digital supply.

The MAX1165/MAX1166 use an internal 4.096V reference or an external reference. The MAX1165/MAX1166 consume only 1.8mA at a sampling rate of 165ksps with external reference and 2.7mA with internal reference. AutoShutdown™ reduces supply current to 0.1mA at 10ksps.

The MAX1165/MAX1166 are ideal for high-performance, battery-powered, data-acquisition applications. Excellent dynamic performance and low power consumption in a small package make the MAX1165/MAX1166 ideal for circuits with demanding power consumption and space requirements.

The 16-bit wide MAX1165 is available in a 28-pin TSSOP package and the byte wide MAX1166 is available in a 20-pin TSSOP package. Both devices are available in either the 0°C to +70°C commercial, or the -40°C to +85°C extended temperature range.

AutoShutdown is a trademark of Maxim Integrated Products, Inc.

Applications

- Temperature Sensor/Monitor
- Industrial Process Control
- I/O Boards
- Data-Acquisition Systems
- Cable/Harness Tester
- Accelerometer Measurements
- Digital Signal Processing

Pin Configurations and Functional Diagram appear at end of data sheet.

Features

- ◆ 16-Bit Wide (MAX1165) and Byte Wide (MAX1166) Parallel Interface
- ◆ High Speed: 165ksps Sample Rate
- ◆ Accurate: ± 2.5 LSB INL, 16 Bit No Missing Codes
- ◆ 4.096V, 25ppm/°C Internal Reference
- ◆ External Reference Range: +3.8V to +5.25V
- ◆ Single +4.75V to +5.25V Analog Supply Voltage
- ◆ +2.7V to +5.25V Digital Supply Voltage
- ◆ Low Supply Current
 - 1.8mA (External Reference)
 - 2.7mA (Internal Reference)
 - 0.1 μ A (10ksps, External Reference)
- ◆ Small Footprint
 - 28-Pin TSSOP Package (16-Bit Wide)
 - 20-Pin TSSOP Package (Byte Wide)

Ordering Information

PART	TEMP RANGE	PIN-PACKAGE	INL
MAX1165ACUI	0°C to +70°C	28 TSSOP	± 2
MAX1165BCUI	0°C to +70°C	28 TSSOP	± 2
MAX1165CCUI	0°C to +70°C	28 TSSOP	± 4
MAX1165AEUI	-40°C to +85°C	28 TSSOP	± 2.5
MAX1165BEUI	-40°C to +85°C	28 TSSOP	± 2.5
MAX1165CEUI	-40°C to +85°C	28 TSSOP	± 4

Ordering Information continued at end of data sheet.

Typical Operating Circuit

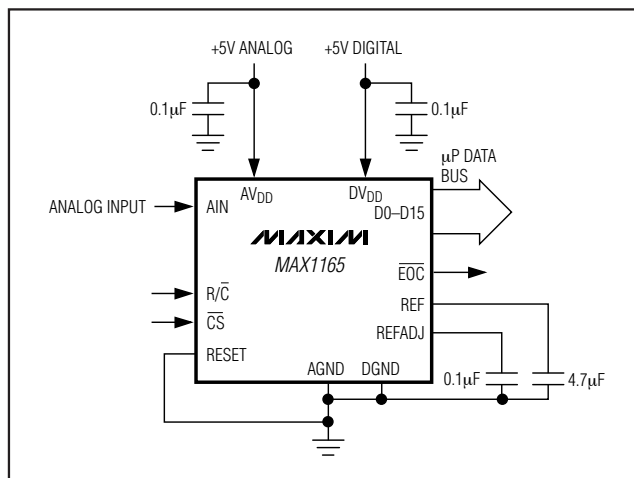

Low-Power, 16-Bit Analog-to-Digital Converter with Parallel Interface

ABSOLUTE MAXIMUM RATINGS

AV _{DD} to AGND	-0.3V to +6V
DV _{DD} to DGND	-0.3V to (AV _{DD} + 0.3V)
AGND to DGND	-0.3V to +0.3V
A _{IN} , REF, REFADJ to AGND	-0.3V to (AV _{DD} + 0.3V)
\overline{CS} , HBEN, R/ \overline{C} , RESET to DGND	-0.3V to +6V
Digital Output (D15–D0, EOC) to DGND	-0.3V to (DV _{DD} + 0.3V)
Maximum Continuous Current Into Any Pin	50mA

Continuous Power Dissipation (T _A = +70°C)	
20-Pin TSSOP (derate 10.9mW/°C above +70°C)	879mW
28-Pin TSSOP (derate 12.8mW/°C above +70°C)	1026mW
Operating Temperature Ranges	
MAX116_CU	0°C to +70°C
MAX116_EU	-40°C to +85°C
Storage Temperature Range	-65°C to +150°C
Junction Temperature	+150°C
Lead Temperature (soldering, 10s)	+300°C

Stresses beyond those listed under "Absolute Maximum Ratings" may cause permanent damage to the device. These are stress ratings only, and functional operation of the device at these or any other conditions beyond those indicated in the operational sections of the specifications is not implied. Exposure to absolute maximum rating conditions for extended periods may affect device reliability.

ELECTRICAL CHARACTERISTICS

(AV_{DD} = DV_{DD} = +5V, external reference = +4.096V, C_{REF} = 4.7μF, C_{REFADJ} = 0.1μF, T_A = T_{MIN} to T_{MAX}, unless otherwise noted. Typical values are at T_A = +25°C.)

PARAMETER	SYMBOL	CONDITIONS		MIN	TYP	MAX	UNITS
DC ACCURACY							
Resolution	N			16			Bits
Relative Accuracy (Note 1)	INL	T _A = -40°C	MAX116_A	-2.5		+2.5	LSB
			MAX116_B	-2.5		+2.5	
			MAX116_C	-4		+4	
		T _A = 0°C	MAX116_A	-2		+2	
			MAX116_B	-2		+2	
			MAX116_C	-4		+4	
		T _A = +85°C	MAX116_A	-2		+2	
			MAX116_B	-2		+2	
			MAX116_C	-4		+4	
Differential Nonlinearity	DNL	T _A = -40°C	No missing codes	MAX116_A	-1	+2	LSB
				MAX116_B	-1	+2	
			MAX116_C	-2	+2		
		T _A = 0°C	No missing codes	MAX116_A	-1	+1.5	
				MAX116_B	-1	+1.5	
			MAX116_C	-2	+2		
		T _A = +85°C	No missing codes	MAX116_A	-1	+1	
				MAX116_B	-1	+1.5	
			MAX116_C	-2	+2		
Transition Noise		RMS noise, external reference, includes quantization noise			0.65		LSBRMS
		Internal reference			0.7		LSBRMS
Offset Error				0.05	1		mV
Gain Error		(Note 2)		±0.002	±0.02		%FSR
Offset Drift					0.6		ppm/°C
Gain Drift					0.2		ppm/°C
DYNAMIC PERFORMANCE (f _{IN(SINE-WAVE)} = 1kHz, V _{IN} = 4.096V _{P-P} , 165ksps)							
Signal-to-Noise Plus Distortion	SINAD			86	90		dB

Low-Power, 16-Bit Analog-to-Digital Converter with Parallel Interface

MAX1165/MAX1166

ELECTRICAL CHARACTERISTICS (continued)

($V_{DD} = DV_{DD} = +5V$, external reference = +4.096V, $C_{REF} = 4.7\mu F$, $C_{REFADJ} = 0.1\mu F$, $T_A = T_{MIN}$ to T_{MAX} , unless otherwise noted. Typical values are at $T_A = +25^\circ C$.)

PARAMETER	SYMBOL	CONDITIONS	MIN	TYP	MAX	UNITS
Signal-to-Noise Ratio	SNR		87	90		dB
Total Harmonic Distortion	THD			-102	-90	dB
Spurious-Free Dynamic Range	SFDR		91	105		dB
Full-Power Bandwidth		-3dB point		4		MHz
Full-Linear Bandwidth		SINAD > 81dB		33		kHz
CONVERSION RATE						
Sample Rate	f_{SAMPLE}				165	ksps
Aperture Delay				27		ns
Aperture Jitter				<100		ps
ANALOG INPUT						
Input Range	V_{AIN}		0		V_{REF}	V
Input Capacitance	C_{AIN}			40		pF
INTERNAL REFERENCE						
REF Output Voltage	V_{REF}		4.054	4.096	4.136	V
REF Output Tempco	TC_{REF}			± 25		ppm/ $^\circ C$
REF Short-Circuit Current	I_{REFSC}			± 10		mA
Capacitive Bypass at REFADJ	C_{REFADJ}		0.1			μF
Capacitive Bypass at REF	C_{REF}		1			μF
REFADJ Input Leakage Current	I_{REFADJ}			20		μA
EXTERNAL REFERENCE						
REFADJ Buffer Disable Threshold		To power down the internal reference	$AV_{DD} - 0.4$		$AV_{DD} - 0.1$	V
REF Input Voltage Range		Internal reference disabled (Note 3)	3.8		$AV_{DD} - 0.2$	V
REF Input Current	I_{REF}	$V_{REF} = +4.096V$, $f_{SAMPLE} = 165ksps$ Shutdown mode		14 ± 0.1	25	μA
DIGITAL INPUTS/OUTPUTS						
Input High Voltage	V_{IH}		$0.7 \times DV_{DD}$			V
Input Low Voltage	V_{IL}				$0.3 \times DV_{DD}$	V
Input Leakage Current	I_{IN}	$V_{IH} = 0$ or DV_{DD}		± 0.1	± 1	μA
Input Hysteresis	V_{HYST}			0.1		V
Input Capacitance	C_{IN}			15		pF
Output High Voltage	V_{OH}	$I_{SOURCE} = 0.5mA$, $DV_{DD} = +2.7V$ to $+5.25V$, $AV_{DD} = +5.25V$	$DV_{DD} - 0.4$			V
Output Low Voltage	V_{OL}	$I_{SINK} = 1.6mA$, $DV_{DD} = +2.7V$ to $+5.25V$, $AV_{DD} = +5.25V$			0.4	V
Three-State Leakage Current	I_{OZ}	D0–D15		± 0.1	± 10	μA

Low-Power, 16-Bit Analog-to-Digital Converter with Parallel Interface

ELECTRICAL CHARACTERISTICS (continued)

($V_{DD} = DV_{DD} = +5V$, external reference = +4.096V, $C_{REF} = 4.7\mu F$, $C_{REFADJ} = 0.1\mu F$, $T_A = T_{MIN}$ to T_{MAX} , unless otherwise noted. Typical values are at $T_A = +25^\circ C$.)

PARAMETER	SYMBOL	CONDITIONS	MIN	TYP	MAX	UNITS
Three-State Output Capacitance	C_{OZ}			15		pF
POWER REQUIREMENTS						
Analog Supply Voltage	V_{DD}		4.75		5.25	V
Digital Supply	DV_{DD}		2.7		V_{DD}	V
Analog Supply Current	I_{AVDD}	Internal reference	165ksps	3.2	3.6	mA
			100ksps	2.6		
			10ksps	1.9		
			1ksps	1.8		
		External reference	165ksps	2.4	2.8	
			100ksps	1.8		
			10ksps	0.8		
			1ksps	0.08		
Digital Supply Current	I_{DVDD}	D0–D15 = all zeros	165ksps	0.5	0.7	mA
			100ksps	0.3		
			10ksps	0.03		
			1ksps	0.003		
Shutdown Supply Current	I_{SHDN}	Full power-down	I_{AVDD}	0.5	5	μA
			I_{DVDD}	0.5	6	
		REF and REF buffer enabled (standby mode)	I_{AVDD}	1.0	1.2	mA
			I_{DVDD} (Note 4)	0.5	5	
Power-Supply Rejection Ratio	PSRR	$V_{DD} = +5V \pm 5\%$, full-scale input (Note 5)		68		dB

TIMING CHARACTERISTICS (Figures 1 and 2)

($V_{DD} = +4.75V$ to $+5.25V$, $DV_{DD} = +2.7V$ to V_{DD} , external reference = +4.096V, $C_{REF} = 4.7\mu F$, $C_{REFADJ} = 0.1\mu F$, $C_{LOAD} = 20pF$, $T_A = T_{MIN}$ to T_{MAX} , unless otherwise noted. Typical values are at $T_A = +25^\circ C$.)

PARAMETER	SYMBOL	CONDITIONS	MIN	TYP	MAX	UNITS
Acquisition Time	t_{ACQ}		1.1			μs
Conversion Time	t_{CONV}				4.7	
\overline{CS} Pulse Width High	t_{CSH}	(Note 6)	40			ns
\overline{CS} Pulse Width Low (Note 6)	t_{CSL}	$V_{DVDD} = 4.75V$ to $5.25V$	40			ns
		$V_{DVDD} = 2.7V$ to $5.25V$	60			
R/\overline{C} to \overline{CS} Fall Setup Time	t_{DS}		0			ns
R/\overline{C} to \overline{CS} Fall Hold Time	t_{DH}	$V_{DVDD} = 4.75V$ to $5.25V$	40			ns
		$V_{DVDD} = 2.7V$ to $5.25V$	60			
\overline{CS} to Output Data Valid	t_{DO}	$V_{DVDD} = 4.75V$ to $5.25V$			40	ns
		$V_{DVDD} = 2.7V$ to $5.25V$			80	
HBEN Transition to Output Data Valid (MAX1166 Only)	t_{DO1}	$V_{DVDD} = 4.75V$ to $5.25V$			40	ns
		$V_{DVDD} = 2.7V$ to $5.25V$			80	
\overline{EOC} Fall to \overline{CS} Fall	t_{DV}		0			ns

Low-Power, 16-Bit Analog-to-Digital Converter with Parallel Interface

MAX1165/MAX1166

TIMING CHARACTERISTICS (Figures 1 and 2) (continued)

($V_{DD} = +4.75V$ to $+5.25V$, $DV_{DD} = +2.7V$ to AV_{DD} , external reference = $+4.096V$, $C_{REF} = 4.7\mu F$, $C_{REFADJ} = 0.1\mu F$, $C_{LOAD} = 20pF$, $T_A = T_{MIN}$ to T_{MAX} , unless otherwise noted. Typical values are at $T_A = +25^\circ C$.)

PARAMETER	SYMBOL	CONDITIONS	MIN	TYP	MAX	UNITS
\overline{CS} Rise to \overline{EOC} Rise	t_{EOC}	$V_{DVDD} = 4.75V$ to $5.25V$			40	ns
		$V_{DVDD} = 2.7V$ to $5.25V$			80	
Bus Relinquish Time (Note 6)	t_{BR}	$V_{DVDD} = 4.75V$ to $5.25V$			40	ns
		$V_{DVDD} = 2.7V$ to $5.25V$			80	

Note 1: Relative accuracy is the deviation of the analog value at any code from its theoretical value after offset and gain errors have been removed.

Note 2: Offset nulled.

Note 3: Guaranteed by design, not production tested.

Note 4: Shutdown supply currents are typically $0.5\mu A$, maximum specification is limited by automated test equipment.

Note 5: Defined as the change in positive full scale caused by a $\pm 5\%$ variation in the nominal supply.

Note 6: To ensure best performance, finish reading the data and wait t_{BR} before starting a new acquisition.

Typical Operating Characteristics

($AV_{DD} = DV_{DD} = +5V$, external reference = $+4.096V$, $C_{REF} = 4.7\mu F$, $C_{REFADJ} = 0.1\mu F$, $T_A = +25^\circ C$, unless otherwise noted.)

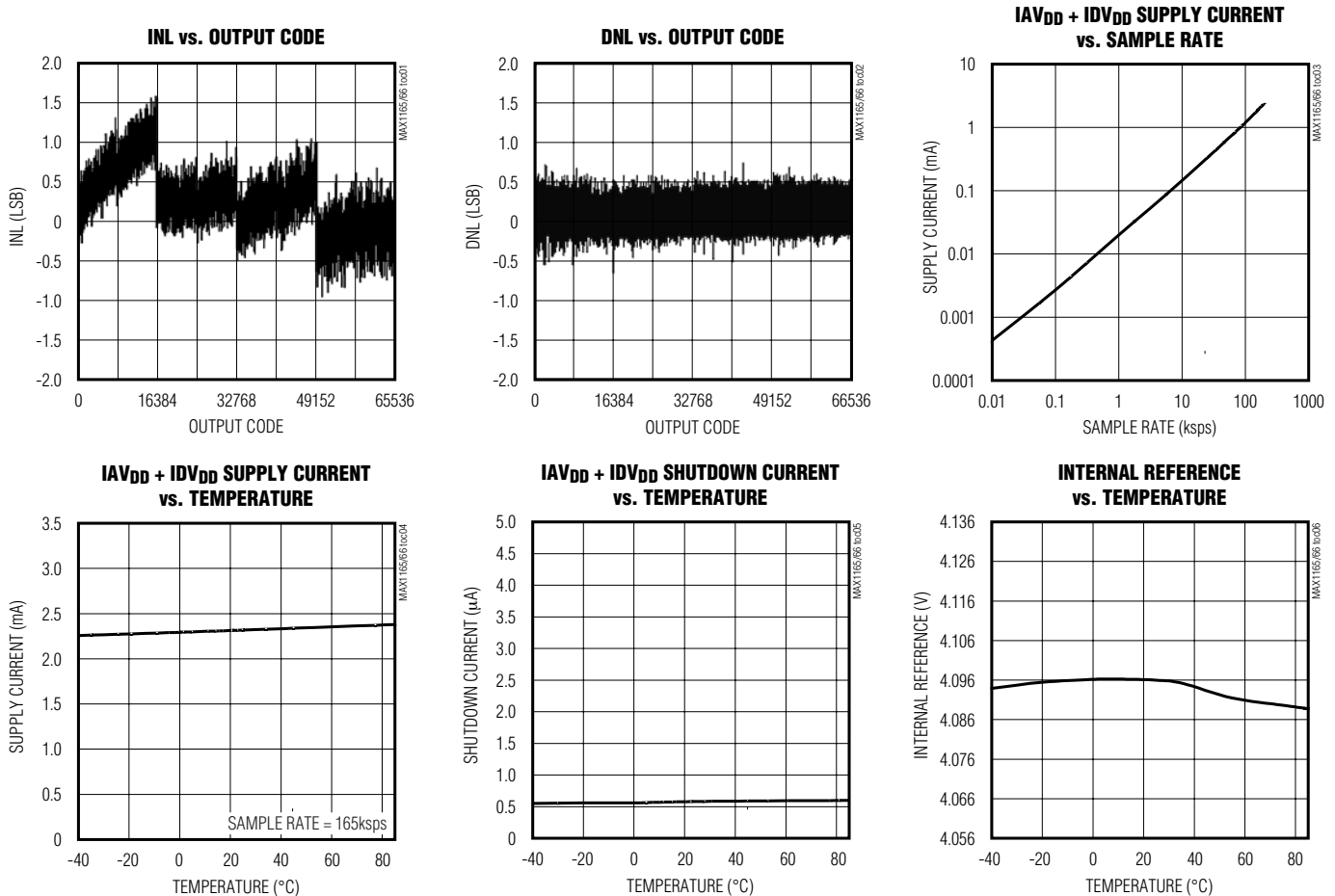

Low-Power, 16-Bit Analog-to-Digital Converter with Parallel Interface

Typical Operating Characteristics (continued)

($V_{DD} = DV_{DD} = +5V$, external reference = +4.096V, $C_{REF} = 4.7\mu F$, $C_{REFADJ} = 0.1\mu F$, $T_A = +25^\circ C$, unless otherwise noted.)

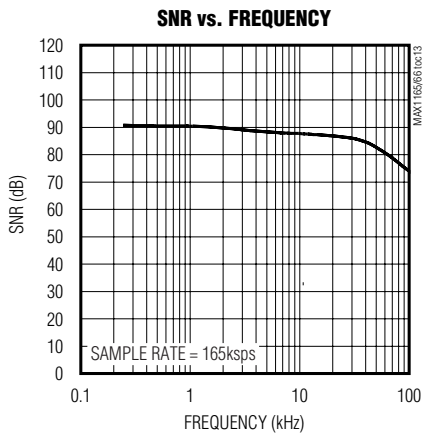
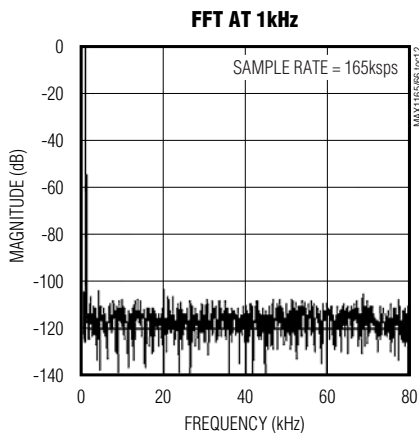
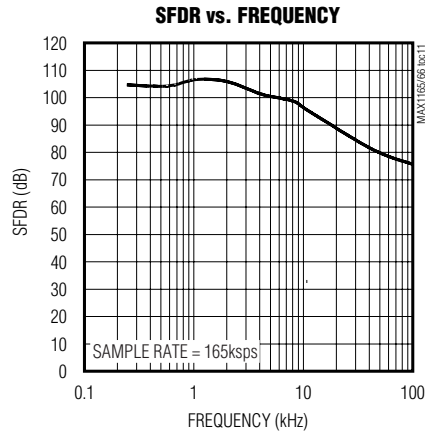
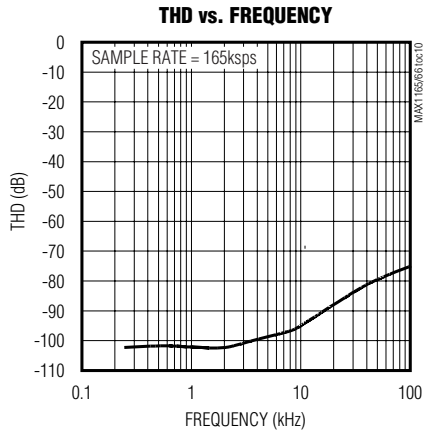
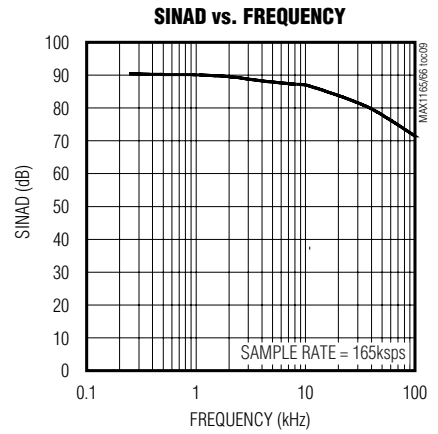
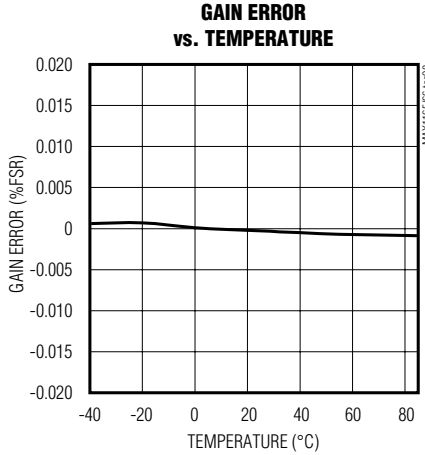
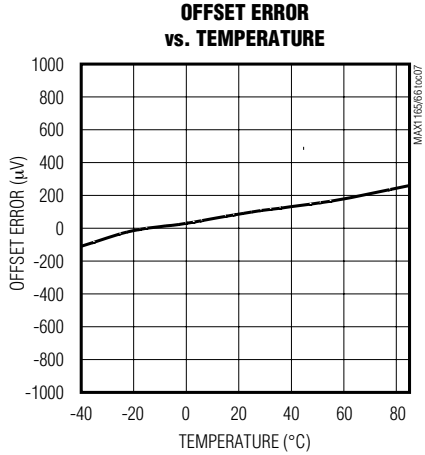

Low-Power, 16-Bit Analog-to-Digital Converter with Parallel Interface

Pin Description

MAX1165/MAX1166

PIN		NAME		FUNCTION
MAX1165	MAX1166	MAX1165	MAX1166	
1	1	D8	D4/D12	Three-State Digital Data Output
2	2	D9	D5/D13	Three-State Digital Data Output
3	3	D10	D6/D14	Three-State Digital Data Output
4	4	D11	D7/D15	Three-State Digital Data Output. D15 is the MSB.
5	—	D12	—	Three-State Digital Data Output
6	—	D13	—	Three-State Digital Data Output
7	—	D14	—	Three-State Digital Data Output
8	—	D15	—	Three-State Digital Data Output (MSB)
9	5	R/C		Read/Convert Input. Power up and put the MAX1165/MAX1166 in acquisition mode by holding R/C low during the first falling edge of CS. During the second falling edge of CS, the level on R/C determines whether the reference and reference buffer power down or remain on after conversion. Set R/C high during the second falling edge of CS to power down the reference and buffer, or set R/C low to leave the reference and buffer powered up. Set R/C high during the third falling edge of CS to put valid data on the bus.
10	6	EOC		End of Conversion. EOC drives low when conversion is complete.
11	7	AVDD		Analog Supply Input. Bypass with a 0.1µF capacitor to AGND.
12	8	AGND		Analog Ground. Primary analog ground (star ground).
13	9	AIN		Analog Input
14	10	AGND		Analog Ground. Connect pin 14 to pin 12 (MAX1165). Connect pin 10 to pin 8 (MAX1166).
15	11	REFADJ		Reference Buffer Output. Bypass REFADJ with a 0.1µF capacitor to AGND for internal reference mode. Connect REFADJ to AVDD to select external reference mode.
16	12	REF		Reference Input/Output. Bypass REF with a 4.7µF capacitor to AGND for internal reference mode. External reference input when in external reference mode.
17	—	RESET		Reset Input. Logic high resets the device.
—	13	HBEN		High-Byte Enable Input. Used to multiplex the 14-bit conversion result: 1: Most significant byte available on the data bus. 0: Least significant byte available on the data bus.
18	14	CS		Convert Start. The first falling edge of CS powers up the device and enables acquire mode when R/C is low. The second falling edge of CS starts conversion. The third falling edge of CS loads the result onto the bus when R/C is high.
19	15	DGND		Digital Ground
20	16	DVDD		Digital Supply Voltage. Bypass with a 0.1µF capacitor to DGND.
21	17	D0	D0/D8	Three-State Digital Data Output
22	18	D1	D1/D9	Three-State Digital Data Output
23	19	D2	D2/D10	Three-State Digital Data Output
24	20	D3	D3/D11	Three-State Digital Data Output
25	—	D4	—	Three-State Digital Data Output
26	—	D5	—	Three-State Digital Data Output
27	—	D6	—	Three-State Digital Data Output
28	—	D7	—	Three-State Digital Data Output

Low-Power, 16-Bit Analog-to-Digital Converter with Parallel Interface

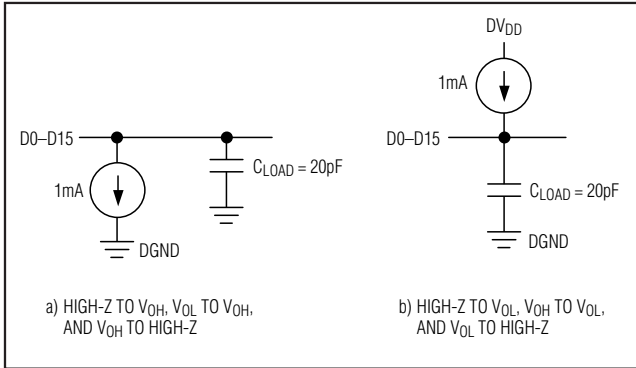

Figure 1. Load Circuits

Detailed Description

Converter Operation

The MAX1165/MAX1166 use a successive-approximation (SAR) conversion technique with an inherent track-and-hold (T/H) stage to convert an analog input into a 16-bit digital output. Parallel outputs provide a high-speed interface to most microprocessors (μ Ps). The *Functional Diagram* shows a simplified internal architecture of the MAX1165/MAX1166. Figure 3 shows a typical application circuit for the MAX1166.

Analog Input

The equivalent input circuit is shown in Figure 4. A switched capacitor digital-to-analog converter (DAC) provides an inherent T/H function. The single-ended input is connected between AIN and AGND.

Input Bandwidth

The ADC's input-tracking circuitry has a 4MHz small-signal bandwidth, so it is possible to digitize high-speed transient events and measure periodic signals with bandwidths exceeding the ADC's sampling rate by using undersampling techniques. To avoid aliasing of unwanted high-frequency signals into the frequency band of interest, use anti-alias filtering.

Analog Input Protection

Internal protection diodes, which clamp the analog input to AV_{DD} and/or AGND, allow the input to swing from AGND - 0.3V to AV_{DD} + 0.3V, without damaging the device.

If the analog input exceeds 300mV beyond the supplies, limit the input current to 10mA.

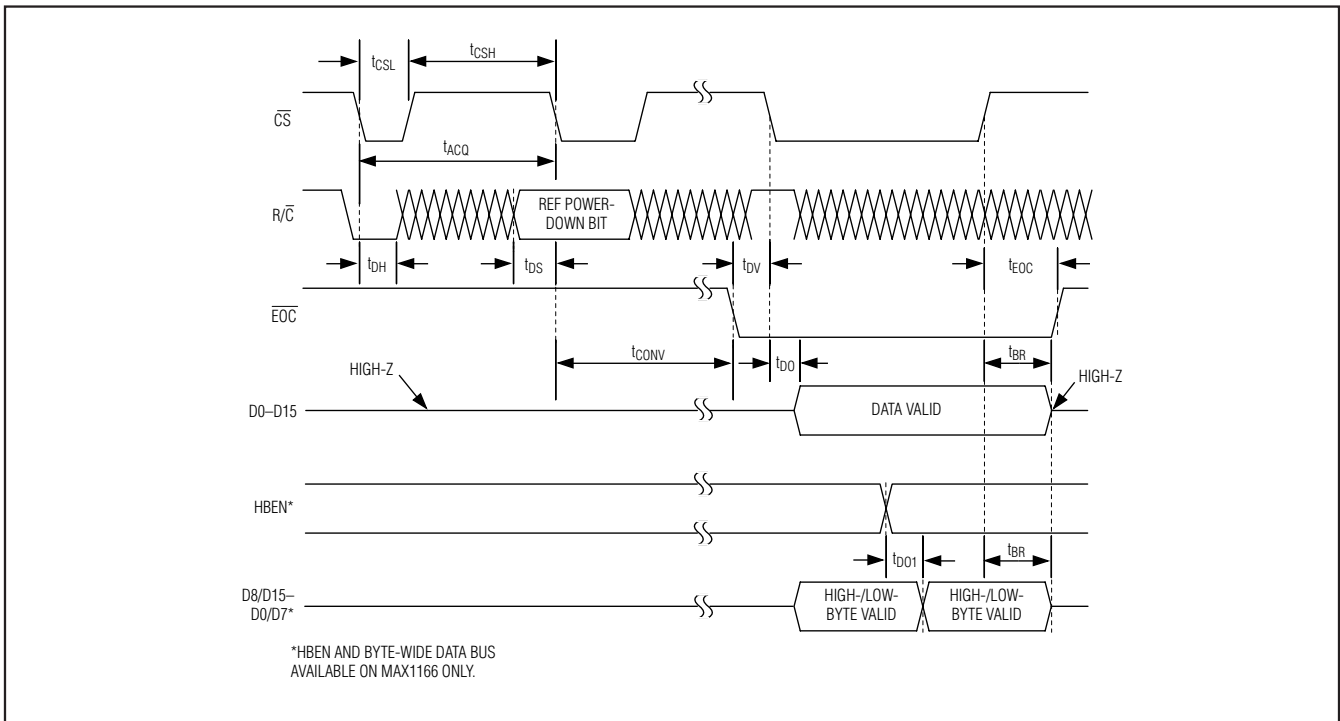

Figure 2. MAX1165/MAX1166 Timing Diagram

Low-Power, 16-Bit Analog-to-Digital Converter with Parallel Interface

MAX1165/MAX1166

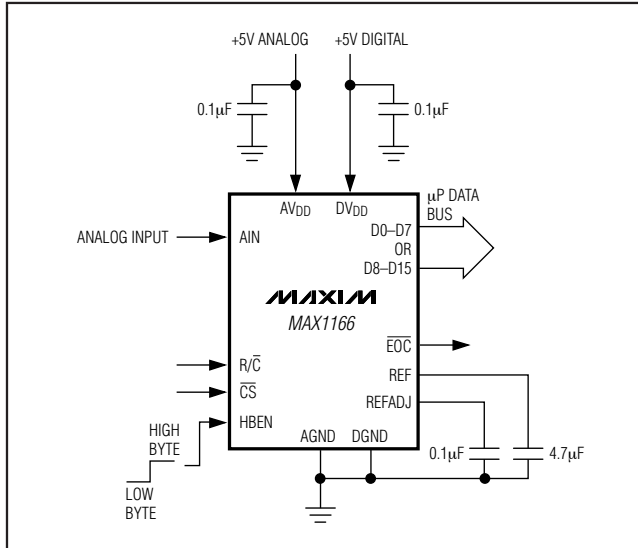

Figure 3. Typical Application Circuit for the MAX1166

Track and Hold (T/H)

In track mode, the analog signal is acquired on the internal hold capacitor. In hold mode, the T/H switches open and the capacitive DAC samples the analog input.

During the acquisition, the analog input (AIN) charges capacitor C_{DAC} . The acquisition ends on the second falling edge of \overline{CS} . At this instant, the T/H switches open. The retained charge on C_{DAC} represents a sample of the input.

In hold mode, the capacitive DAC adjusts during the remainder of the conversion time to restore node ZERO to zero within the limits of 16-bit resolution. Force \overline{CS} low to put valid data on the bus at the end of the conversion.

The time required for the T/H to acquire an input signal is a function of how quickly its input capacitance is charged. If the input signal's source impedance is high, the acquisition time lengthens and more time must be allowed between conversions. The acquisition time (t_{ACQ}) is the maximum time the device takes to acquire the signal. Use the following formula to calculate acquisition time:

$$t_{ACQ} = 11 (R_S + R_{IN}) \times 35pF$$

where $R_{IN} = 800\Omega$, R_S = the input signal's source impedance, and t_{ACQ} is never less than 1.1µs. A source impedance less than 1kΩ does not significantly affect the ADC's performance.

To improve the input signal bandwidth under AC conditions, drive AIN with a wideband buffer (>4MHz) that can drive the ADC's input capacitance and settle quickly.

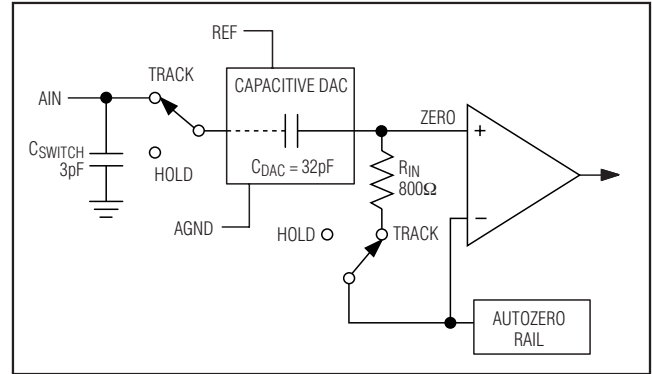

Figure 4. Equivalent Input Circuit

Power-Down Modes

Select standby mode or shutdown mode with the $\overline{R/C}$ bit during the second falling edge of \overline{CS} (see the *Selecting Standby or Shutdown Mode* section). The MAX1165/MAX1166 automatically enter either standby mode (reference and buffer on) or shutdown (reference and buffer off) after each conversion depending on the status of $\overline{R/C}$ during the second falling edge of \overline{CS} .

Internal Clock

The MAX1165/MAX1166 generate an internal conversion clock. This frees the microprocessor from the burden of running the SAR conversion clock. Total conversion time after entering hold mode (second falling edge of \overline{CS}) to end of conversion (\overline{EOC}) falling is 4.7µs (max).

Applications Information

Starting a Conversion

\overline{CS} and $\overline{R/C}$ control acquisition and conversion in the MAX1165/MAX1166 (Figure 2). The first falling edge of \overline{CS} powers up the device and puts it in acquire mode if $\overline{R/C}$ is low. The convert start is ignored if $\overline{R/C}$ is high. The MAX1165/MAX1166 need at least 10ms ($C_{REFADJ} = 0.1\mu F$, $C_{REF} = 4.7\mu F$) for the internal reference to wake up and settle before starting the conversion if powering up from shutdown. The ADC can wake up, from shutdown, to an unknown state. Put the ADC in a known state by completing one "dummy" conversion. The MAX1165/MAX1166 are in a known state, ready for actual data acquisition, after the completion of the dummy conversion. A dummy conversion consists of one full conversion cycle.

The MAX1165 provides an alternative reset function to reset the device (see the *RESET* section).

Low-Power, 16-Bit Analog-to-Digital Converter with Parallel Interface

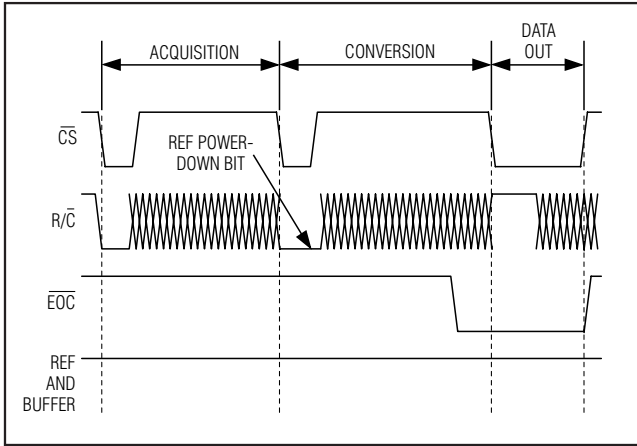

Figure 5. Selecting Standby Mode

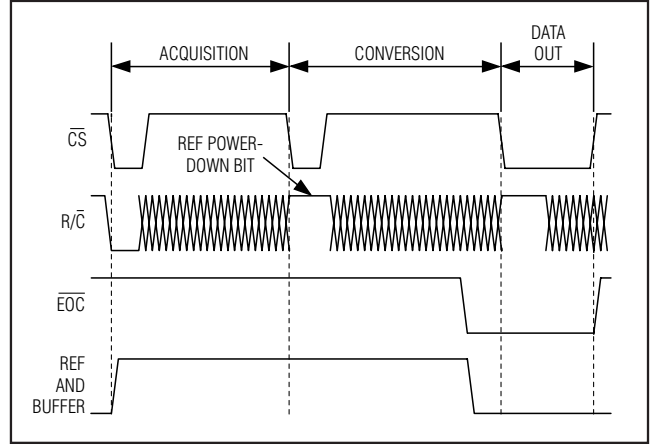

Figure 6. Selecting Shutdown Mode

Selecting Standby or Shutdown Mode

The MAX1165/MAX1166 have a selectable standby or low-power shutdown mode. In standby mode, the ADC's internal reference and reference buffer do not power down between conversions, eliminating the need to wait for the reference to power up before performing the next conversion. Shutdown mode powers down the reference and reference buffer after completing a conversion. The reference and reference buffer require a minimum of 10ms ($C_{REFADJ} = 0.1\mu\text{F}$, $C_{REF} = 4.7\mu\text{F}$) to power up and settle from shutdown.

The state of R/\bar{C} at the second falling edge of \bar{CS} selects which power-down mode the MAX1165/MAX1166 enter upon conversion completion. Holding R/\bar{C} low causes the MAX1165/MAX1166 to enter standby mode. The reference and buffer are left on after the conversion completes. R/\bar{C} high causes the MAX1165/MAX1166 to enter shutdown mode and shut down the reference and buffer after conversion (Figures 5 and 6). When using an external reference, set the REF power-down bit high for lowest current operation.

Standby Mode

While in standby mode, the supply current is reduced to less than 1mA (typ). The next falling edge of \bar{CS} with R/\bar{C} low causes the MAX1165/MAX1166 to exit standby mode and begin acquisition. The reference and reference buffer remain active to allow quick turn-on time. Standby mode allows significant power savings while running at the maximum sample rate.

Shutdown Mode

In shutdown mode, the reference and reference buffer are shut down between conversions. Shutdown mode reduces supply current to 0.5 μA (typ) immediately after the conversion. The falling edge of \bar{CS} with R/\bar{C} low

causes the reference and buffer to wake up and enter acquisition mode. To achieve 16-bit accuracy, allow 10ms ($C_{REFADJ} = 0.1\mu\text{F}$, $C_{REF} = 4.7\mu\text{F}$) for the internal reference to wake up.

Internal and External Reference

Internal Reference

The internal reference of the MAX1165/MAX1166 is internally buffered to provide +4.096V output at REF. Bypass REF to AGND and REFADJ to AGND with 4.7 μF and 0.1 μF , respectively.

Fine adjustments can be made to the internal reference voltage by sinking or sourcing current at REFADJ. The input impedance of REFADJ is nominally 5k Ω . The internal reference voltage is adjustable to $\pm 1.5\%$ with the circuit of Figure 7.

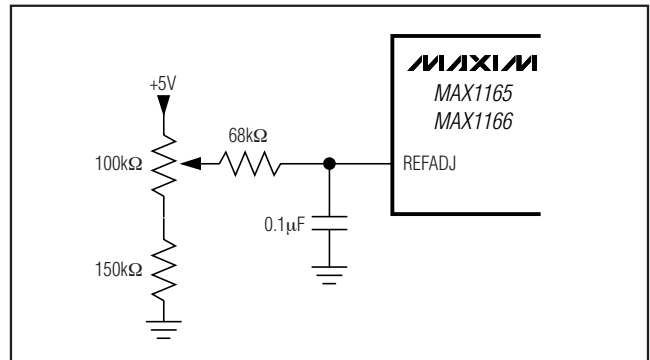

Figure 7. MAX1165/MAX1166 Reference Adjust Circuit

External Reference

An external reference can be placed at either the input (REFADJ) or the output (REF) of the MAX1165/MAX1166s' internal buffer amplifier. When connecting an

Low-Power, 16-Bit Analog-to-Digital Converter with Parallel Interface

external reference to REFADJ, the input impedance is typically $5k\Omega$. Using the buffered REFADJ input makes buffering the external reference unnecessary; however, the internal buffer output must be bypassed at REF with a $1\mu F$ capacitor.

Connect REFADJ to AV_{DD} to disable the internal buffer. Directly drive REF using an external reference. During conversion the external reference must be able to drive $100\mu A$ of DC load current and have an output impedance of 10Ω or less. REFADJ's impedance is typically $5k\Omega$. The DC input impedance of REF is a minimum $40k\Omega$.

For optimal performance, buffer the reference through an op amp and bypass REF with a $1\mu F$ capacitor. Consider the MAX1165/MAX1166s' equivalent input noise ($38\mu V_{RMS}$) when choosing a reference.

Reading a Conversion Result

\overline{EOC} is provided to flag the microprocessor when a conversion is complete. The falling edge of \overline{EOC} signals that the data is valid and ready to be output to the bus.

D0–D15 are the parallel outputs of the MAX1165/MAX1166. These three-state outputs allow for direct connection to a microcontroller I/O bus. The outputs remain high-impedance during acquisition and conversion. Data is loaded onto the bus with the third falling edge of \overline{CS} with R/\overline{C} high after t_{DQ} . Bringing \overline{CS} high forces the output bus back to high impedance. The MAX1165/MAX1166 then wait for the next falling edge of \overline{CS} to start the next conversion cycle (Figure 2).

The MAX1165 loads the conversion result onto a 16-bit wide data bus while the MAX1166 has a byte-wide output format. HBEN toggles the output between the most/least significant byte. The least significant byte is loaded onto the output bus when HBEN is low and the most significant byte is on the bus when HBEN is high (Figure 2).

RESET

Toggle RESET with \overline{CS} high. The next falling edge of \overline{CS} begins acquisition. This reset is an alternative to the dummy conversion explained in the *Starting a Conversion* section.

Transfer Function

Figure 8 shows the MAX1165/MAX1166 output transfer function. The output is coded in standard binary.

Input Buffer

Most applications require an input buffer amplifier to achieve 16-bit accuracy. If the input signal is multi-

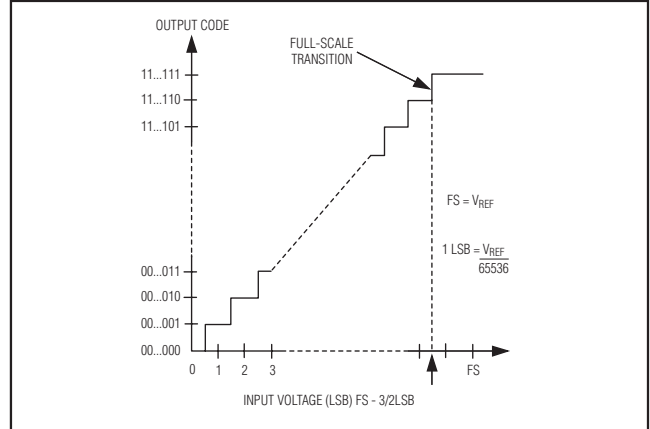

Figure 8. MAX1165/MAX1166 Transfer Function

plexed, the input channel should be switched immediately after acquisition, rather than near the end of or after a conversion. This allows more time for the input buffer amplifier to respond to a large step change in input signal. The input amplifier must have a high enough slew rate to complete the required output voltage change before the beginning of the acquisition time. At the beginning of acquisition, the internal sampling capacitor array connects to AIN (the amplifier output), causing some output disturbance. Ensure that the sampled voltage has settled to within the required limits before the end of the acquisition time. If the frequency of interest is low, AIN can be bypassed with a large enough capacitor to charge the internal sampling capacitor with very little ripple. However, for AC use, AIN must be driven by a wideband buffer (at least $10MHz$), which must be stable with the ADC's capacitive load (in parallel with any AIN bypass capacitor used) and also settle quickly. An example of this circuit using the MAX4434 is given in Figure 9.

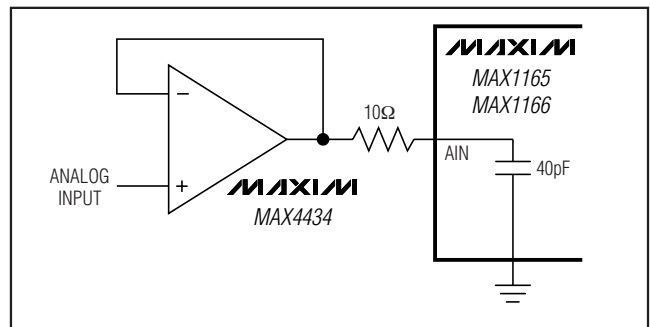

Figure 9. MAX1165/MAX1166 Fast Settling Input Buffer

Low-Power, 16-Bit Analog-to-Digital Converter with Parallel Interface

Layout, Grounding, and Bypassing

For best performance, use printed circuit boards. Do not run analog and digital lines parallel to each other, and do not lay out digital signal paths underneath the ADC package. Use separate analog and digital ground planes with only one point connecting the two ground systems (analog and digital) as close to the device as possible.

Route digital signals far away from sensitive analog and reference inputs. If digital lines must cross analog lines, do so at right angles to minimize coupling digital noise onto the analog lines. If the analog and digital sections share the same supply, then isolate the digital and analog supply by connecting them with a low-value (10 Ω) resistor or ferrite bead.

The ADC is sensitive to high-frequency noise on the AV_{DD} supply. Bypass AV_{DD} to AGND with a 0.1 μ F capacitor in parallel with a 1 μ F to 10 μ F low-ESR capacitor with the smallest capacitor closest to the device. Keep capacitor leads short to minimize stray inductance.

Definitions

Integral Nonlinearity

Integral nonlinearity (INL) is the deviation of the values on an actual transfer function from a straight line. This straight line can be either a best-straight-line fit or a line drawn between the end points of the transfer function, once offset and gain errors have been nullified. The static linearity parameters for the MAX1165/MAX1166 are measured using the end-point method.

Differential Nonlinearity

Differential nonlinearity (DNL) is the difference between an actual step width and the ideal value of 1 LSB. A DNL error specification of ± 1 LSB guarantees no missing codes and a monotonic transfer function.

Aperture Jitter and Delay

Aperture jitter is the sample-to-sample variation in the time between samples. Aperture delay is the time between the rising edge of the sampling clock and the instant when the actual sample is taken.

Signal-to-Noise Ratio

For a waveform perfectly reconstructed from digital samples, signal-to-noise ratio (SNR) is the ratio of the full-scale analog input (RMS value) to the RMS quantization error (residual error). The ideal, theoretical minimum analog-to-digital noise is caused by quantization

noise error only and results directly from the ADC's resolution (N bits):

$$\text{SNR} = (6.02 \times N + 1.76)\text{dB}$$

where N = 16 bits.

In reality, there are other noise sources besides quantization noise: thermal noise, reference noise, clock jitter, etc. SNR is computed by taking the ratio of the RMS signal to the RMS noise, which includes all spectral components minus the fundamental, the first five harmonics, and the DC offset.

Signal-to-Noise Plus Distortion

Signal-to-noise plus distortion (SINAD) is the ratio of the fundamental input frequency's RMS amplitude to the RMS equivalent of all the other ADC output signals:

$$\text{SINAD (dB)} = 20 \times \log \left[\frac{\text{Signal}_{\text{RMS}}}{(\text{Noise} + \text{Distortion})_{\text{RMS}}} \right]$$

Effective Number of Bits

Effective number of bits (ENOB) indicates the global accuracy of an ADC at a specific input frequency and sampling rate. An ideal ADC's error consists of quantization noise only. With an input range equal to the full-scale range of the ADC, calculate the effective number of bits as follows:

$$\text{ENOB} = \frac{\text{SINAD} - 1.76}{6.02}$$

Total Harmonic Distortion

Total harmonic distortion (THD) is the ratio of the RMS sum of the first five harmonics of the input signal to the fundamental itself. This is expressed as:

$$\text{THD} = 20 \times \log \left[\frac{\left(\sqrt{V_2^2 + V_3^2 + V_4^2 + V_5^2} \right)}{V_1} \right]$$

where V₁ is the fundamental amplitude and V₂ through V₅ are the 2nd- through 5th-order harmonics.

Spurious-Free Dynamic Range

Spurious-free dynamic range (SFDR) is the ratio of the RMS amplitude of the fundamental (maximum signal component) to the RMS value of the next largest frequency component.

Low-Power, 16-Bit Analog-to-Digital Converter with Parallel Interface

Functional Diagram

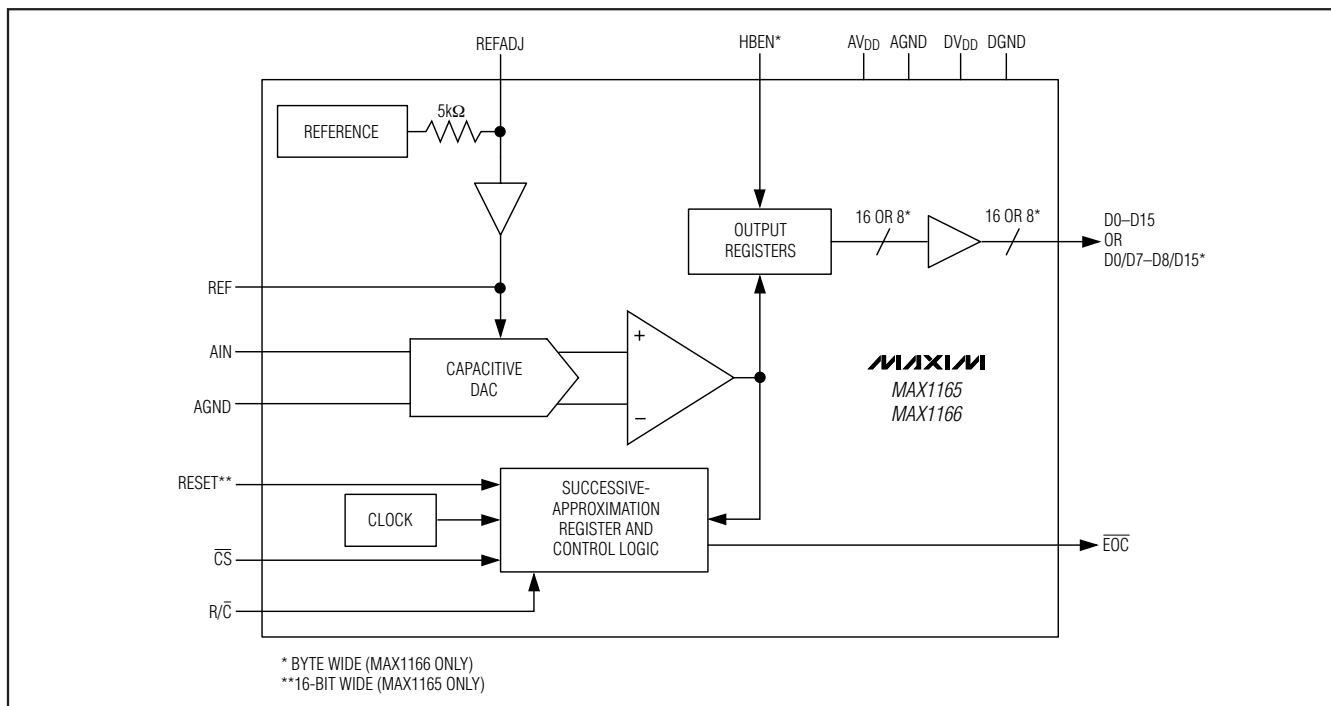

MAX1165/MAX1166

Ordering Information (continued)

PART	TEMP RANGE	PIN-PACKAGE	INL
MAX1166ACUP	0°C to +70°C	20 TSSOP	±2
MAX1166BCUP	0°C to +70°C	20 TSSOP	±2
MAX1166CCUP	0°C to +70°C	20 TSSOP	±4
MAX1166AEUP	-40°C to +85°C	20 TSSOP	±2.5
MAX1166BEUP	-40°C to +85°C	20 TSSOP	±2.5
MAX1166CEUP	-40°C to +85°C	20 TSSOP	±4

Chip Information

TRANSISTOR COUNT: 15,140
PROCESS: BiCMOS

Low-Power, 16-Bit Analog-to-Digital Converter with Parallel Interface

Pin Configurations

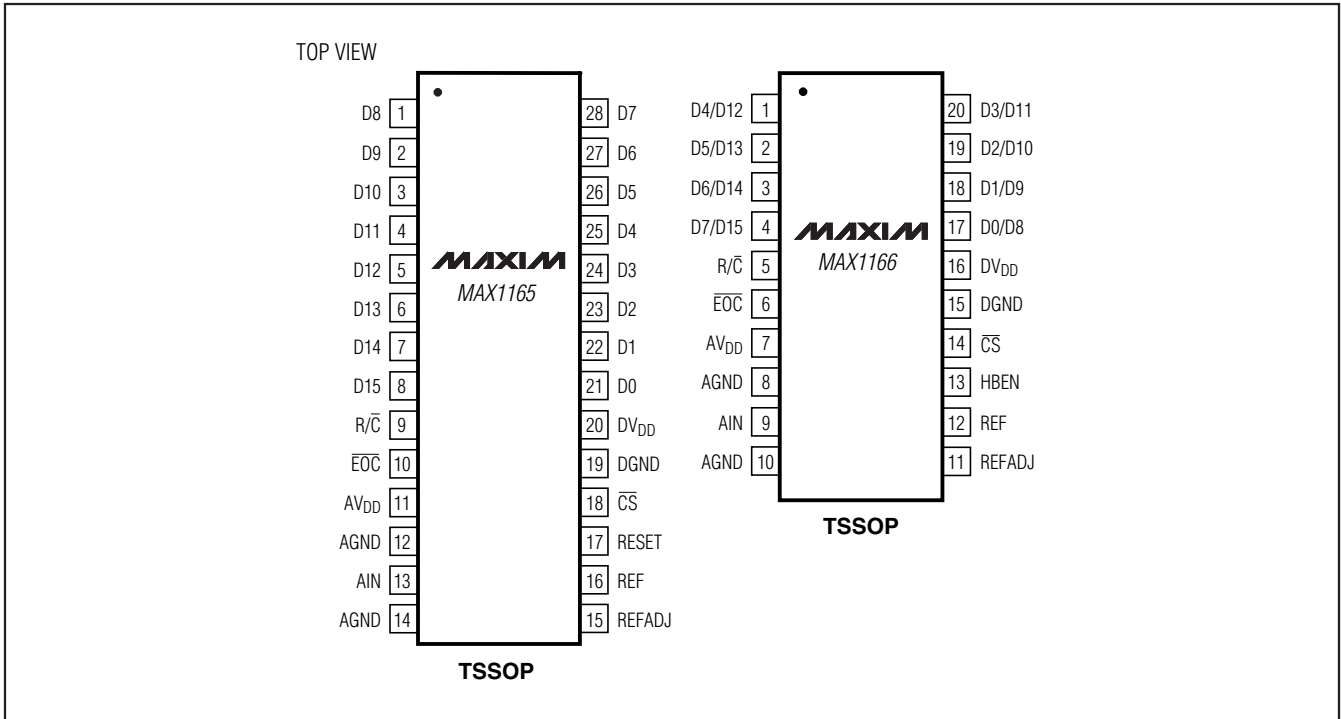

Package Information

For the latest package outline information and land patterns, go to www.maxim-ic.com/packages.

PACKAGE TYPE	PACKAGE CODE	DOCUMENT NO.
28 TSSOP	U28-1	21-0066
20 TSSOP	U20-2	21-0066

Low-Power, 16-Bit Analog-to-Digital Converter with Parallel Interface

Revision History

REVISION NUMBER	REVISION DATE	DESCRIPTION	PAGES CHANGED
0	7/02	Initial release	—
1	2/07	Modified specifications due to inclusion of reference buffer	1–4, 13, 15
2	8/08	Modified specifications for GBD at -40°C	1, 2, 3, 13

MAX1165/MAX1166

Maxim cannot assume responsibility for use of any circuitry other than circuitry entirely embodied in a Maxim product. No circuit patent licenses are implied. Maxim reserves the right to change the circuitry and specifications without notice at any time.

Maxim Integrated Products, 120 San Gabriel Drive, Sunnyvale, CA 94086 408-737-7600 _____ 15

X-ON Electronics

Largest Supplier of Electrical and Electronic Components

Click to view similar products for [Analog to Digital Converters - ADC category](#):

Click to view products by [Maxim manufacturer](#):

Other Similar products are found below :

[ADC0804LCD](#) [ADC0808](#) [MCP37211-200I/TE](#) [MAX15511TGTL+](#) [MCP3202T-CI/MS](#) [ADE1201ACCZ](#) [ADE1202ACCZ](#) [LTC1090CN](#)
[LTC1605IG](#) [LTC2238IUH](#) [LTC1418AIG](#) [LTC1605ACG](#) [LTC1605AIG](#) [LTC2208IUP](#) [ADS1282HPW](#) [LTC1297DCN8](#) [LTC1741CFW](#)
[MCP3422A0-E/MS](#) [MCP3426A2-E/MC](#) [MCP3426A3-E/MC](#) [MCP3427-E/MF](#) [TLC0820ACN](#) [TLC2543IN](#) [TLV2543IDW](#)
[NCD9830DBR2G](#) [ADS5231IPAG](#) [ADS7807U](#) [ADS7891IPFBT](#) [ADS8328IBPW](#) [AMC1204BDWR](#) [ADS7959QDBTRQ1](#)
[ADS7955QDBTRQ1](#) [ADS7807UB](#) [ADS7805UB](#) [ADS1220IPWR](#) [MCP3426A0-E/MS](#) [MCP3422A0-E/MC](#) [AD9220AR](#) [MAX11212AEUB+](#)
[TLV1570CDW](#) [TLC3574IDWR](#) [TLC1542IDWR](#) [TLC0838CDWR](#) [AD7914BRUZ-REEL7](#) [AD977ABRZ](#) [ADC12130CIWM/NOPB](#)
[MCP3426A1-EMC](#) [MCP3426A0-EMC](#) [AD7192BRUZ-REEL](#) [AD7193BRUZ-REEL](#)