

## MAX13035E Evaluation Kit

Evaluates: MAX13035E

### General Description

The MAX13035E evaluation kit (EV kit) demonstrates the MAX13035E 6-channel, bidirectional logic-level translator used for interfacing with secure digital (SD) memory cards. The EV kit features SD memory card interface and general-purpose interface connections. The MAX13035E IC guarantees data rates up to 100Mbps. The MAX13035E translates between  $V_L$  and  $V_{CC}$  logic levels. The  $V_L$  range is 1.62V to 3.2V and the  $\pm 15$ kV ESD-protected  $V_{CC}$  range is 2.2V to 3.6V.

The EV kit also includes the MAX3202E, a dual-channel ESD protection array for complete line protection.

### Component List

DESIGNATION	QTY	DESCRIPTION
C1, C2	2	4.7 $\mu$ F $\pm 10\%$ , 6.3V X5R ceramic capacitors (0603) Murata GRM188R60J475K
C3, C5, C8	3	1 $\mu$ F $\pm 10\%$ , 10V X5R ceramic capacitors (0603) Murata GRM188R61A105K
C4, C6, C7	3	0.1 $\mu$ F $\pm 10\%$ , 10V X5R ceramic capacitors (0402) Murata GRM155R61A104K
J1	1	2 x 11-pin header
J2	1	SD/MMC 9-pin connector
JU1, JU2	2	2-pin headers
R1–R9	9	0 $\Omega$ $\pm 5\%$ resistors (0402)
R10, R11	2	100k $\Omega$ $\pm 5\%$ resistors (0603)
TP1–TP6	0	Not installed, test points
TP7, TP8	2	Black PCB test points
U1	1	MAX13035EETE+ (16-pin TQFN)
U2	1	$\pm 15$ kV ESD-protection array IC (6-pin TQFN-EP-6) Maxim MAX3202EETT+ (Top Mark: ADQ)
—	2	Shunts (JU1, JU2)
—	1	PCB: MAX13035E Evaluation Kit

### Features

- Supply Voltage Ranges
  - $V_L$ : 1.62V to 3.2V
  - $V_{CC}$ : 2.2V to 3.6V
- $\pm 15$ kV ESD Protection on I/O  $V_{CC}$  Lines
- SD Memory Card and General-Purpose Interface Connections
- 100Mbps Guaranteed Data Rates
- Fully Assembled and Tested

### Ordering Information

PART	TEMP RANGE	IC PACKAGE
MAX13035EEVKIT#	0°C to +70°C*	16 UCSP

#Denotes RoHS compliant EV kit.

\*This limited temperature range applies to the EV kit PCB only. The MAX13035E IC temperature range is -40°C to +85°C.

### Component Supplier

SUPPLIER	WEBSITE	WEBSITE
Murata Mfg. Co., Ltd.	770-436-1300	www.murata.com

**Note:** Indicate that you are using the MAX13035E when contacting this component supplier.

## Quick Start

### Recommended Equipment

- 2VDC power supply
- 3VDC power supply
- Logic function generator
- Oscilloscope

### Procedure

The MAX13035E EV kit is fully assembled and tested. Follow the steps below to verify board operation. **Caution: Do not turn on the power supply until all connections are completed.**

- 1) Verify that shunts are not installed on jumpers JU1 (card detect pulled high) and JU2 (write protect pulled high).
- 2) Set the logic function generator to produce a 1MHz, 2V<sub>P-P</sub>, 1V offset square wave. Disable the logic function generator output. Terminate the function generator as necessary.
- 3) Connect the positive terminal of the 2V supply to the VL PCB pad, and the ground terminal to the GND PCB pad.
- 4) Connect the positive terminal of the 3V supply to the VCC PCB pad, and the ground terminal to the GND PCB pad.
- 5) Connect the logic function generator to pin 8 of header J1 and the ground lead to pin 7 of header J1.
- 6) Connect the oscilloscope to test point TP1. Use test point TP8 as a ground reference for the oscilloscope.
- 7) Enable the power supplies and the logic function generator output.
- 8) Using the oscilloscope, verify that TP1 shows a 1MHz, 3V<sub>P-P</sub> square wave.

**Note:** All odd-number pins of header J1 are connected to GND. See Table 1 for even-number pins' signals.

**Table 1. I/O Interface Header J1 Pinout**

J1 PIN*	EV KIT SIGNAL
2	I/O V <sub>L</sub> 3
4	I/O V <sub>L</sub> 2
6	V <sub>L</sub>
8	I/O V <sub>L</sub> 1
10	V <sub>CC</sub>
12	CLK_V <sub>L</sub>
14	CLK_RET
16	I/O V <sub>L</sub> 5
18	I/O V <sub>L</sub> 4
20	CD
22	WP

\*All odd pins are connected to ground (GND).

## Detailed Description

The MAX13035E EV kit circuit demonstrates the MAX13035E 6-channel, bidirectional logic-level translator. The EV kit features an SD memory card interface, input/output (I/O) test points (TP1–TP6), GND test points (TP7, TP8), and header J1 for general-purpose interfacing. The MAX13035E guarantees data rates up to 100Mbps and demonstrates the MAX13035E ±15kV ESD protection. The MAX13035E translates between V<sub>L</sub> and V<sub>CC</sub> logic levels. The V<sub>L</sub> supply input range is 1.62V to 3.2V, while the V<sub>CC</sub> supply input range is 2.2V to 3.6V. V<sub>CC</sub> must be set higher than V<sub>L</sub>.

The MAX13035E EV kit circuit features I/O traces of matched length (within 30 mils) to maintain propagation-time uniformity. Jumpers JU1 and JU2 set the status signals for card detect (CD) and write protect (WP), respectively. CD and WP are ESD-protected to ±15kV by a MAX3202E IC (U2).

### I/O Interface Header J1

Header J1 provides access to the circuit's V<sub>L</sub> logic-level I/O signals, power input lines, and status signals (CD and WP). Use either the PCB pads for V<sub>CC</sub> and V<sub>L</sub>, or the corresponding pins on J1 (pins 10 and 6, respectively) to power the kit. Use the CD and WP pins on J1 to monitor the card-detect and write-protect status signals. I/O V<sub>L</sub>1–I/O V<sub>L</sub>5 and CLK\_V<sub>L</sub> are the EV kit's V<sub>L</sub> referenced logic signals. CLK\_RET is the returned signal at a clock applied to CLK\_V<sub>L</sub>. CLK\_RET is referenced to V<sub>L</sub>.

**V<sub>CC</sub> Logic-Level I/O**

The EV kit provides an SD memory card interface, as well as general-purpose interface test points (TP1–TP6) for the V<sub>CC</sub> logic-level I/O signals. Use test points TP7 and TP8 as the signals’ ground reference. Use connector J2 with standard SD pinout for interfacing with an SD memory card. CD and WP signals are actuated within connector J2, see the *CD/WP Status Signals* section in this document. See Table 2 for V<sub>CC</sub> I/O signal connections.

**CD/WP Status Signals**

Connector J2 provides access to the active-low status signals, CD and WP. Resistors R10 and R11 are the pullup resistors for CD and WP. Upon inserting an SD card into J2, the CD signal is driven to ground. If the SD card inserted into J2 is write-protected, the WP signal is driven to ground. Jumpers JU1 and JU2 are provided to set the CD and WP signals. See Tables 3 and 4 for jumpers JU1 and JU2 configurations.

**Table 2. SD Card Connector J2 Pinout**

J2 PIN (SD)	EV KIT FUNCTION	TEST POINT	STANDARD SD FUNCTION
9	I/O V <sub>CC</sub> 1	TP1	DAT2
1	I/O V <sub>CC</sub> 3	TP3	CD/DAT3
2	I/O V <sub>CC</sub> 2	TP2	CMD
3	GND	—	V <sub>SS</sub>
4	V <sub>CC</sub>	—	V <sub>DD</sub>
5	CLK_V <sub>CC</sub>	TP6	CLK
6	GND	—	V <sub>SS</sub>
7	I/O V <sub>CC</sub> 4	TP4	DAT0
8	I/O V <sub>CC</sub> 5	TP5	DAT1
10	CD	—	CD
11	WP	—	WP

**Table 3. Write-Protect Status Signal (Jumper JU1)**

SHUNT POSITION	WRITE PROTECT (WP)	EV KIT FUNCTION
Installed	Connected to GND	WP set low
Not installed	Connected to VCC through resistor R10	WP set high

**Table 4. Card-Detect Status Signal (Jumper JU2)**

SHUNT POSITION	WRITE PROTECT (WP)	EV KIT FUNCTION
Installed	Connected to GND	CD set low
Not installed	Connected to VCC through resistor R11	CD set high

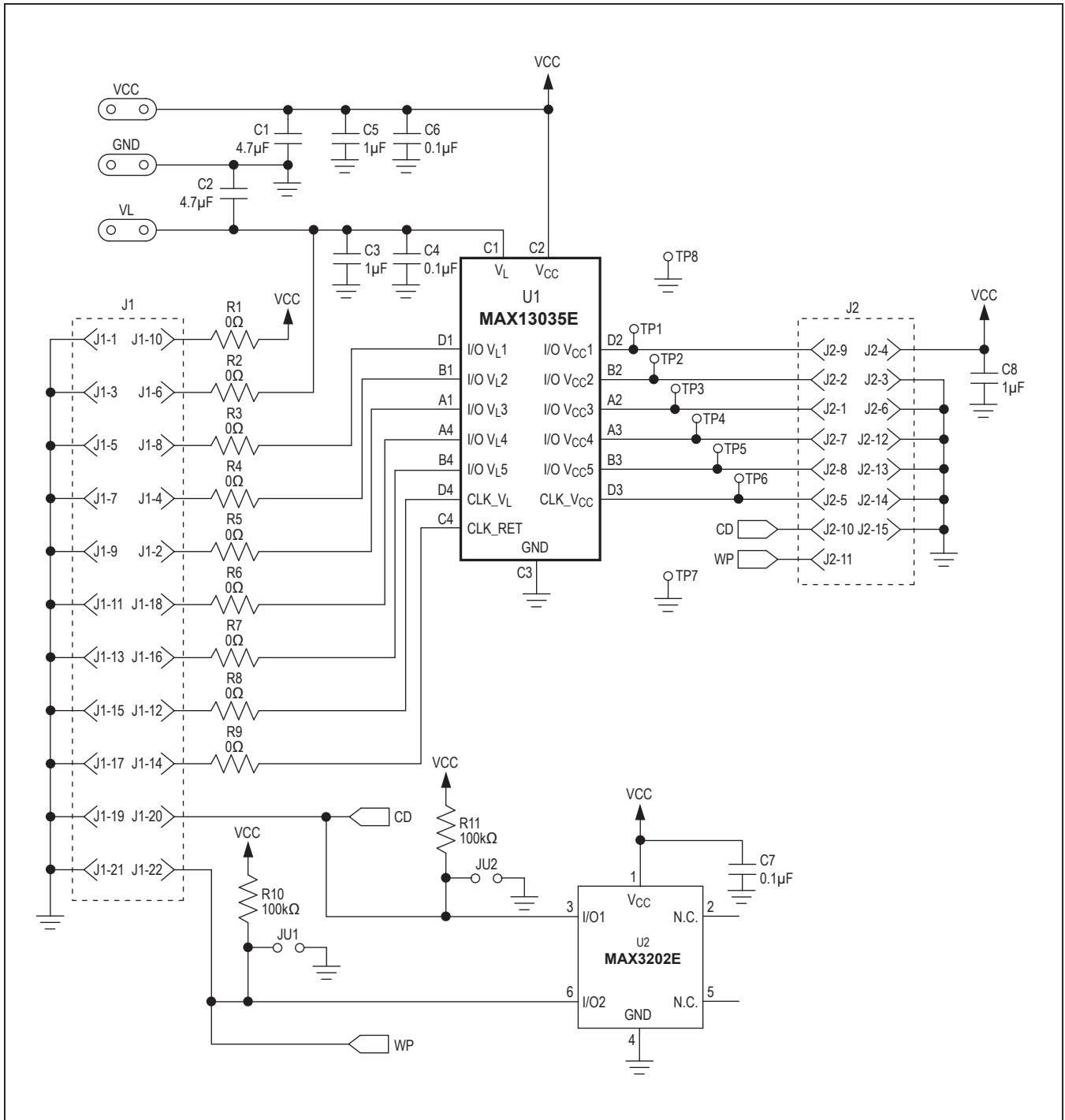

Figure 1. MAX13035E EV Kit Schematic

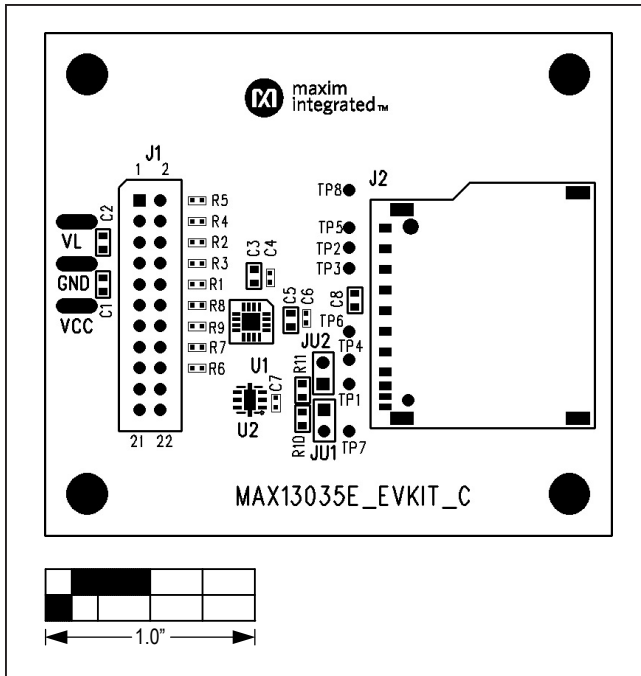

Figure 2. MAX13035E EV Kit Component Placement Guide—Component Side

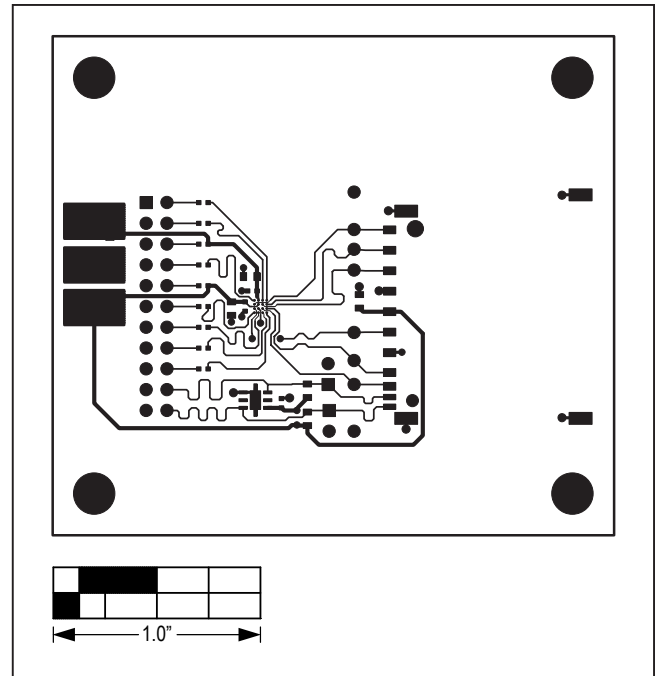

Figure 3. MAX13035E EV Kit PCB Layout—Component Side

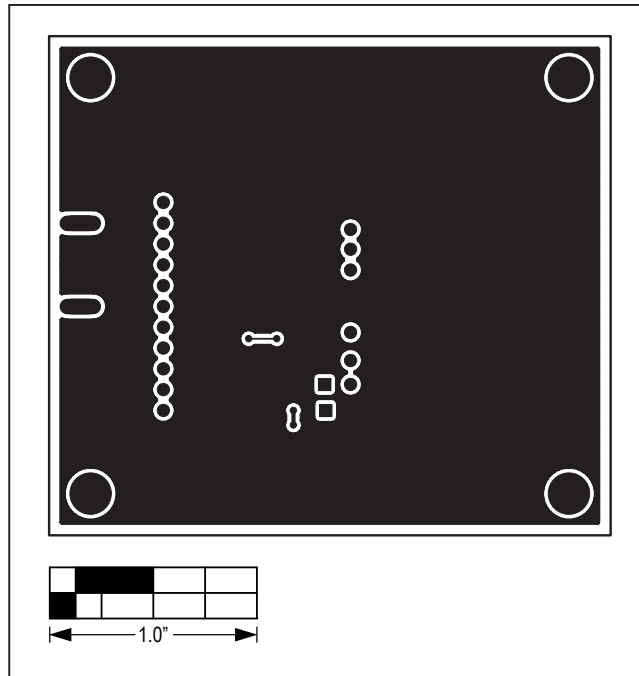

Figure 4. MAX13035E EV Kit PCB Layout—Solder Side

## Revision History

REVISION NUMBER	REVISION DATE	DESCRIPTION	PAGES CHANGED
0	5/07	Initial Release	—
1	10/20	Updated <i>Ordering Information</i> and Figure 2	1, 5
2	12/20	Updated <i>Component List</i>	1

For pricing, delivery, and ordering information, please visit Maxim Integrated's online storefront at <https://www.maximintegrated.com/en/storefront/storefront.html>.

*Maxim Integrated cannot assume responsibility for use of any circuitry other than circuitry entirely embodied in a Maxim Integrated product. No circuit patent licenses are implied. Maxim Integrated reserves the right to change the circuitry and specifications without notice at any time.*

## X-ON Electronics

Largest Supplier of Electrical and Electronic Components

*Click to view similar products for [Interface Development Tools](#) category:*

*Click to view products by [Maxim](#) manufacturer:*

Other Similar products are found below :

[ADP5585CP-EVALZ](#) [CHA2066-99F](#) [AS8650-DB](#) [MLX80104 TESTINTERFACE](#) [416100120-3](#) [XR18910ILEVB](#) [XR21B1421IL28-0A-EVB](#) [TW-DONGLE-USB](#) [EVAL-ADM2491EEBZ](#) [MAXREFDES23DB#](#) [MAX13235EEVKIT](#) [DFR0257](#) [XR22404CG28EVB](#) [ZLR964122L](#) [ZLR88822L](#) [EVK-U23-01S](#) [EVK-W262U-00](#) [DC327A](#) [PIM511](#) [PIM536](#) [PIM517](#) [DEV-17512](#) [STR-FUSB3307MPX-PPS-GEVK](#) [MAXREFDES177#](#) [EVAL-ADM2567EEBZ](#) [ZSSC3240KIT](#) [MAX9121EVKIT](#) [PIM532](#) [ZSC31010KITV2P1](#) [UMFT4233HPEV](#) [LVDS-18B-EVK](#) [XR20M1170G16-0B-EB](#) [XR20M1170G24-0B-EB](#) [XR20M1172G28-0A-EB](#) [XR20M1172G28-0B-EB](#) [SI871XSOIC8-KIT](#) [1764](#) [1833](#) [1862](#) [EVB-USB82514](#) [ATA6628-EK](#) [ATA6631-EK](#) [EVAL-CN0313-SDPZ](#) [2264](#) [MCP23X17EV](#) [PS081-EVA-HR MODULE](#) [237](#) [SMA2RJ45EVK/NOPB](#) [FR12-0002](#) [MAFR-000455-001](#)