



+5V Multiprotocol, Pin-Selectable Cable Terminator

MAX13174E

General Description

The MAX13174E contains six pin-selectable, multiprotocol cable termination networks. Each network is capable of terminating V.11 (RS-422, RS-530, RS-530A, RS-449, V.36, and X.21) with a 100Ω differential load, V.35 with a T-network load, or V.28 (RS-232) and V.10 (RS-423) with an open-circuit load for use with transceivers having on-chip termination. The termination protocol can be selected by the serial interface cable wiring or by pin control. The MAX13174E replaces discrete resistor termination networks and expensive relays required for multiprotocol termination, saving space and cost.

The MAX13174E terminator is ideal to form a complete +5V cable- or pin-selectable multiprotocol DCE/DTE interface port when used with the MAX13170E and MAX13172E transceiver ICs. The MAX13174E terminator can use the VEE power generated by the MAX13170E charge pump, simplifying system design. The MAX13174E/MAX13170E/MAX13172E are pin-for-pin compatible with the MXL1344A/MXL1543/MXL1544/MAX3175.

The MAX13174E is available in a 24-pin SSOP package and is specified for the 0°C to +70°C commercial temperature range.

Features

- ◆ Supports V.11 and V.35 Termination
- ◆ Pin-Selectable Termination
- ◆ Pin-Selectable DCE/DTE Support
- ◆ Replaces Discrete Resistor Termination Networks and Expensive Relays
- ◆ Available in 24-Pin SSOP Package
- ◆ Certified TBR-1 and TBR-2-Compliant Chipset (NET1 and NET2)—Pending Completion of Testing

Applications

- Data Networking
- PCI Cards
- CSU and DSU
- Telecommunication Equipment
- Data Routers
- Data Switches

Ordering Information

PART	TEMP RANGE	PIN-PACKAGE
MAX13174ECAG+	0°C to +70°C	24 SSOP

+ Denotes a lead(Pb)-free/RoHS-compliant package.

Pin Configuration appears at end of data sheet.

Typical Operating Circuit

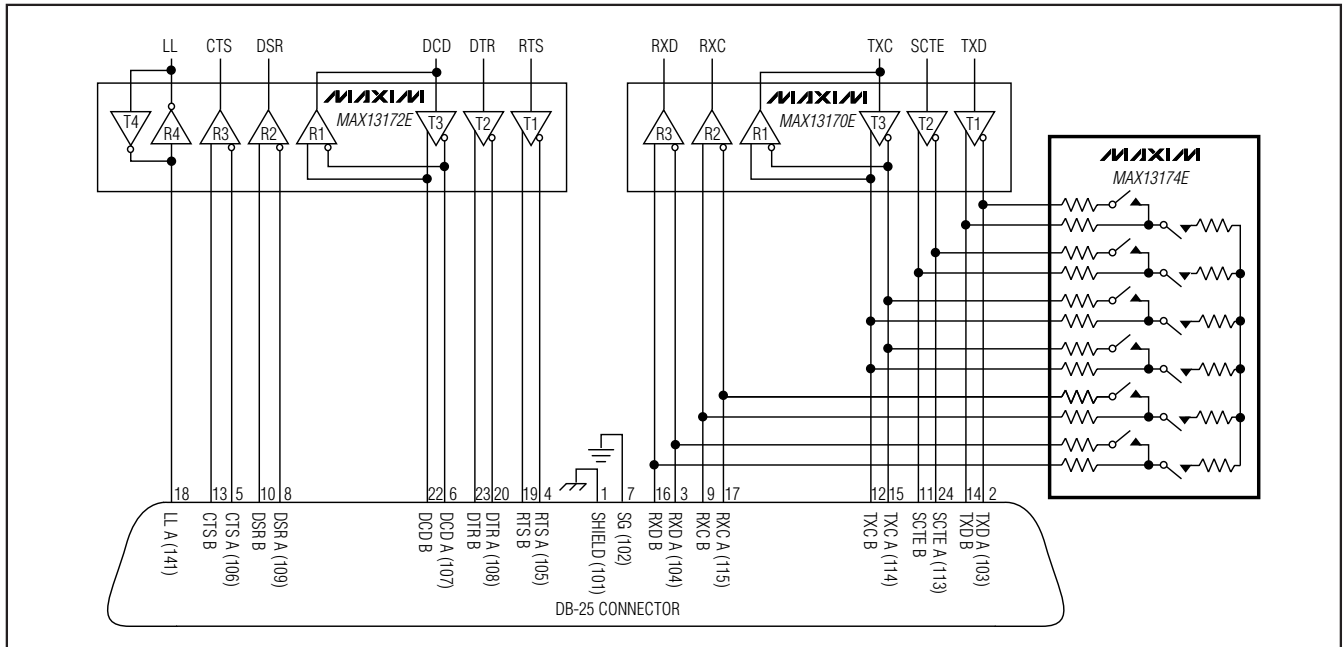

+5V Multiprotocol, Pin-Selectable Cable Terminator

ABSOLUTE MAXIMUM RATINGS

(All voltages to GND, unless otherwise noted.)

Supply Voltages

V _{CC}	-0.3V to +6V
V _{EE}	+0.3V to -7.1V

Logic-Input Voltages

M0, M1, M2, DCE/DTE, LATCH	-0.3V to +6V
----------------------------	--------------

Termination Network Inputs

R _A , R _B , R _C	-15V to +15V
R _A to R _B (high-impedance state)	±14V
R _A to R _B	±6V
R _C to R _B (high-impedance state)	±3V

R _A to R _C	±3V
R _C to R _A (high-impedance state)	±14V
Continuous Power Dissipation (T _A = +70°C)	
24-Pin SSOP (derate 14.9mW/°C above +70°C)	1196mW
Junction-to-Case Thermal Resistance (θ _{JC}) (Note 1)	
24-Pin SSOP	24.6°C/W
Junction-to-Ambient Thermal Resistance (θ _{JA}) (Note 1)	
24-Pin SSOP	66.9°C/W
Operating Temperature Range	0°C to +70°C
Junction Temperature	+150°C
Storage Temperature Range	-65°C to +150°C
Lead Temperature (soldering, 10s)	+300°C

Note 1: Package thermal resistances were obtained using the method described in JEDEC specification JESD51-7, using a four-layer board. For detailed information on package thermal considerations, refer to www.maxim-ic.com/thermal-tutorial.

Stresses beyond those listed under "Absolute Maximum Ratings" may cause permanent damage to the device. These are stress ratings only, and functional operation of the device at these or any other conditions beyond those indicated in the operational sections of the specifications is not implied. Exposure to absolute maximum rating conditions for extended periods may affect device reliability.

ELECTRICAL CHARACTERISTICS

(V_{CC} = +4.5V to +5.5V, V_{EE} = -4V to -7.1V, T_A = 0°C to +70°C, unless otherwise noted. Typical values are at T_A = +25°C, V_{CC} = +5V, V_{EE} = -5V, unless otherwise noted.) (Note 2)

PARAMETER	SYMBOL	CONDITIONS	MIN	TYP	MAX	UNITS
V _{CC} Operating Range	V _{CC}		4.5	5	5.5	V
V _{EE} Operating Range	V _{EE}		-7.1	-5	-4	V
V _{CC} POR Rising Threshold			1	1.88	2.75	V
V _{CC} Supply Current	I _{CC}	All inputs connected to GND or V _{CC} , except no-cable mode		2.2	6.15	mA
	I _{CC_NO CAB}	V _{EE} = 0V, M[x] = 1111 (Note 3)		1.34	2.85	
V _{EE} Supply Current	I _{EE}	All inputs connected to GND or V _{CC} , except no-cable mode	-3.5	-1		mA
TERMINATOR INPUTS						
Differential-Mode Impedance V.35 Mode		-2V ≤ V _{CM} ≤ +2V, all channels (Figure 1)	90	104	110	Ω
Common-Mode Impedance V.35 Mode		-2V ≤ V _{CM} ≤ +2V, all channels (Figure 2)	135	153	165	Ω
Differential-Mode Impedance V.11 Mode		-7V ≤ V _{CM} ≤ +7V, all channels, except no-cable mode (Figure 1)	100	104	110	Ω
		-7V ≤ V _{CM} ≤ +7V, all channels, no-cable mode, V _{EE} = 0V, V _{AB} ≤ 2V (Figure 1)		115		
High-Impedance Leakage Current	I _Z	-15V ≤ V _{R_A} ≤ +15V	-50		+50	μA
Differential Path Enable Time				50		μs
Differential Path Disable Time				300		μs
Common-Mode Path Enable Time				12		μs
Common-Mode Path Disable				2		μs

+5V Multiprotocol, Pin-Selectable Cable Terminator

ELECTRICAL CHARACTERISTICS (continued)

($V_{CC} = +4.5V$ to $+5.5V$, $V_{EE} = -4V$ to $-7.1V$, $T_A = 0^\circ C$ to $+70^\circ C$, unless otherwise noted. Typical values are at $T_A = +25^\circ C$, $V_{CC} = +5V$, $V_{EE} = -5V$, unless otherwise noted.) (Note 2)

PARAMETER	SYMBOL	CONDITIONS	MIN	TYP	MAX	UNITS
LOGIC INPUTS (M0, M1, M2, LATCH, DCE/DTE)						
Input High Voltage	V_{IH}		0.66 x V_{CC}			V
Input Low Voltage	V_{IL}			0.33 x V_{CC}		V
Logic Input Current	I_{IN}	$V_{IN} = V_{CC}$ or GND	-1		+1	μA
ESD PROTECTION						
R_A, R_B to GND		Human Body Model			± 15	kV
		Air Gap Discharge IEC 61000-4-2			± 10	
		Contact Discharge IEC 61000-4-2			± 6	
All Other Pins		Human Body Model			± 2	kV

Note 2: All parameters tested at a single temperature. Specifications over temperature are guaranteed by design.

Note 3: M[x] is the input bus DCE/DTE, M2, M1, M0.

Typical Operating Characteristics

($V_{CC} = +5V$, $V_{EE} = -5V$, $T_A = +25^\circ C$, unless otherwise noted.)

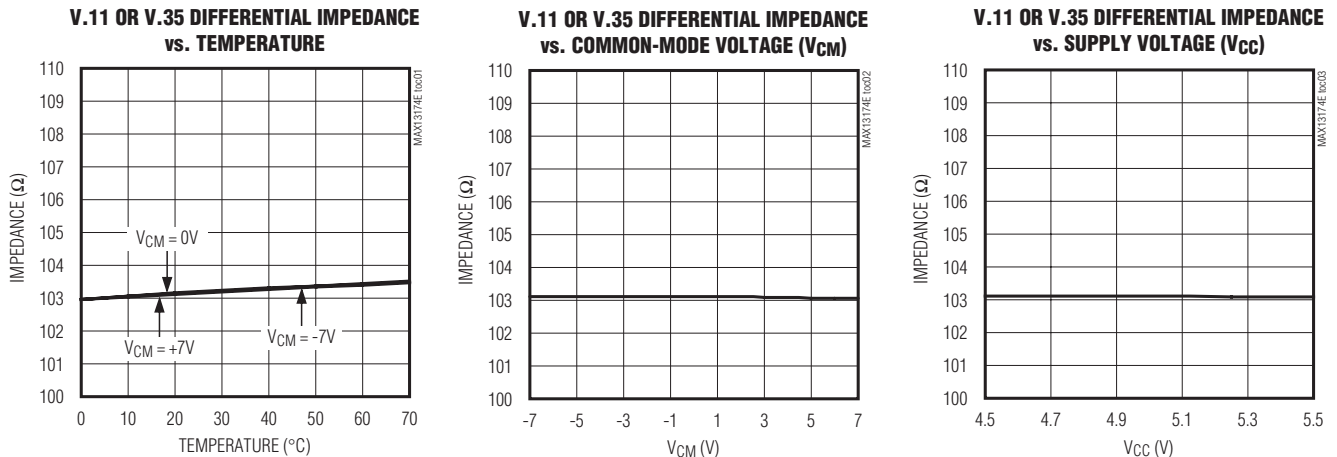

+5V Multiprotocol, Pin-Selectable Cable Terminator

Typical Operating Characteristics (continued)

($V_{CC} = +5V$, $V_{EE} = -5V$, $T_A = +25^\circ C$, unless otherwise noted.)

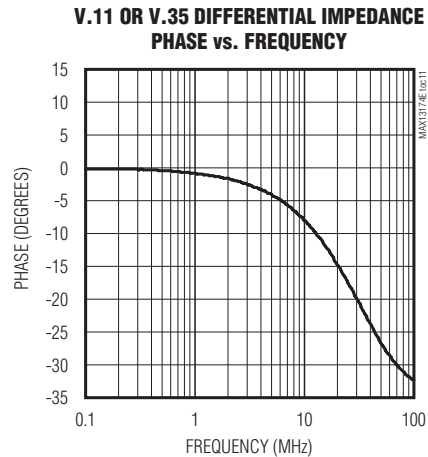
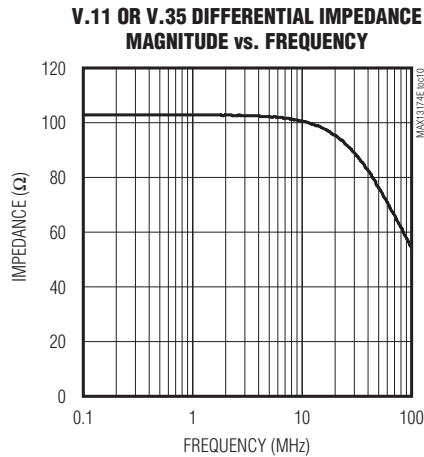
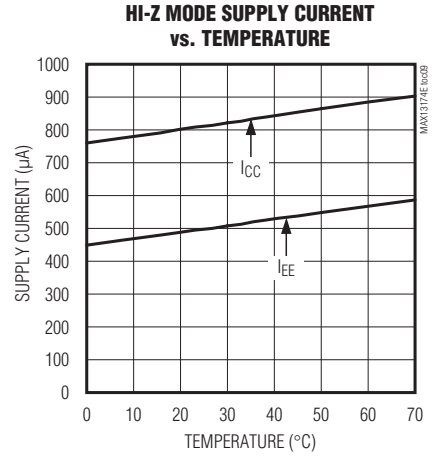
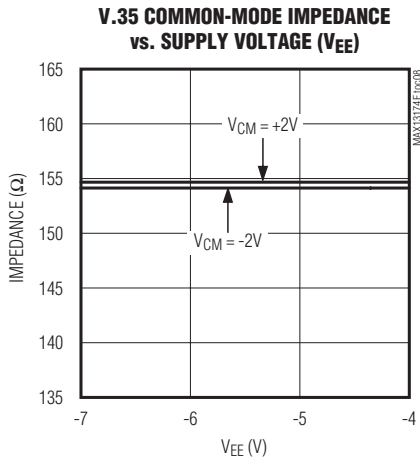
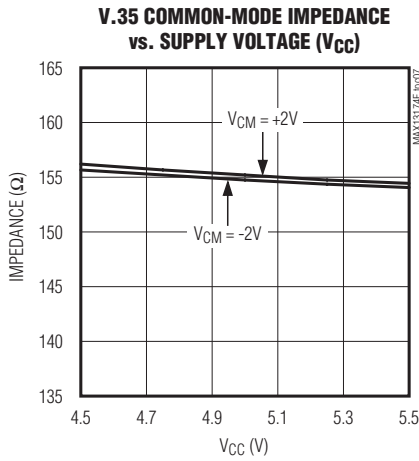
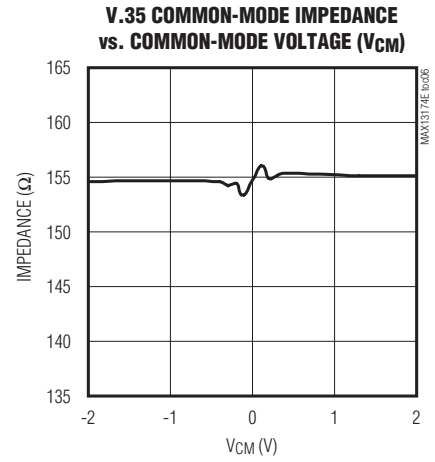
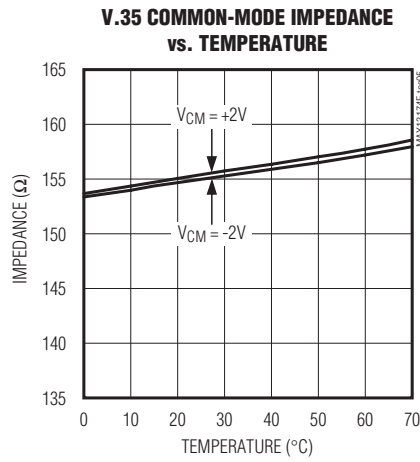
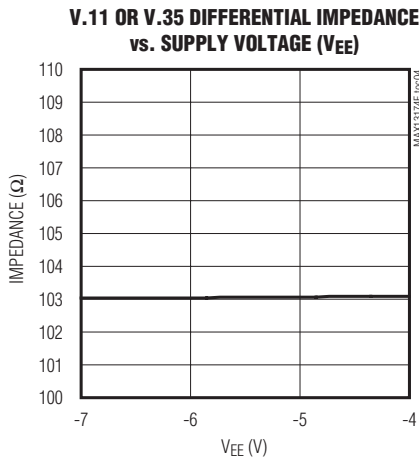

+5V Multiprotocol, Pin-Selectable Cable Terminator

MAX13174E

Pin Description

PIN	NAME	FUNCTION
1	M0	Mode-Select Input (Table 1)
2	V _{EE}	Negative Supply Voltage (typically connected to V _{EE} of MAX13170E). Bypass to GND with a 0.1μF capacitor.
3	R1C	Load 1, Center Tap
4	R1B	Load 1, Node B
5	R1A	Load 1, Node A
6	R2A	Load 2, Node A
7	R2B	Load 2, Node B
8	R2C	Load 2, Center Tap
9	R3A	Load 3, Node A
10	R3B	Load 3, Node B
11	R3C	Load 3, Center Tap
12, 13	GND	Ground
14	V _{CC}	+5V Supply Voltage. Bypass to GND with a 0.1μF capacitor.
15	R4B	Load 4, Node B
16	R4A	Load 4, Node A
17	R5B	Load 5, Node B
18	R5A	Load 5, Node A
19	R6A	Load 6, Node A
20	R6B	Load 6, Node B
21	$\overline{\text{LATCH}}$	Latch Signal Input. When $\overline{\text{LATCH}}$ is low, the input latches are transparent. When $\overline{\text{LATCH}}$ is high, the data at the mode-select inputs are latched.
22	DCE/ $\overline{\text{DTE}}$	DCE/ $\overline{\text{DTE}}$ Mode-Select Input (Table 1)
23	M2	Mode-Select Input (Table 1)
24	M1	Mode-Select Input (Table 1)

Detailed Description

The MAX13174E contains six pin-selectable multiprotocol cable termination networks (Figure 3). Each network is capable of terminating V.11 (RS-422, RS-530, RS-530A, RS-449, V.36, and X.21) with a 100Ω differential load, V.35 with a T-network load, or V.28 (RS-232) and V.10 (RS-423) with an open-circuit load for use with transceivers that have on-chip termination. The termination protocol can be selected by the serial interface cable wiring or by pin control. The MAX13174E replaces discrete resistor termination networks and expensive relays required for multiprotocol termination, saving space and cost.

The MAX13174E terminator is designed to form a complete +5V cable- or pin-selectable multiprotocol DCE/DTE interface port when used with the MAX13170E and MAX13172E transceivers. The MAX13174E terminator

can use the V_{EE} power generated by the MAX13170E charge pump, simplifying system design. The MAX13174E/MAX13170E/MAX13172E are functionally compatible with the MXL1344A/MXL1543/MXL1544/MAX3175.

Termination Modes

The termination networks in the MAX13174E can be set to one of three modes: V.11, V.35, or high impedance. As shown in Figure 4, in V.11 mode, switch S1 is closed and switch S2 is open, presenting 104Ω across terminals A and B. In V.35 mode, switches S1 and S2 are both closed, presenting a T-network with 104Ω differential impedance and 153Ω common-mode impedance. In high-impedance mode, switches S1 and S2 are both open, presenting a high impedance across terminals A and B suitable for V.28 and V.10 modes.

+5V Multiprotocol, Pin-Selectable Cable Terminator

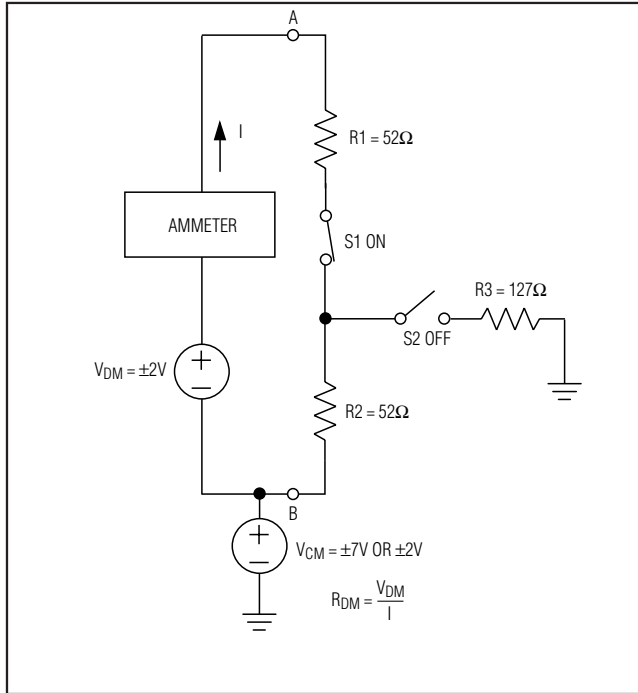

Figure 1. V.11 or V.35 Differential Impedance Measurement

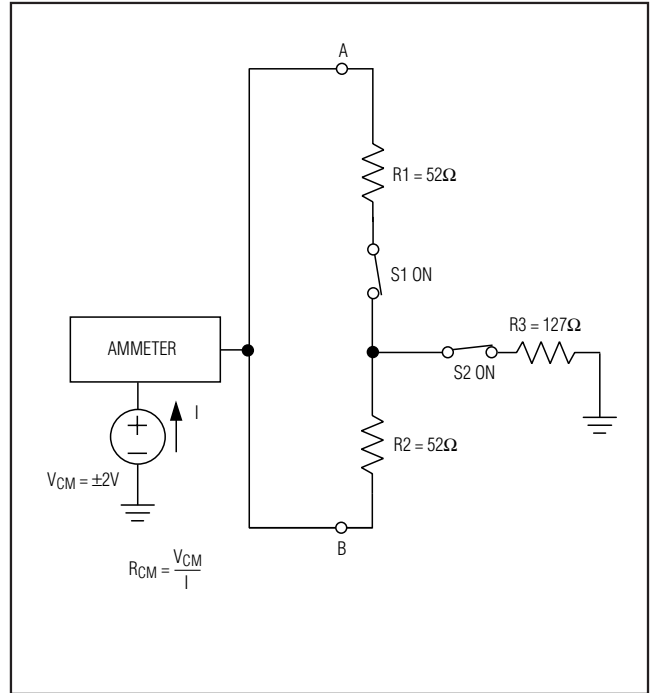

Figure 2. V.35 Common-Mode Impedance Measurement

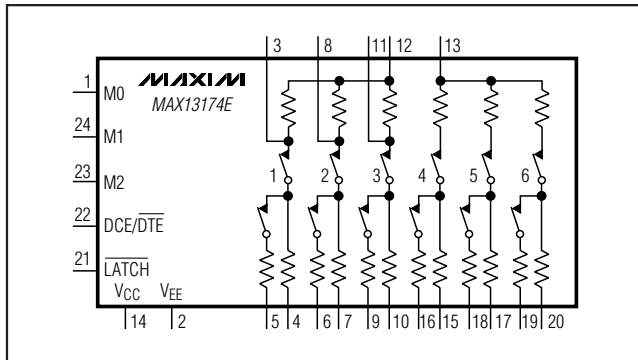

Figure 3. Block Diagram

The state of the MAX13174E's mode-select pins—M0, M1, M2, and DCE/DTE—determines the mode of each of the six termination networks. Table 1 shows a cross-reference of termination mode and select pin state for each of the six termination networks within the MAX13174E.

No-Cable Mode

The MAX13174E enters no-cable mode when the mode-select inputs—M0, M1, and M2—are connected high. In no-cable mode, all six termination networks are placed in V.11 mode, with S1 closed and S2 open (Figure 4).

Applications Information

Older multiprotocol interface termination circuits have been constructed using expensive relays with discrete resistors, custom cables with built-in termination, or complex circuit-board configurations to route signals to the correct termination. The MAX13174E provides a simple solution to this termination problem. All required termination configurations are easily cable- or pin-selectable using the four mode-control input pins (M0, M1, M2, and DCE/DTE).

Using the MAX13174E in a Multiprotocol Serial Interface

The MAX13174E terminator is designed to form a complete +5V cable- or pin-selectable multiprotocol DCE/DTE interface port when used with the MAX13170E/MAX13172E differential drivers/receivers. The MAX13174E terminator is designed to use the VEE power generated by the MAX13171E's charge pump and meets all data sheet specifications when connected as illustrated in Figure 5. The mode-selection tables of all three devices are identical, allowing the M0, M1, M2, and DCE/DTE pins of each device to be connected to a single 4-wire control bus. The MAX13170E and MAX13172E provide internal pullups for the four lines,

+5V Multiprotocol, Pin-Selectable Cable Terminator

Table 1. Termination Mode Select Table

PROTOCOL	DCE/DTE	M2	M1	M0	R1	R2	R3	R4	R5	R6
V.10/RS-423	0	0	0	0	Z	Z	Z	Z	Z	Z
RS-530A	0	0	0	1	Z	Z	Z	V.11	V.11	V.11
RS-530	0	0	1	0	Z	Z	Z	V.11	V.11	V.11
X.21	0	0	1	1	Z	Z	Z	V.11	V.11	V.11
V.35	0	1	0	0	V.35	V.35	Z	V.35	V.35	V.35
RS-449/V.36	0	1	0	1	Z	Z	Z	V.11	V.11	V.11
V.28/RS-232	0	1	1	0	Z	Z	Z	Z	Z	Z
No Cable	0	1	1	1	V.11	V.11	V.11	V.11	V.11	V.11
V.10/RS-423	1	0	0	0	Z	Z	Z	Z	Z	Z
RS-530A	1	0	0	1	Z	Z	Z	Z	V.11	V.11
RS-530	1	0	1	0	Z	Z	Z	Z	V.11	V.11
X.21	1	0	1	1	Z	Z	Z	Z	V.11	V.11
V.35	1	1	0	0	V.35	V.35	V.35	Z	V.35	V.35
RS-449/V.36	1	1	0	1	Z	Z	Z	Z	V.11	V.11
V.28/RS-232	1	1	1	0	Z	Z	Z	Z	Z	Z
No Cable	1	1	1	1	V.11	V.11	V.11	V.11	V.11	V.11

Note: Z indicates high impedance, 1 = high, and 0 = low. Z, V.11, and V.35 refer to termination modes (Figure 4).

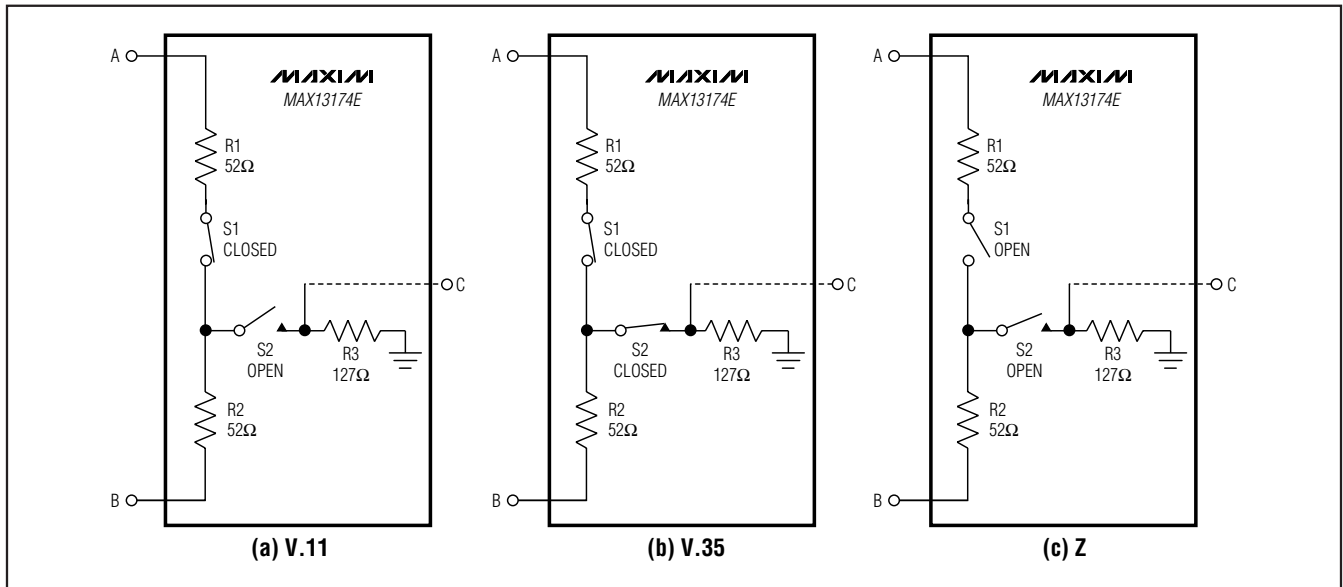

Figure 4. Termination Modes

forcing them to the logic-high state if they are not grounded. This allows interface-mode configuration by simply strapping the appropriate pins to ground in the interconnect cable.

V.11 Termination

A standard V.11 interface is shown in Figure 6. For high-speed data transmission, the V.11 specification recommends terminating the cable at the receiver with a 100Ω (min) resistor. The resistor, although not required, prevents reflections from corrupting transmitted data.

+5V Multiprotocol, Pin-Selectable Cable Terminator

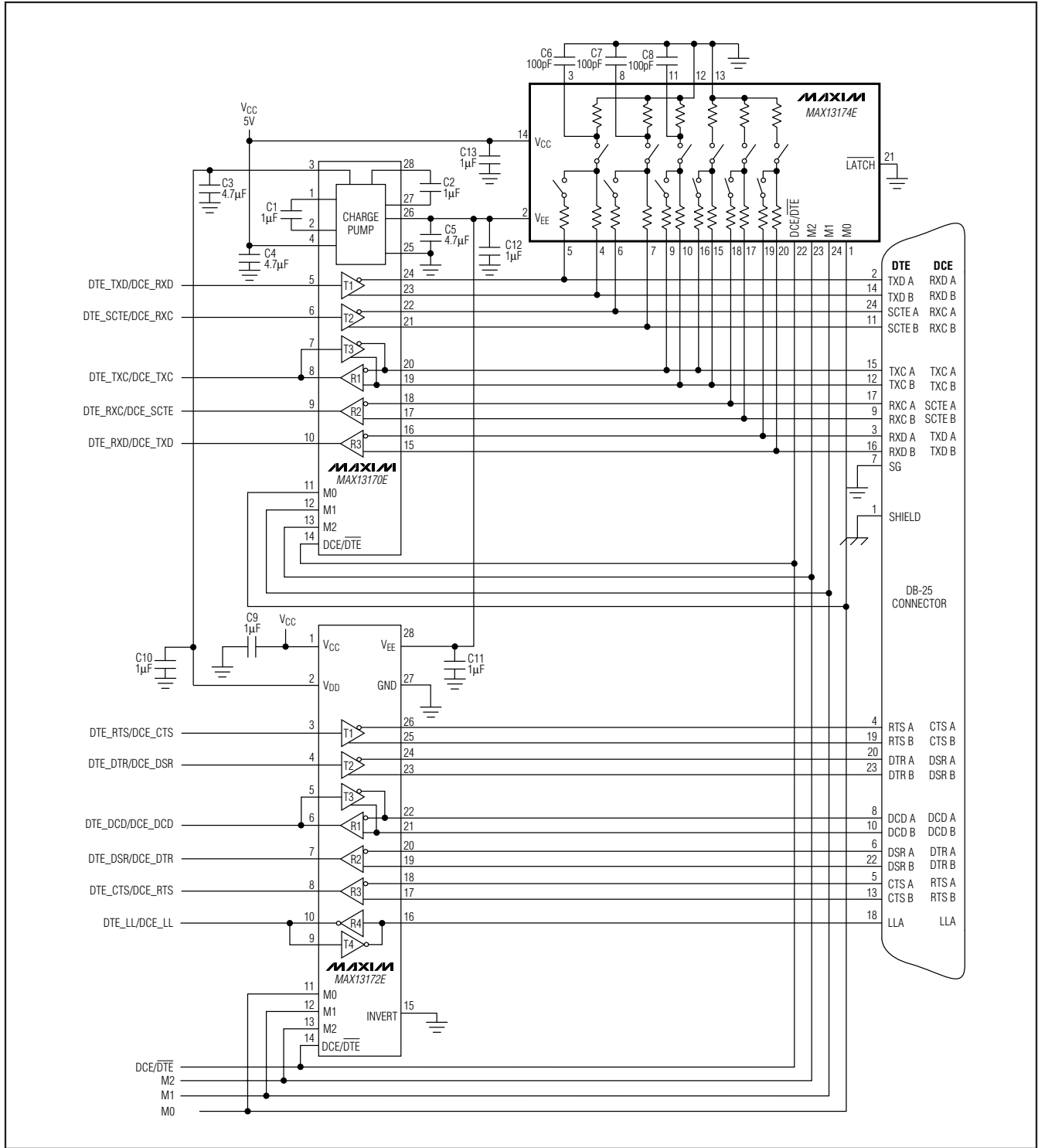

Figure 5. Multiprotocol DCE/DTE Port

+5V Multiprotocol, Pin-Selectable Cable Terminator

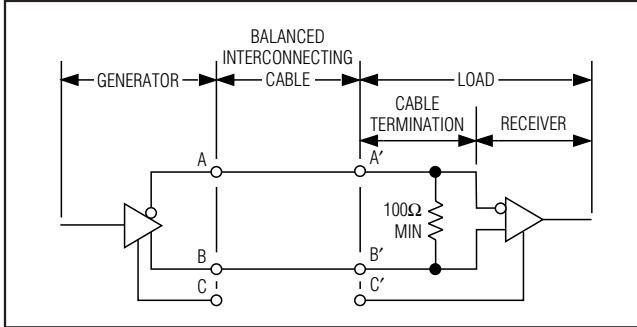

Figure 6. Typical V.11 Interface

In Figure 7, the MAX13174E is used to terminate the V.11 receiver on the MAX13170E. Internal to the MAX13174E, S1 is closed and S2 is open to present a 104Ω typical differential resistance and high-Z common-mode impedance. The MAX13170E's internal V.28 termination is disabled by opening S3.

The V.11 specification allows for signals with common-mode variations of ±7V and differential signal amplitudes from 2V to 6V. The MAX13174E maintains termination impedance between 100Ω and 110Ω over these conditions.

V.35 Termination

Figure 8 shows a standard V.35 interface. The generator and the load must both present a 100Ω ± 10Ω differential

impedance and a 150Ω ± 15Ω common-mode impedance. The V.35 driver generates a current output (±11mA, typ) that develops an output voltage between 440mV and 660mV across the load termination networks.

In Figure 9, the MAX13174E is used to implement the resistive T-network that is needed to properly terminate the V.35 receiver. Internal to the MAX13174E, S1 and S2 are closed to connect the T-network resistors to the circuit.

The V.35 specification allows for ±4V of ground difference between the V.35 generator and V.35 load. The MAX13174E maintains correct termination impedance over these conditions.

V.35 EMI reduction

For applications where EMI reduction is especially important, the MAX13174E termination networks provide a pin for shunting common-mode driver currents to GND. Mismatches between the driver A and B output propagation delays can create a common-mode disturbance on the cable. This common-mode energy can be shunted to GND by placing a 100pF capacitor to GND from the center tap of the T-network termination (R1C, R2C, and R3C as shown in Figure 5).

V.28 Termination

Most industry-standard V.28 receivers (including the MAX13170E and MAX13172E) do not require external termination because the receiver includes an internal 5kΩ termination resistor. When the MAX13174E is

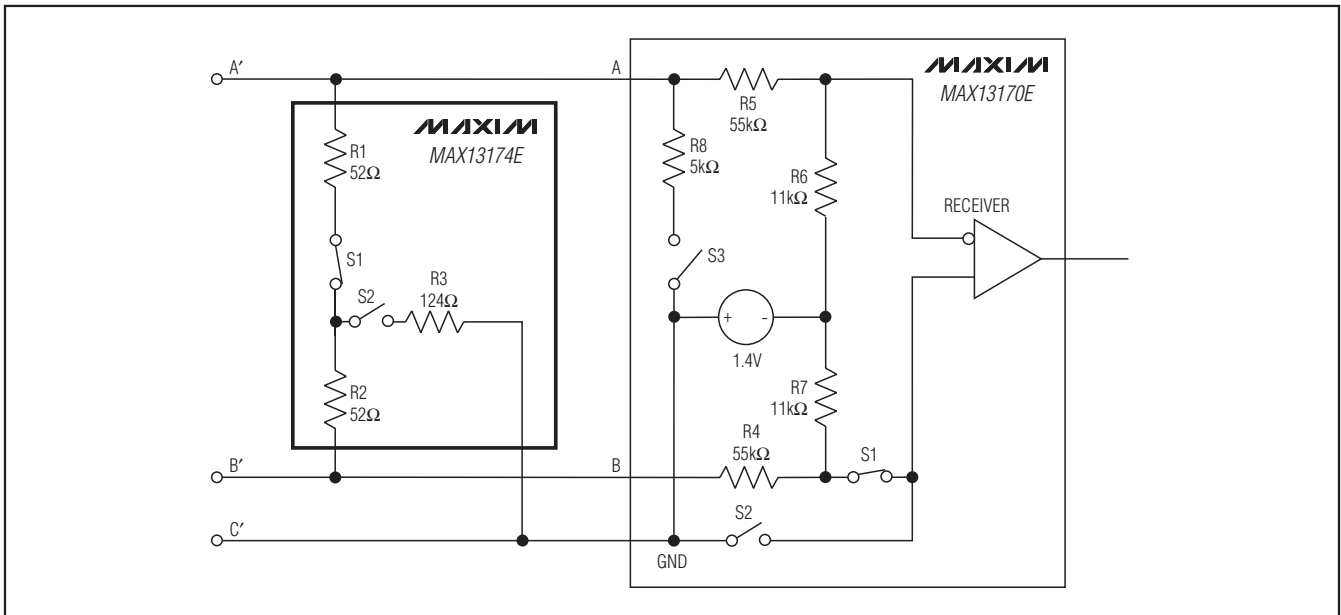

Figure 7. V.11 Termination and Internal Resistance Networks

+5V Multiprotocol, Pin-Selectable Cable Terminator

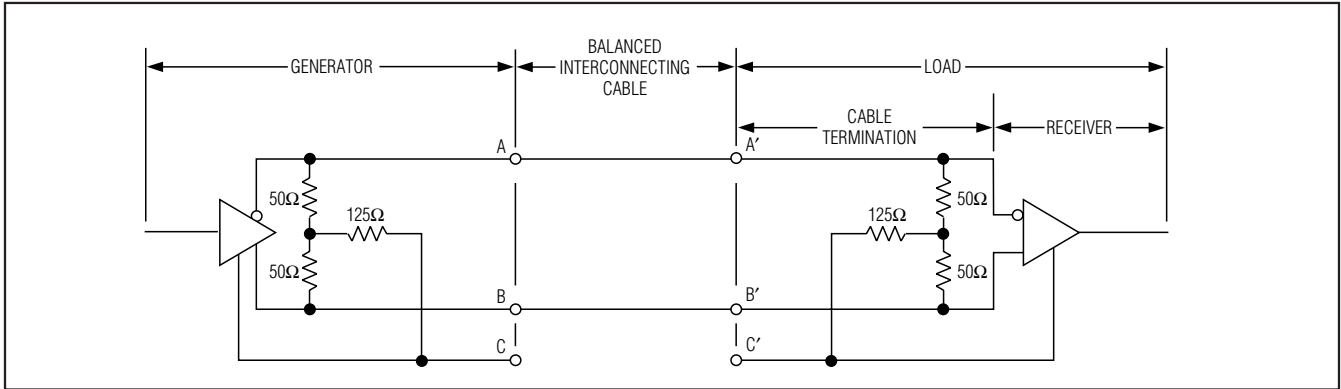

Figure 8. Typical V.35 Interface

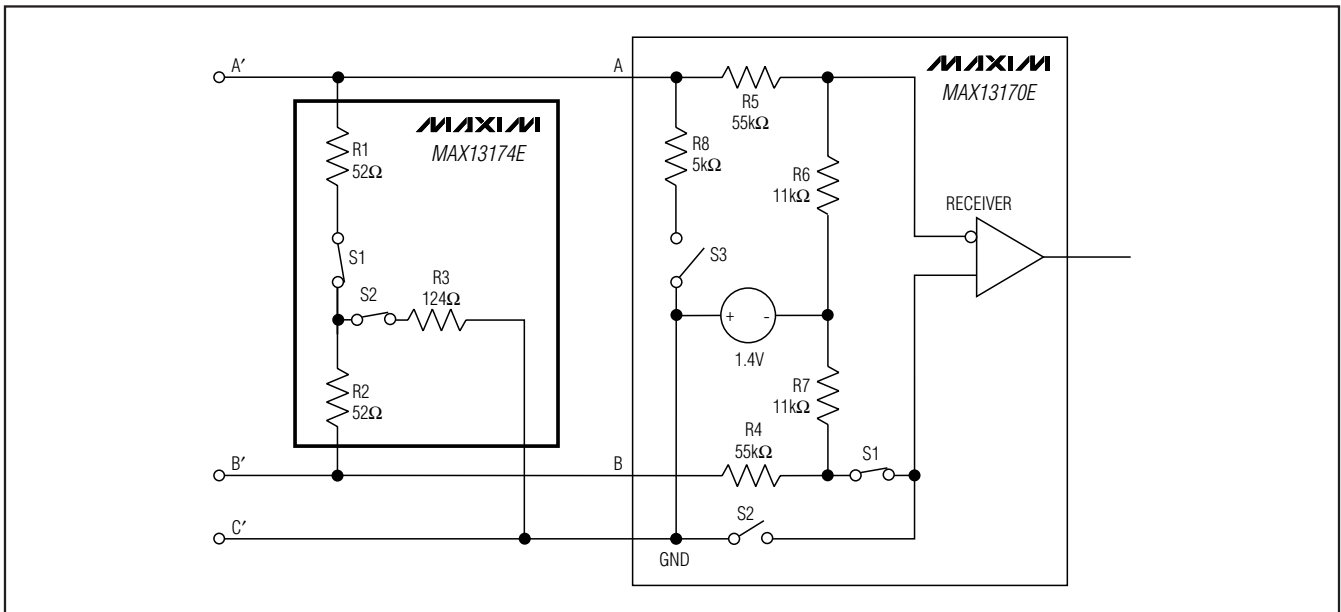

Figure 9. V.35 Termination and Internal Resistance Networks

placed in V.28 mode, all six of the termination networks are placed in a high-Z mode. In high-Z mode, the MAX13174E termination networks do not interfere with the MAX13170E's internal 5kΩ termination.

In Figure 10, the MAX13174E and MAX13170E are placed in V.28 mode. Switches S1 and S2 are opened on the MAX13174E to place the network in high-Z mode. Switch S3 is closed on the MAX13170E to enable the 5kΩ terminating resistor.

A Complete X.21 Interface

A complete DTE-to-DCE interface operating in X.21 mode is shown in Figure 11. The MAX13174E terminates the V.11 clock and data signals. The MAX13170E carries the clock and data signals, and the MAX13172E carries the control signals. The control signals generally do not require external termination.

ESD Protection

ESD-protection structures are incorporated on all pins to protect against electrostatic discharges encountered during handling and assembly. The differential resistors

+5V Multiprotocol, Pin-Selectable Cable Terminator

MAX13174E

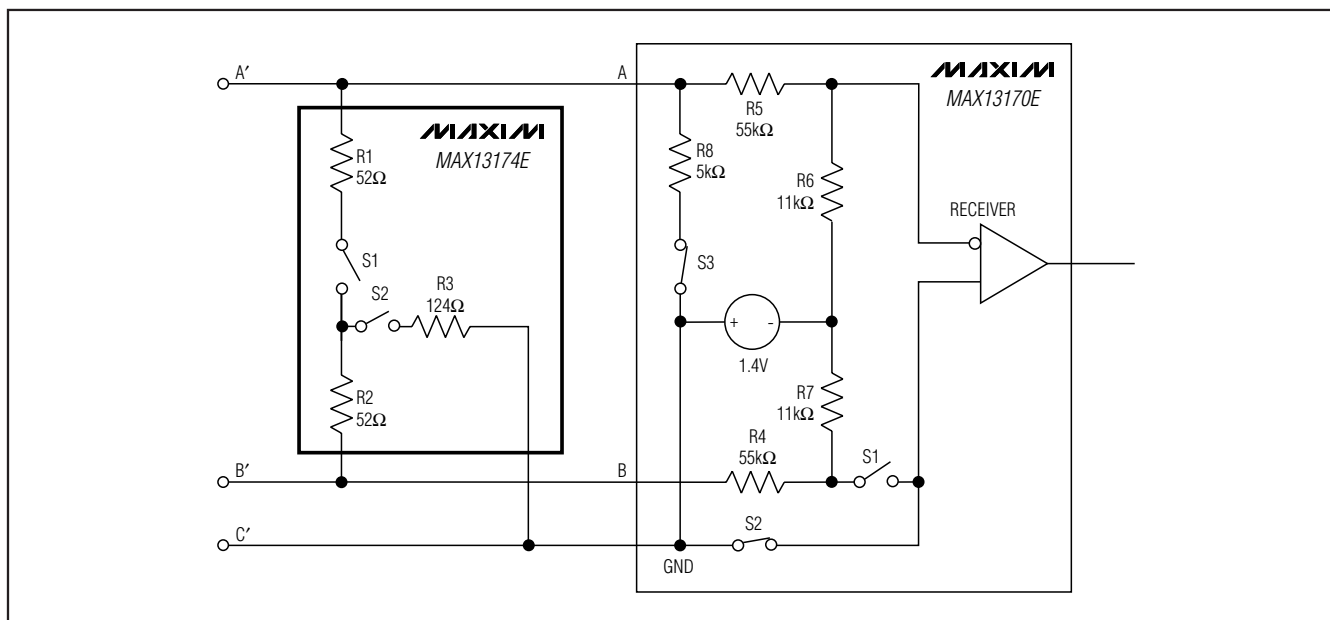

Figure 10. V.28 Termination and Internal Resistance Networks

have extra protection against static electricity. Maxim's engineers have developed state-of-the-art structures to protect these pins against an ESD of $\pm 15\text{kV}$ (Human Body Model) without damage. The ESD structures withstand high ESD in all states: normal operation, shut-down, and powered down. After an ESD event, the MAX13174E keeps working without latchup or damage. ESD protection can be tested in various ways. The *Electrical Characteristics* table shows the limits, and each device is characterized for protection to the following methods:

- Human Body Model
- Contact Method specified in IEC 61000-4-2
- Air Gap Discharge Method specified in IEC 61000-4-2

ESD Test Conditions

ESD performance depends on a variety of conditions. Contact Maxim for a reliability report that documents test setup, test methodology, and test results.

Human Body Model

Figure 12a shows the Human Body Model, and Figure 12b shows the current waveform it generates when discharged into a low impedance. This model consists of a 100pF capacitor charged to the ESD voltage of interest, which is then discharged into the test device through a 1.5k Ω resistor.

IEC 61000-4-2

The IEC 61000-4-2 standard covers ESD testing and the performance of finished equipment. However, it does not specifically refer to integrated circuits. The MAX13174E helps equipment designs to meet IEC 61000-4-2 without the need for additional ESD-protection components.

The major difference between tests done using the Human Body Model and IEC 61000-4-2 is higher peak current in IEC 61000-4-2 because series resistance is lower in the IEC 61000-4-2 model. Figure 12c shows the IEC 61000-4-2 model, and Figure 12d shows the current waveform for the IEC 61000-4-2 ESD Contact Discharge test.

Compliance Testing

A European Standard EN 45001 test report for the MAX13170E, MAX13172E, and MAX13174E chipset will be available from Maxim upon completion of testing. Contact Maxim Quality Assurance for a copy of the report.

+5V Multiprotocol, Pin-Selectable Cable Terminator

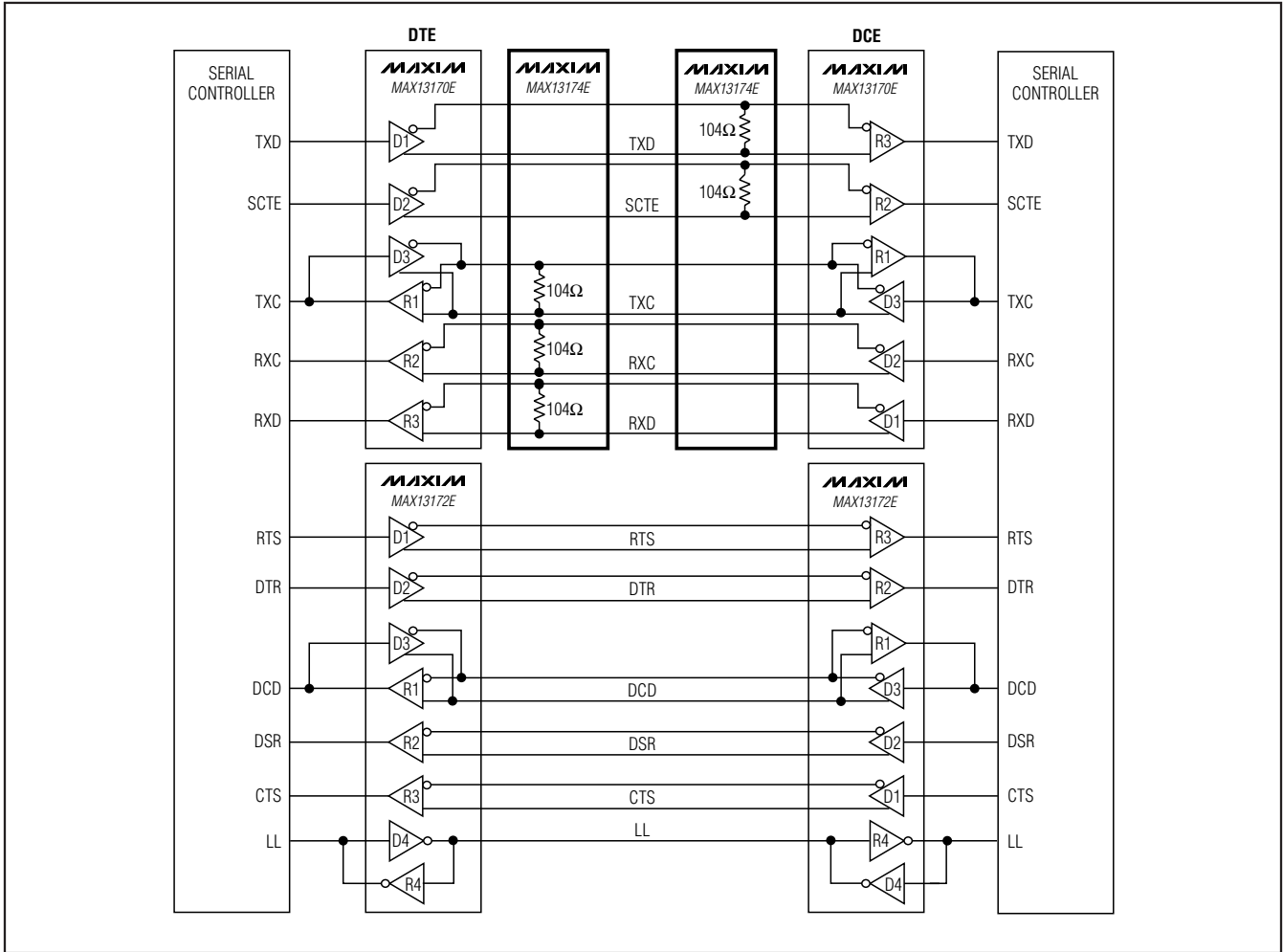

Figure 11. DTE-to-DCE X.21 Interface

+5V Multiprotocol, Pin-Selectable Cable Terminator

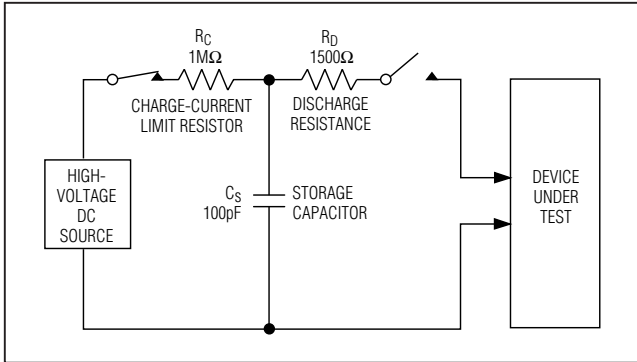

Figure 12a. Human Body ESD Test Model

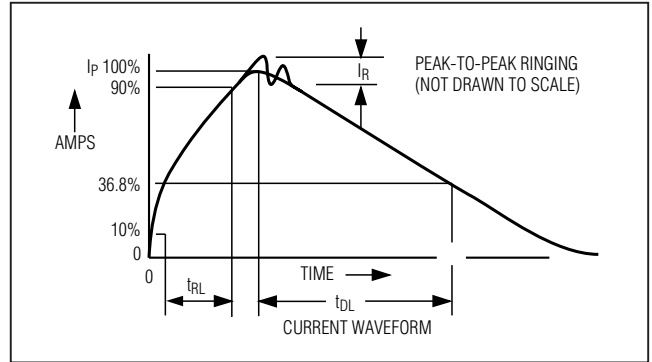

Figure 12b. Human Body Current Waveform

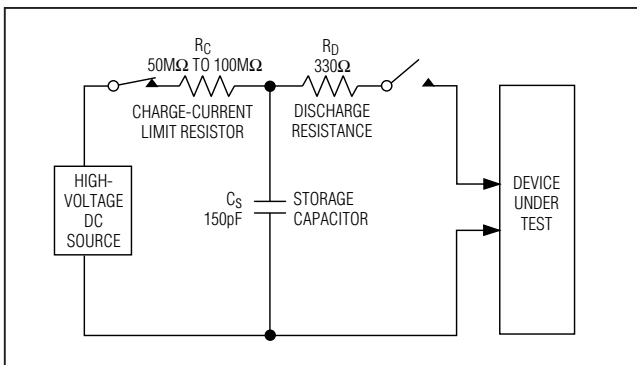

Figure 12c. IEC 61000-4-2 ESD Test Model

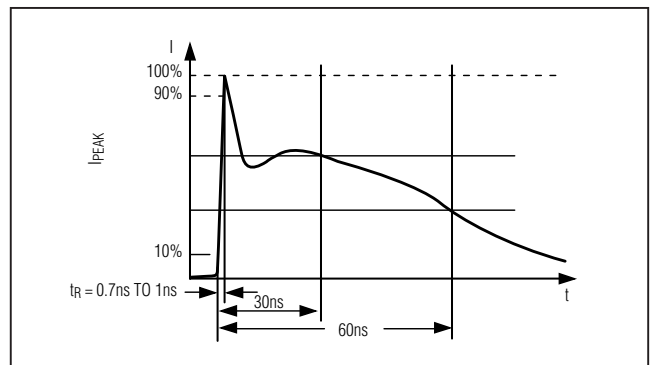
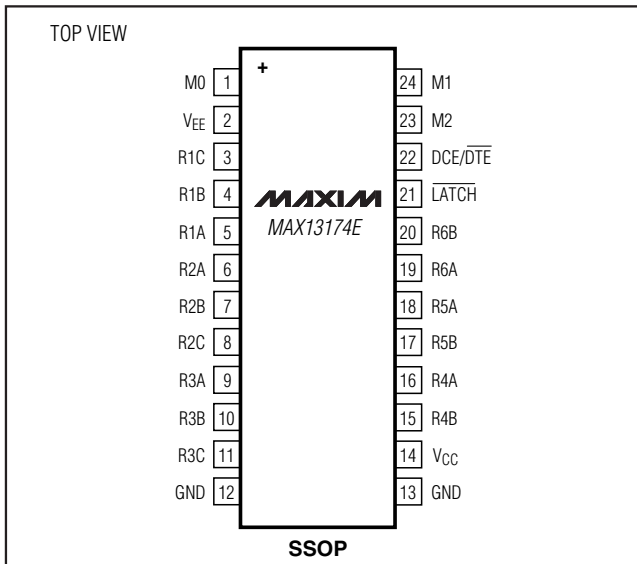

Figure 12d. IEC 61000-4-2 ESD Generator Current Waveform

Pin Configuration



Chip Information

PROCESS: BiCMOS

Package Information

For the latest package outline information and land patterns, go to www.maxim-ic.com/packages.

PACKAGE TYPE	PACKAGE CODE	DOCUMENT NO.
24 SSOP	A24+3	21-0056

Maxim cannot assume responsibility for use of any circuitry other than circuitry entirely embodied in a Maxim product. No circuit patent licenses are implied. Maxim reserves the right to change the circuitry and specifications without notice at any time.

X-ON Electronics

Largest Supplier of Electrical and Electronic Components

Click to view similar products for [Interface - Specialised category](#):

Click to view products by [Maxim manufacturer](#):

Other Similar products are found below :

[CY7C910-51LMB](#) [MEC1632-AUE](#) [RKSAS4](#) [HMC677G32](#) [LPC47N207-JV](#) [FTP-637DSL633R](#) [SM712GX04LF04-BA](#) [MCW1001A-I/SS](#)
[HOA6241-001](#) [SC74HC4066ADTR2G](#) [NCN5120MNTWG](#) [NCN5150DR2G](#) [NCN8025MTTBG](#) [C100N50Z4A](#) [DG407AK/883B](#) [SRT2-ATT01](#) [TDA8035HN/C1/S1J](#) [LTC1694CS5#TRMPBF](#) [DS90UB947TRGCRQ1](#) [SP510ECF-L](#) [NCS2300MUTAG](#) [ADG1404YCPZ-REEL](#)
[HMC677LP5E](#) [HMC677LP5ETR](#) [LTC1756EGN#PBF](#) [LTC1955EUH#PBF](#) [LT3669EUFD-2#PBF](#) [LTC6820HMS#3ZZTRPBF](#)
[MXL1543BCAI](#) [MAX3170CAI+](#) [XL1192D](#) [CP82C59AZ](#) [KTU1109EFAA-TR](#) [CH368L](#) [CH7307C-DEF](#) [LTC1694-1IS5#TRMPBF](#)
[LTC1694CS5#TRPBF](#) [LTC1694IS5#TRM](#) [73S8024RN-20IMF](#) [73S8024RN-IL/F](#) [DS2413P+](#) [DS2413P+T&R](#) [DS28E17Q+](#) [DS8113-RNG+](#)
[MAX13174ECAG+](#) [MAX216CWN+](#) [MAX3172CAI+](#) [AS8222-HSSM](#) [MAX6618AUB+](#) [MAX6817MUT+T](#)