

MAX13442E/MAX13443E/ MAX13444E

±15kV ESD-Protected, ±80V Fault-Protected, Fail-Safe RS-485/J1708 Transceivers

General Description

The MAX13442E/MAX13444E are fault-protected RS-485 and J1708 transceivers that feature ±80V protection from signal faults on communication bus lines. The MAX13442E/MAX13444E feature a reduced slew-rate driver that minimizes EMI and reflections, allowing error-free transmission up to 250kbps. The MAX13443E driver can transmit up to 10Mbps. The high-speed MAX13443E RS-485 transceiver features ±60V protection from signal faults on communication bus lines. These transceivers feature foldback current limit. Each device contains one differential line driver with three-state output and one differential line receiver with three-state input. The 1/4-unit-load receiver input impedance allows up to 128 transceivers on a single bus. The devices operate from a 5V supply. True fail-safe inputs guarantee a logic-high receiver output when the receiver inputs are open, shorted, or connected to an idle data line.

Hot-swap circuitry eliminates false transitions on the data bus during circuit initialization or connection to a live backplane. Short-circuit current-limiting and thermal-shutdown circuitry protect the driver against excessive power dissipation, and on-chip ±15kV ESD protection eliminates costly external protection devices.

The MAX13442E/MAX13443E/MAX13444E are available in an 8-pin SO package and are specified over the automotive temperature range.

Features

- ±15kV ESD Protection
- ±80V Fault Protection (±60V MAX13443E)
- Guaranteed 10Mbps Data Rate (MAX13443E)
- Hot-Swappable for Telecom Applications
- True Fail-Safe Receiver Inputs
- Enhanced Slew-Rate-Limiting Facilitates Error-Free Data Transmission (MAX13442E/MAX13444E)
- Allow Up to 128 Transceivers on the Bus
- -7V to +12V Common-Mode Input Range
- ±6mA FoldBack Current Limit
- Industry-Standard Pinout

Applications

- RS-422/RS-485 Communications
- Truck and Trailer Applications
- Industrial Networks
- Telecommunications Systems
- Automotive Applications
- HVAC Controls

Ordering Information

PART	TEMP RANGE	PIN-PACKAGE
MAX13442EASA+	-40°C to +125°C	8 SO
MAX13443EASA+	-40°C to +125°C	8 SO
MAX13444EASA/V+T	-40°C to +125°C	8 SO

+Denotes lead (Pb)-free/RoHS-compliant package.

/V denotes an automotive qualified part.

T = Tape and reel.

Selector Guide

PART	TYPE	DATA RATE (Mbps)	FAULT PROTECTION (V)	LOW-POWER SHUTDOWN	RECEIVER/DRIVER ENABLE	TRANSCIEVERS ON BUS	HOT SWAP
MAX13442E	RS-485	0.25	±80	Yes	Yes	128	Yes
MAX13443E	RS-485	10	±60	Yes	Yes	128	Yes
MAX13444E	J1708	0.25	±80	Yes	Yes	128	Yes (only RE)

Pin Configurations and Typical Operating Circuits

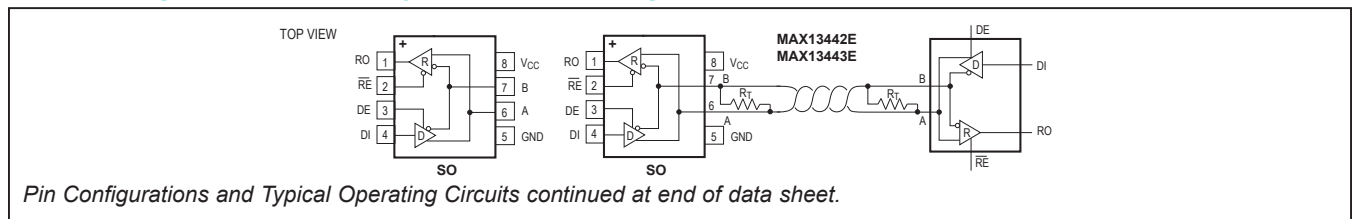

MAX13442E/MAX13443E/
MAX13444E

±15kV ESD-Protected, ±80V Fault-Protected,
Fail-Safe RS-485/J1708 Transceivers

Absolute Maximum Ratings

(Voltages referenced to GND.)

V_{CC}.....+7V
 RE, DE, DE, DI, TXD-0.3V to (V_{CC} + 0.3V)
 A, B (Note 1) (MAX13442E/MAX13444E).....±80V
 A, B (Note 1) (MAX13443E).....±60V
 RO-0.3V to (V_{CC} + 0.3V)
 Short-Circuit Duration (RO, A, B).....Continuous

Continuous Power Dissipation (T_A = +70°C)
 SO (derate 7.6mW/°C above +70°C).....606mW
 Operating Temperature Range.....-40°C to +125°C
 Storage Temperature Range.....-65°C to +150°C
 Junction Temperature.....+150°C
 Lead Temperature (soldering, 10s).....+300°C
 Soldering Temperature (reflow).....+260°C

Note 1: During normal operation, a termination resistor must be connected between A and B in order to guarantee overvoltage protection up to the absolute maximum rating of this device. When not in operation, these devices can withstand fault voltages up to the maximum rating without a termination resistor and will not be damaged.

Stresses beyond those listed under "Absolute Maximum Ratings" may cause permanent damage to the device. These are stress ratings only, and functional operation of the device at these or any other conditions beyond those indicated in the operational sections of the specifications is not implied. Exposure to absolute maximum rating conditions for extended periods may affect device reliability.

Package Thermal Characteristics (Note 2)

SO

Junction-to-Ambient Thermal Resistance (θ_{JA})132°C/W Junction-to-Case Thermal Resistance (θ_{JC}).....38°C/W

Note 1: Package thermal resistances were obtained using the method described in JEDEC specification JESD51-7, using a four-layer board. For detailed information on package thermal considerations, refer to www.maximintegrated.com/thermal-tutorial.

DC Electrical Characteristics

(V_{CC} = +4.75V to +5.25V, T_A = T_{MIN} to T_{MAX}, unless otherwise noted. Typical values are at V_{CC} = +5V and T_A = +25°C.)

PARAMETER	SYMBOL	CONDITIONS	MIN	TYP	MAX	UNITS
DRIVER						
Differential Driver Output	V _{OD}	Figure 1, R _L = 100Ω	2		V _{CC}	V
		Figure 1, R _L = 54Ω	1.5		V _{CC}	
Change in Magnitude of Differential Output Voltage	ΔV _{OD}	Figure 1, R _L = 100Ω or 54Ω (Note 3)			0.2	V
Driver Common-Mode Output Voltage	V _{OC}	Figure 1, R _L = 100Ω or 54Ω		V _{CC} /2	3	V
Change in Magnitude of Common-Mode Voltage	DV _{OC}	Figure 1, R _L = 100Ω or 54Ω (Note 3) (MAX13442E/MAX13443E)			0.2	V
DRIVER LOGIC						
Driver-Input High Voltage	V _{DIH}		2			V
Driver-Input Low Voltage	V _{DIL}				0.8	V
Driver-Input Current	I _{DIN}				±2	μA
Driver Short-Circuit Output Current (Note 4)	I _{OSD}	0V ≤ V _{OUT} ≤ +12V			+350	mA
		-7V ≤ V _{OUT} ≤ V _{CC}	-350			
Driver Short-Circuit Foldback Output Current	I _{OSDF}	(V _{CC} - 1V) ≤ V _{OUT} ≤ +12V (Note 4)	+25			mA
		-7V ≤ V _{OUT} ≤ +1V (Note 4)			-25	
Driver-Limit Short-Circuit Foldback Output Current	I _{OSDL}	V _{OUT} ≥ +20V, R _L = 100Ω	+6			mA
		V _{OUT} ≤ -15V, R _L = 100Ω			-6	

MAX13442E/MAX13443E/
MAX13444E

±15kV ESD-Protected, ±80V Fault-Protected,
Fail-Safe RS-485/J1708 Transceivers

DC Electrical Characteristics (continued)

(V_{CC} = +4.75V to +5.25V, T_A = T_{MIN} to T_{MAX}, unless otherwise noted. Typical values are at V_{CC} = +5V and T_A = +25°C.)

PARAMETER	SYMBOL	CONDITIONS	MIN	TYP	MAX	UNITS
RECEIVER						
Input Current	I _{A,B}	A, B receive mode	V _{CC} = GND, V _{A, B} = 12V		250	μA
			V _{A, B} = -7V		-150	
			V _{A, B} = ±80V		±6	mA
Receiver-Differential Threshold Voltage	V _{TH}	-7V ≤ V _{CM} ≤ +12V	-200		-50	mV
Receiver-Input Hysteresis	ΔV _{TH}			25		mV
RECEIVER LOGIC						
Output-High Voltage	V _{OH}	Figure 2, I _{OH} = -1.6mA	V _{CC} - 0.6			V
Output-Low Voltage	V _{OL}	Figure 2, I _{OL} = 1mA			0.4	V
Three-State Output Current at Receiver	I _{OZR}	0V ≤ V _{A, B} ≤ V _{CC}			±1	μA
Receiver Input Resistance	R _{IN}	-7V ≤ V _{CM} ≤ +12V	48			kΩ
Receiver Output Short-Circuit Current	I _{OSR}	0V ≤ V _{RO} ≤ V _{CC}			±95	mA
CONTROL						
Control-Input High Voltage	V _{CIH}	DE, \overline{DE} , \overline{RE}	2			V
Input-Current Latch During First Rising Edge	I _{IN}	DE, \overline{RE}		90		μA
SUPPLY CURRENT						
Normal Operation	I _{CC}	No load, DI = V _{CC} or GND	DE = V _{CC} , \overline{RE} = GND (MAX13442E) (\overline{DE} = \overline{RE} = GND) (MAX13444E)		30	mA
			(DE = V _{CC} , \overline{RE} = GND) (MAX13443E)		10	
Supply Current in Shutdown Mode	I _{SHDN}		DE = GND, \overline{RE} = V _{CC} (MAX13442E/MAX13443E)		20	μA
			DE = GND, \overline{RE} = V _{CC} , T _A = +25°C (MAX13442E/MAX13443E)		10	
			\overline{DE} = \overline{RE} = V _{CC} (MAX13444E)		100	
			\overline{DE} = \overline{RE} = V _{CC} , T _A = +25°C (MAX13444E)		10	
Supply Current with Output Shorted to ±60V	I _{SHRT}	DE = GND, \overline{RE} = GND, no load output in three-state (MAX13443E)			±15	mA

MAX13442E/MAX13443E/
MAX13444E

±15kV ESD-Protected, ±80V Fault-Protected,
Fail-Safe RS-485/J1708 Transceivers

Protection Specifications

(V_{CC} = +4.75V to +5.25V, T_A = T_{MIN} to T_{MAX}, unless otherwise noted. Typical values are at V_{CC} = +5V and T_A = +25°C.)

PARAMETER	SYMBOL	CONDITIONS	MIN	TYP	MAX	UNITS
Overvoltage Protection		A, B; R _{SOURCE} = 0Ω, R _L = 54Ω	MAX13442E/ MAX13444E		±80	V
			MAX13443E		±60	
ESD Protection		A, B	Human Body Model		±15	kV

Switching Characteristics (MAX13442E/MAX13444E)

(V_{CC} = +4.75V to +5.25V, T_A = T_{MIN} to T_{MAX}, unless otherwise noted. Typical values are at V_{CC} = +5V and T_A = +25°C.)

PARAMETER	SYMBOL	CONDITIONS	MIN	TYP	MAX	UNITS
Driver Propagation Delay	t _{PLHA} , t _{PLHB}	Figure 3, R _L = 54Ω, C _L = 50pF (MAX13442E)			2000	ns
		R _{DIFF} = 60Ω, C _{DIFF} = 100pF (MAX13444E)				
Driver Differential Propagation Delay	t _{DPLH} , t _{DPHL}	R _L = 54Ω, C _L = 50pF, Figure 4			2000	ns
Driver Differential Output Transition Time	t _{LH} , t _{HL}	R _L = 54Ω, C _L = 50pF, Figure 4	200		2000	ns
Driver Output Skew	t _{SKEWAB} , t _{SKEWBA}	R _L = 54Ω, C _L = 50pF, t _{SKEWAB} = t _{PLHA} - t _{PHLB} , t _{SKEWBA} = t _{PLHB} - t _{PHLA}			350	ns
Differential Driver Output Skew	t _{DSKEW}	R _L = 54Ω, C _L = 50pF, t _{DSKEW} = t _{DPLH} - t _{DPHL}			200	ns
Maximum Data Rate	f _{MAX}		250			kbps
Driver Enable Time to Output High	t _{PDZH}	R _L = 500Ω, C _L = 50pF, Figure 5			2000	ns
Driver Disable Time from Output High	t _{PDHZ}	R _L = 500Ω, C _L = 50pF, Figure 5			2000	ns
Driver Enable Time from Shutdown to Output High	t _{PDHS}	R _L = 500Ω, C _L = 50pF, Figure 5			4.2	μs
Driver Enable Time to Output Low	t _{PDZL}	R _L = 500Ω, C _L = 50pF, Figure 6			2000	ns
Driver Disable Time from Output Low	t _{PD LZ}	R _L = 500Ω, C _L = 50pF, Figure 6			2000	ns
Driver Enable Time from Shutdown to Output Low	t _{PDLS}	R _L = 500Ω, C _L = 50pF, Figure 6			4.2	μs
Driver Time to Shutdown	t _{SHDN}	R _L = 500Ω, C _L = 50pF			800	ns
Receiver Propagation Delay	t _{RPLH} , t _{RPHL}	C _L = 20pF, V _{ID} = 2V, V _{CM} = 0V, Figure 7			2000	ns
Receiver Output Skew	t _{RSKEW}	C _L = 20pF, t _{RSKEW} = t _{RPLH} - t _{RPHL}			200	ns
Receiver Enable Time to Output High	t _{RPZH}	R _L = 1kΩ, C _L = 20pF, Figure 8			2000	ns
Receiver Disable Time from Output High	t _{RPHZ}	R _L = 1kΩ, C _L = 20pF, Figure 8			2000	ns
Receiver Wake Time from Shutdown	t _{RPWAKE}	R _L = 1kΩ, C _L = 20pF, Figure 8			4.2	μs
Receiver Enable Time to Output Low	t _{RPZL}	R _L = 1kΩ, C _L = 20pF, Figure 8			2000	ns
Receiver Disable Time from Output Low	t _{RPLZ}	R _L = 1kΩ, C _L = 20pF, Figure 8			2000	ns
Receiver Time to Shutdown	t _{SHDN}	R _L = 500Ω, C _L = 50pF			800	ns

Switching Characteristics (MAX13443E)

($V_{CC} = +4.75V$ to $+5.25V$, $T_A = T_{MIN}$ to T_{MAX} , unless otherwise noted. Typical values are at $V_{CC} = +5V$ and $T_A = +25^\circ C$.)

PARAMETER	SYMBOL	CONDITIONS	MIN	TYP	MAX	UNITS
Driver Propagation Delay	t_{PLHA} , t_{PLHB}	$R_L = 27\Omega$, $C_L = 50pF$, Figure 3			60	ns
Driver Differential Propagation Delay	t_{DPLH} , t_{DPHL}	$R_L = 54\Omega$, $C_L = 50pF$, Figure 4			60	ns
Driver Differential Output Transition Time	t_{LH} , t_{HL}	$R_L = 54\Omega$, $C_L = 50pF$, Figure 4			25	ns
Driver Output Skew	t_{SKEWAB} , t_{SKEWBA}	$R_L = 54\Omega$, $C_L = 50pF$, $t_{SKEWAB} = t_{PLHA} - t_{PHLB} $, $t_{SKEWBA} = t_{PLHB} - t_{PHLA} $			10	ns
Differential Driver Output Skew	t_{DSKEW}	$R_L = 54\Omega$, $C_L = 50pF$, $t_{DSKEW} = t_{DPLH} - t_{DPHL} $			10	ns
Maximum Data Rate	f_{MAX}		10			Mbps
Driver Enable Time to Output High	t_{PDZH}	$R_L = 500\Omega$, $C_L = 50pF$, Figure 5			1200	ns
Driver Disable Time from Output High	t_{PDHZ}	$R_L = 500\Omega$, $C_L = 50pF$, Figure 5			1200	ns
Driver Enable Time from Shutdown to Output High	t_{PDHS}	$R_L = 500\Omega$, $C_L = 50pF$, Figure 5			4.2	μs
Driver Enable Time to Output Low	t_{PDZL}	$R_L = 500\Omega$, $C_L = 50pF$, Figure 6			1200	ns
Driver Disable Time from Output Low	t_{PDLZ}	$R_L = 500\Omega$, $C_L = 50pF$, Figure 6			1200	ns
Driver Enable Time from Shutdown to Output Low	t_{PDLS}	$R_L = 500\Omega$, $C_L = 50pF$, Figure 6			4.2	Fs
Driver Time to Shutdown	t_{SHDN}	$R_L = 500\Omega$, $C_L = 50pF$, Figure 6			800	ns
Receiver Propagation Delay	t_{RPLH} , t_{RPHL}	$C_L = 20pF$, $V_{ID} = 2V$, $V_{CM} = 0V$, Figure 7			85	ns
Receiver Output Skew	t_{RSKEW}	$C_L = 20pF$, $t_{RSKEW} = t_{RPLH} - t_{RPHL} $			15	ns
Receiver Enable Time to Output High	t_{RPZH}	$R_L = 1k\Omega$, $C_L = 20pF$, Figure 8			400	ns
Receiver Disable Time from Output High	t_{RPHZ}	$R_L = 1k\Omega$, $C_L = 20pF$, Figure 8			400	ns
Receiver Wake Time from Shutdown	t_{RPWAKE}	$R_L = 1k\Omega$, $C_L = 20pF$, Figure 8			4.2	μs
Receiver Enable Wake Time from Shutdown	t_{RPSH}	$R_L = 1k\Omega$, $C_L = 20pF$, Figure 8			400	ns
Receiver Disable Time from Output Low	t_{RPLZ}	$R_L = 1k\Omega$, $C_L = 20pF$, Figure 8			400	ns
Receiver Time to Shutdown	t_{SHDN}	$R_L = 500\Omega$, $C_L = 50pF$			800	ns

Note 3: ΔV_{OD} and ΔV_{OC} are the changes in V_{OD} and V_{OC} , respectively, when the DI input changes state.

Note 4: The short-circuit output current applies to peak current just before foldback current limiting. The short-circuit foldback output current applies during current limiting to allow a recovery from bus contention.

Typical Operating Characteristics

($V_{CC} = +5V$, $T_A = +25^\circ C$, unless otherwise noted.)

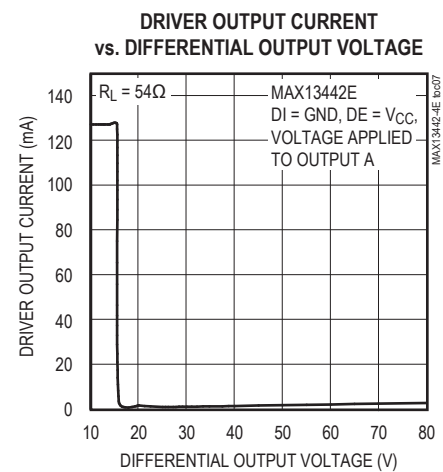
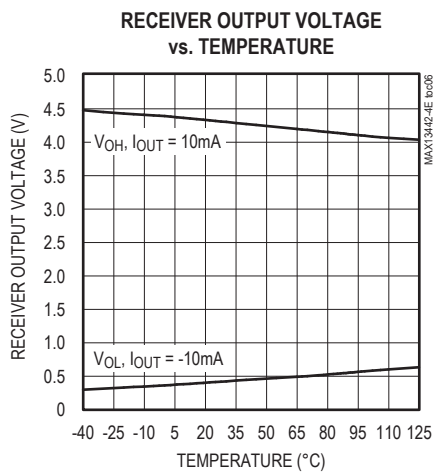
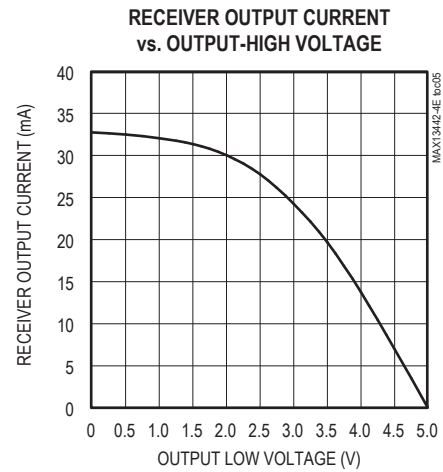
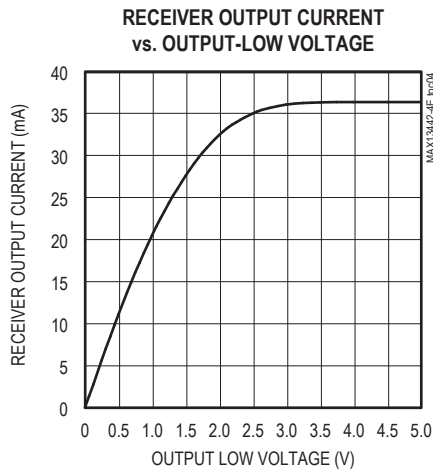
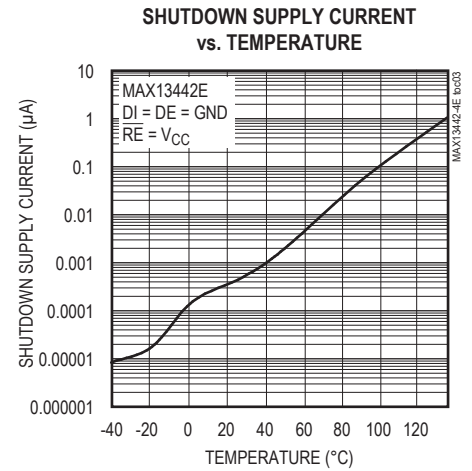
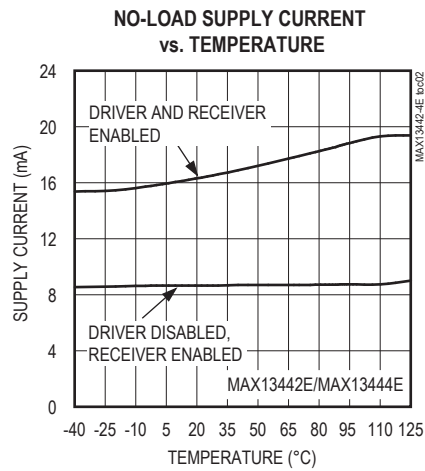
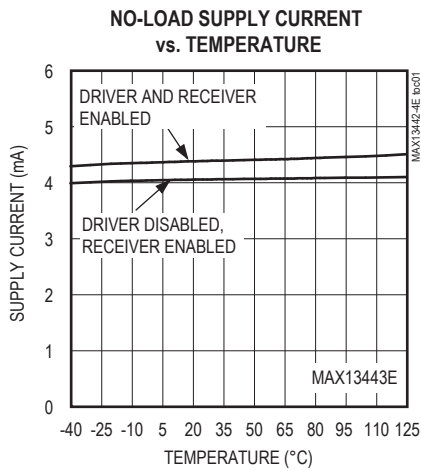

Typical Operating Characteristics (continued)

(V_{CC} = +5V, T_A = +25°C, unless otherwise noted.)

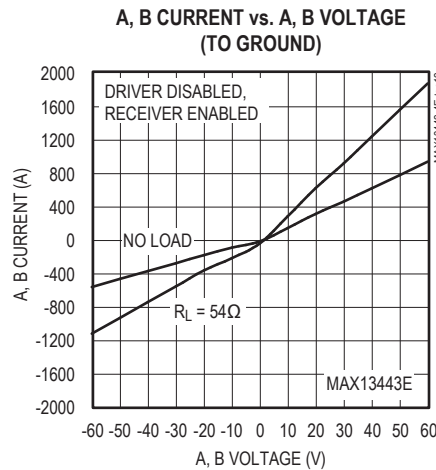
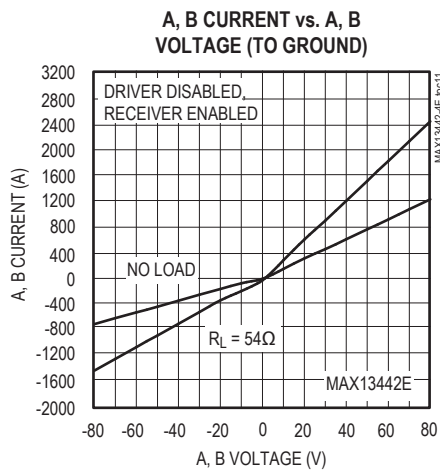
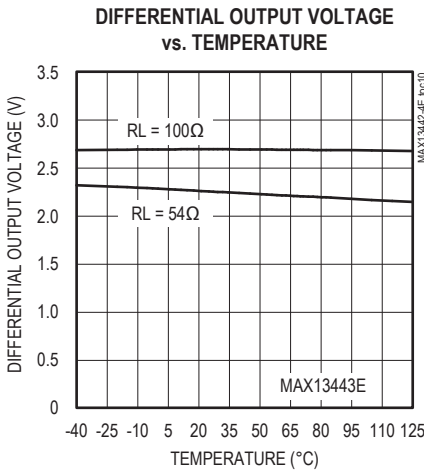
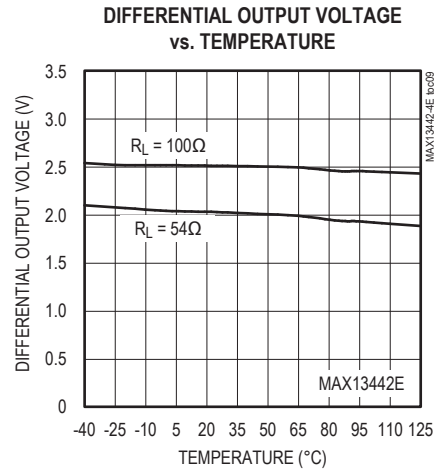
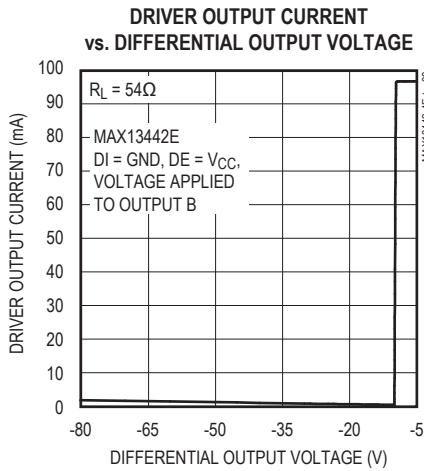

Test Circuits and Waveforms

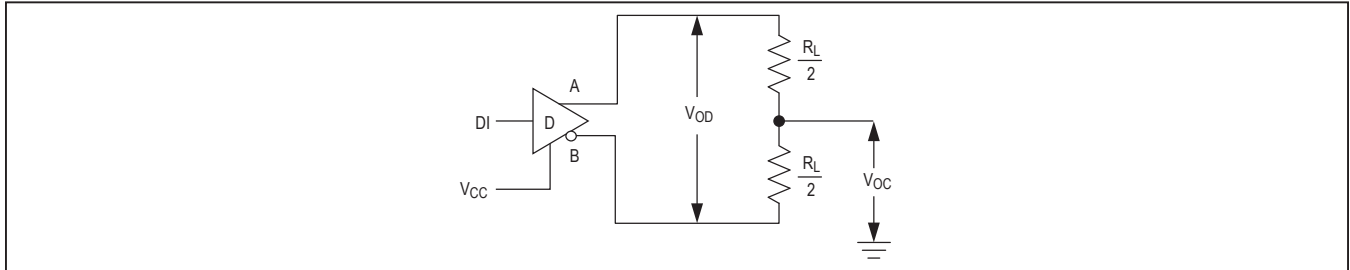

Figure 1. Driver V_{OD} and V_{OC}

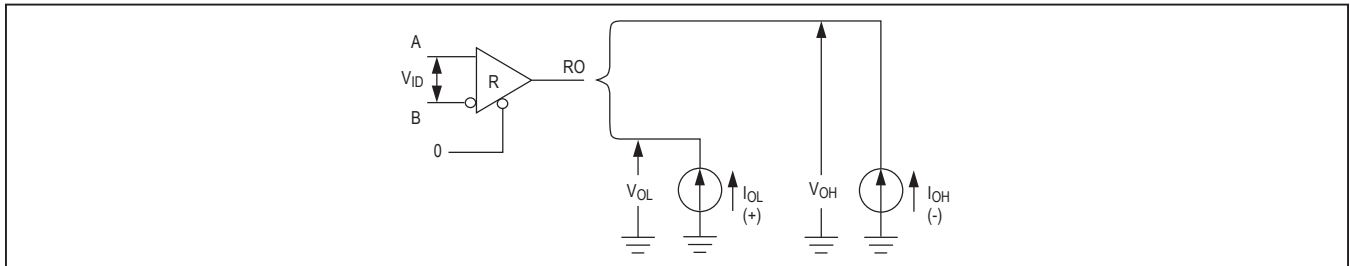

Figure 2. Receiver V_{OH} and V_{OL}

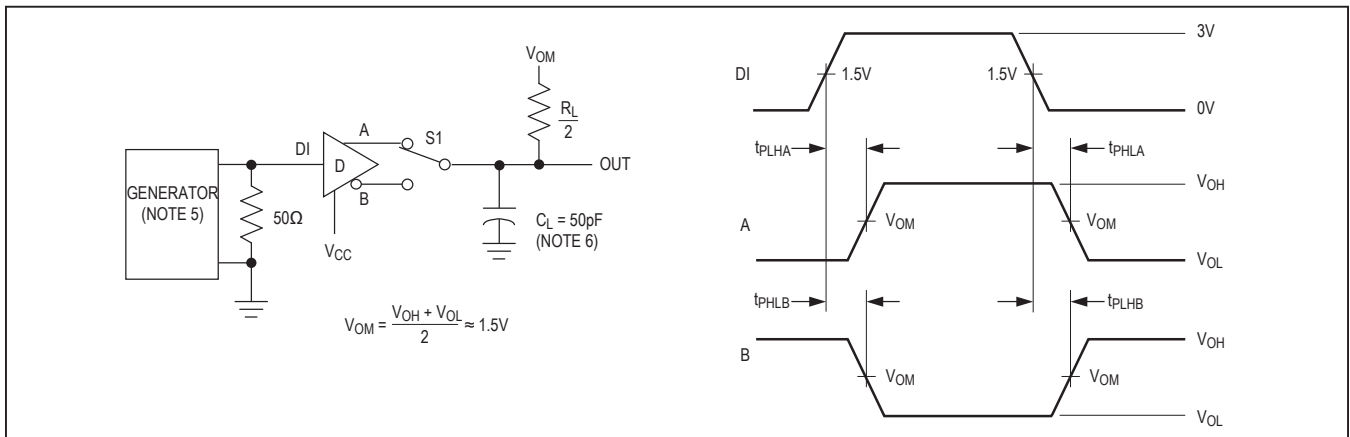

Figure 3. Driver Propagation Times

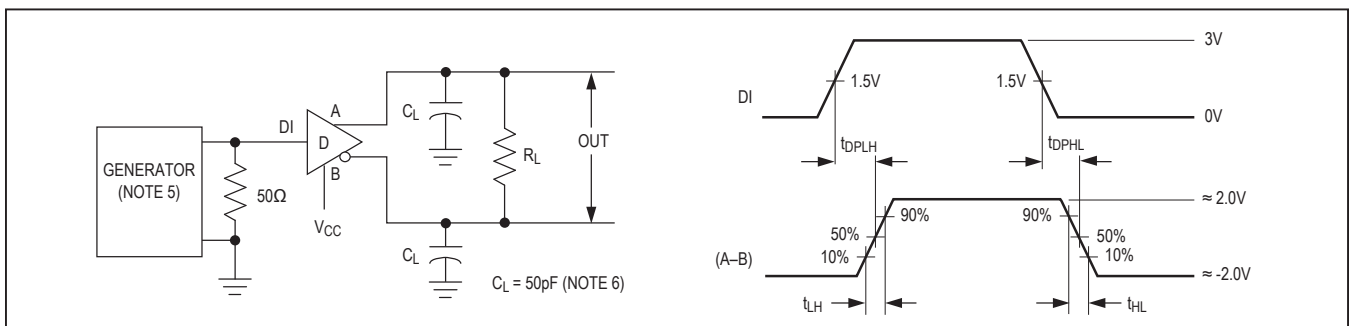

Figure 4. Driver Differential Output Delay and Transition Times

Test Circuits and Waveforms (continued)

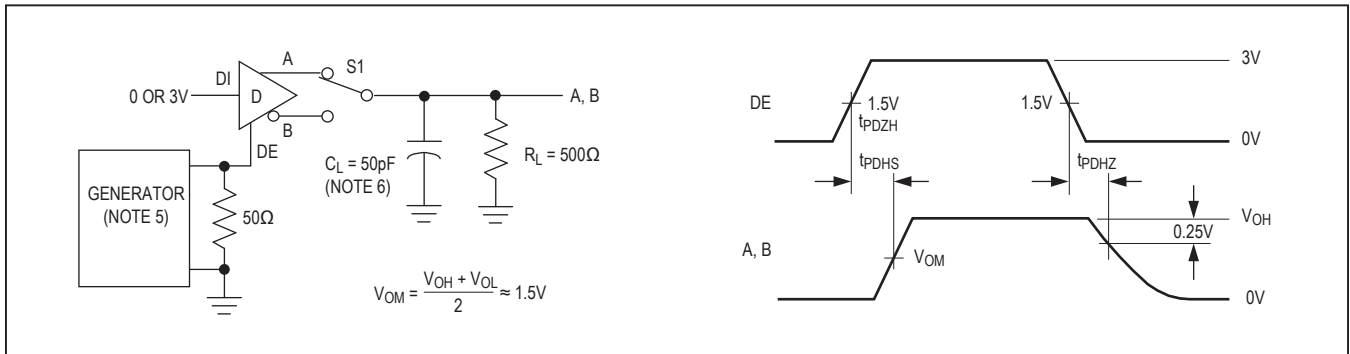

Figure 5. Driver Enable and Disable Times

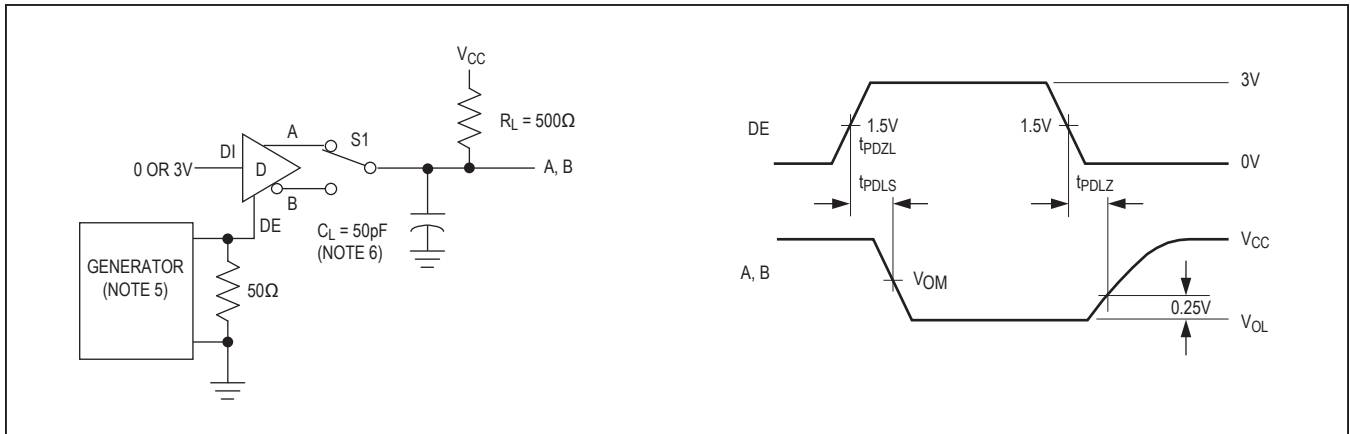

Figure 6. Driver Enable and Disable Times

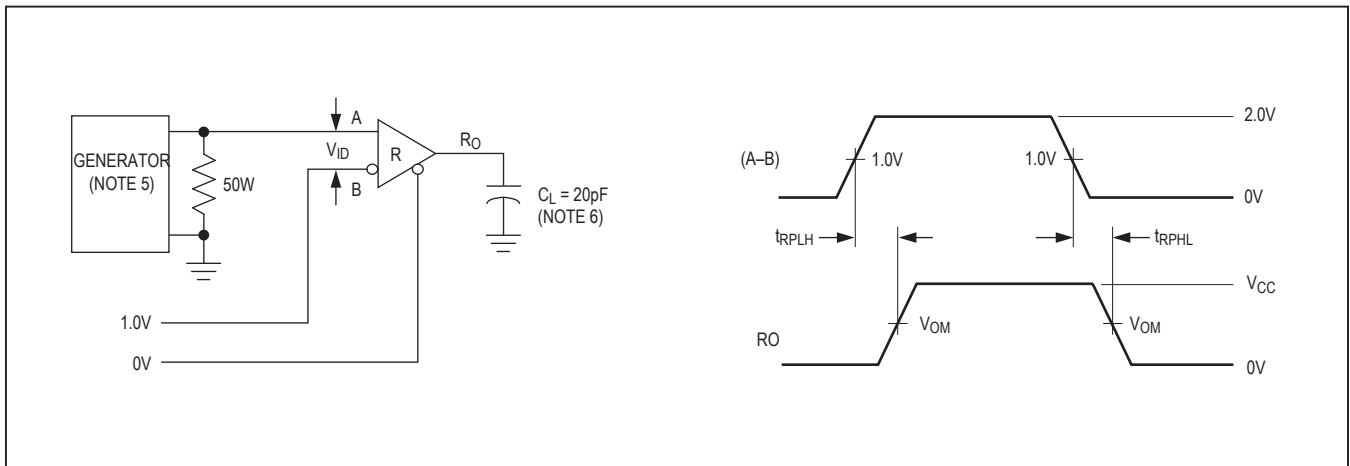

Figure 7. Receiver Propagation Delay

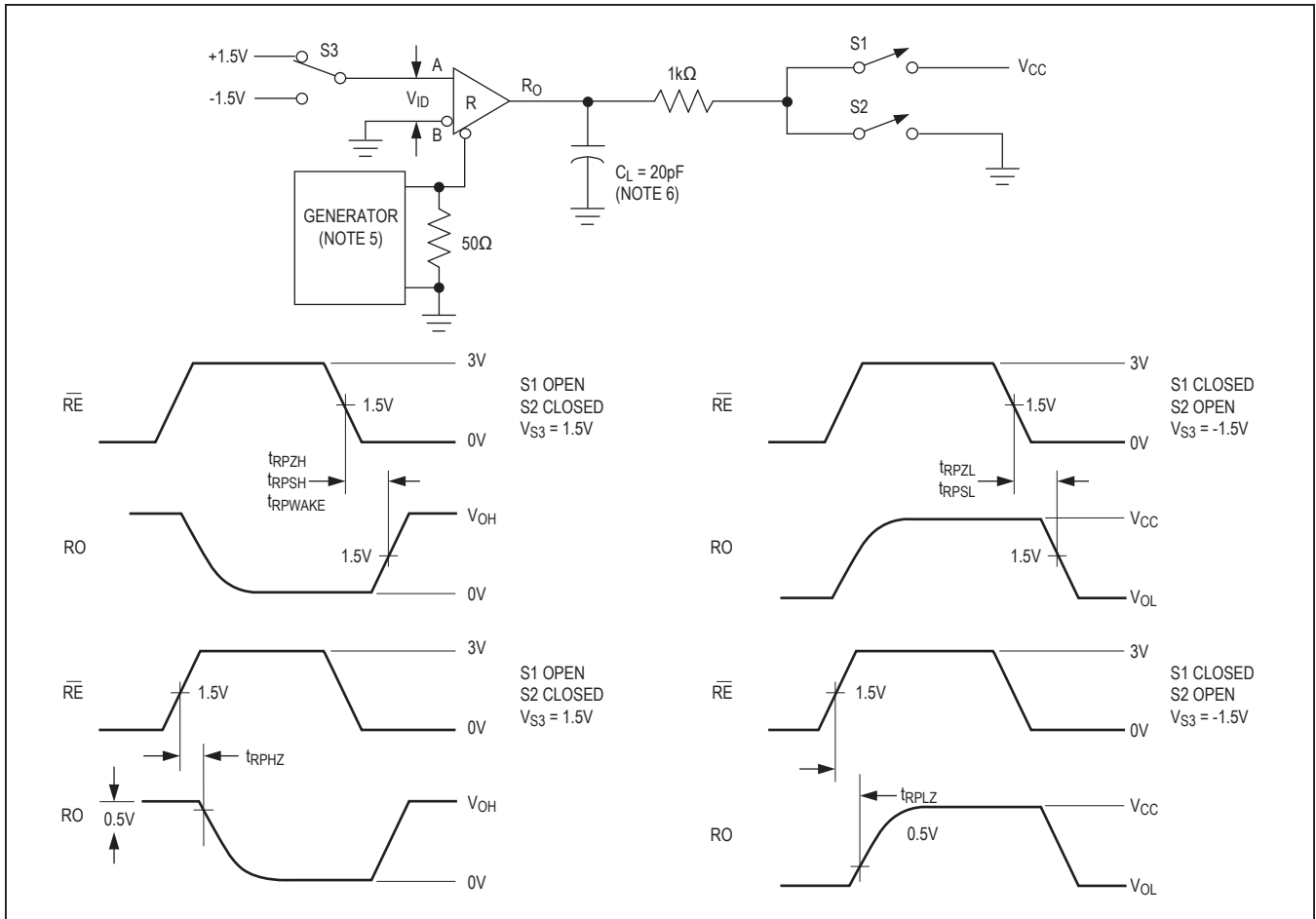

Figure 8. Receiver Enable and Disable Times

Note 5: The input pulse is supplied by a generator with the following characteristics: $f = 5\text{MHz}$, 50% duty cycle; $t_r \leq 6\text{ns}$; $Z_0 = 50\Omega$.

Note 6: C_L includes probe and stray capacitance.

Pin Description

PIN		NAME	FUNCTION
MAX13442E MAX13443E	MAX13444E		
1	1	RO	Receiver Output. If the receiver is enabled and $(V_A - V_B) \geq -50\text{mV}$, RO = high; if $(V_A - V_B) \leq -200\text{mV}$, RO = low.
2	2	$\overline{\text{RE}}$	Receiver Output Enable. Pull $\overline{\text{RE}}$ low to enable RO.
3	—	DE	Driver Output Enable. Force DE high to enable driver. Pull DE low to three-state the driver output. Drive $\overline{\text{RE}}$ high and pull DE low to enter low-power shutdown mode.
4	—	DI	Driver Input. A logic-low on DI forces the noninverting output low and the inverting output high. A logic-high on DI forces the noninverting output high and the inverting output low.
5	5	GND	Ground
6	6	A	Noninverting Receiver Input/Driver Output
7	7	B	Inverting Receiver Input/Driver Output
8	8	V_{CC}	Positive Supply, $V_{\text{CC}} = +4.75\text{V}$ to $+5.25\text{V}$. For normal operation, bypass V_{CC} to GND with a $0.1\mu\text{F}$ ceramic capacitor. For full ESD protection, bypass V_{CC} to GND with $1\mu\text{F}$ ceramic capacitor.
—	3	$\overline{\text{DE}}$	Driver Output Enable. Pull $\overline{\text{DE}}$ low to enable the outputs. Force $\overline{\text{DE}}$ high to three-state the outputs. Drive $\overline{\text{RE}}$ and $\overline{\text{DE}}$ high to enter low-power shutdown mode.
—	4	TXD	J1708 Input. A logic-low on TXD forces outputs A and B to the dominant state. A logic-high on TXD forces outputs A and B to the recessive state.

Function Tables

Table 1. MAX13442E/MAX13443E
(RS-485/RS-422)

TRANSMITTING				
INPUTS			OUTPUTS	
\overline{RE}	DE	DI	A	B
0	0	X	High-Z	High-Z
0	1	0	0	1
0	1	1	1	0
1	0	X	Shutdown	Shutdown
1	1	0	0	1
1	1	1	1	0

X = Don't care.

Table 3. MAX13442E/MAX13443E
(RS-485/RS-422)

RECEIVING			
INPUTS			OUTPUTS
\overline{RE}	DE	($V_A - V_B$)	RO
0	X	$\geq -0.05V$	1
0	X	$\leq -0.2V$	0
0	X	Open/shorted	1
1	1	X	High-Z
1	0	X	Shutdown

X = Don't care.

Table 2. MAX13444E (J1708) Application

TRANSMITTING				
INPUTS		OUTPUTS		CONDITIONS
TXD	\overline{DE}	A	B	—
0	1	High-Z	High-Z	—
1	1	High-Z	High-Z	—
0	0	0	1	Dominant state
1	0	High-Z	High-Z	Recessive state

Table 4. MAX13444E (RS-485/RS-422)

RECEIVING			
INPUTS			OUTPUTS
\overline{RE}	\overline{DE}	($V_A - V_B$)	RO
0	X	$\geq -0.05V$	1
0	X	$\leq -0.2V$	0
0	X	Open/shorted	1
1	0	X	High-Z
1	1	X	Shutdown

X = Don't care.

Detailed Description

The MAX13442E/MAX13443E/MAX13444E fault-protected transceivers for RS-485/RS-422 and J1708 communication contain one driver and one receiver. These devices feature fail-safe circuitry, which guarantees a logic-high receiver output when the receiver inputs are open or shorted, or when they are connected to a terminated transmission line with all drivers disabled (see the *True Fail-Safe* section). All devices have a hot-swap input structure that prevents disturbances on the differential signal lines when a circuit board is plugged into a hot backplane (see the *Hot-Swap Capability* section). The MAX13442E/MAX13444E feature a reduced slew-rate driver that minimizes EMI and reduces reflections caused by improperly terminated cables, allowing error-free data transmission up to 250kbps (see the *Reduced EMI and Reflections* section). The MAX13443E driver is not slew-rate limited, allowing transmit speeds up to 10Mbps.

Driver

The driver accepts a single-ended, logic-level input (DI) and transfers it to a differential, RS-485/RS-422 level output (A and B). Deasserting the driver enable places the driver outputs (A and B) into a high-impedance state.

Receiver

The receiver accepts a differential, RS-485/RS-422 level input (A and B), and transfers it to a single-ended logic-level output (RO). Deasserting the receiver enable places the receiver inputs (A and B) into a high-impedance state (see [Table 1–Table 4](#)).

Low-Power Shutdown

The MAX13442E/MAX13443E/MAX13444E offer a low-power shutdown mode. Force \overline{DE} low and \overline{RE} high to shut down the MAX13442E/MAX13443E. Force \overline{DE} and \overline{RE} high to shut down the MAX13444E. A time delay of 50ns prevents the device from accidentally entering shutdown due to logic skews when switching between transmit and receive modes. Holding \overline{DE} low and \overline{RE} high for at least 800ns guarantees that the MAX13442E/MAX13443E enter shutdown. In shutdown, the devices consume a maximum 20 μ A supply current.

±80V Fault Protection

The driver outputs/receiver inputs of RS-485 devices in industrial network applications often experience voltage faults resulting from shorts to the power grid that exceed the -7V to +12V range specified in the EIA/TIA-485 standard. In these applications, ordinary RS-485 devices (typical absolute maximum -8V to +12.5V) require costly external protection devices. To reduce system complexity and eliminate this need for external protection, the driver

outputs/receiver inputs of the MAX13442E/MAX13444E withstand voltage faults up to ±80V (±60V for the MAX13443E) with respect to ground without damage. Protection is guaranteed regardless whether the device is active, shut down, or without power.

True Fail-Safe

The MAX13442E/MAX13443E/MAX13444E use a -50mV to -200mV differential input threshold to ensure true fail-safe receiver inputs. This threshold guarantees the receiver outputs a logic-high for shorted, open, or idle data lines. The -50mV to -200mV threshold complies with the ±200mV threshold EIA/TIA-485 standard.

±15kV ESD Protection

As with all Maxim devices, ESD-protection structures are incorporated on all pins to protect against ESD encountered during handling and assembly. The MAX13442E/MAX13443E/MAX13444E receiver inputs/driver outputs (A, B) have extra protection against static electricity found in normal operation. Maxim's engineers have developed state-of-the-art structures to protect these pins against ±15kV ESD without damage. After an ESD event, the MAX13442E/MAX13443E/MAX13444E continue working without latchup.

ESD protection can be tested in several ways. The receiver inputs are characterized for protection to ±15kV using the Human Body Model.

ESD Test Conditions

ESD performance depends on a number of conditions. Contact Maxim for a reliability report that documents test setup, methodology, and results.

Human Body Model

[Figure 9a](#) shows the Human Body Model, and [Figure 9b](#) shows the current waveform it generates when discharged into a low impedance. This model consists of a 100pF capacitor charged to the ESD voltage of interest, which is then discharged into the device through a 1.5k Ω resistor.

Driver Output Protection

Two mechanisms prevent excessive output current and power dissipation caused by faults or bus contention. The first, a foldback current limit on the driver output stage, provides immediate protection against short circuits over the whole common-mode voltage range. The second, a thermal shutdown circuit, forces the driver outputs into a high-impedance state if the die temperature exceeds +160°C. Normal operation resumes when the die temperature cools to +140°C, resulting in a pulsed output during continuous short-circuit conditions.

Hot-Swap Capability

Hot-Swap Inputs

Inserting circuit boards into a hot, or powered, backplane may cause voltage transients on DE, \overline{RE} , and receiver inputs A and B that can lead to data errors. For example, upon initial circuit board insertion, the processor undergoes a power-up sequence. During this period, the high-impedance state of the output drivers makes them unable to drive the MAX13442E/MAX13443E/MAX13444E enable inputs to a defined logic level. Meanwhile, leakage currents of up to 10 μ A from the high-impedance output, or capacitively coupled noise from V_{CC} or GND, could cause an input to drift to an incorrect logic state. To prevent such a condition from occurring, the MAX13442E/MAX13443E/MAX13444E feature hot-swap input circuitry on DE, and \overline{RE} to guard against unwanted driver activation during hot-swap situations. The MAX13444E has hot-swap input circuitry only on \overline{RE} . When V_{CC} rises, an internal pulldown (or pullup for \overline{RE}) circuit holds DE low for at least 10 μ s, and until the current into DE exceeds 200 μ A. After the initial power-up sequence, the pulldown circuit becomes transparent, resetting the hot-swap tolerable input.

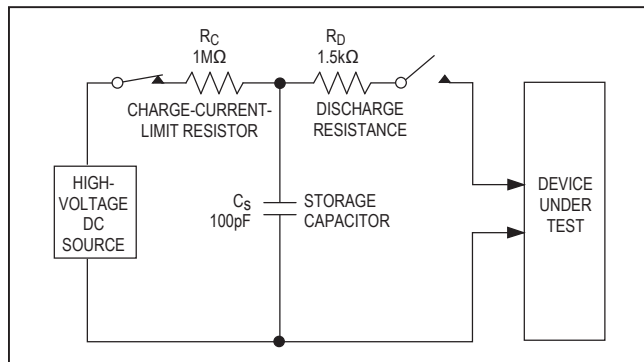

Figure 9a. Human Body ESD Test Model

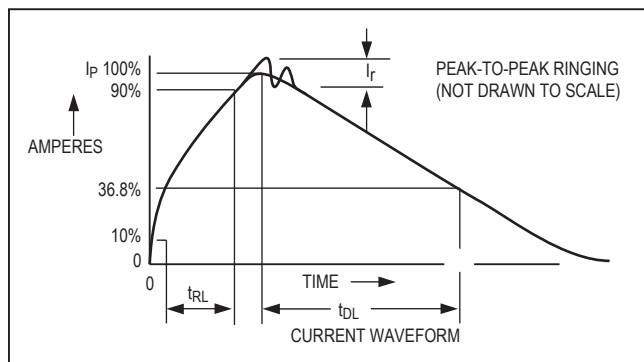

Figure 9b. Human Body Model Current Waveform

Hot-Swap Input Circuitry

At the driver-enable input (DE), there are two NMOS devices, M1 and M2 (Figure 10). When V_{CC} ramps from zero, an internal 15 μ s timer turns on M2 and sets the SR latch, which also turns on M1. Transistors M2, a 2mA current sink, and M1, a 100 μ A current sink, pull DE to GND through a 5.6k Ω resistor. M2 pulls DE to the disabled state against an external parasitic capacitance up to 100pF that may drive DE high. After 15 μ s, the timer deactivates M2 while M1 remains on, holding DE low against three-state leakage currents that may drive DE high. M1 remains on until an external current source overcomes the required input current. At this time, the SR latch resets M1 and turns off. When M1 turns off, DE reverts to a standard, high-impedance CMOS input. Whenever V_{CC} drops below 1V, the input is reset.

A complementary circuit for \overline{RE} uses two PMOS devices to pull \overline{RE} to V_{CC} .

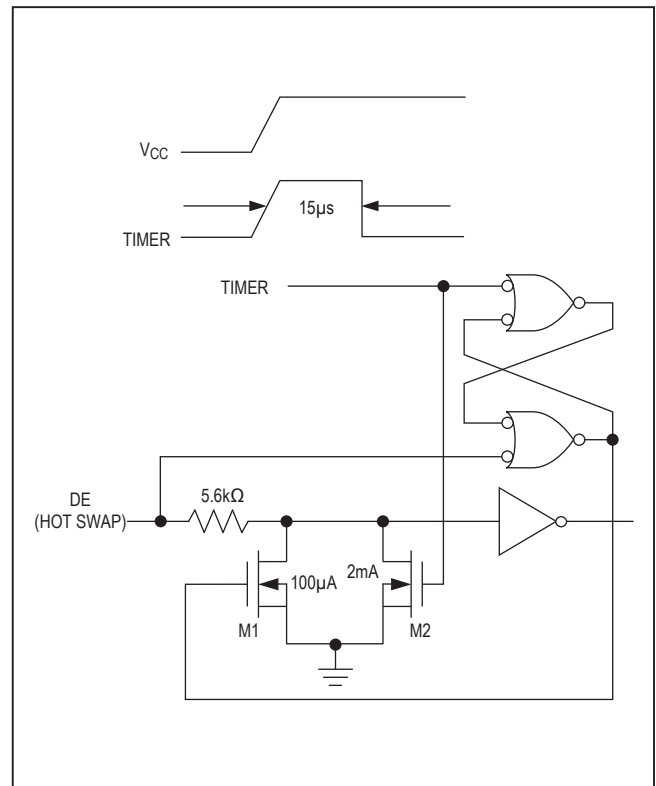

Figure 10. Simplified Structure of the Driver Enable Pin (DE)

Applications Information

128 Transceivers on the Bus

The MAX13442E/MAX13443E/MAX13444E transceivers 1/4-unit-load receiver input impedance (48kΩ) allows up to 128 transceivers connected in parallel on one communication line. Connect any combination of these devices, and/or other RS-485 devices, for a maximum of 32-unit loads to the line.

Reduced EMI and Reflections

The MAX13442E/MAX13444E are slew-rate limited, minimizing EMI and reducing reflections caused by improperly terminated cables. [Figure 11](#) shows the driver output waveform and its Fourier analysis of a 125kHz signal transmitted by a MAX13443E. High-frequency harmonic components with large amplitudes are evident.

[Figure 12](#) shows the same signal displayed for the MAX13442E transmitting under the same conditions. [Figure 12](#)'s high-frequency harmonic components are much lower in amplitude, compared with [Figure 11](#)'s, and the potential for EMI is significantly reduced.

In general, a transmitter's rise time relates directly to the length of an unterminated stub that can be driven with only minor waveform reflections. The following equation expresses this relationship conservatively:

$$\text{length} = t_{\text{RISE}} / (10 \times 1.5\text{ns/ft})$$

where t_{RISE} is the transmitter's rise time.

For example, the MAX13442E's rise time is typically 800ns, which results in excellent waveforms with a stub length up to 53ft. A system can work well with longer unterminated stubs, even with severe reflections, if the waveform settles out before the UART samples them.

RS-485 Applications

The MAX13442E/MAX13443E/MAX13444E transceivers provide bidirectional data communications on multipoint bus transmission lines. [Figure 13](#) shows a typical network application circuit. The RS-485 standard covers line lengths up to 4000ft. To minimize reflections and reduce data errors, terminate the signal line at both ends in its characteristic impedance, and keep stub lengths off the main line as short as possible.

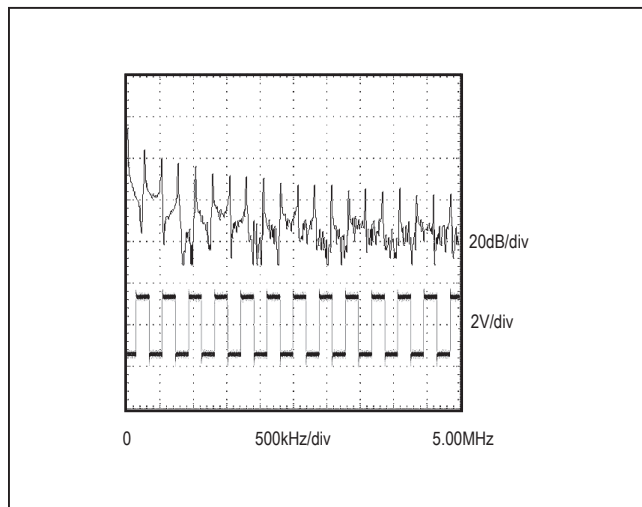

Figure 11. Driver Output Waveform and FFT Plot of the MAX13443E Transmitting a 125kHz Signal

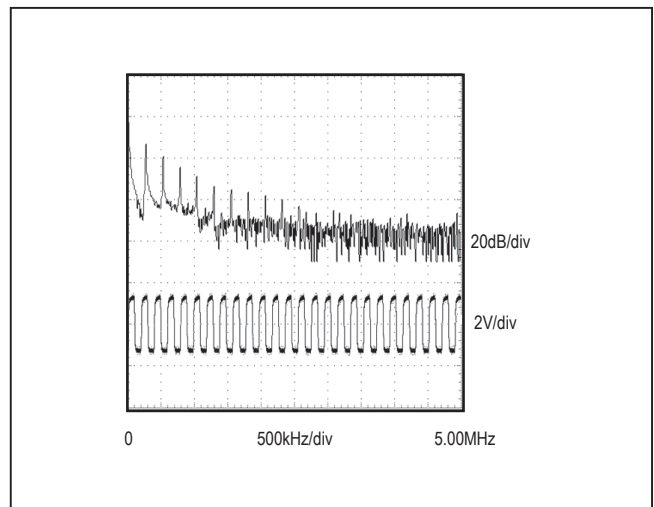

Figure 12. Driver Output Waveform and FFT Plot of the MAX13442E Transmitting a 125kHz Signal

J1708 Applications

The MAX13444E is designed for J1708 applications. To configure the MAX13444E, connect \overline{DE} and \overline{RE} to GND. Connect the signal to be transmitted to TXD. Terminate the bus with the load circuit as shown in Figure 14. The drivers used by SAE J1708 are used in a dominant-mode application. \overline{DE} is active low; a high input on \overline{DE} places the outputs in high impedance. When the driver is disabled (TXD high or \overline{DE} high), the bus is pulled high by external bias resistors R1 and R2. Therefore, a logic-level high is encoded as recessive. When all transceivers are

idle in this configuration, all receivers output logic-high because of the pullup resistor on A and pulldown resistor on B. R1 and R2 provide the bias for the recessive state. C1 and C2 combine to form a lowpass filter, effective for reducing FM interference. R2, C1, R4, and C2 combine to form a 1.6MHz lowpass filter, effective for reducing AM interference. Because the bus is unterminated, at high frequencies, R3 and R4 perform a pseudotermination. This makes the implementation more flexible, as no specific termination nodes are required at the ends of the bus.

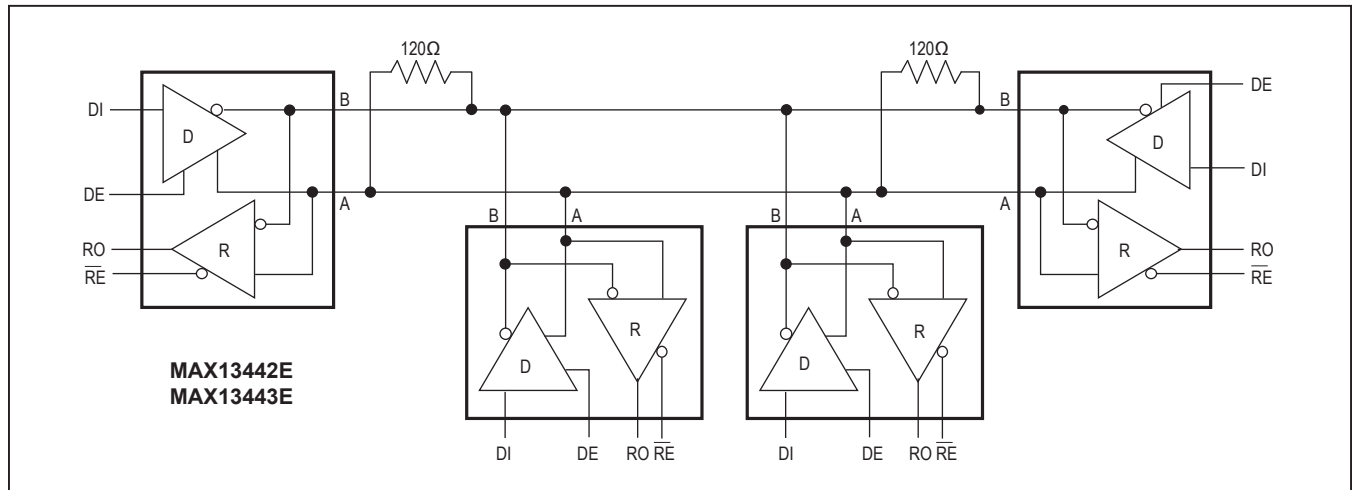

Figure 13. MAX13442E/MAX13443E Typical RS-485 Network

MAX13442E/MAX13443E/
MAX13444E

±15kV ESD-Protected, ±80V Fault-Protected,
Fail-Safe RS-485/J1708 Transceivers

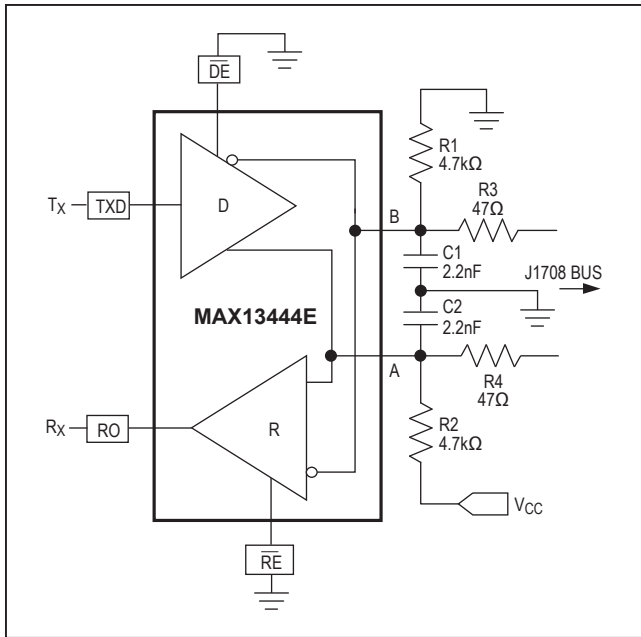

Figure 14. J1708 Application Circuit (See Tables 2 and 4)

Chip Information

PROCESS: BiCMOS

Package Information

For the latest package outline information and land patterns (footprints), go to www.maximintegrated.com/packages. Note that a "+", "#", or "-" in the package code indicates RoHS status only. Package drawings may show a different suffix character, but the drawing pertains to the package regardless of RoHS status.

PACKAGE TYPE	PACKAGE CODE	OUTLINE NO.	LAND PATTERN NO.
8 SO	S8+4	21-0041	90-0096

Pin Configurations and Typical Operating Circuits (continued)

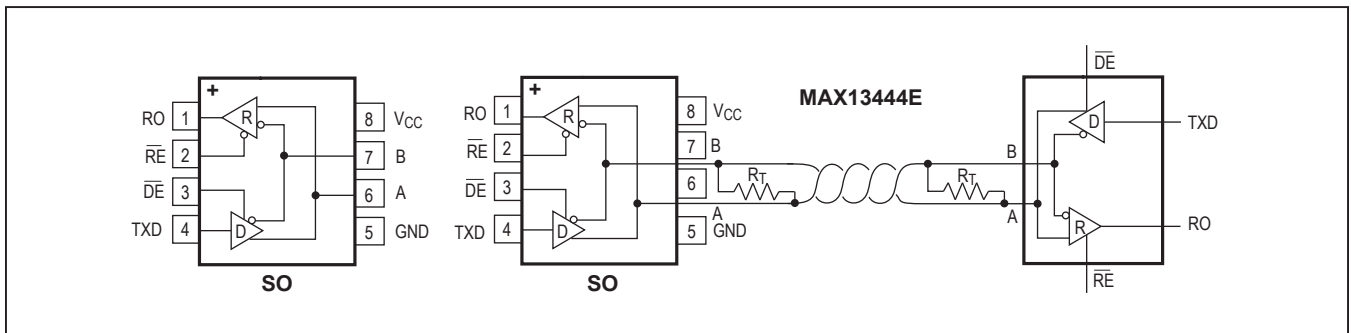

MAX13442E/MAX13443E/
MAX13444E

±15kV ESD-Protected, ±80V Fault-Protected,
Fail-Safe RS-485/J1708 Transceivers

Revision History

REVISION NUMBER	REVISION DATE	DESCRIPTION	PAGES CHANGED
0	10/05	Initial release	—
1	3/06	Corrected the part numbers in the conditions for ΔV_{OC} in the <i>DC Electrical Characteristics</i> table; corrected the A, B current units from mA to FA for the A, B Current vs. A, B Voltage (to Ground) graphs in the <i>Typical Operating Characteristics</i> section	2, 7
2	11/10	Added lead(Pb)-free parts to the Ordering Information table; added the soldering temperature to the <i>Absolute Maximum Ratings</i> section; updated Table 2 outputs	1, 2, 12
3	3/11	Added an automotive qualified part to the <i>Ordering Information</i> ; added the <i>Package Thermal Characteristics</i> section	1, 2

For pricing, delivery, and ordering information, please contact Maxim Direct at 1-888-629-4642, or visit Maxim Integrated's website at www.maximintegrated.com.

Maxim Integrated cannot assume responsibility for use of any circuitry other than circuitry entirely embodied in a Maxim Integrated product. No circuit patent licenses are implied. Maxim Integrated reserves the right to change the circuitry and specifications without notice at any time. The parametric values (min and max limits) shown in the *Electrical Characteristics* table are guaranteed. Other parametric values quoted in this data sheet are provided for guidance.

X-ON Electronics

Largest Supplier of Electrical and Electronic Components

Click to view similar products for [RS-485 Interface IC category](#):

Click to view products by [Maxim manufacturer](#):

Other Similar products are found below :

[LTC1483CN8](#) [LTC1482CN8](#) [SN65HVD1477DGKR](#) [SN65HVD1477DGK](#) [LTC1685CS8#PBF](#) [LTC486CN#PBF](#) [THVD1500DR](#)
[LTC488CSW#PBF](#) [LTC2876HMS8E#PBF](#) [LTC485CS8#PBF](#) [THVD1550DR](#) [LTC1487CN8#PBF](#) [LTC489CSW#PBF](#) [LTC1485CN8#PBF](#)
[LTC1686IS8#PBF](#) [LTC488CN#PBF](#) [LTC1480IN8#PBF](#) [ADM3066EARMZ](#) [ADM3095EBRZ](#) [LTC487IN#PBF](#) [LTC1482CMS8#PBF](#)
[LTC488IN#PBF](#) [LTC486IN#PBF](#) [LTC1481IN8#PBF](#) [SN65HVD1470DR](#) [ADM3063EARZ](#) [ADM3068EARZ](#) [ADM3064EARZ-R7](#)
[ADM3064EBRZ](#) [ADM3064EARZ](#) [ADM3065ETRMZ-EP](#) [ADM3066EBRMZ-R7](#) [ADM3066ETRMZ-EP](#) [ADM3095EARZ](#) [LTC1687IS#PBF](#)
[LTC1686CS8#PBF](#) [LTC1481CS8#PBF](#) [LTC1485IS8#TRPBF](#) [LTC1482CS8#TRPBF](#) [LTC485CN8#PBF](#) [SP488CS](#) [LTC1484CN8#PBF](#)
[LTC1482CN8#PBF](#) [LTC1483IN8#PBF](#) [LTC1483CS8](#) [LTC1483IS8](#) [LTC1485IS8](#) [LTC1518IS](#) [LTC1689IS#PBF](#) [LTC2859IDD](#)