

# MAX14575A–MAX14575C Evaluation Kits

# Evaluate: MAX14575A/MAX14575AL/ MAX14575B/MAX14575C

## General Description

The MAX14575A–MAX14575C evaluation kits (EV kits) are fully assembled and tested circuit boards that demonstrate the functionality of the MAX14575A–MAX14575C adjustable current-limit switches in an 8-pin TDFN package. Each EV kit features jumpers for configuration and evaluation of all versions of the IC, which include autoretry, latching, and continuous current-limit versions. Input power to the EV kits is provided by a standard 5V USB bus or an external 5V power supply.

## Benefits and Features

- Evaluate Preselected Threshold or Adjustable Threshold by Simple Jumper Configuration
- Easy Connections through Binding Posts
- Status LEDs Give Visual Indication of Power Present and Fault Conditions
- Proven PCB Layout
- Fully Assembled and Tested

[Ordering Information](#) appears at end of data sheet.

## Component List

| DESIGNATION             | QTY | DESCRIPTION  |
|-------------------------|-----|--|
| BP1, BP3                | 2   | Red binding posts<br>Keystone 7006   |
| BP2, BP4                | 2   | Black binding posts<br>Keystone 7007   |
| C1                      | 1   | 1 $\mu$ F $\pm$ 10%, 25V X5R ceramic capacitor (0603)<br>Murata GRM188R61E105K   |
| C2                      | 1   | 0.1 $\mu$ F $\pm$ 10%, 25V X5R ceramic capacitor (0603)<br>Murata GRM188R61E104K |
| C3, C4                  | 2   | 10 $\mu$ F $\pm$ 10%, 25V X5R ceramic capacitors (0805)<br>TDK C2012X5R1E106K    |
| J1                      | 1   | USB type-B right-angle receptacle<br>Molex 67068-9000                            |
| JU1                     | 1   | 8-pin, dual-row header,<br>0.1in centers   |
| JU2, JU5,<br>JU10, JU11 | 4   | 2-pin, single-row headers,<br>0.1in centers                                      |
| JU3                     | 1   | 4-pin header, 0.1in centers  |
| LED1                    | 1   | Green LED (1206)<br>Kingbright APTL3216CGCK                                      |

| DESIGNATION           | QTY | DESCRIPTION   |
|-----------------------|-----|---|
| LED2                  | 1   | Red LED (1206)<br>Lite-On LTST-C150CKT                        |
| R1                    | 1   | 309 $\Omega$ $\pm$ 1% resistor (0805)                         |
| R2                    | 1   | 10k $\Omega$ $\pm$ 1% resistor (0805)                         |
| R3                    | 1   | 332 $\Omega$ $\pm$ 1% resistor (0805)                         |
| R4, R9, R11           | 3   | 475k $\Omega$ $\pm$ 1% resistors (0805)                       |
| R5, R12               | 0   | Not installed, resistors (0805)                               |
| R6                    | 1   | 499k $\Omega$ $\pm$ 1% resistor (0805)                        |
| R7                    | 1   | 84.5k $\Omega$ $\pm$ 1% resistor (0805)                       |
| R8, R15               | 2   | 51.1k $\Omega$ $\pm$ 1% resistors (0805)                      |
| R10                   | 1   | 1k $\Omega$ $\pm$ 1% resistor (0805)                          |
| R16                   | 1   | 12-turn, 500k $\Omega$ potentiometer<br>Murata PV37W504C01B00 |
| TP1                   | 1   | White test point  |
| TP2, TP4,<br>TP5, TP7 | 4   | Black test points   |
| TP3, TP6              | 2   | Red test points   |
| TP8                   | 1   | Yellow test point   |
| U1                    | 1   | See the <i>EV Kit-Specific Component List</i>                 |
| U2                    | 1   | NC7WZ07   |
| —                     | 5   | Shunts  |
| —                     | 1   | PCB: MAX14575A/B/C EVKIT                                      |

## EV Kit-Specific Component List

| PART            | DESIGNATION | DESCRIPTION   |
|-----------------|-------------|---|
| MAX14575AEVKIT# | U1*         | 250mA to 2.5A adjustable current-limit switch (8 TDFN-EP**)<br>Maxim MAX14575AETA+<br>(Top Mark: BMV) |
| MAX14575BEVKIT# |             | 250mA to 2.5A adjustable current-limit switch (8 TDFN-EP**)<br>Maxim MAX14575BETA+<br>(Top Mark: BMX) |
| MAX14575CEVKIT# |             | 250mA to 2.5A adjustable current-limit switch (8 TDFN-EP**)<br>Maxim MAX14575CETA+<br>(Top Mark: BMY) |

\*For evaluation of the MAX14575AL, samples must be ordered separately and installed in place of U1 by the customer.

\*\*EP = Exposed pad.

## Component Suppliers

| SUPPLIER                   | PHONE        | WEBSITE                |
|----------------------------|--------------|------------------------|
| Keystone Electronics Corp. | 800-221-5510 | www.keyelco.com        |
| Kingbright Corporation     | 909-468-0500 | www.kingbrightusa.com  |
| Lite-On, Inc.              | 408-946-4873 | www.us.liteon.com      |
| Molex                      | 800-786-6539 | www.molex.com          |
| Murata Americas            | 800-241-6574 | www.murataamericas.com |
| TDK Corp.                  | 847-803-6100 | www.component.tdk.com  |

**Note:** Indicate that you are using the MAX14575A–MAX14575C when contacting these component suppliers.

## Quick Start

### Required Equipment

- MAX14575A–MAX14575C EV kit
- 5V, 2.6A power supply

### Procedure

The EV kits are fully assembled and tested. Follow the steps below to verify board operation:

- 1) Verify that a shunt is installed across pins 1-3 on jumper JU3 (powers the device and peripherals at TP6) and that a shunt is installed across pins 1-2 on jumper JU5 (enables the device).
- 2) Verify that a shunt is installed across pins 1-2 on jumper JU10 (connects the FLAG output on the device to LED).
- 3) Verify that a shunt is not installed across pins 1-2 on jumper JU2 (an installed jumper forces LED2 on).
- 4) Install a shunt at the desired location on jumper JU1 to set the current limit according to Table 1.
- 5) Connect the 5V, 2.6A power supply at TP6.
- 6) Verify that the green LED (LED1) is lit, indicating that the device is powered.

7) Connect TP8 or BP3 to the system in which the device will be evaluated, or connect a variable load to TP8.

8) If current limit is reached, LED2 glows red and device goes into its defined overcurrent fault response. See the MAX14575A/MAX14575AL/MAX14575B/MAX14575C IC data sheet for more details.

## Detailed Description of Hardware

The MAX14575A–MAX14575C EV kits are fully assembled and tested circuit boards that demonstrate the functionality of the MAX14575A–MAX14575C adjustable current-limit switches in an 8-pin TDFN package. Each EV kit features jumpers for configuration and evaluation of all versions of the device, which include autoretry, latching, and continuous current-limit versions. Input power to the EV kit is provided by a standard 5V USB bus or an external 5V power supply. Included with the EV kit is a USB type-A male to USB type-B male cable, providing a convenient way to power the EV kit's peripherals without disturbing evaluation of the current-limiting function of the device. Input power can also be supplied by an external DC source.

### Power Supply

The EV kit peripherals are powered by a user-supplied USB port at J1 or by a 5V DC power supply connected between  $V_{EXT}$  and GND. Jumper JU3's position selects the power source. With a shunt shorting pins 1-2 on JU3, the EV kit is powered at  $V_{EXT}$ , while a shunt shorting pins 1-3 means that the EV kit is powered by the supply present at the input of the device. Placing the shunt on pins 1-4 on JU3 allows the peripheral devices to be powered from an external power supply connected at TP3. The device must always be powered by an external supply connected at TP6 or BP1. See Table 1 for jumper settings.

### Flag Indicator LED

The EV kit includes a built-in LED to give visual notification of an overcurrent fault. If jumper JU10 has a shunt

installed at 1-2 and jumper JU2 has no shunt installed, then an overcurrent fault causes LED2 to glow red. See Table 1 for jumper settings.

### Preset and Adjustable Current Limits

The EV kit includes three common overcurrent limits as jumper-configurable options, as well as a fourth jumper-configurable option for an adjustable limit. Set the current limit to 250mA and install a shunt across pins 1-2 on jumper JU1. For the 1.5A current limit, install a shunt across pins 3-4 on JU1. For the 2.5A current limit or the adjustable limit, install a shunt across pins 5-6 or 7-8 on JU1, respectively. The adjustable limit is set using the potentiometer (R16). See Table 1 for jumper settings.

**Table 1. Jumper Settings (JU1–JU3, JU5, JU10, JU11)**

| JUMPER | SHUNT POSITION | DESCRIPTION  |
|--------|----------------|--|
| JU1    | 1-2            | 250mA current limit                                      |
|        | 3-4*           | 1.5A current limit                                       |
|        | 5-6            | 2.5A current limit                                       |
|        | 7-8            | Adjustable current limit (adjust current limit with R16) |
| JU2    | 1-2            | Force flag   |
|        | Not installed* | Normal operation   |
| JU3    | 1-2*           | Peripherals are powered by USB (J1)                      |
|        | 1-3            | Peripherals are powered by the same supply as the device |
|        | 1-4            | Peripherals are powered by an external 5V supply         |
| JU5    | 1-2*           | Enables the device                                       |
|        | Not installed  | Disables the device                                      |
| JU10   | 1-2*           | Enables the fault indicator LED (LED2)                   |
|        | Not Installed  | Disables the fault indicator LED (LED2)                  |
| JU11   | 1-2            | Shorts input and output of the device                    |
|        | Not installed* | Normal operation   |

\*Default position.

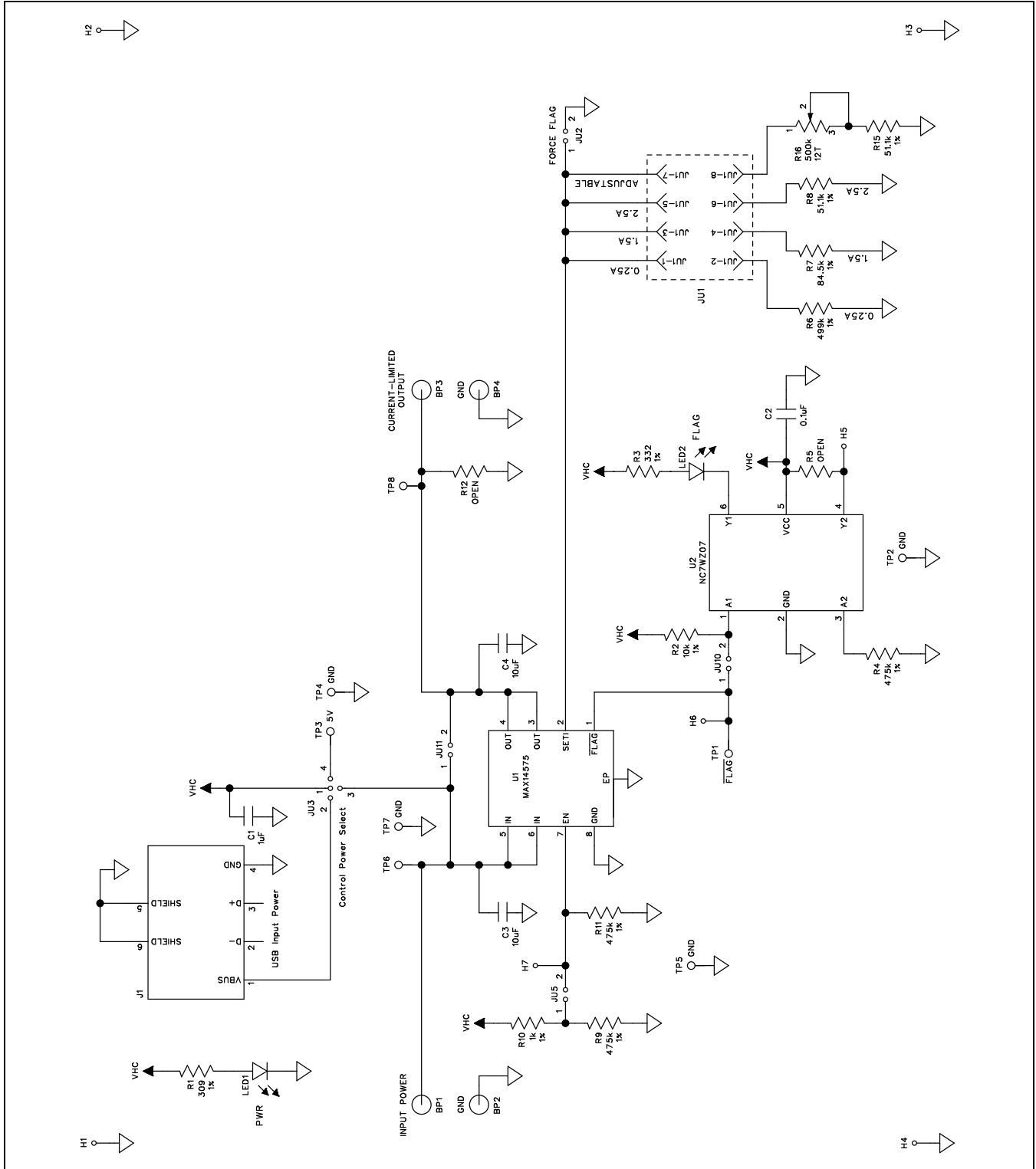

Figure 1. MAX14575A–MAX14575C EV Kit Schematic

MAX14575A–MAX14575C  
Evaluation Kits

Evaluate: MAX14575A/MAX14575AL/  
MAX14575B/MAX14575C

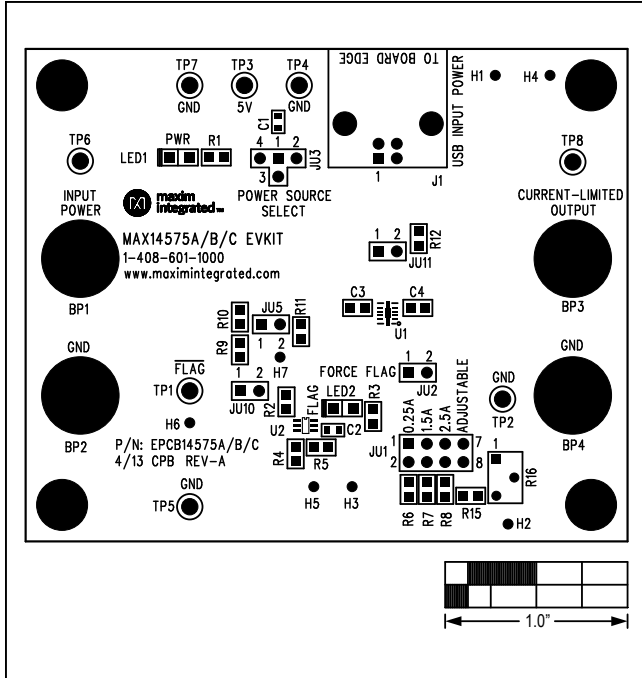

Figure 2. MAX14575A–MAX14575C EV Kit Component Placement Guide—Component Side

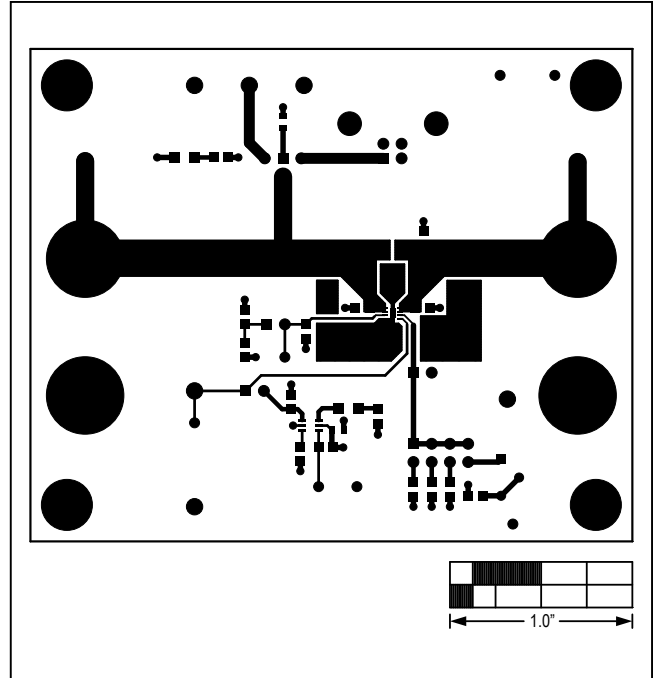

Figure 3. MAX14575A–MAX14575C EV Kit PCB Layout—Component Side

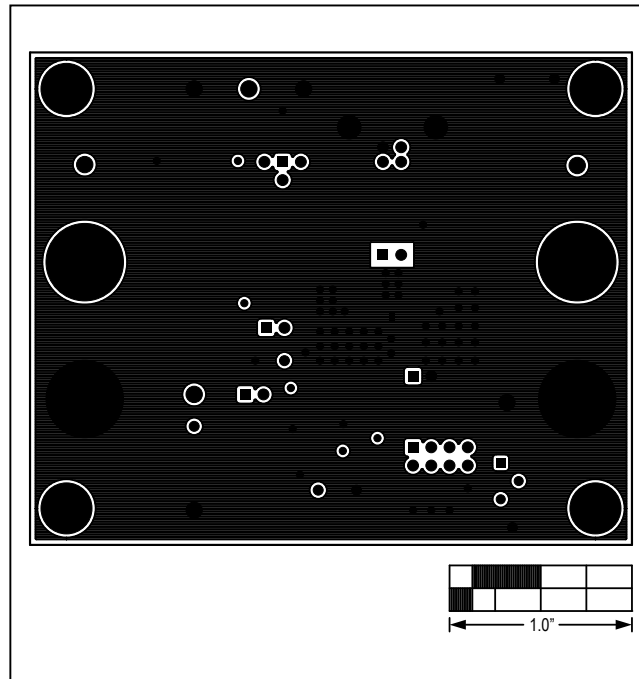

Figure 4. MAX14575A–MAX14575C EV Kit PCB Layout—Layer 2

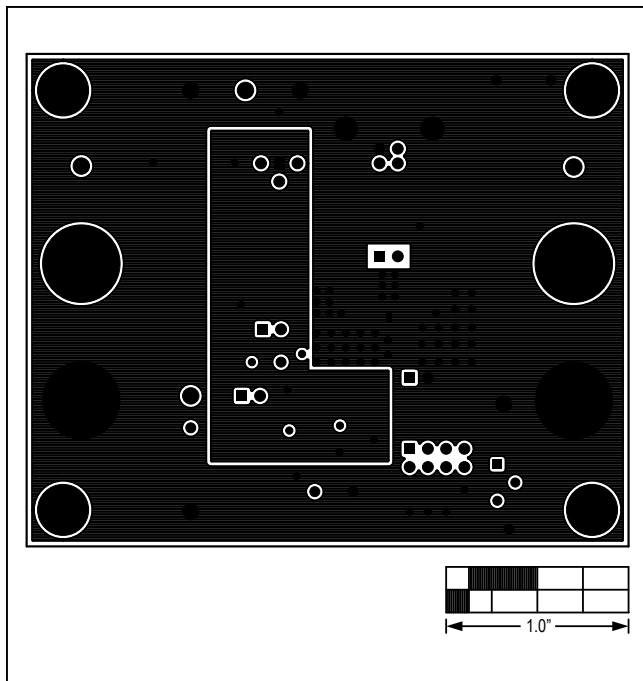

Figure 5. MAX14575A–MAX14575C EV Kit PCB Layout—  
Layer 3

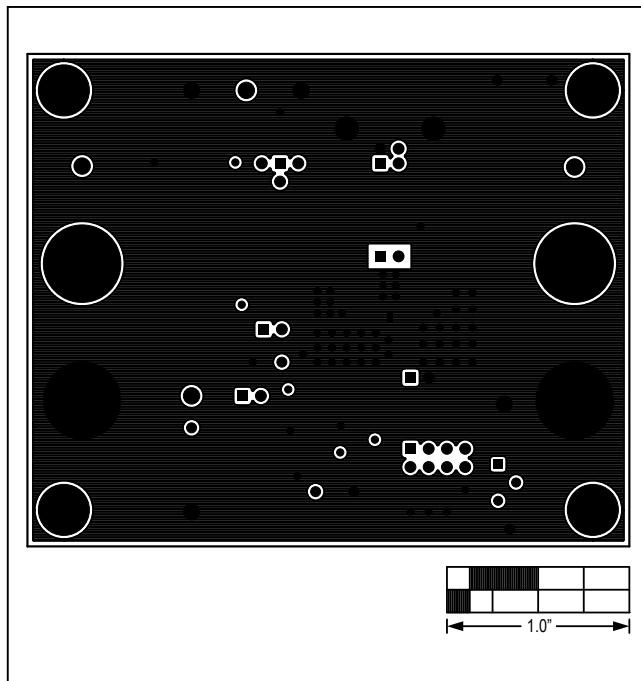

Figure 6. MAX14575A–MAX14575C EV Kit PCB Layout—  
Solder Side

---

MAX14575A–MAX14575C  
Evaluation Kits

Evaluate: MAX14575A/MAX14575AL/  
MAX14575B/MAX14575C

## Ordering Information

| PART            | TYPE   |
|-----------------|--------|
| MAX14575AEVKIT# | EV Kit |
| MAX14575BEVKIT# | EV Kit |
| MAX14575CEVKIT# | EV Kit |

#Denotes RoHS compliant.

MAX14575A–MAX14575C  
Evaluation Kits

Evaluate: MAX14575A/MAX14575AL/  
MAX14575B/MAX14575C

## Revision History

| REVISION NUMBER | REVISION DATE | DESCRIPTION     | PAGES CHANGED |
|-----------------|---------------|-----------------|---------------|
| 0               | 5/13          | Initial release | —             |

For pricing, delivery, and ordering information, please contact Maxim Direct at 1-888-629-4642, or visit Maxim Integrated's website at [www.maximintegrated.com](http://www.maximintegrated.com).

*Maxim Integrated cannot assume responsibility for use of any circuitry other than circuitry entirely embodied in a Maxim Integrated product. No circuit patent licenses are implied. Maxim Integrated reserves the right to change the circuitry and specifications without notice at any time.*



## X-ON Electronics

Largest Supplier of Electrical and Electronic Components

*Click to view similar products for [Switch IC Development Tools](#) category:*

*Click to view products by [Maxim](#) manufacturer:*

Other Similar products are found below :

[EVAL-8MSOPEBZ](#) [ISL54059EVAL1Z](#) [TPS2041BEVM](#) [TPS2041BEVM-292](#) [TPS2051BEVM](#) [BOB-09056](#) [EKIT01-HMC1027BG](#)  
[TPS2561DRCEVM-424](#) [2717](#) [ISL54220IRUEVAL1Z](#) [TS3USB221AEVM](#) [ASL1101](#) [SIP32102EVB](#) [EVAL-14TSSOPEBZ](#) [EVAL-](#)  
[16TSSOPEBZ](#) [EVAL-ADG5243FEBZ](#) [EVAL-ADG5248FEBZ](#) [EVAL-ADG5249FEBZ](#) [EVAL-ADG5298EB1Z](#) [EVAL-ADG5412BFEBZ](#)  
[EVAL-ADG5412FEBZ](#) [EVAL-ADG5436FEBZ](#) [EVAL-ADG5462FEBZ](#) [EVAL-ADG788EBZ](#) [EVAL-ADG854EBZ](#) [EVAL-ADG884EBZ](#)  
[EVAL-ADG888EBZ](#) [EVAL-ADGS1412SDZ](#) [DFR0576](#) [DG1208EVKIT#](#) [DG1209EVKIT#](#) [MAX20334EVKIT#](#) [ADM00393](#) [ADM00795](#)  
[ADM00825](#) [MIC95410YFL-EV](#) [MIKROE-3916](#) [MIKROE-4094](#) [MIKROE-4111](#) [MIKROE-4240](#) [MIKROE-1998](#) [MIKROE-3245](#) [MIKROE-](#)  
[3247](#) [MIKROE-3262](#) [FSUSB242GEVB](#) [FUSB252GEVB](#) [TPS22932BEVM](#) [TPS2511EVM-141](#) [TS3DDR4000-EVM](#) [ADM00669](#)