

MAX14575A–MAX14575C Evaluation Kits

Evaluate: MAX14575A/MAX14575AL/ MAX14575B/MAX14575C

General Description

The MAX14575A–MAX14575C evaluation kits (EV kits) are fully assembled and tested circuit boards that demonstrate the functionality of the MAX14575A–MAX14575C adjustable current-limit switches in an 8-pin TDFN package. Each EV kit features jumpers for configuration and evaluation of all versions of the IC, which include autoretry, latching, and continuous current-limit versions. Input power to the EV kits is provided by a standard 5V USB bus or an external 5V power supply.

Benefits and Features

- Evaluate Preselected Threshold or Adjustable Threshold by Simple Jumper Configuration
- Easy Connections through Binding Posts
- Status LEDs Give Visual Indication of Power Present and Fault Conditions
- Proven PCB Layout
- Fully Assembled and Tested

[Ordering Information](#) appears at end of data sheet.

Component List

DESIGNATION	QTY	DESCRIPTION
BP1, BP3	2	Red binding posts Keystone 7006
BP2, BP4	2	Black binding posts Keystone 7007
C1	1	1 μ F \pm 10%, 25V X5R ceramic capacitor (0603) Murata GRM188R61E105K
C2	1	0.1 μ F \pm 10%, 25V X5R ceramic capacitor (0603) Murata GRM188R61E104K
C3, C4	2	10 μ F \pm 10%, 25V X5R ceramic capacitors (0805) TDK C2012X5R1E106K
J1	1	USB type-B right-angle receptacle Molex 67068-9000
JU1	1	8-pin, dual-row header, 0.1in centers
JU2, JU5, JU10, JU11	4	2-pin, single-row headers, 0.1in centers
JU3	1	4-pin header, 0.1in centers
LED1	1	Green LED (1206) Kingbright APTL3216CGCK

DESIGNATION	QTY	DESCRIPTION
LED2	1	Red LED (1206) Lite-On LTST-C150CKT
R1	1	309 Ω \pm 1% resistor (0805)
R2	1	10k Ω \pm 1% resistor (0805)
R3	1	332 Ω \pm 1% resistor (0805)
R4, R9, R11	3	475k Ω \pm 1% resistors (0805)
R5, R12	0	Not installed, resistors (0805)
R6	1	499k Ω \pm 1% resistor (0805)
R7	1	84.5k Ω \pm 1% resistor (0805)
R8, R15	2	51.1k Ω \pm 1% resistors (0805)
R10	1	1k Ω \pm 1% resistor (0805)
R16	1	12-turn, 500k Ω potentiometer Murata PV37W504C01B00
TP1	1	White test point
TP2, TP4, TP5, TP7	4	Black test points
TP3, TP6	2	Red test points
TP8	1	Yellow test point
U1	1	See the <i>EV Kit-Specific Component List</i>
U2	1	NC7WZ07
—	5	Shunts
—	1	PCB: MAX14575A/B/C EVKIT

EV Kit-Specific Component List

PART	DESIGNATION	DESCRIPTION
MAX14575AEVKIT#	U1*	250mA to 2.5A adjustable current-limit switch (8 TDFN-EP**) Maxim MAX14575AETA+ (Top Mark: BMV)
MAX14575BEVKIT#		250mA to 2.5A adjustable current-limit switch (8 TDFN-EP**) Maxim MAX14575BETA+ (Top Mark: BMX)
MAX14575CEVKIT#		250mA to 2.5A adjustable current-limit switch (8 TDFN-EP**) Maxim MAX14575CETA+ (Top Mark: BMY)

*For evaluation of the MAX14575AL, samples must be ordered separately and installed in place of U1 by the customer.

**EP = Exposed pad.

Component Suppliers

SUPPLIER	PHONE	WEBSITE
Keystone Electronics Corp.	800-221-5510	www.keyelco.com
Kingbright Corporation	909-468-0500	www.kingbrightusa.com
Lite-On, Inc.	408-946-4873	www.us.liteon.com
Molex	800-786-6539	www.molex.com
Murata Americas	800-241-6574	www.murataamericas.com
TDK Corp.	847-803-6100	www.component.tdk.com

Note: Indicate that you are using the MAX14575A–MAX14575C when contacting these component suppliers.

Quick Start

Required Equipment

- MAX14575A–MAX14575C EV kit
- 5V, 2.6A power supply

Procedure

The EV kits are fully assembled and tested. Follow the steps below to verify board operation:

- 1) Verify that a shunt is installed across pins 1-3 on jumper JU3 (powers the device and peripherals at TP6) and that a shunt is installed across pins 1-2 on jumper JU5 (enables the device).
- 2) Verify that a shunt is installed across pins 1-2 on jumper JU10 (connects the FLAG output on the device to LED).
- 3) Verify that a shunt is not installed across pins 1-2 on jumper JU2 (an installed jumper forces LED2 on).
- 4) Install a shunt at the desired location on jumper JU1 to set the current limit according to Table 1.
- 5) Connect the 5V, 2.6A power supply at TP6.
- 6) Verify that the green LED (LED1) is lit, indicating that the device is powered.

7) Connect TP8 or BP3 to the system in which the device will be evaluated, or connect a variable load to TP8.

8) If current limit is reached, LED2 glows red and device goes into its defined overcurrent fault response. See the MAX14575A/MAX14575AL/MAX14575B/MAX14575C IC data sheet for more details.

Detailed Description of Hardware

The MAX14575A–MAX14575C EV kits are fully assembled and tested circuit boards that demonstrate the functionality of the MAX14575A–MAX14575C adjustable current-limit switches in an 8-pin TDFN package. Each EV kit features jumpers for configuration and evaluation of all versions of the device, which include autoretry, latching, and continuous current-limit versions. Input power to the EV kit is provided by a standard 5V USB bus or an external 5V power supply. Included with the EV kit is a USB type-A male to USB type-B male cable, providing a convenient way to power the EV kit's peripherals without disturbing evaluation of the current-limiting function of the device. Input power can also be supplied by an external DC source.

Power Supply

The EV kit peripherals are powered by a user-supplied USB port at J1 or by a 5V DC power supply connected between V_{EXT} and GND. Jumper JU3's position selects the power source. With a shunt shorting pins 1-2 on JU3, the EV kit is powered at V_{EXT} , while a shunt shorting pins 1-3 means that the EV kit is powered by the supply present at the input of the device. Placing the shunt on pins 1-4 on JU3 allows the peripheral devices to be powered from an external power supply connected at TP3. The device must always be powered by an external supply connected at TP6 or BP1. See Table 1 for jumper settings.

Flag Indicator LED

The EV kit includes a built-in LED to give visual notification of an overcurrent fault. If jumper JU10 has a shunt

installed at 1-2 and jumper JU2 has no shunt installed, then an overcurrent fault causes LED2 to glow red. See Table 1 for jumper settings.

Preset and Adjustable Current Limits

The EV kit includes three common overcurrent limits as jumper-configurable options, as well as a fourth jumper-configurable option for an adjustable limit. Set the current limit to 250mA and install a shunt across pins 1-2 on jumper JU1. For the 1.5A current limit, install a shunt across pins 3-4 on JU1. For the 2.5A current limit or the adjustable limit, install a shunt across pins 5-6 or 7-8 on JU1, respectively. The adjustable limit is set using the potentiometer (R16). See Table 1 for jumper settings.

Table 1. Jumper Settings (JU1–JU3, JU5, JU10, JU11)

JUMPER	SHUNT POSITION	DESCRIPTION
JU1	1-2	250mA current limit
	3-4*	1.5A current limit
	5-6	2.5A current limit
	7-8	Adjustable current limit (adjust current limit with R16)
JU2	1-2	Force flag
	Not installed*	Normal operation
JU3	1-2*	Peripherals are powered by USB (J1)
	1-3	Peripherals are powered by the same supply as the device
	1-4	Peripherals are powered by an external 5V supply
JU5	1-2*	Enables the device
	Not installed	Disables the device
JU10	1-2*	Enables the fault indicator LED (LED2)
	Not Installed	Disables the fault indicator LED (LED2)
JU11	1-2	Shorts input and output of the device
	Not installed*	Normal operation

*Default position.

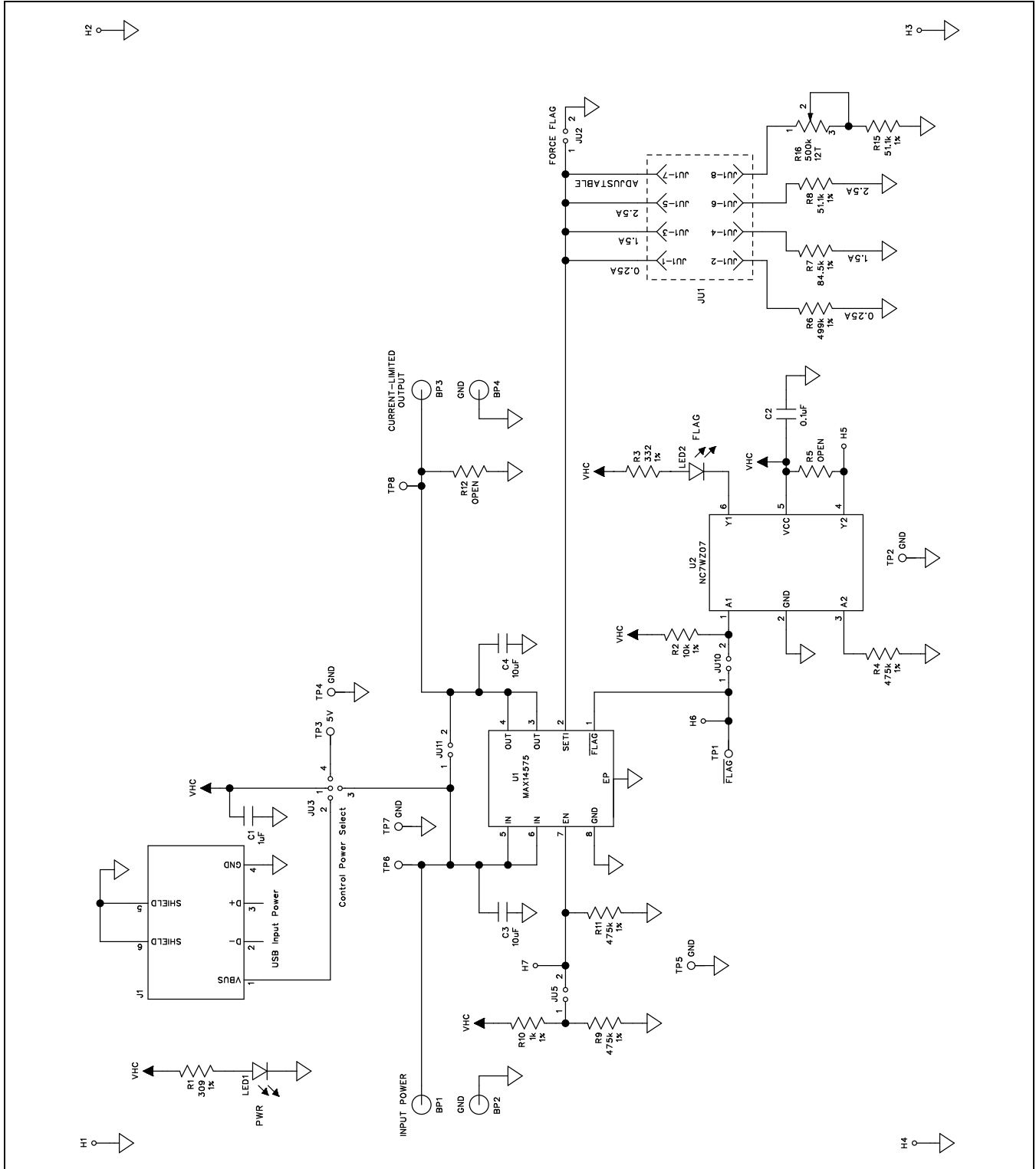

Figure 1. MAX14575A–MAX14575C EV Kit Schematic

MAX14575A–MAX14575C Evaluation Kits

Evaluate: MAX14575A/MAX14575AL/ MAX14575B/MAX14575C

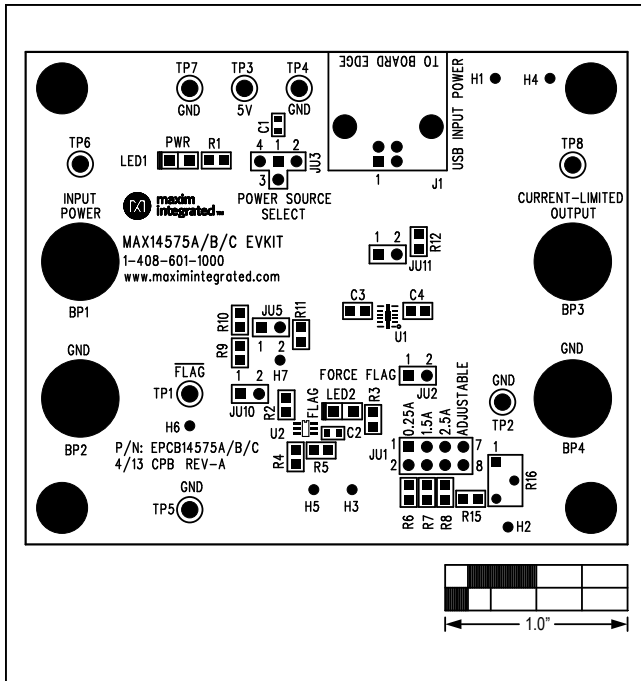

Figure 2. MAX14575A–MAX14575C EV Kit Component Placement Guide—Component Side

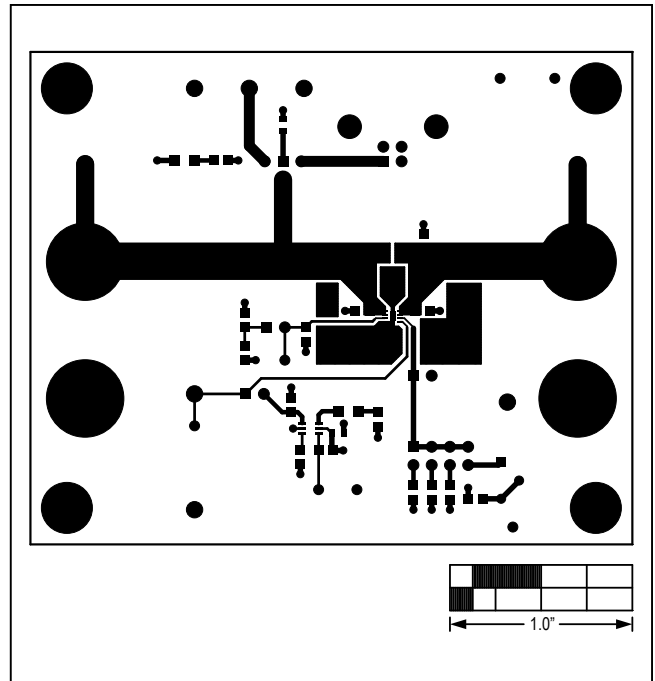

Figure 3. MAX14575A–MAX14575C EV Kit PCB Layout—Component Side

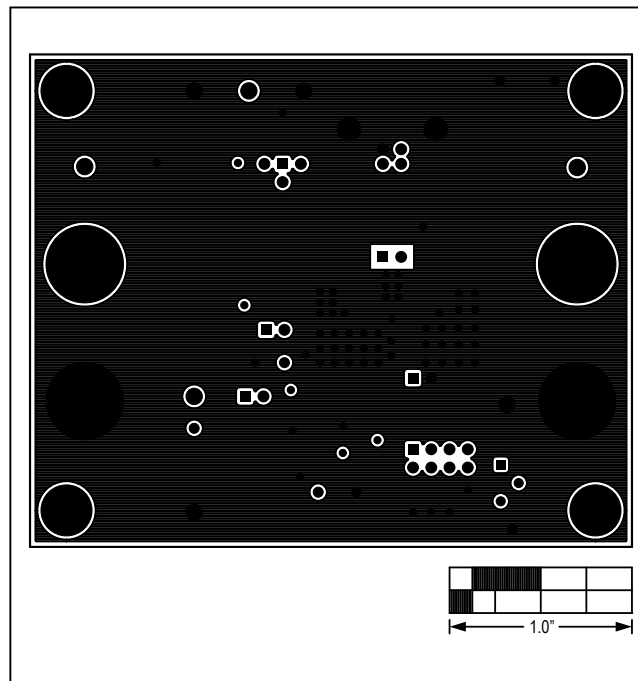

Figure 4. MAX14575A–MAX14575C EV Kit PCB Layout—Layer 2

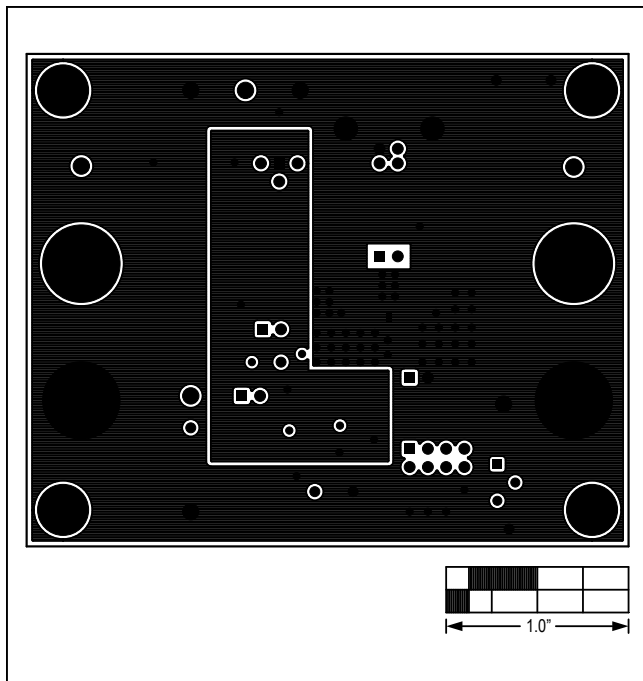

Figure 5. MAX14575A–MAX14575C EV Kit PCB Layout—
Layer 3

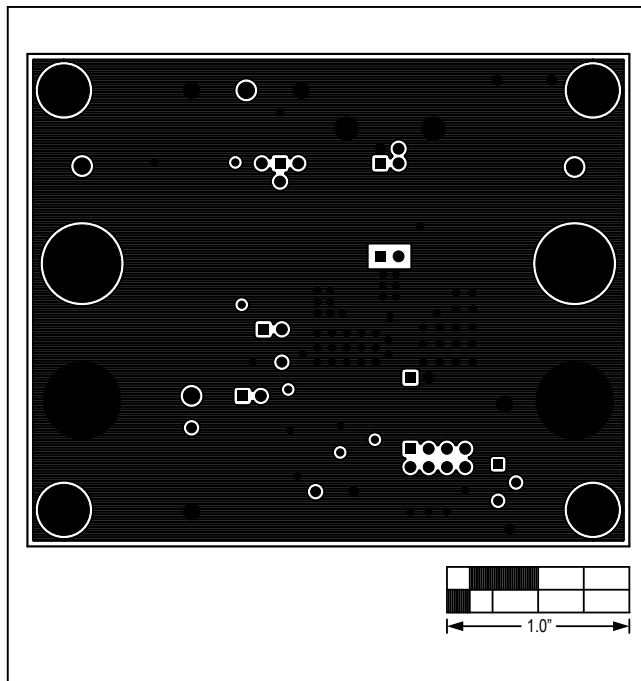

Figure 6. MAX14575A–MAX14575C EV Kit PCB Layout—
Solder Side

MAX14575A–MAX14575C
Evaluation Kits

Evaluate: MAX14575A/MAX14575AL/
MAX14575B/MAX14575C

Ordering Information

PART	TYPE
MAX14575AEVKIT#	EV Kit
MAX14575BEVKIT#	EV Kit
MAX14575CEVKIT#	EV Kit

#Denotes RoHS compliant.

MAX14575A–MAX14575C
Evaluation Kits

Evaluate: MAX14575A/MAX14575AL/
MAX14575B/MAX14575C

Revision History

REVISION NUMBER	REVISION DATE	DESCRIPTION	PAGES CHANGED
0	5/13	Initial release	—

For pricing, delivery, and ordering information, please contact Maxim Direct at 1-888-629-4642, or visit Maxim Integrated's website at www.maximintegrated.com.

Maxim Integrated cannot assume responsibility for use of any circuitry other than circuitry entirely embodied in a Maxim Integrated product. No circuit patent licenses are implied. Maxim Integrated reserves the right to change the circuitry and specifications without notice at any time.

X-ON Electronics

Largest Supplier of Electrical and Electronic Components

Click to view similar products for [Power Management IC Development Tools](#) category:

Click to view products by [Maxim](#) manufacturer:

Other Similar products are found below :

[EVB-EP5348UI](#) [MIC23451-AAAYFL EV](#) [MIC5281YMME EV](#) [124352-HMC860LP3E](#) [DA9063-EVAL](#) [ADP122-3.3-EVALZ](#) [ADP130-0.8-EVALZ](#) [ADP130-1.8-EVALZ](#) [ADP1740-1.5-EVALZ](#) [ADP1870-0.3-EVALZ](#) [ADP1874-0.3-EVALZ](#) [ADP199CB-EVALZ](#) [ADP2102-1.25-EVALZ](#) [ADP2102-1.875EVALZ](#) [ADP2102-1.8-EVALZ](#) [ADP2102-2-EVALZ](#) [ADP2102-3-EVALZ](#) [ADP2102-4-EVALZ](#) [AS3606-DB](#) [BQ25010EVM](#) [BQ3055EVM](#) [ISLUSBI2CKIT1Z](#) [LP38512TS-1.8EV](#) [EVAL-ADM1186-1MBZ](#) [EVAL-ADM1186-2MBZ](#) [ADP122UJZ-REDYKIT](#) [ADP166Z-REDYKIT](#) [ADP170-1.8-EVALZ](#) [ADP171-EVALZ](#) [ADP1853-EVALZ](#) [ADP1873-0.3-EVALZ](#) [ADP198CP-EVALZ](#) [ADP2102-1.0-EVALZ](#) [ADP2102-1-EVALZ](#) [ADP2107-1.8-EVALZ](#) [ADP5020CP-EVALZ](#) [CC-ACC-DBMX-51](#) [ATPL230A-EK](#) [MIC23250-S4YMT EV](#) [MIC26603YJL EV](#) [MIC33050-SYHL EV](#) [TPS60100EVM-131](#) [TPS65010EVM-230](#) [TPS71933-28EVM-213](#) [TPS72728YFFEVM-407](#) [TPS79318YEQEVM](#) [UCC28810EVM-002](#) [XILINXPWR-083](#) [LMR22007YMINI-EVM](#) [LP38501ATJ-EV](#)