

General Description

The MAX14827 evaluation kit (EV kit) consists of a MAX14827 evaluation board is a fully assembled and tested circuit board that evaluates the MAX14827 IO-Link® device transceiver.

The EV kit is designed to operate as a stand-alone board or with an mbed® board for easy software evaluation.

The MAX14827 EV kit can also be used to evaluate the MAX14827A.

Features

- IO-Link-Compliant Device Transceiver
- IO and SPI Interface Terminals
- Proven PCB Layout
- Fully Assembled and Tested

[Ordering Information](#) appears at end of data sheet.

Quick Start

Recommended Equipment

- MAX14827 EV kit
- 24V, 500mA DC power supply
- Function generator or logic signal generator
- Oscilloscope

Procedure

The EV kit is fully assembled and tested. Follow the steps below to verify board operation before exercising the full features of the device:

- 1) Verify that all the jumpers are in their default positions, as shown in [Table 1](#). Ensure that SW1 is to the left (using the internal 5V LDO).
- 2) Connect the 24V DC power supply on the VCC and GND connectors of the EV kit board.
- 3) Set the function generator to generate a 0–3V 1kHz square wave. Connect the function generator between the TX and GND test points on the EV kit.
- 4) Connect the oscilloscope to the C/Q test point.
- 5) Turn on the power supply.
- 6) Turn on the function generator.
- 7) Verify that the C/Q output switches as expected.

IO-Link is a registered trademark of ifm electronic GmbH.

mbed is a registered trademark of ARM Limited.

Detailed Description of Hardware

The MAX14827 EV kit provides a proven layout for the MAX14827 IO-Link device transceiver.

All the power-supply and regulator input and output pins are connected to convenient connectors for easy probing. The device logic input and output pins are also provided with convenient connectors for logic testing.

The transceiver's C/Q, and DO pins are protected by TVS diodes.

See [Table 1](#) for a description of all the EV kit jumper configurations.

Regulators

The device includes two internal regulators to generate 5V (V5) and 3.3V (V33). Use the switch (SW1) to set the configuration for the V5 regulator.

Set switch SW1 to position 1 (far left) to generate 5V using the internal regulator. In this configuration, the V5 regulator is capable of driving external loads up to 30mA total external load current.

Set SW1 to position 2 (middle) to configure V5 as an input. When the internal 5V regulator is not used, V5 becomes the supply input for the internal analog and digital functions and must be supplied externally so that the device operates normally. Connect an external 5V supply to the V5 test point when SW1 is in position 2. 5V must be present on V5 for normal operation.

To drive larger loads, an external pass transistor can be used to generate the required 5V. For this mode of operation, set SW1 to position 3 (far right). This switch setting connects REG to the base of the transistor to regulate the voltage and connects V5 to the emitter.

Use jumper J4 to set the logic supply voltage. Connect J4 to 1-2 to set VL = V5 (5V). Connect J4 to 2-3 to set VL = V33 (3.3V).

Mode Selection (Pin-Mode or SPI Mode)

The MAX14827 operates with either pin-mode control or via an SPI interface.

The mode-selection switch (SW2) sets the mode of operation. Set SW2 to the on position to operate the MAX14827 in SPI mode. Set SW2 to off (left) to operate the board in pin-mode.

SW2 can be toggled after power-up.

Pin-Mode

To operate the device in pin-mode, set the mode-selection switch, SW2, to the off position (left). In pin-mode, J5, J6, and J7 are used to configure the C/Q and DO drivers.

SPI Mode

The EV kit was designed to operate with an mbed board for fast and easy prototyping. To operate the EV kit in SPI mode, connect the board to the Arduino-headers on the mbed board and set the mode-selection switch, SW2, to the on position. Remove the shunts from all of the jumpers except J4.

Evaluating the MAX14827 in Pin-Mode

Configuring the Drivers (C/Q, DO)

C/Q and DO are both configured by setting the J5, J6, and J7 jumpers in pin-mode. See [Table 2](#).

Set J5 to 1-2 (SDI/TX/NPN is high) to set the C/Q and DO drivers in NPN mode. Set J6 to 1-2 ($\overline{\text{CS}}/\text{PP}$ is high) to set C/Q and DO to push-pull mode. C/Q and DO operate in PNP mode when J5 and J6 are both set to 2-3 (SDI/TX/NPN and $\overline{\text{CS}}/\text{PP}$ are low).

The C/Q driver is enabled/disabled by setting the TXEN input. Set J8 to 1-2 (TXEN is high) to enable the C/Q driver. Apply a signal at the TX input (TP19) to set the C/Q output. C/Q is an input when J8 is 2-3 (TXEN is low).

DO cannot be disabled in Pin mode. Apply a signal at the LO input (TP15) to set the DO output.

Setting the Driver Current (C/Q, DO)

Driver current limit for the C/Q and DO outputs is selectable in pin-mode using the CLK/TXEN/200MA input. Set J7 to 2-3 to set the driver current limit to 100mA (typ). Set J7 to 1-2 to set the driver current limit to 200mA (typ).

LED Driver (LED1IN)

Close J1 to pull the LED1IN input high and turn on LED1. LED1IN is low and LED1 is off when J1 is open.

Evaluating the MAX14827 in SPI Mode

The EV kit was designed to operate with an mbed board for fast and easy prototyping. To operate the EV kit in SPI mode connect the MAX14827 EV kit to the Arduino-headers on the mbed board and configure the board for SPI operation. See *the Evaluating the MAX14827 with mbed Quick Start Guide* for more details.

Table 1. Jumper Descriptions

JUMPER	SHUNT POSITON	DESCRIPTION
J1	Closed	LED1IN is high. LED1 is on.
	Open*	LED1IN is low. LED1 is off.
J2	Closed	UARTSEL is high
	Open*	UARTSEL is low
J3	Closed	LED2 is bypassed. $\overline{\text{IRQ}}$ is pulled to VL
	Open*	$\overline{\text{IRQ}}$ is pulled to VL through LED2. LED2 turns on when $\overline{\text{IRQ}}$ is low.
J4	1-2	VL is connected to V5
	2-3*	VL is connected to V33
J5	1-2	SDI/TX/NPN is high
	2-3*	SDI/TX/NPN is low
J6	1-2	$\overline{\text{CS}}/\text{PP}$ is high
	2-3*	$\overline{\text{CS}}/\text{PP}$ is low
J7	1-2	CLK/TXEN/200MA is high
	2-3*	CLK/TXEN/200MA is low
J8	1-2	TXEN is high. C/Q driver is enabled
	2-3*	TXEN is low. C/Q driver is disabled

*Default position.

Table 2. Configuring and Setting C/Q and DO

SPI/ $\overline{\text{PIN}}$	TXEN	TX or LO	CQ_Dis or DO_Dis	CQ_Q or DO_Q	NPN MODE		PNP MODE		PP MODE	
					C/Q	DO	C/Q	DO	C/Q	DO
L	L	L	—	—	Z	Z	Z	H	Z	H
		H	—	—	Z	L	Z	Z	Z	L
	H	L	—	—	Z	Z	H	H	H	H
		H	—	—	L	L	Z	Z	L	L
H	L	L	0	0	Z	Z	Z	H	Z	H
		L	0	1	Z	Z	H	H	H	H
		H	0	0	Z	L	Z	Z	Z	L
		H	0	1	Z	Z	H	H	H	H
	H	L	0	0	Z	Z	H	H	H	H
		L	0	1	Z	Z	H	H	H	H
		H	0	0	L	L	Z	Z	L	L
		H	0	1	Z	Z	H	H	H	H
	X	X	1	X	Z	Z	Z	Z	Z	Z

Component Information, PCB Layout, and Schematic

See the following links for component information, PCB layout diagrams, and schematic.

- [MAX14827 EV BOM](#)
- [MAX14827 EV PCB Layout](#)
- [MAX14827 EV Schematic](#)

Ordering Information

PART	TYPE
MAX14827EVKIT#	EV Kit

#Denotes RoHS compliant.

Revision History

REVISION NUMBER	REVISION DATE	DESCRIPTION	PAGES CHANGED
0	12/15	Initial release	—
1	7/16	Added MAX14827A	1-5

For pricing, delivery, and ordering information, please contact Maxim Direct at 1-888-629-4642, or visit Maxim Integrated's website at www.maximintegrated.com.

Maxim Integrated cannot assume responsibility for use of any circuitry other than circuitry entirely embodied in a Maxim Integrated product. No circuit patent licenses are implied. Maxim Integrated reserves the right to change the circuitry and specifications without notice at any time.

TITLE: Bill of Materials

DATE: 07/17/2015

DESIGN: max14827_evkit_a

ITEM	REF_DES	QTY	MFG PART #	MANUFACTURER	VALUE	DESCRIPTION
1	C1, C2	2	C0603C105K4RAC; GRM188R71C105KA12; C1608X7R1C105K; EMK107B7105KA	KEMET/MURATA/TDK /TAIYO YUDEN	1UF	CAPACITOR; SMT (0603); CERAMIC C TOL=10%; MODEL=; TG=-55 DEGC TO TC=X7R
2	C3, C4	2	GRM188R72A104KA35	MURATA	0.1UF	CAPACITOR; SMT (0603); CERAMIC C TOL=10%; TG=-55 DEGC TO +125 DEGC
3	D1, D8	2	SPT02-236DDB	ST MICROELECTRONICS	SPT02- 236DDB	DIODE; TVS; UQFN-2L; PIV=38V; IF=0.3A
4	D2	1	SPT01-335DEE	ST MICROELECTRONICS	SPT01- 335DEE	DIODE; TVS; QFN6; PIV=38V; IF=0.3A
5	D3, D4, D6, D7, D9	5	SMBJ33A	ST MICROELECTRONICS	33V	DIODE; TVS; SMB (DO-214AA); VRM=
6	D5	1	ZHCS506TA	DIODES INCORPORATED	ZHCS506T A	DIODE; SCH; SMT (SOT-23); PIV=60V;
7	J1-J3	3	PCC02SAAN	SULLINS	PCC02SAA N	CONNECTOR; MALE; THROUGH HOLE STRAIGHT THROUGH; 2PINS; -65 DEG C
8	J4-J8	5	PCC03SAAN	SULLINS	PCC03SAA N	CONNECTOR; MALE; THROUGH HOLE STRAIGHT THROUGH; 3PINS; -65 DEG C
9	LED1	1	LTST-C193KGKT-5A	LITE-ON ELECTRONICS; INC.	LTST- C193KGKT- 5A	DIODE; LED; STANDARD; YELLOW-GR PIV=1.9V; IF=0.005A; -55 DEGC TO +85

10	LED2	1	LTST-C193KRKT-2A	LITE-ON ELECTRONICS; INC.	LTST- C193KRKT- 2A	DIODE; LED; STANDARD; RED; SMT (C IF=0.002A; -55 DEGC TO +85 DEGC
11	P1	1	SSQ-110-23-G-S	SAMTEC	SSQ-110- 23-G-S	CONNECTOR; FEMALE; THROUGH HO STRAIGHT; 10PINS
12	P2, P3	2	SSQ-108-23-G-S	SAMTEC	SSQ-108- 23-G-S	CONNECTOR; FEMALE; THROUGH HO STRAIGHT; 8PINS
13	P4	1	SSQ-106-03-T-S	SAMTEC	SSQ-106- 03-T-S	CONNECTOR; FEMALE; THROUGH HO STRAIGHT; 6PINS
14	Q1	1	BCP56TA	DIODES INCORPORATED	BCP56TA	TRAN; NPN SILICON PLANAR MEDIUM TRANSISTOR; NPN; SOT-223 ; PD-(2.0 (80V)
15	R1, R2, R4, R7, R8	5	CR0603-FX-1001ELF	BOURNS	1K	RESISTOR; 0603; 1K OHM; 1%; 100PP FILM
16	R3, R5, R12, R15- R17	6	CRCW060310K0FK; 9C06031A1002FK; ERJ- 3EKF1002	VISHAY DALE/YAGEO PHICOMP/PANASONIC	10K	RESISTOR; 0603; 10K; 1%; 100PPM; C FILM
17	R6	1	CRCW0603500RFK	VISHAY DALE	500	RESISTOR, 0603, 500 OHM, 1%, 100P THICK FILM
18	R9-R11	3	CRCW0603100RFK; ERJ- 3EKF1000	VISHAY DALE/PANASONIC	100	RESISTOR; 0603; 100 OHM; 1%; 100P THICK FILM
19	R13, R14	0	N/A	?	DNI	DO NOT INSTALL, RESISTOR; 0603; 0 JUMPER; 0.10W; THICK FILM; FORMFA
20	R18	1	N/A	?	10K	RESISTOR; 0402; 10K; 1%; 100PPM; 1 FILM; FORMFACTOR
21	SU1-SU7	7	STC02SYAN	SULLINS ELECTRONICS CORP.	STC02SYA N	TEST POINT; JUMPER; STR; TOTAL LE BLACK; INSULATION=PBT CONTACT= BRONZE; COPPER PLATED TIN OVERA

22	SW1	1	MHS231	COPAL ELECTRONICS INC	MHS231	SWITCH; DP3T; THROUGH HOLE; STR MHS SERIES; HYPER-MINIATURE SLID RCOIL=0 OHM; RINSULATION=100M
23	SW2	1	A6T-1104	OMRON	A6T-1104	SWITCH; SPST; THROUGH HOLE; STR 0.025A; A6T DIP SWITCH; SLIDE TYPE ASSORTMENT OF POLE CONFIGURAT OHM; RINSULATION=100M OHM; OM
24	TP1, TP3- TP5	4	5010	KEYSTONE	N/A	TEST POINT; PIN DIA=0.125IN; TOTAL LENGTH=0.445IN; BOARD HOLE=0.06 PHOSPHOR BRONZE WIRE SILVER PLA RECOMMENDED FOR BOARD THICKN NOT FOR COLD TEST
25	TP2, TP12, TP18, TP24, TP26	5	5011	KEYSTONE	N/A	TEST POINT; PIN DIA=0.125IN; TOTAL LENGTH=0.445IN; BOARD HOLE=0.06 PHOSPHOR BRONZE WIRE SILVER PLA RECOMMENDED FOR BOARD THICKN NOT FOR COLD TEST
26	TP6-TP11, TP13- TP17, TP19- TP23	16	5014	KEYSTONE	N/A	TEST POINT; PIN DIA=0.125IN; TOTAL LENGTH=0.445IN; BOARD HOLE=0.06 PHOSPHOR BRONZE WIRE SILVER PLA
25	U1	1	MAX14827ATG+	MAXIM	MAX1482 7ATG+	IC; TXRX; IO-LINK DEVICE TRANSCEIV 4X4
TOTAL		81				

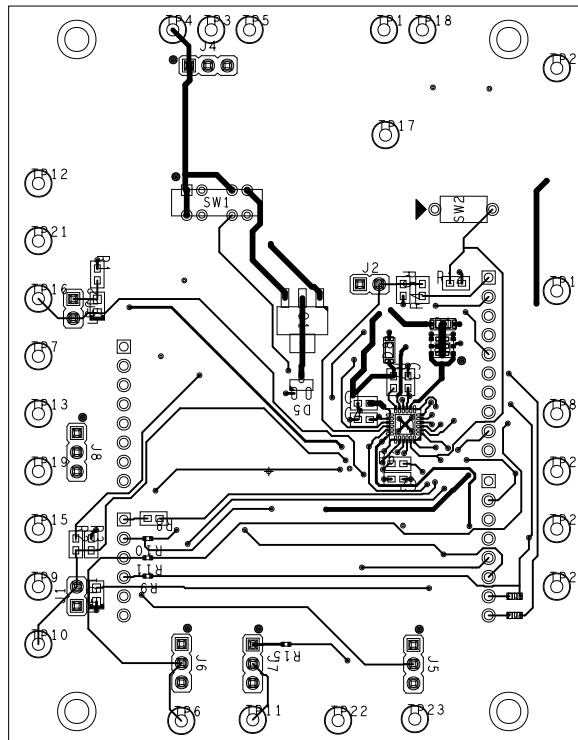

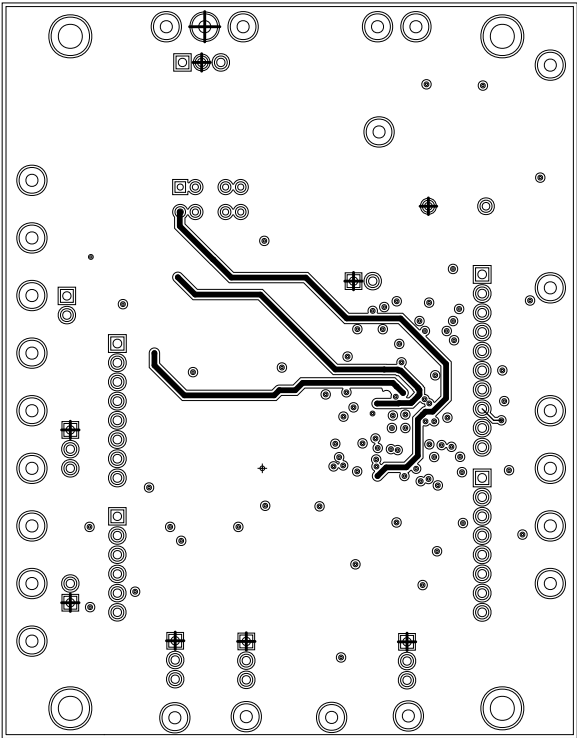

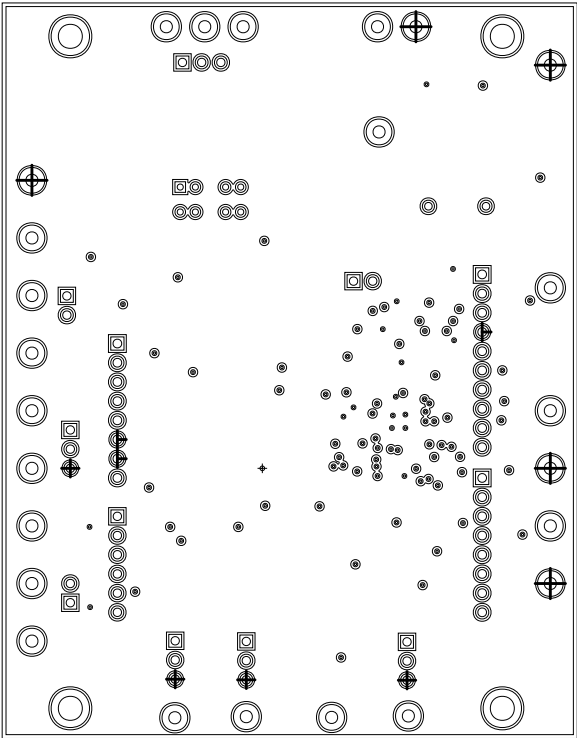

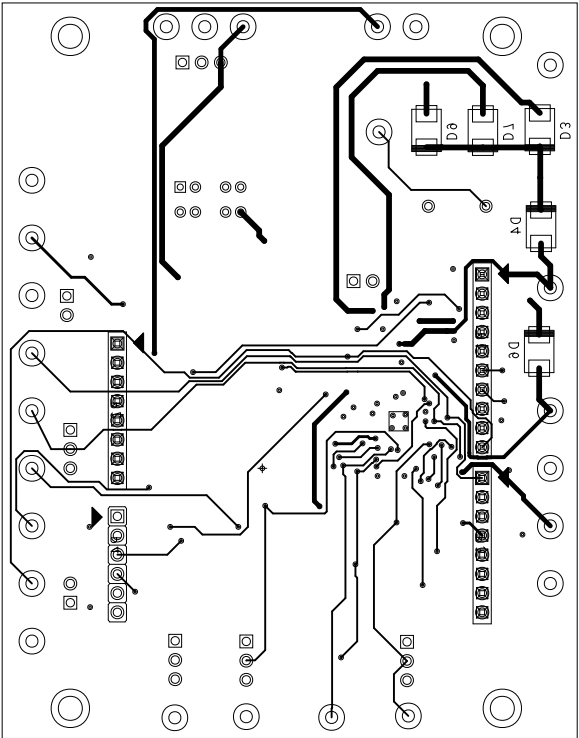

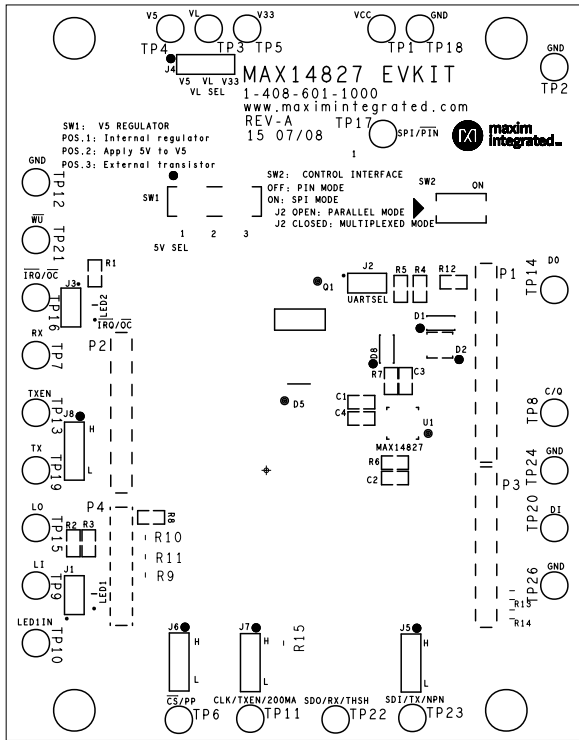

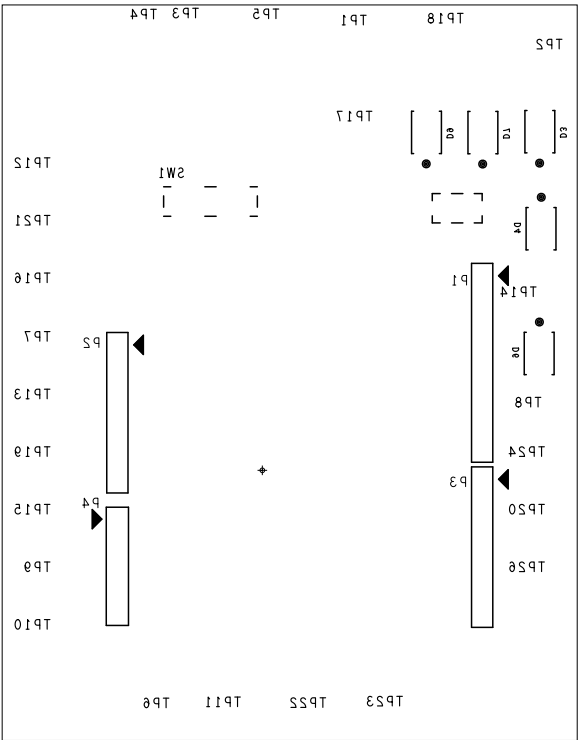

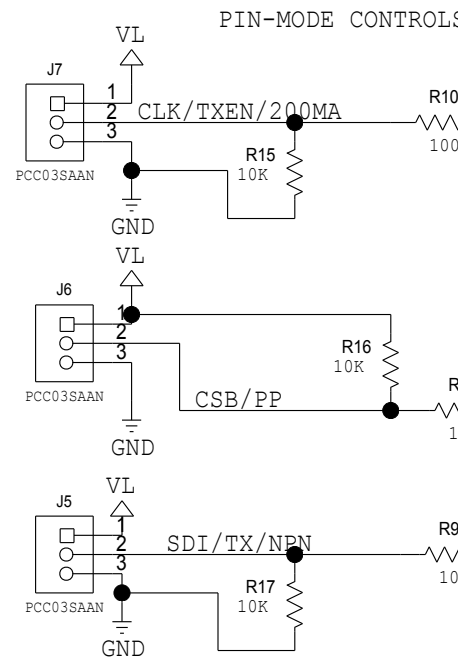
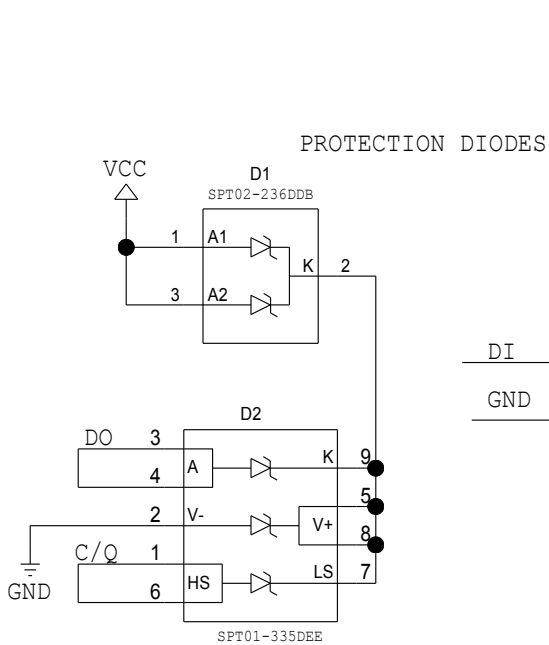
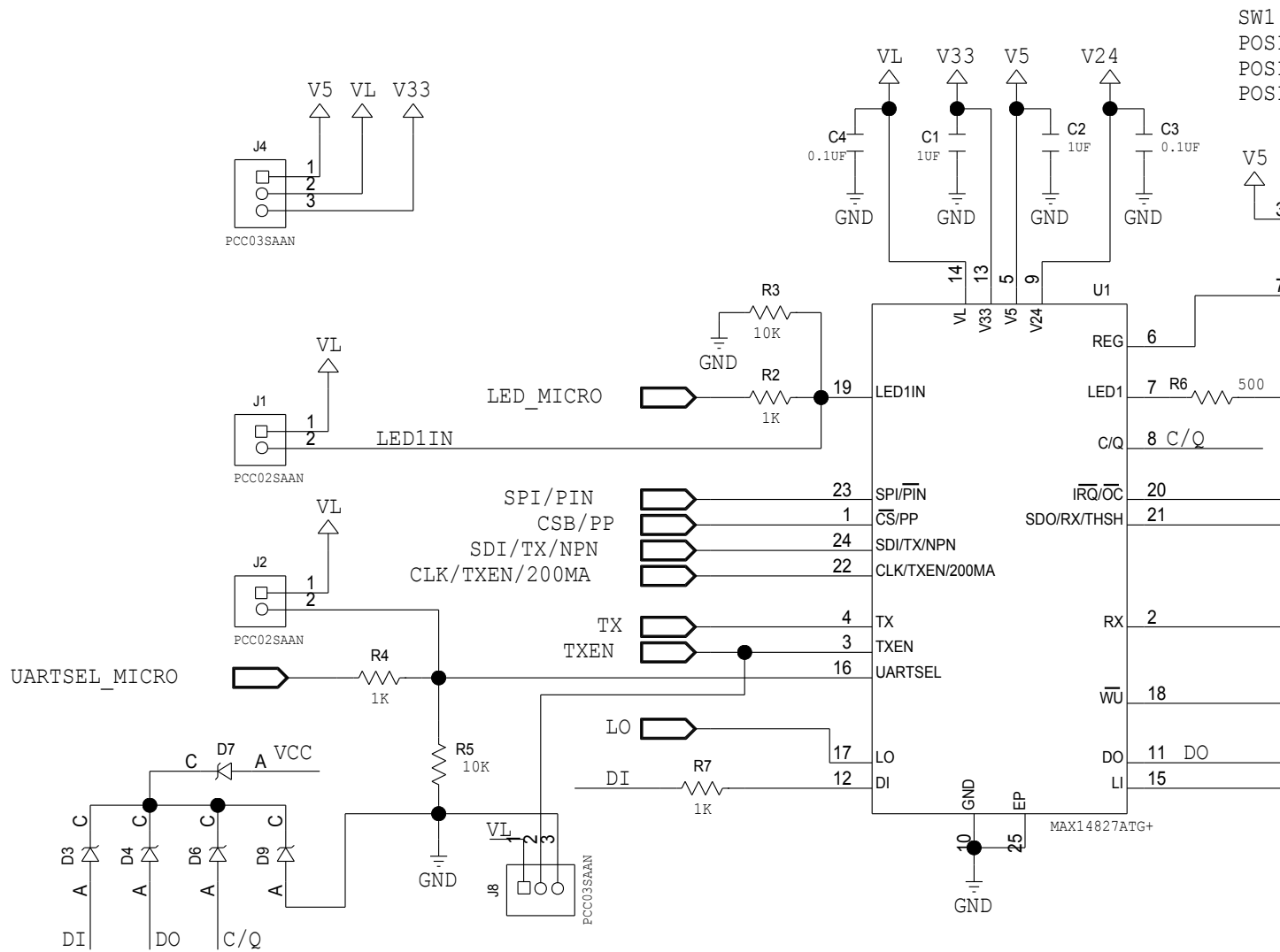

SW1
POS:
POS:
POS:

V5
↑
3

X-ON Electronics

Largest Supplier of Electrical and Electronic Components

Click to view similar products for [Interface Development Tools](#) category:

Click to view products by [Maxim](#) manufacturer:

Other Similar products are found below :

[ADP5585CP-EVALZ](#) [CHA2066-99F](#) [AS8650-DB](#) [MLX80104 TESTINTERFACE](#) [416100120-3](#) [XR18910ILEVB](#) [XR21B1421IL28-0A-EVB](#) [TW-DONGLE-USB](#) [EVAL-ADM2491EEBZ](#) [MAXREFDES23DB#](#) [MAX13235EEVKIT](#) [DFR0257](#) [XR22404CG28EVB](#) [ZLR964122L](#) [ZLR88822L](#) [EVK-U23-01S](#) [EVK-W262U-00](#) [DC327A](#) [PIM511](#) [PIM536](#) [PIM517](#) [DEV-17512](#) [STR-FUSB3307MPX-PPS-GEVK](#) [MAXREFDES177#](#) [EVAL-ADM2567EEBZ](#) [ZSSC3240KIT](#) [MAX9121EVKIT](#) [PIM532](#) [ZSC31010KITV2P1](#) [UMFT4233HPEV](#) [LVDS-18B-EVK](#) [XR20M1172G28-0B-EB](#) [SI871XSOIC8-KIT](#) [1764](#) [1833](#) [1862](#) [EVB-USB82514](#) [ATA6628-EK](#) [ATA6631-EK](#) [EVAL-CN0313-SDPZ](#) [2264](#) [MCP23X17EV](#) [PS081-EVA-HR MODULE](#) [237](#) [SMA2RJ45EVK/NOPB](#) [FR12-0002](#) [MAFR-000455-001](#) [BOB-13263](#) [ORG4572-R01-UAR](#) [CPC5622-EVAL-600R](#)