

MAX148X2 Evaluation Kit

Evaluates: MAX14853/MAX14855/
MAX14857/MAX14859

General Description

The MAX148X2 evaluation kit (EV kit) is a fully assembled and tested PCB that demonstrates the functionality of the MAX14855 isolated RS-485/RS-422 transceiver. The EV kit operates from a single 3.3V supply and features an on-board isolated power supply to power the secondary side of the circuit.

The MAX148X2EVKIT may also be used to evaluate the MAX14853, MAX14857, and MAX14859.

Features

- Operates from a Single 3.3V Supply
- Terminal Block Connectors for Easy RS-485/RS-422 Evaluation
- 2750V_{RMS} Isolation for 60s
- Fully Assembled and Tested

Quick Start

Required Equipment

- MAX148X2EVKIT
- 3.3V, 1A DC power supply
- Signal/function generator
- Oscilloscope

Startup Procedure

The EV kit is fully assembled and tested. Follow the steps below to verify board operation.

- 1) Set the DC power supply to 3.3V and connect the DC power supply between the EV kit's V_{DDA} and GNDA connectors.
- 2) Ensure that J2 and J3 are in their default positions (see [Table 1](#)).
- 3) Turn on the power supply.
- 4) Set the signal/function generator to output a 1MHz 0-to-3V square wave. *NOTE: Set the signal/function generator to operate with a high-impedance load. If the function generator does not have that option, the R1 pad is available to add a 50Ω impedance to ground.*
- 5) Connect the signal/function generator to the TXD test point.
- 6) Verify that the Y and Z outputs switch as the signal toggles.

Ordering Information appears at end of data sheet.

Detailed Description of Hardware

The MAX148X2 EV kit is a fully assembled and tested circuit board for evaluating the MAX14855 isolated RS-485/RS-422 transceiver (U1). The EV kit has been designed to allow for evaluating the MAX14855 alone or in a standard RS-485 configuration. The EV kit is powered from a single 3.3V power supply.

External Power Supply

The power on the EV kit is derived from a single 3.3V source. Connect an external supply to the VDDA test point or the P1 connector to supply the 3.3V to the logic-side (A) of the circuit. The integrated push-pull transformer driver and external transformer, TX1, generate an isolated supply for powering the isolated side (B) of the board.

Evaluating the Isolated RS-485/RS-422 Interface

Driver and Receiver Enable Selection

The MAX148X2 EV kit features three jumpers (J1, J2, and J3) to enable/disable the driver and receiver outputs. Set J1 to 2-3 to enable the receiver. Set J2 to 1-2 to enable the driver. To actively control both enables, remove J1 and J2 and close J3, which connects DE and \overline{RE} together.

Resistors R2–R4 Configuration

For end-of-the-line transceivers, close J4 and/or J7 to connect a 120Ω termination resistor (R3) between the Y and Z driver outputs and/or (R6) the A and B inputs on the MAX14855.

Pullup and pulldown resistors are generally used on the receiver inputs to guarantee a known state in the event that all nodes on the bus are in receive mode, or the cable becomes disconnected. The exact value for these resistors will vary with the application. Pads are provided for pullup (R2, R5) and pulldown (R4, R7) resistors, although the use of these resistors is purely optional. Note that the MAX14855 features true fail-safe receiver inputs, which ensures that RXD is high when the receiver inputs are shorted, open, or connected to an idle bus.

Selecting a Transformer

[Table 2](#) is a list of transformers designed to operate with the MAX14855 family. Select the transformer that best meets the performance requirements of the end application. All transformers in [Table 2](#) can be used on the MAX148X2 EV kit.

Table 1. Jumper Table (J1-J7)

JUMPER	SHUNT POSITION	DESCRIPTION
J1	1-2	Receiver is disabled. RXD is high impedance.
	2-3*	Receiver is enabled. RXD is active.
J2	1-2*	Driver is enabled.
	2-3	Driver is disabled.
J3	Open*	DE and \overline{RE} are not connected together.
	Closed	DE and \overline{RE} are connected together.
J4	Open*	Y and Z are not connected through the on-board 120Ω resistor.
	Closed	Connects the on-board 120Ω resistor between Y and Z.
J5	Open*	Z is not connected to B.
	Closed	Z is connected to B (loopback mode).
J6	Open*	Y is not connected to A.
	Closed	Y is connected to A (loopback mode).
J7	Open*	A and B are not connected through the on-board 120Ω resistor.
	Closed	Connects the on-board 120Ω resistor between A and B.

*Default position.

Table 2. Transformer Selection

MANUFACTURER/PART NUMBER	TURNS RATIO	ISOLATION VOLTAGE (V _{RMS})	A-SIDE SUPPLY (V)	CAN BE USED WITH MAXIM PART NUMBERS
HALO TGMS-1455V6LF	1CT: 1.5CT	2750	3.3V	MAX14853, MAX14855
HALO TGMS-1450V6LF	1CT:1CT	2750	5V	MAX14853, MAX14855
HALO TGMR-1455V6LF	1CT:1.5CT	5000	3.3V	MAX14857,MAX14859
HALO TGMR-1450V6LF	1CT:1CT	5000	5V	MAX14857,MAX14859
WURTH 750315227	1CT:1.7CT	2750	3.3V	MAX14853, MAX14855
WURTH 750315225	1CT:1.1CT	2750	5V	MAX14853, MAX14855
WURTH 750315231	1CT:1.7CT	5000	3.3V	MAX14857,MAX14859
WURTH 750315229	1CT:1.1CT	5000	5V	MAX14857,MAX14859

Component Information, PCB Layout, and Schematic

See the following links for component information, PCB layout diagrams, and schematic:

- [MAX148X2 EV BOM](#)
- [MAX148X2 EV PCB Layout](#)
- [MAX148X2 EV Schematic](#)

Ordering Information

PART	TYPE
MAX148X2EVKIT#	EV Kit

#Denotes RoHS compliant.

Revision History

REVISION NUMBER	REVISION DATE	DESCRIPTION	PAGES CHANGED
0	3/15	Initial release	—
1	2/16	Removed MAX14859 part number	1, 3
2	7/16	Added MAX14859 part number	1, 3

Maxim Integrated cannot assume responsibility for use of any circuitry other than circuitry entirely embodied in a Maxim Integrated product. No circuit patent licenses are implied. Maxim Integrated reserves the right to change the circuitry and specifications without notice at any time.

TITLE: Bill of Materials
 DATE: 02/04/2015
 DESIGN: max148x2_evkit_a

Revision_Type : PRODUCTION

ITEM	QTY	REF DES	Var Status	MAXINV	MFG PART #	MANUFACTURER	VALUE	DESCRIPTION
1	2	C1,C7	Pref	20-000U1-11	C0603C104K4RAC	KEMET	0.1UF	CAPACITOR; SMT (0603); CERAMIC CH TG=-55 DEGC TO +125 DEGC; TC=X7R; I DESIGN USE 20-000u1-01
2	3	C2,C6,C8	Pref	20-0001U-P6	GRM188R71E105KA12D	MURATA	1UF	CAPACITOR; SMT (0603); CERAMIC CH SERIES; TG=-55 DEGC TO +125 DEGC; T
3	2	C3,C5	Pref	20-0010U-E6	GRM21BR61E106K	MURATA	10UF	CAPACITOR; SMT (0805); CERAMIC CH 55 DEGC TO +125 DEGC; TC=X5R
4	1	C4	Pref	20-000U1-03	C0603C104K3RAC	KEMET	0.1UF	CAPACITOR; SMT; 0603; CERAMIC; 0.1u 125degC; +/-15% from -55degC to +12 NEW DESIGN USE - 20-000u1-01
5	2	D1,D2	Pref	30-MBR0520-00	MBR0520		MBR0520	DIODE; SCH; SCHOTTKY RECTIFIER; SMT DEGC TO +150 DEGC
6	2	J1,J2	Pref	01-PEC03SAAN3P-21	PEC03SAAN	SULLINS	PEC03SAAN	CONNECTOR; MALE; THROUGH HOLE; DEGC TO +125 DEGC
7	5	J3-J7	Pref	01-PEC02SAAN2P-21	PEC02SAAN	SULLINS	PEC02SAAN	CONNECTOR; MALE; THROUGH HOLE; DEGC TO +125 DEGC
8	1	P1	Pref	01-19351612P-25	1935161	PHOENIX CONTACT	1935161	CONNECTOR; FEMALE; THROUGH HOLE STRAIGHT; 2PINS
9	2	P2,P3	Pref	01-19352006P-25	1935200	PHOENIX CONTACT	1935200	CONNECTOR; FEMALE; THROUGH HOLE STRAIGHT; 6PINS
10	2	R3,R6	Pref	80-0120R-53			120	RESISTOR; 0603; 120 OHM; 5%; 200PPM
11	2	SU1,SU2	Pref	02-JMPFSTC02SYAN-00	STC02SYAN	SULLINS ELECTRONICS CORP.	STC02SYAN	TEST POINT; JUMPER; STR; TOTAL LENG INSULATION=PBT CONTACT=PHOSPHO OVERALL
12	3	T1,T8,T9	Pref	02-TPMINI5010-00	5010	Keystone	5010	TESTPOINT WITH 1.80MM HOLE DIA, R
13	4	T2,T3,T10,T11	Pref	02-TPMINI5011-00	5011	Keystone	5011	TEST POINT; PIN DIA=0.125IN; TOTAL L HOLE=0.063IN; BLACK; PHOSPHOR BR RECOMMENDED FOR BOARD THICKNES
14	8	T4-T7,T12-T15	Pref	02-TPMINI5014-00	5014	Keystone	5014	TEST POINT; PIN DIA=0.125IN; TOTAL L HOLE=0.063IN; YELLOW; PHOSPHOR BR RECOMMENDED FOR BOARD THICKNES
15	1	TX1	Pref	12-TGMS1455V6LF-09	TGMS-1455V6LF	HALO ELECTRONICS, INC	TGMS- 1455V6LF	TRANSFORMER; SMT; 1:1.5; POWER TR ONLY
16	1	U1	Pref	MAX14855	MAX14855	MAXIM	MAX14855	EVKIT PART-IC; PACKAGE CODE: W16M 0042; LAND PATTERN DRAWING NO.: 9
17	1		Pref	EPCB148X2	EPCB148X2	MAXIM	PCB	PCB: EPCB148X2
TOTAL	42							

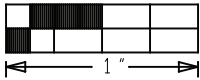
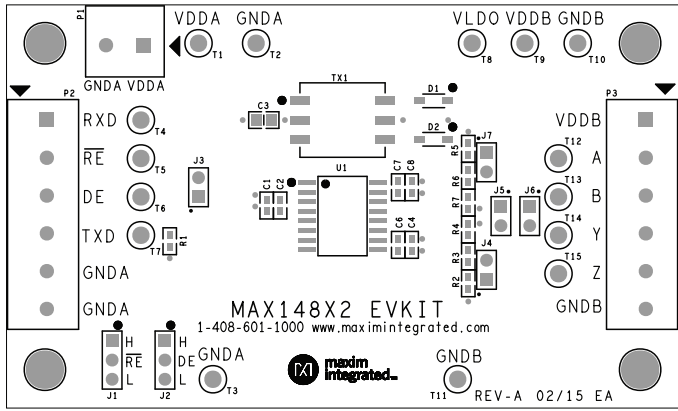

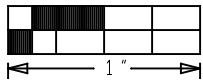
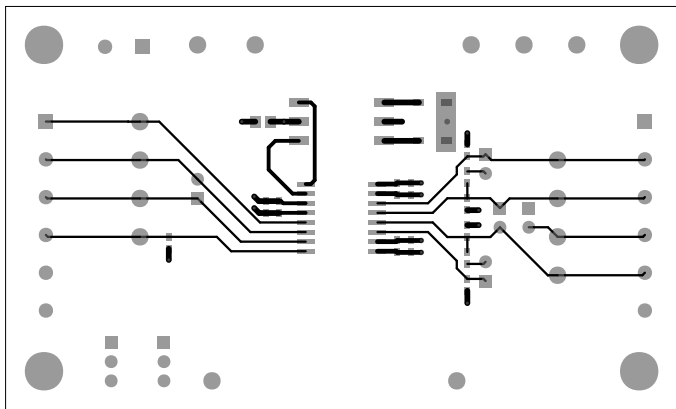

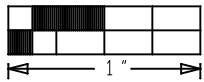
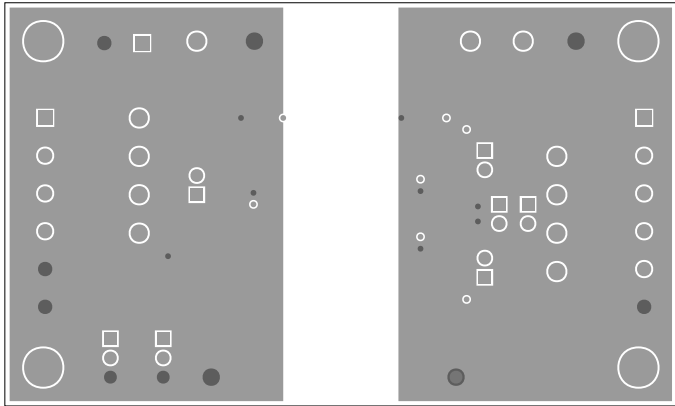

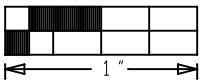
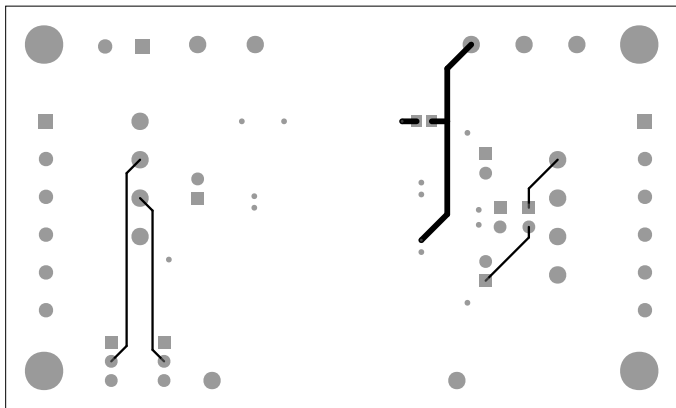

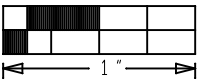
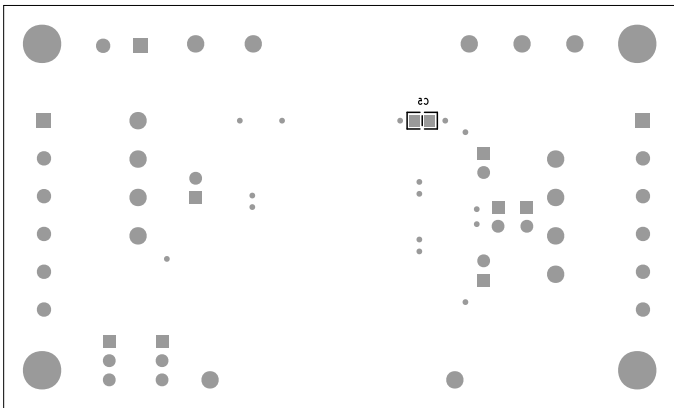

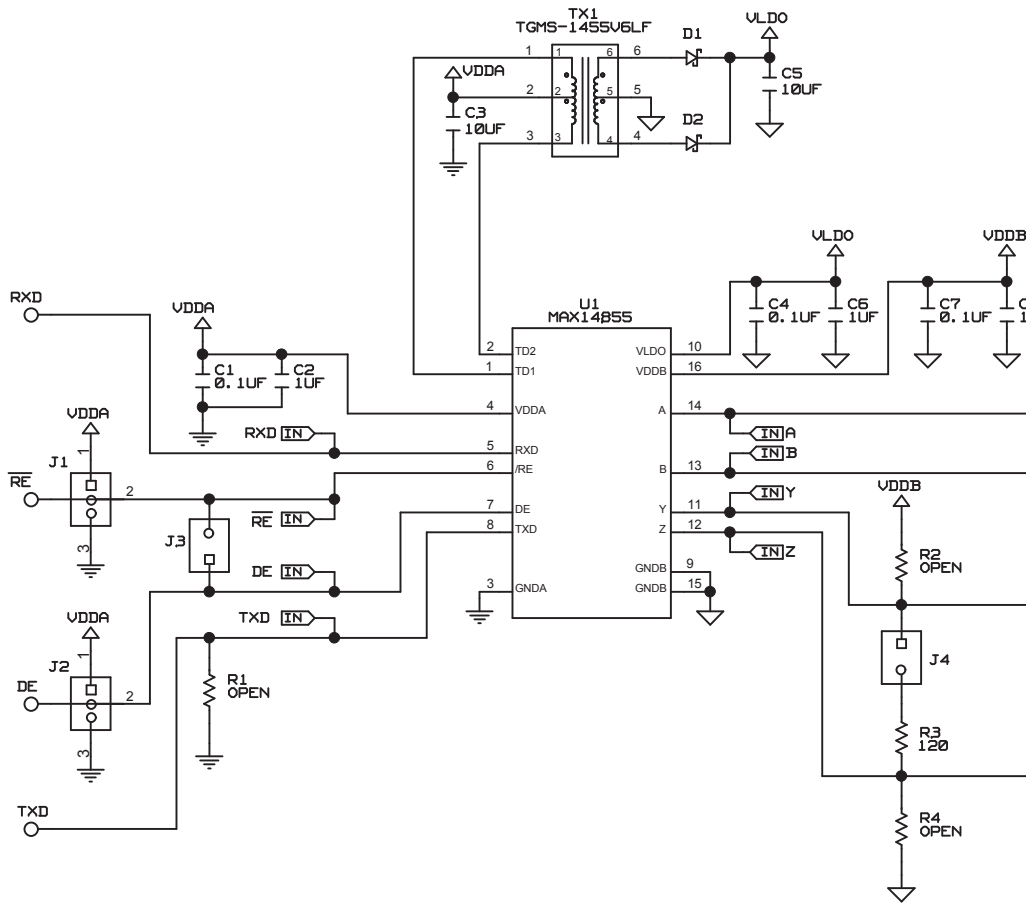
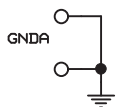
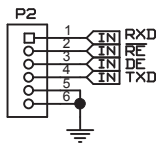
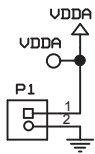

X-ON Electronics

Largest Supplier of Electrical and Electronic Components

Click to view similar products for [Interface Development Tools](#) category:

Click to view products by [Maxim](#) manufacturer:

Other Similar products are found below :

[ADP5585CP-EVALZ](#) [CHA2066-99F](#) [AS8650-DB](#) [MLX80104 TESTINTERFACE](#) [416100120-3](#) [XR18910ILEVB](#) [XR21B1421IL28-0A-EVB](#) [TW-DONGLE-USB](#) [EVAL-ADM2491EEBZ](#) [MAXREFDES23DB#](#) [MAX13235EEVKIT](#) [DFR0257](#) [XR22404CG28EVB](#) [ZLR964122L](#) [ZLR88822L](#) [EVK-U23-01S](#) [EVK-W262U-00](#) [DC327A](#) [PIM511](#) [PIM536](#) [PIM517](#) [DEV-17512](#) [STR-FUSB3307MPX-PPS-GEVK](#) [MAXREFDES177#](#) [EVAL-ADM2567EEBZ](#) [ZSSC3240KIT](#) [MAX9121EVKIT](#) [PIM532](#) [ZSC31010KITV2P1](#) [UMFT4233HPEV](#) [LVDS-18B-EVK](#) [XR20M1170G16-0A-EB](#) [XR20M1170G16-0B-EB](#) [XR20M1170G24-0B-EB](#) [XR20M1172G28-0A-EB](#) [XR20M1172G28-0B-EB](#) [SI871XSOIC8-KIT](#) [1764](#) [1833](#) [1862](#) [EVB-USB82514](#) [ATA6628-EK](#) [ATA6631-EK](#) [EVAL-CN0313-SDPZ](#) [2264](#) [MCP23X17EV](#) [PS081-EVA-HR MODULE](#) [237](#) [SMA2RJ45EVK/NOPB](#) [FR12-0002](#)