



# Two-Lane and Four-Lane DisplayPort Passive Switches with Separate AUX/HPD Control

## General Description

The MAX4998/MAX14998 high-speed passive switches route DisplayPort™ between two possible destinations or vice versa in laptops or desktop PCs. The MAX4998/MAX14998 are intended to be used where ultra-high-speed performance and minimal input capacitance is required.

The MAX4998 has three double-pole/double-throw (DPDT) switches and one single-pole/double-throw (SPDT) switch. Two DPDT switches are for high-frequency switching, one DPDT switch is for AUX, and the one SPDT switch is for HPD. The two high-frequency switches are selected by SEL1, and the AUX and HPD are selected by SEL2. This part is suitable for two-lane DisplayPort switching.

The MAX14998 has six double-pole/double-throw (DPDT) switches. Four DPDT switches are for high-frequency switching, and two DPDT switches are for AUX and HPD. The four high-frequency switches are selected by SEL1, and the AUX and HPD are selected by SEL2. This part is suitable for four-lane DisplayPort switching.

The MAX4998/MAX14998 are fully specified to operate from a single +3.3V (typ) power supply. The MAX4998 is available in a 3.5mm x 5.5mm, 28-pin TQFN package with exposed pad, and the MAX14998 is available in a 3.5mm x 9mm, 42-pin TQFN package with exposed pad. Both devices operate over the -40°C to +85°C extended temperature range.

## Applications

Notebook PCs  
Desktop PCs

## Features

- ◆ Single 3.3V Power-Supply Voltage
- ◆ 8.5GHz (typ) Bandwidth
- ◆ Support 1.6/5.4Gbps DisplayPort Signals  
Handles DisplayPort v1.1 Signals  
Handles DisplayPort v1.2 Signals
- ◆ Excellent Return Loss -13dB at 2.7GHz
- ◆ Independent High Frequency: AUX Select
- ◆ Designed for AC-Coupled Circuits
- ◆ Pass Throughs Are Maintained
- ◆ Low 850µA (max) Supply Current
- ◆ Small Packages  
3.5mm x 5.5mm, 28-Pin TQFN Package with Exposed Pad  
3.5mm x 9mm, 42-Pin TQFN Package with Exposed Pad
- ◆ Flow-Through Layout for Easy Board Layout
- ◆ ESD Protection for All I/O Pins: Human Body Model (HBM) ±4kV

## Ordering Information

PART	TEMP RANGE	PIN-PACKAGE
MAX4998ETI+T	-40°C to +85°C	28 TQFN-EP*
MAX14998ETO+T	-40°C to +85°C	42 TQFN-EP*

+Denotes a lead(Pb)-free/RoHS-compliant package.

T = Tape and reel.

\*EP = Exposed pad.

Typical Operating Circuit appears at end of data sheet.

DisplayPort is a trademark of Video Electronics Standards Association (VESA).



# Two-Lane and Four-Lane DisplayPort Passive Switches with Separate AUX/HPD Control

## ABSOLUTE MAXIMUM RATINGS

(All voltages referenced to GND, unless otherwise noted.)

V <sub>DD</sub>	-0.3V to +4V
SEL1, SEL2, COM_, NO_, NC_ (Note 1)	-0.3V to +(V <sub>DD</sub> + 0.3)V
IV <sub>COM_</sub> - V <sub>NO_I</sub> , IV <sub>COM_</sub> - V <sub>NC_I</sub> (Note 1)	0 to +2V
Continuous Current (COM_ to NO_/NC_)	±70mA
Peak Current (COM_ to NO_/NC_)	±70mA
(pulsed at 1ms, 10% duty cycle)	±70mA
Continuous Current (SEL1, SEL2)	±30mA
Peak Current (SEL1, SEL2)	±70mA
(pulsed at 1ms, 10% duty cycle)	±70mA
Continuous Power Dissipation (T <sub>A</sub> = +70°C)	
28-Pin TQFN (derate 28.6mW/°C above +70°C)	2285mW
42-Pin TQFN (derate 34.5mW/°C above +70°C)	2758mW

Operating Temperature Range	-40°C to +85°C
Junction Temperature	+150°C
Storage Temperature Range	-65°C to +150°C
Package Junction-to-Ambient Thermal Resistance (θ <sub>JA</sub> ) (Note 2)	
28-Pin TQFN	35°C/W
42-Pin TQFN	29°C/W
Package Junction-to-Case Thermal Resistance (θ <sub>JC</sub> ) (Note 2)	
28-Pin TQFN	2.7°C/W
42-Pin TQFN	2°C/W
Lead Temperature (soldering, 10s)	+300°C
Soldering Temperature (reflow)	+260°C

**Note 1:** Signals on COM\_, NO\_, NC\_, SEL1, and SEL2 exceeding V<sub>DD</sub> or GND are clamped by internal diodes. Limit forward-diode current to the maximum current rating.

**Note 2:** Package thermal resistances were obtained using the method described in JEDEC specification JESD51-7, using a four-layer board. For detailed information on package thermal considerations, refer to [www.maxim-ic.com/thermal-tutorial](http://www.maxim-ic.com/thermal-tutorial).

Stresses beyond those listed under "Absolute Maximum Ratings" may cause permanent damage to the device. These are stress ratings only, and functional operation of the device at these or any other conditions beyond those indicated in the operational sections of the specifications is not implied. Exposure to absolute maximum rating conditions for extended periods may affect device reliability.

## ELECTRICAL CHARACTERISTICS

(V<sub>DD</sub> = +3.3V ±10%, T<sub>A</sub> = T<sub>MIN</sub> to T<sub>MAX</sub>, unless otherwise noted. Typical values are at V<sub>DD</sub> = +3.3V, T<sub>A</sub> = +25°C, unless otherwise noted.) (Note 3)

PARAMETER	SYMBOL	CONDITIONS	MIN	TYP	MAX	UNITS
<b>ANALOG SWITCH</b>						
Analog Signal Range	V <sub>COM_</sub> , V <sub>NO_</sub> , V <sub>NC_</sub>				(V <sub>DD</sub> - 1.8)	V
Voltage Between COM_ and NO_/NC_	IV <sub>COM_</sub> - V <sub>NO_I</sub> , IV <sub>COM_</sub> - V <sub>NC_I</sub>		0		1.8	V
On-Resistance	R <sub>ON</sub>	I <sub>COM_</sub> = 15mA; V <sub>NO_</sub> , V <sub>NC_</sub> = 0V, +1.2V		7		Ω
On-Resistance Match Between Pairs of Same Channel	ΔR <sub>ON</sub>	V <sub>DD</sub> = +3.0V; I <sub>COM_</sub> = 15mA; V <sub>NO_</sub> , V <sub>NC_</sub> = 0V (Notes 4, 5)		0.1	2	Ω
On-Resistance Match Between Channels	ΔR <sub>ON</sub>	V <sub>DD</sub> = +3.0V; I <sub>COM_</sub> = 15mA; V <sub>NO_</sub> , V <sub>NC_</sub> = 0V (Notes 4, 5)		1.0	4	Ω
On-Resistance Flatness	R <sub>FLAT(ON)</sub>	V <sub>DD</sub> = +3.0V; I <sub>COM_</sub> = 15mA; V <sub>NO_</sub> , V <sub>NC_</sub> = 0V, +1.2V (Notes 5, 6)		0.3	1.5	Ω
NO_ or NC_ Off-Leakage Current	I <sub>NO_(OFF)</sub> I <sub>NC_(OFF)</sub>	V <sub>DD</sub> = +3.6V; V <sub>COM_</sub> = 0V, +1.2V; V <sub>NO_</sub> or V <sub>NC_</sub> = +1.2V, 0V	-1		1	μA
COM_ On-Leakage Current	I <sub>COM_(ON)</sub>	V <sub>DD</sub> = +3.6V; V <sub>COM_</sub> = 0V, +1.2V; V <sub>NO_</sub> or V <sub>NC_</sub> = V <sub>COM_</sub> or unconnected	-1		1	μA
<b>DIGITAL SIGNALS</b>						
SEL1 and SEL2 to Switch Turn-On Time	t <sub>ON_SEL</sub>	V <sub>NO_</sub> or V <sub>NC_</sub> = +1.0V, R <sub>L</sub> = 50Ω, C <sub>L</sub> = 100pF (Figure 1)		45	120	ns

# Two-Lane and Four-Lane DisplayPort Passive Switches with Separate AUX/HPD Control

## ELECTRICAL CHARACTERISTICS (continued)

(V<sub>DD</sub> = +3.3V ±10%, T<sub>A</sub> = T<sub>MIN</sub> to T<sub>MAX</sub>, unless otherwise noted. Typical values are at V<sub>DD</sub> = +3.3V, T<sub>A</sub> = +25°C, unless otherwise noted.) (Note 3)

PARAMETER	SYMBOL	CONDITIONS	MIN	TYP	MAX	UNITS
SEL1 and SEL2 to Switch Turn-Off Time	t <sub>OFF_SEL</sub>	V <sub>NO_</sub> or V <sub>NC_</sub> = +1.0V, R <sub>L</sub> = 50Ω, C <sub>L</sub> = 100pF (Figure 1)		5	50	ns
Differential Insertion Loss	SDD21	f = 0.8GHz (Figure 2)		-0.67		dB
		f = 1.35GHz (Figure 2)		-0.95		
Differential Crosstalk	SDDCTK	f = 0.8GHz (Figure 2)		-37		dB
		f = 1.35GHz (Figure 2)		-34		
Differential Return Loss	SDD11	f = 0.8GHz (Figure 2)		-20		dB
		f = 1.35GHz (Figure 2)		-14		
Signal Data Rate	BR	R <sub>S</sub> = R <sub>L</sub> = 100Ω balanced		17		Gbps
Differential -3dB Bandwidth	f-3BW	R <sub>S</sub> = R <sub>L</sub> = 100Ω balanced		8.5		GHz
Differential Off-Isolation	SDD21_OFF	f = 1.35GHz (Figure 2)		-28		dB
<b>LOGIC INPUT (SEL1, SEL2)</b>						
Input Logic-High	V <sub>IH</sub>		1.4			V
Input Logic-Low	V <sub>IL</sub>				0.5	V
Input Logic Hysteresis	V <sub>HYST</sub>			100		mV
Input Leakage Current	I <sub>IN</sub>	V <sub>SEL_</sub> = 0V or V <sub>DD</sub>	-1		+1	μA
<b>POWER SUPPLY</b>						
Power-Supply Range	V <sub>DD</sub>		3.0		3.6	V
V <sub>DD</sub> Supply Current	I <sub>DD</sub>	V <sub>SEL_</sub> = 0V or V <sub>DD</sub>		500	850	μA

**Note 3:** All units are 100% production tested at T<sub>A</sub> = +85°C. Limits over the operating temperature range are guaranteed by design and characterization and are not production tested.

**Note 4:** ΔRON = RON(MAX) - RON(MIN).

**Note 5:** Guaranteed by design. Not production tested.

**Note 6:** Flatness is defined as the difference between the maximum and minimum value of on-resistance as measured over the specified analog signal range.

## Test Circuits/Timing Diagrams

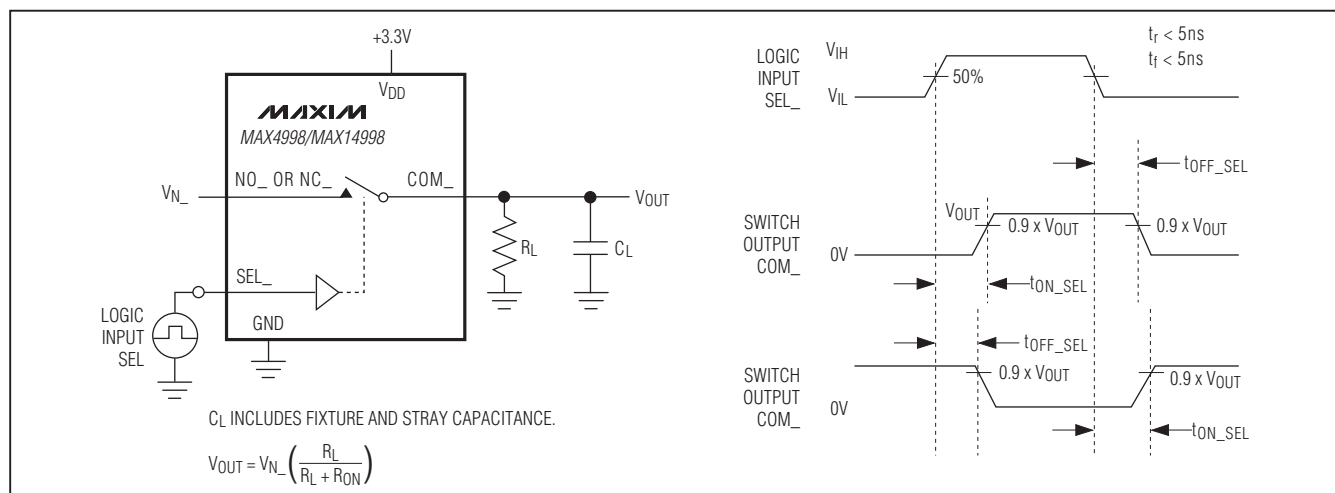
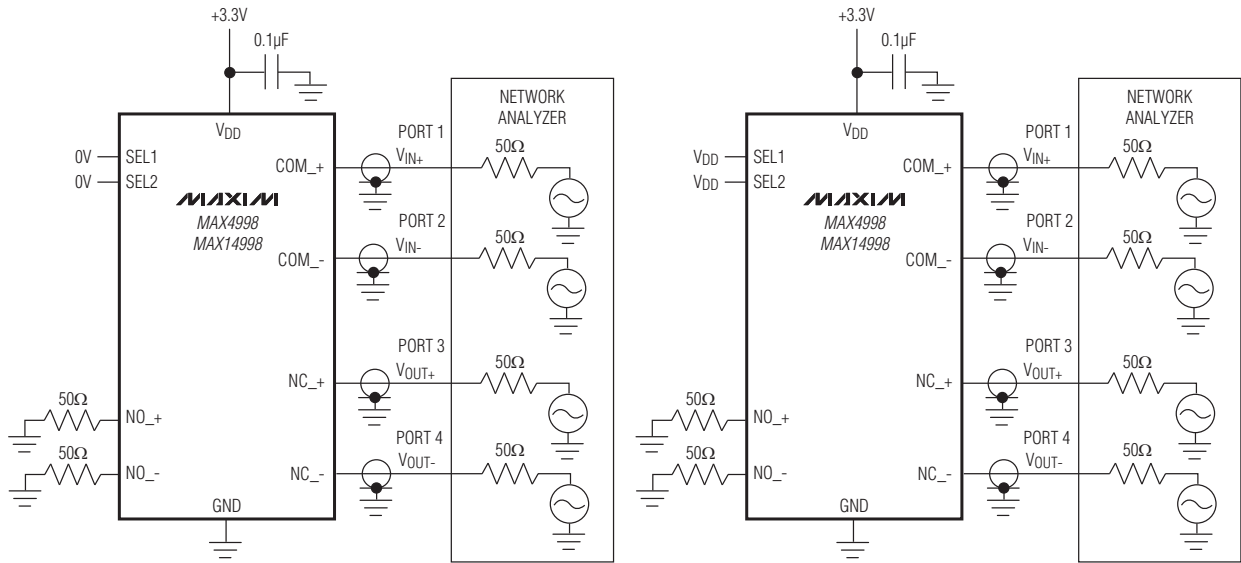

Figure 1. Switching Time

# Two-Lane and Four-Lane DisplayPort Passive Switches with Separate AUX/HPD Control

## Test Circuits/Timing Diagrams (continued)



DIFFERENTIAL INSERTION LOSS/DIFFERENTIAL RETURN LOSS

$$\text{DIFFERENTIAL INSERTION LOSS} = 20 \log \left( \frac{V_{OUT+} - V_{OUT-}}{V_{IN+} - V_{IN-}} \right)$$

DIFFERENTIAL OFF-ISOLATION

$$\text{DIFFERENTIAL OFF-ISOLATION} = 20 \log \left( \frac{V_{OUT+} - V_{OUT-}}{V_{IN+} - V_{IN-}} \right)$$

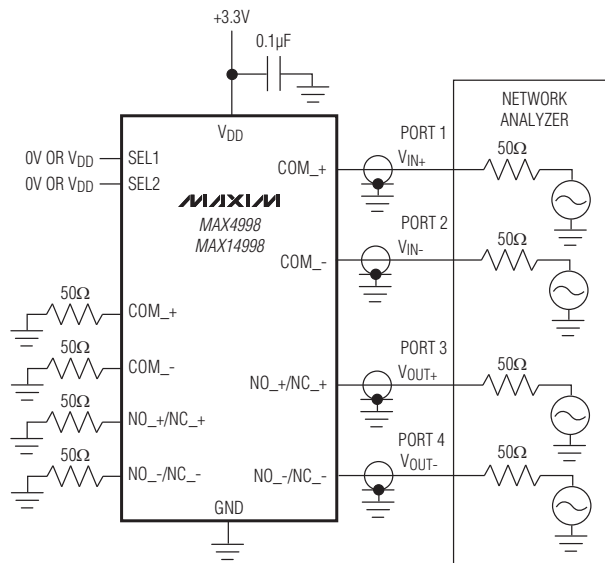

DIFFERENTIAL CROSSTALK

$$\text{DIFFERENTIAL CROSSTALK} = 20 \log \left( \frac{V_{OUT+} - V_{OUT-}}{V_{IN+} - V_{IN-}} \right)$$

MEASUREMENTS ARE STANDARDIZED AGAINST SHORTS AT IC TERMINALS.  
 DIFFERENTIAL OFF-ISOLATION IS MEASURED BETWEEN COM\_+ AND "OFF" NO\_+ OR NC\_+ TERMINAL ON EACH SWITCH.  
 DIFFERENTIAL ON-LOSS IS MEASURED BETWEEN COM\_+ AND "ON" NO\_+ OR NC\_+ TERMINAL ON EACH SWITCH.  
 DIFFERENTIAL CROSSTALK IS MEASURED BETWEEN ANY TWO PAIRS.

Figure 2. Differential On-Loss, Differential Off-Isolation, and Differential Crosstalk

# Two-Lane and Four-Lane DisplayPort Passive Switches with Separate AUX/HPD Control

## Typical Operating Characteristics

( $T_A = +25^\circ\text{C}$ , unless otherwise noted.)

MAX4998/MAX14998

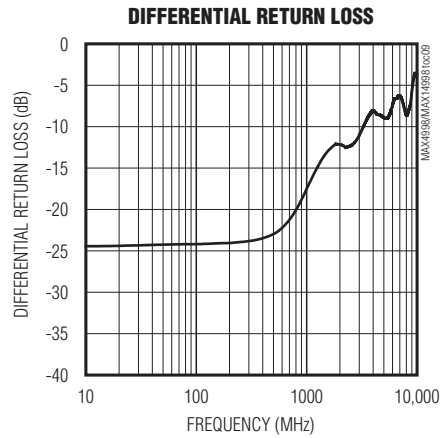
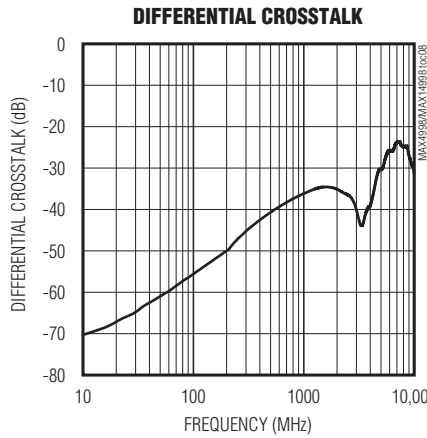
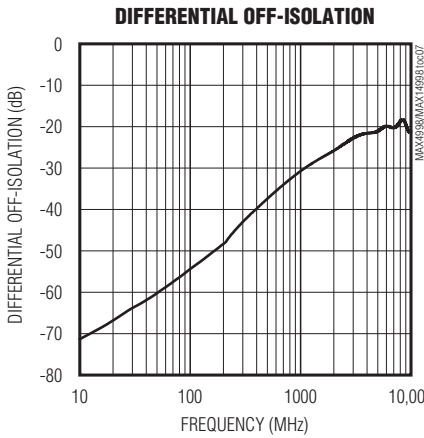
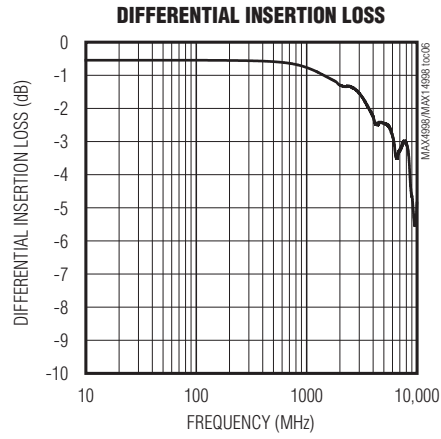
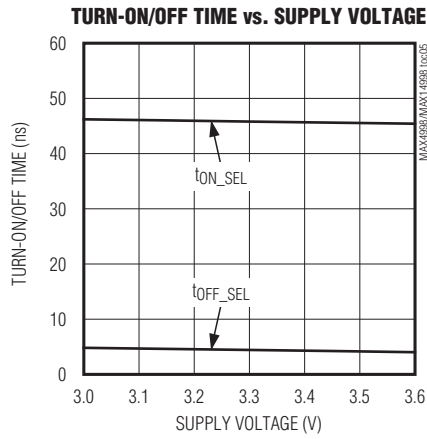
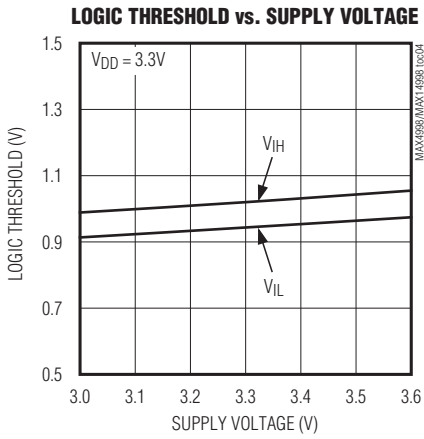
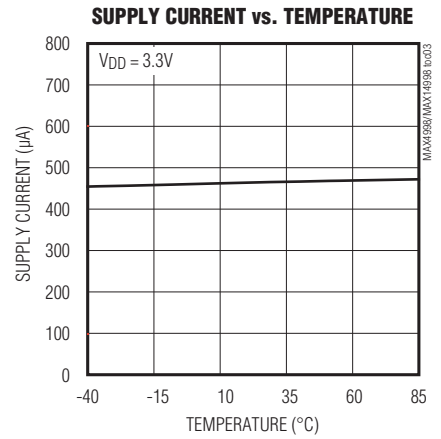
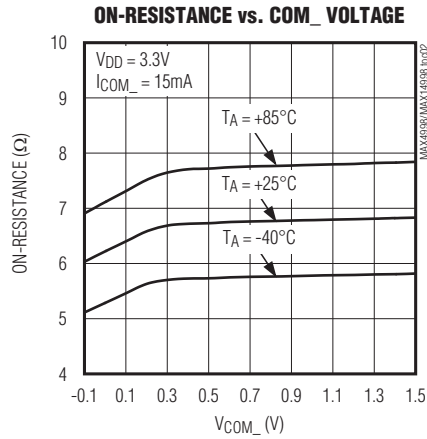
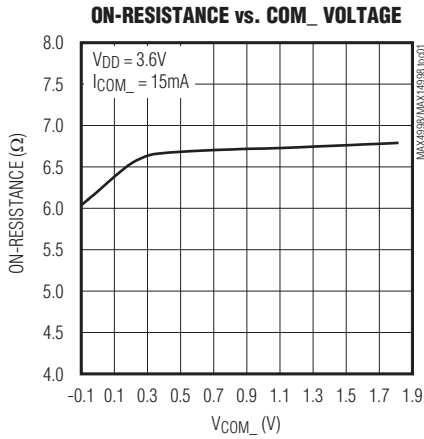

# Two-Lane and Four-Lane DisplayPort Passive Switches with Separate AUX/HPD Control

## Pin Configurations

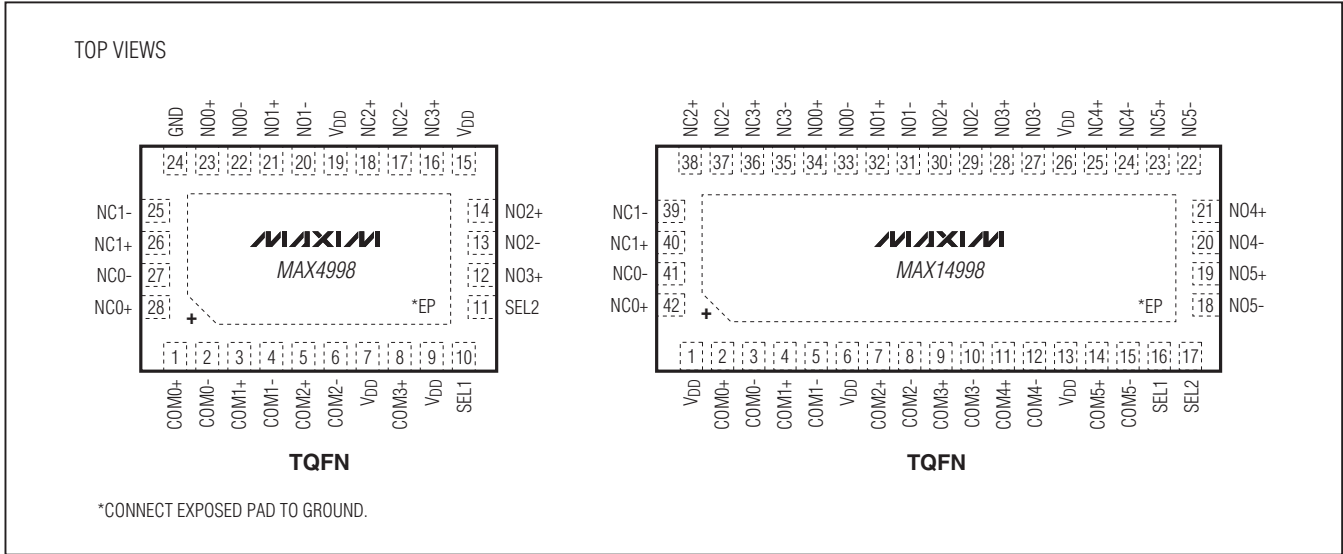

## Pin Description

PIN		NAME	FUNCTION
MAX4998	MAX14998		
1	2	COM0+	Analog Switch 1. Common positive terminal.
2	3	COM0-	Analog Switch 1. Common negative terminal.
3	4	COM1+	Analog Switch 2. Common positive terminal.
4	5	COM1-	Analog Switch 2. Common negative terminal.
5	7	COM2+	Analog Switch 3. Common positive terminal.
6	8	COM2-	Analog Switch 3. Common negative terminal.
7, 9, 15, 19	1, 6, 13, 26	VDD	Positive Supply Voltage Input. Connect VDD to a +3.0V to +3.6V supply voltage. Bypass VDD to GND with a 0.1µF ceramic capacitor placed as close to the device as possible (see the <i>Board Layout</i> section).
8	9	COM3+	Analog Switch 4. Common positive terminal.
10	16	SEL1	Control Signal Input. Selects high-frequency switching.
11	17	SEL2	Control Signal Input. Selects AUX/HPD.
12	28	NO3+	Analog Switch 4. Normally Open positive terminal.
13	29	NO2-	Analog Switch 3. Normally Open negative terminal.
14	30	NO2+	Analog Switch 3. Normally Open positive terminal.
16	36	NC3+	Analog Switch 4. Normally Closed positive terminal.
17	37	NC2-	Analog Switch 3. Normally Closed negative terminal.
18	38	NC2+	Analog Switch 3. Normally Closed positive terminal.
20	31	NO1-	Analog Switch 2. Normally Open negative terminal.
21	32	NO1+	Analog Switch 2. Normally Open positive terminal.
22	33	NO0-	Analog Switch 1. Normally Open negative terminal.

# Two-Lane and Four-Lane DisplayPort Passive Switches with Separate AUX/HPD Control

MAX4998/MAX14998

## Pin Description (continued)

PIN		NAME	FUNCTION
MAX4998	MAX14998		
23	34	NO0+	Analog Switch 1. Normally Open positive terminal.
24	—	GND	Ground
25	39	NC1-	Analog Switch 2. Normally Closed negative terminal.
26	40	NC1+	Analog Switch 2. Normally Closed positive terminal.
27	41	NC0-	Analog Switch 1. Normally Closed negative terminal.
28	42	NC0+	Analog Switch 1. Normally Closed positive terminal.
—	10	COM3-	Analog Switch 4. Common negative terminal.
—	11	COM4+	Analog Switch 5. Common positive terminal.
—	12	COM4-	Analog Switch 5. Common negative terminal.
—	14	COM5+	Analog Switch 6. Common positive terminal.
—	15	COM5-	Analog Switch 6. Common negative terminal.
—	18	NO5-	Analog Switch 6. Normally Open negative terminal.
—	19	NO5+	Analog Switch 6. Normally Open positive terminal.
—	20	NO4-	Analog Switch 5. Normally Open negative terminal.
—	21	NO4+	Analog Switch 5. Normally Open positive terminal.
—	22	NC5-	Analog Switch 6. Normally Closed negative terminal.
—	23	NC5+	Analog Switch 6. Normally Closed positive terminal.
—	24	NC4-	Analog Switch 5. Normally Closed negative terminal.
—	25	NC4+	Analog Switch 5. Normally Closed positive terminal.
—	27	NO3-	Analog Switch 4. Normally Open negative terminal.
—	35	NC3-	Analog Switch 4. Normally Closed negative terminal.
—	—	EP	Exposed Pad. Internally connected to GND. Connect to a large plane to maximize thermal performance. Not intended as an electrical part.

### Detailed Description

The MAX4998/MAX14998 high-speed passive switches route one DisplayPort source between two possible destinations or vice versa. The MAX4998 is used to switch two-lanes plus AUX/HPD DisplayPort, and the MAX14998 is used to switch four-lanes plus AUX/HPD DisplayPort.

The MAX4998/MAX14998 feature two digital control inputs (SEL1, SEL2) to switch signal paths.

#### Digital Control Inputs (SEL1, SEL2)

The MAX4998/MAX14998 provide two digital control inputs (SEL1, SEL2) to select the signal path between the COM\_ and NO\_/NC\_ channels. SEL1 selects high-frequency switching, while SEL2 selects AUX/HPD. On the MAX4998, switches 1 and 2 are high-frequency

switches and switches 3 and 4 are both low-frequency switches. On the MAX14998, switches 1, 2, 3, and 4 are high-frequency switches and switches 5 and 6 are low-frequency switches. The truth tables for the MAX4998/MAX14998 are depicted in the *Functional Diagrams/Truth Tables*. Drive SEL\_ 0V to VDD to minimize power consumption.

#### Analog Signal Levels

The MAX4998/MAX14998 accept standard DisplayPort signals to a maximum of (VDD - 1.8V). Signals on the COM\_+ channels are routed to either the NO\_+ or NC\_+ channels. Signals on the COM\_- channels are routed to either the NO\_- or NC\_- channels. The MAX4998/MAX14998 are bidirectional switches, allowing COM\_, NO\_, and NC\_, to be used as either inputs or outputs.

# Two-Lane and Four-Lane DisplayPort Passive Switches with Separate AUX/HPD Control

## Functional Diagrams/Truth Tables

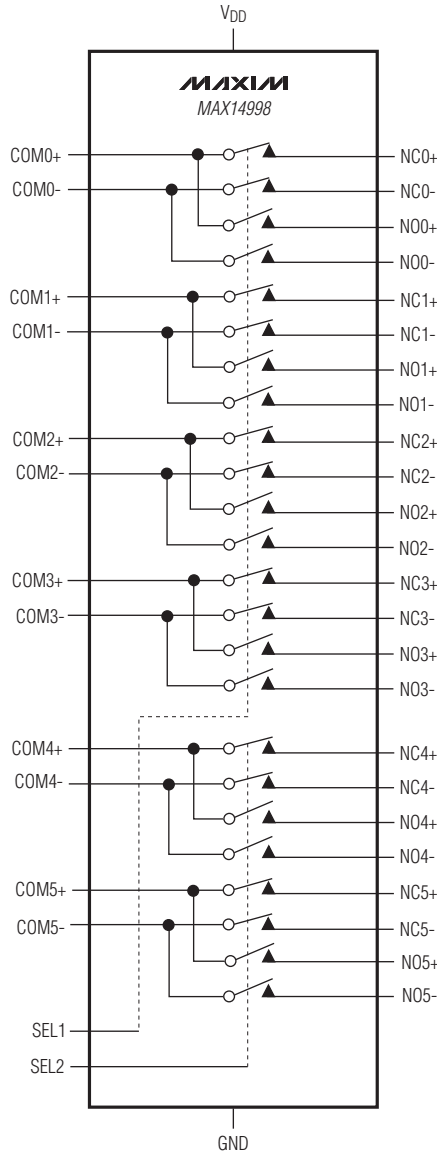

SEL1	EVENT	SWITCH
0	COM_ TO NC_	1, 2, 3, 4
1	COM_ TO NO_	1, 2, 3, 4

SEL2	EVENT	SWITCH
0	COM_ TO NC_	5, 6
1	COM_ TO NO_	5, 6

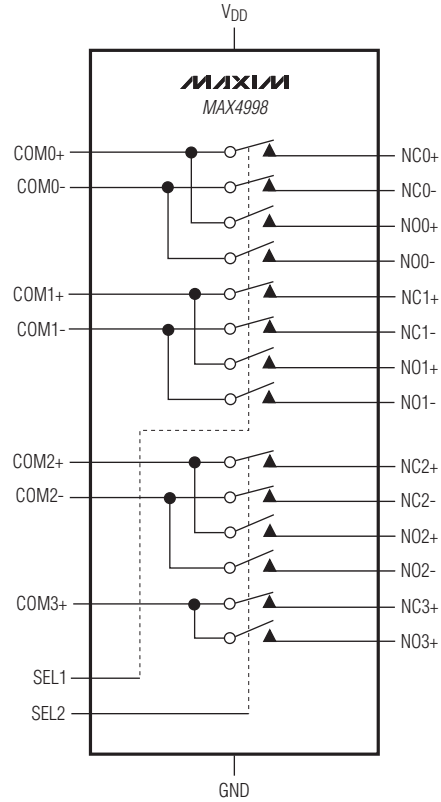

SEL1	EVENT	SWITCH
0	COM_ TO NC_	1, 2
1	COM_ TO NO_	1, 2

SEL2	EVENT	SWITCH
0	COM_ TO NC_	3, 4
1	COM_ TO NO_	3, 4



# Two-Lane and Four-Lane DisplayPort Passive Switches with Separate AUX/HPD Control

## Typical Operating Circuit

MAX4998/MAX14998

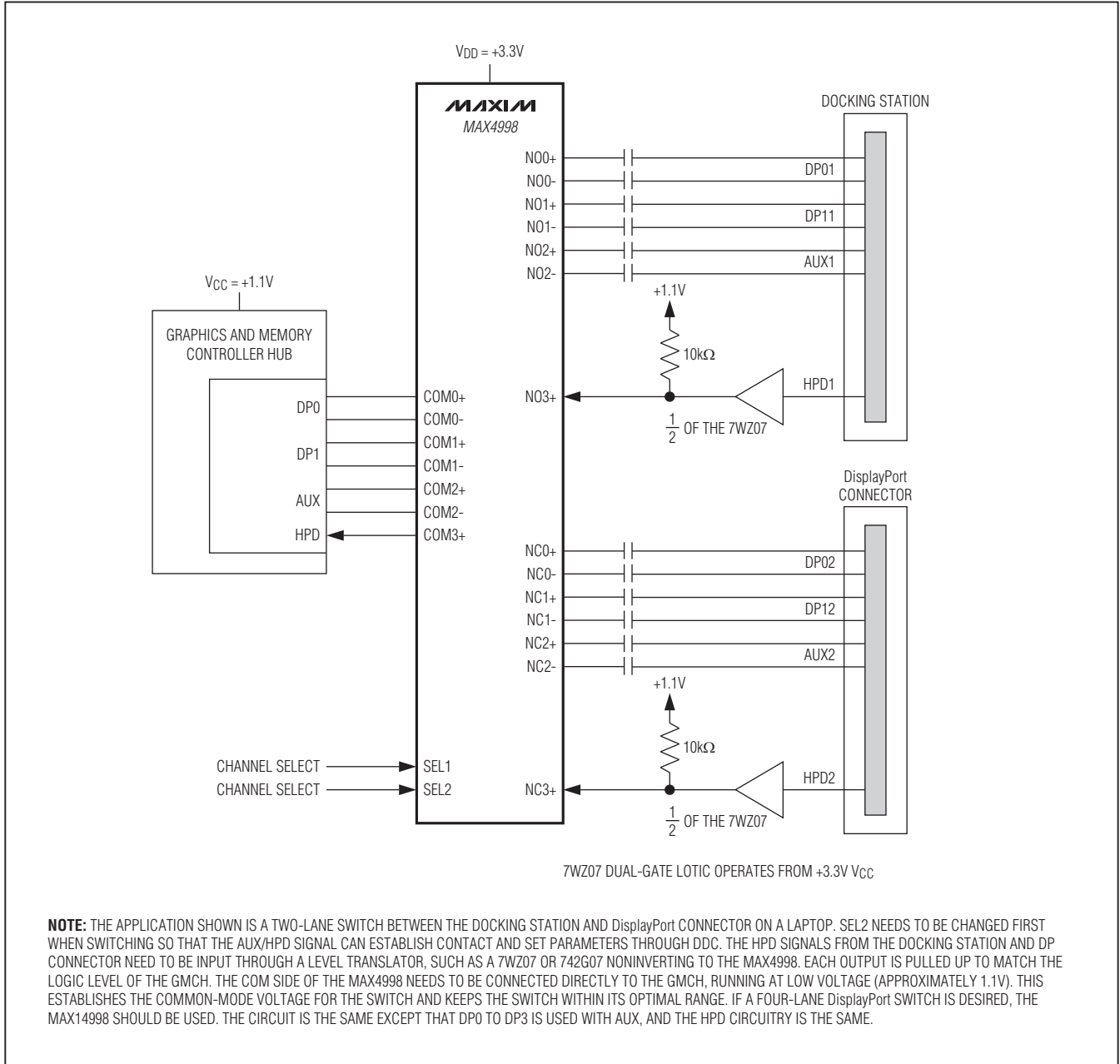

# Two-Lane and Four-Lane DisplayPort Passive Switches with Separate AUX/HPD Control

## Applications Information

### Board Layout

High-speed switches require proper layout and design procedures for optimum performance. Keep design-controlled impedance PCB traces as short as possible. Ensure that power-supply bypass capacitors are placed as close to the device as possible. Multiple bypass capacitors are recommended. Connect all grounds and the exposed pad to large ground planes.

## Chip Information

PROCESS: CMOS

## Package Information

For the latest package outline information and land patterns, go to [www.maxim-ic.com/packages](http://www.maxim-ic.com/packages). Note that a "+", "#", or "-" in the package code indicates RoHS status only. Package drawings may show a different suffix character, but the drawing pertains to the package regardless of RoHS status.

PACKAGE TYPE	PACKAGE CODE	OUTLINE NO.	LAND PATTERN NO.
28 TQFN-EP	T283555+1	<a href="#">21-0184</a>	<a href="#">90-0123</a>
42 TQFN-EP	T423590+1	<a href="#">21-0181</a>	<a href="#">90-0078</a>

# Two-Lane and Four-Lane DisplayPort Passive Switches with Separate AUX/HPD Control

## Revision History

REVISION NUMBER	REVISION DATE	DESCRIPTION	PAGES CHANGED
0	10/09	Initial release	—
1	8/10	Removed future status from the MAX14998 in the <i>Ordering Information</i> table; changed the bandwidth to 8.5GHz (typ) in the <i>Features</i> section; changed the return loss to -13dB at 2.7GHz in the <i>Features</i> section; added sub-bullets describing the DisplayPort signals v1.1 and v1.2 to the <i>Features</i> section	1

MAX4998/MAX14998

Maxim cannot assume responsibility for use of any circuitry other than circuitry entirely embodied in a Maxim product. No circuit patent licenses are implied. Maxim reserves the right to change the circuitry and specifications without notice at any time.

Maxim Integrated Products, 120 San Gabriel Drive, Sunnyvale, CA 94086 408-737-7600 \_\_\_\_\_ 11

## X-ON Electronics

Largest Supplier of Electrical and Electronic Components

*Click to view similar products for [Analogue Switch ICs](#) category:*

*Click to view products by [Maxim](#) manufacturer:*

Other Similar products are found below :

[FSA3051TMX](#) [NLAS4684FCTCG](#) [NLAS5223BLMNR2G](#) [NLVAS4599DTT1G](#) [NLX2G66DMUTCG](#) [425541DB](#) [425528R](#) [099044FB](#)  
[NLAS5123MNR2G](#) [PI5A4157CEX](#) [NLAS4717EPFCT1G](#) [PI5A3167CCEX](#) [SLAS3158MNR2G](#) [PI5A392AQE](#) [PI5A4157ZUEX](#)  
[PI5A3166TAEX](#) [FSA634UCX](#) [XS3A1T3157GMX](#) [TC4066BP\(N,F\)](#) [DG302BDJ-E3](#) [PI5A100QEX](#) [HV2605FG-G](#) [HV2301FG-G](#)  
[RS2117YUTQK10](#) [RS2118YUTQK10](#) [RS2227XUTQK10](#) [ADG452BRZ-REEL7](#) [MAX4066ESD+](#) [MAX391CPE+](#) [MAX4730EXT+T](#)  
[MAX314CPE+](#) [BU4066BCFV-E2](#) [MAX313CPE+](#) [BU4S66G2-TR](#) [NLASB3157MTR2G](#) [TS3A4751PWR](#) [NLAS4157DFT2G](#)  
[NLAST4599DFT2G](#) [NLAST4599DTT1G](#) [DG419LDY+T](#) [DG300BDJ-E3](#) [DG2503DB-T2-GE1](#) [TC4W53FU\(TE12L,F\)](#) [HV2201FG-G](#)  
[74HC2G66DC.125](#) [DG3257DN-T1-GE4](#) [ADG1611BRUZ-REEL7](#) [DG2535EDQ-T1-GE3](#) [LTC201ACN#PBF](#) [74LV4066DB,118](#)