



# MAX15046B Evaluation Kit

## General Description

The MAX15046B evaluation kit (EV kit) is a fully assembled and tested circuit board that contains all the components necessary to evaluate the performance of the MAX15046B 10A synchronous step-down controller. The MAX15046 IC is available in a small 16-pin QSOP package with an exposed pad.

The MAX15046B EV kit requires a 5V to 40V input-voltage range power supply that provides up to 7A for normal operation. The MAX15046B EV kit output is configured to 3.3V and delivers up to 10A output current. The controller's switching frequency is programmed to 350kHz. The MAX15046B EV kit includes PCB pads to enable the circuit and to monitor the power-good output.

## Features

- ◆ 5V to 40V (24V typ) Input Range
- ◆ Optional 4.5V to 5.5V Input Range
- ◆ 3.3V at 10A Output
- ◆ 350kHz Switching Frequency
- ◆ Enable Input
- ◆ Power-Good Output
- ◆ Fully Assembled and Tested

## Ordering Information

PART	TYPE
MAX15046BEVKIT+	EV Kit

+Denotes lead(Pb)-free and RoHS compliant.

## Component List

DESIGNATION	QTY	DESCRIPTION
C1	1	100 $\mu$ F $\pm$ 20%, 50V electrolytic capacitor ( 8mm x 10.2mm) Panasonic EEVFK1H101P
C2, C19	2	0.1 $\mu$ F $\pm$ 10%, 50V X7R ceramic capacitors (0603) Murata GRM188R71H104K
C3	1	1 $\mu$ F $\pm$ 10%, 50V X5R ceramic capacitor (0805) Murata GRM21BR71H105K
C4	1	4.7 $\mu$ F $\pm$ 10%, 6.3V X5R ceramic capacitor (0603) Murata GRM188R60J475K
C5	1	2.2 $\mu$ F $\pm$ 10%, 6.3V X5R ceramic capacitor (0603) Murata GRM188R60J225K
C6, C7	2	10 $\mu$ F $\pm$ 20%, 50V X5R ceramic capacitors (1210) Taiyo Yuden UMK325BJ106MM
C8	1	0.47 $\mu$ F $\pm$ 10%, 16V X7R ceramic capacitor (0603) Murata GRM188R71C474K
C9	1	1000pF $\pm$ 5%, 50V C0G ceramic capacitor (0805) Murata GRM2165C1H102J

DESIGNATION	QTY	DESCRIPTION
C10, C11	2	100 $\mu$ F $\pm$ 20%, 6.3V X5R ceramic capacitors (1210) Murata GRM32ER60J107M
C12	1	47 $\mu$ F $\pm$ 10%, 6.3V X5R ceramic capacitor (1206) Murata GRM31CR60J476K
C13	1	68pF $\pm$ 5%, 50V C0G ceramic capacitor (0603) Murata GRM1885C1H680J
C14	1	15pF $\pm$ 5%, 50V C0G ceramic capacitor (0603) Murata GRM1885C1H150J
C15	1	1500pF $\pm$ 10%, 50V C0G ceramic capacitor (0603) Murata GRM1885C1H152K
C16	1	220pF $\pm$ 5%, 50V C0G ceramic capacitor (0603) Murata GRM1885C1H221J
C17, C20	0	Not installed, ceramic capacitors (0603)
C18	0	Not installed, ceramic capacitor (0805)



# MAX15046B Evaluation Kit

Evaluates: MAX15046B

## Component List (continued)

DESIGNATION	QTY	DESCRIPTION
D1	1	0.5A, 60V Schottky diode (SOT23) Diodes, Inc. ZHCS506 (Top Mark: S56)
JU1	1	2-pin header
JU2	1	3-pin header
L1	1	1.5 $\mu$ H, 27.5A inductor Vishay IHLP-4040DZ ER1R5M
N1	1	60V, 6.2A n-channel MOSFET (Powerpack 8 SO) Vishay (Siliconix) Si7850DP-T1-E3
N2	1	60V, 11A n-channel MOSFET (Powerpack 8 SO) Vishay (Siliconix) Si7460DP-T1-E3
PGND (x2), VIN, VOUT	4	Uninsulated banana jacks
TP1, TP2	2	PC mini red test points
R1	1	0 $\Omega$ $\pm$ 5% resistor (1210)
R3	1	10 $\Omega$ $\pm$ 5% resistor (0603)
R4	1	51k $\Omega$ $\pm$ 5% resistor (0603)
R5	1	2.2 $\Omega$ $\pm$ 5% resistor (0603)

DESIGNATION	QTY	DESCRIPTION
R7	1	10 $\Omega$ $\pm$ 1% resistor (1210) Vishay (Dale) CRCW121010R00FNEA
R8	0	Not installed, resistor (0603)
R9	1	32.4k $\Omega$ $\pm$ 1% resistor (0603)
R10	1	22.6k $\Omega$ $\pm$ 1% resistor (0603)
R11	1	3.65k $\Omega$ $\pm$ 1% resistor (0603)
R12	1	105k $\Omega$ $\pm$ 1% resistor (0603)
R13	1	23.2k $\Omega$ $\pm$ 1% resistor (0603)
R14	1	43.2k $\Omega$ $\pm$ 1% resistor (0603)
R15	1	49.9 $\Omega$ $\pm$ 1% resistor (0805)
R16, R17	2	0 $\Omega$ $\pm$ 5% resistors (0603)
U1	1	10A synchronous step-down controller (16 QSOP-EP*) Maxim MAX15046BAEE+
—	2	Shunts (JU1, JU2)
—	1	PCB: MAX15046B EVALUATION KIT+

\*EP = Exposed pad.

## Component Suppliers

SUPPLIER	PHONE	WEBSITE
Diodes, Inc.	805-446-4800	www.diodes.com
Murata Electronics North America, Inc.	770-436-1300	www.murata-northamerica.com
Panasonic Corp.	800-344-2112	www.panasonic.com
Taiyo Yuden	800-348-2496	www.t-yuden.com
Vishay	402-563-6866	www.vishay.com

**Note:** Indicate that you are using the MAX15046B when contacting these component suppliers.

# MAX15046B Evaluation Kit

Evaluates: MAX15046B

## Quick Start

### Required Equipment

- Adjustable 5V to 40V, 7A DC power supply
- Electronic load capable of sinking up to 10A (e.g., HP6060B)
- Two voltmeters

### Procedure

The MAX15046B EV kit is fully assembled and tested. Follow the steps below to verify board operation.

**Caution: Do not turn on the power supply until all connections are completed.**

- 1) Verify that a shunt is not installed on jumper JU1 (VIN input source for U1).
- 2) Install a shunt on pins 1-2 of jumper JU2 (VOUT enabled).
- 3) Connect a voltmeter to the VOUT and PGND PCB pads.
- 4) Connect a voltmeter to the PGOOD and GND PCB pads.
- 5) Connect a 10A electronic load to the VOUT and PGND banana jack connectors.
- 6) Connect a DC power supply to the VIN and PGND banana jack connectors and set the voltage to 24V.
- 7) Enable the power supply.
- 8) Enable the electronic load and set it to 5A.
- 9) Verify that the voltmeters at VOUT and PGOOD are 3.3V and approximately 5.2V, respectively.

## Detailed Description of Hardware

The MAX15046B EV kit is a fully assembled and tested circuit board that contains all the components necessary to evaluate the performance of the MAX15046B 10A synchronous step-down controller. The circuit uses a MAX15046B step-down controller IC to implement a step-down synchronous DC-DC converter circuit. The MAX15046B EV kit is designed to operate from a single DC power supply that provides 5V to 40V and 7A of current. For improved efficiency, the MAX15046B controller can also be operated using a 4.5V to 5.5V power source applied at the VIN and PGND PCB pads and shorting together (JU1) the MAX15046B IC IN and VCC inputs. When operating the MAX15046B EV kit using separate power-supply sources at the VIN connector and VCC PCB pads, apply power at the VIN and PGND connectors and then the VCC and GND PCB pads.

The MAX15046B EV kit converter is configured to 3.3V and provides up to 10A output current. The switching frequency is set to 350kHz using resistor R14. The EV kit features PCB pads to evaluate the enable input signal (EN) and to monitor the power-good (PGOOD) output signal.

### Converter Input Source

Banana jack connectors VIN and PGND connect the power source for the converter. The MAX15046B EV kit converter output performance is optimized over the 5V to 40V VIN input voltage, while providing up to 10A output current. The MAX15046B EV kit can operate at higher output currents; however, performance may be degraded due to the limitation of the components used on the circuit, which might require reevaluation.

### MAX15046B IC Bias Input (JU1)

The MAX15046B EV kit features an option to select the bias input for the MAX15046B IC controller when configuring the EV kit to operate with an input source less than 6V. Jumper JU1 selects the input-voltage source for the MAX15046B IC controller VCC pin. Remove the shunt on jumper JU1 to power the MAX15046B IC using the power source applied at the VIN and PGND banana jack connectors. The input-voltage range at VIN in this configuration is 5.5V to 40V. When operating the MAX15046B EV kit using separate power-supply sources at the VIN connector and VCC PCB pads, apply power at the VIN and PGND connectors first and then the VCC and GND PCB pads.

To operate with a source less than 6V, install a shunt across jumper JU1. Then power the MAX15046B EV kit VIN input using a power source applied at the VIN and PGND PCB pads. Note that the power source applied to the VIN PCB pad in this configuration has a 4.5V to 5.5V input-voltage range.

**Table 1. MAX15046B Bias Input Configuration (JU1)**

SHUNT POSITION	MAX15046B IN PIN	MAX15046B EV KIT INPUT RANGE (V)
Installed	Connected to VCC	4.5 to 5.5
Not installed	Connected to VIN	5.5 to 40

# MAX15046B Evaluation Kit

## Configuring the Output Voltage

The MAX15046B EV kit's VOUT voltage can be reconfigured between 0.6V to 0.85 x VIN. To configure the MAX15046B EV kit's output voltage, refer to the *Setting the Output Voltage* section in the MAX15046 IC data sheet for instructions on selecting new resistor values. Capacitors C13–C16 and resistors R10 and R11 provide a compensation network for VOUT on the MAX15046B EV kit circuit.

Refer to the *Inductor Selection*, *Input Capacitor*, and *Compensation Design* sections in the MAX15046 IC data sheet to verify whether other components need replacement for proper operation after reconfiguring the output voltage.

## Current-Limit Thresholds

The MAX15046B IC employs a current-sensing algorithm using the low-side MOSFET on-resistance as a current-sensing element to limit the inductor current. The inductor current is sensed in the converter by sensing the voltage drop across the on-resistance (RDSON) of low-side MOSFET N2. The MAX15046B EV kit's valley and sink current limits are set to 13.5A and 6.75A, respectively.

Resistor R9 sets VOUT valley current-limit voltage threshold (VITH) to 162mV. The sink current-limit voltage threshold is approximately one-half the valley current-limit voltage threshold. Use the following equation to reconfigure the valley current-limit voltage threshold:

$$R_{LIM}(\Omega) = \frac{V_{ITH} \times 10}{50 \times 10^{-6}}$$

where VITH is the valley current-limit voltage threshold in volts and RLIM is R9 in ohms.

Refer to the *Current-Limit Circuit (LIM)* and *Setting the Valley Current Limit* sections in the MAX15046 IC data sheet for further instructions on computing the MAX15046B EV kit valley and sink current limits.

Surface-mount PCB pads for resistor R8 are provided to implement foldback current-limit capabilities if required.

## Switching Frequency

The MAX15046B controller switching frequency is set to 350kHz by resistor R14. Replace resistor R14 with a new resistor value to program the switching frequency between 100kHz and 1MHz. Use the following equa-

tion to calculate R14 when reconfiguring the switching frequency:

$$R14 = \frac{17.3 \times 10^9}{f_{SW} + (1 \times 10^{-7}) \times (f_{SW}^2)}$$

where fsw is in hertz and R14 is in ohms.

When reconfiguring the EV kit controller switching frequency, it may be necessary to change compensation network component to new values. Refer to the *Compensation Design* section in the MAX15046 IC data sheet for computing new compensation component values.

## Power-Good Output (PGOOD)

The MAX15046B EV kit provides a PGOOD PCB pad to monitor the status of the U1 power-good output signal. PGOOD is high when VOUT rises 94.5% (typ) above its programmed output voltage. When VOUT falls below 92% (typ) of its nominal regulated voltage, PGOOD is pulled low. The PGOOD signal is pulled up to VCC by resistor R4.

## Enable Control (JU2)

Jumper JU2 configures the MAX15046B EV kit's output enable for turn on/off control. Install a shunt on pins 1-2 of jumper JU2 to enable VOUT. Conversely, VOUT is disabled when the shunt is placed across pins 2-3 of jumper JU2. Alternatively, the MAX15046B IC enable pin (EN) can be controlled by an external controller. Surface-mount PCB pads for optional capacitor C17 are included to filter noise that may be introduced on the EN pin.

**Table 2. Enable Control (JU2)**

SHUNT POSITION	EN PIN	VOUT OUTPUT
1-2	Connected to VCC through R3	Enabled
2-3	Pulled down to GND	Disabled
Not installed	External controller	External controller enables/disables

# MAX15046B Evaluation Kit

Evaluates: MAX15046B

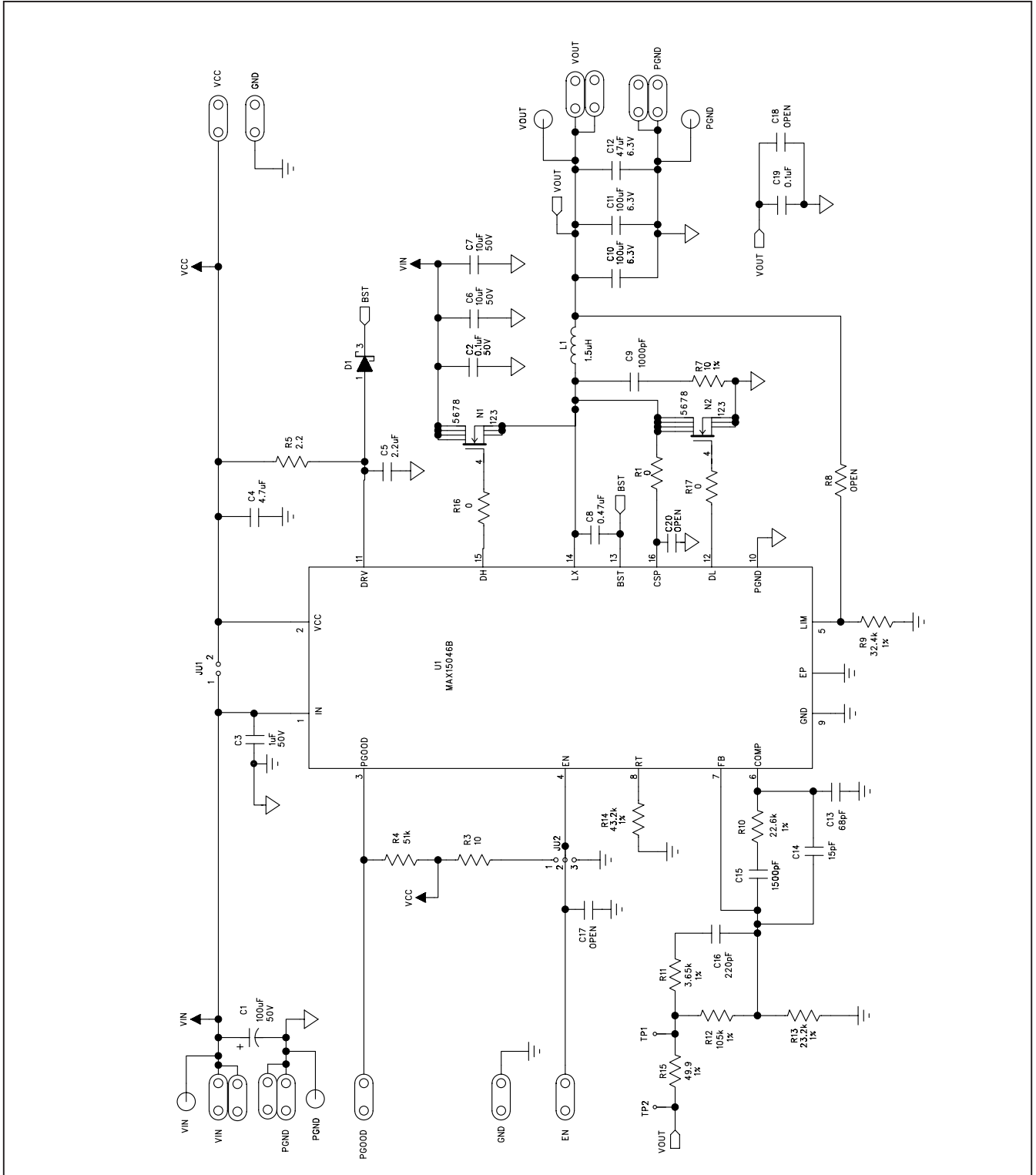

Figure 1. MAX15046B EV Kit Schematic

# MAX15046B Evaluation Kit

**Evaluates: MAX15046B**

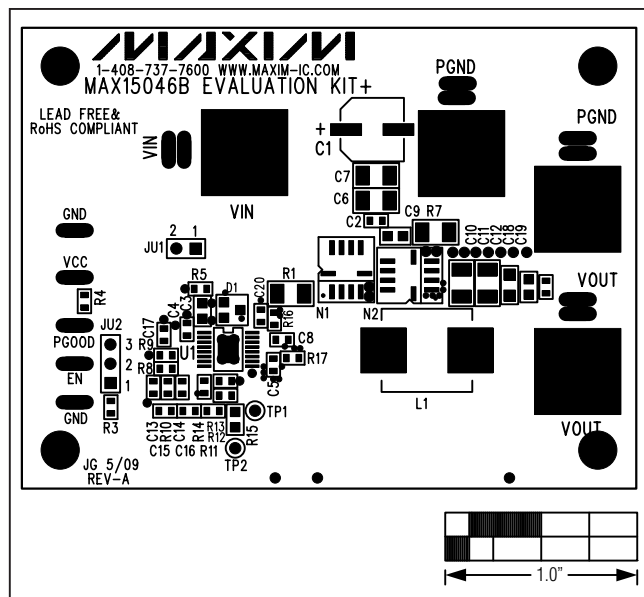

Figure 2. MAX15046B EV Kit Component Placement Guide—Component Side

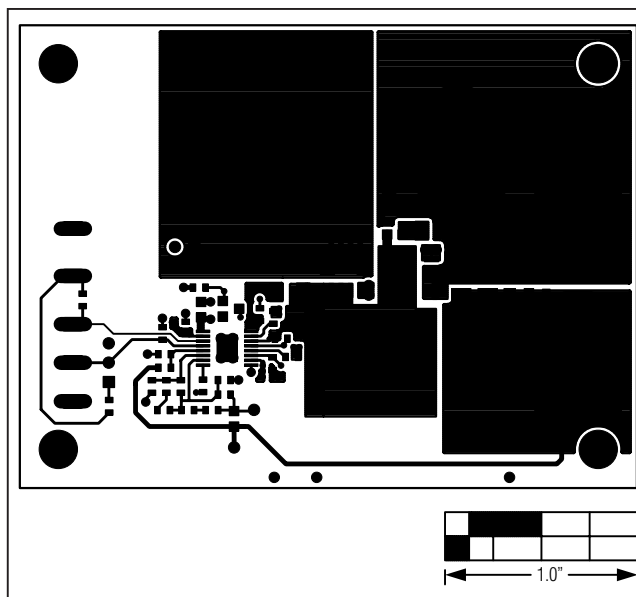

Figure 3. MAX15046B EV Kit PCB Layout—Component Side

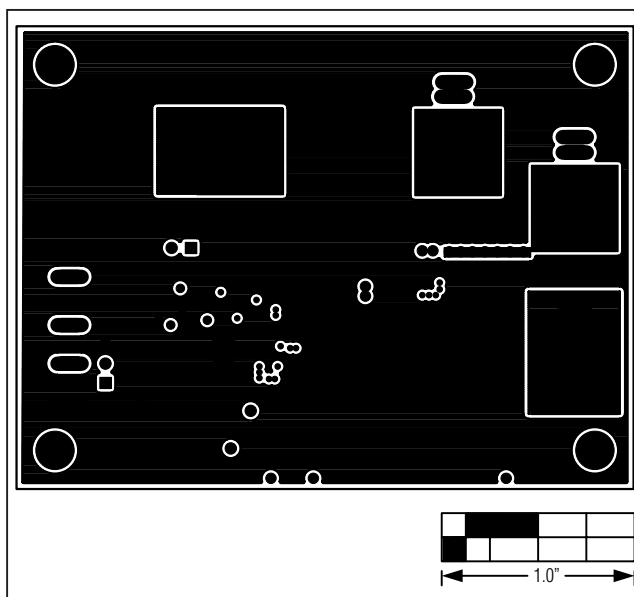

Figure 4. MAX15046B EV Kit PCB Layout—GND and VIN Layer 2

# MAX15046B Evaluation Kit

Evaluates: MAX15046B

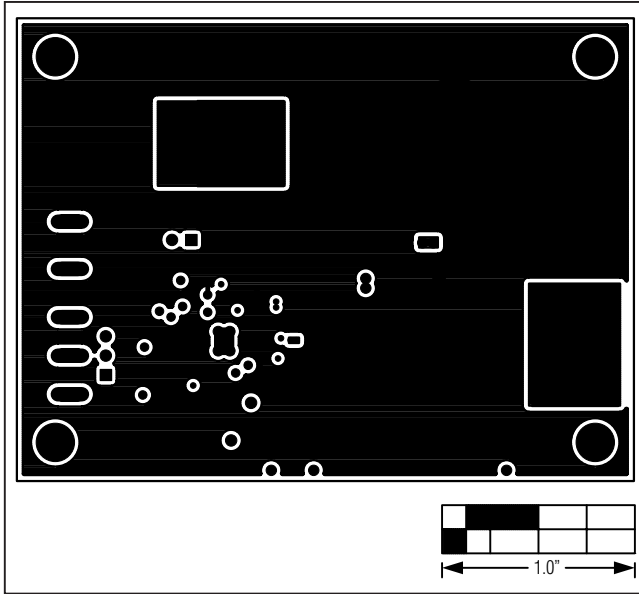

Figure 5. MAX15046B EV Kit PCB Layout—PGND Layer 3

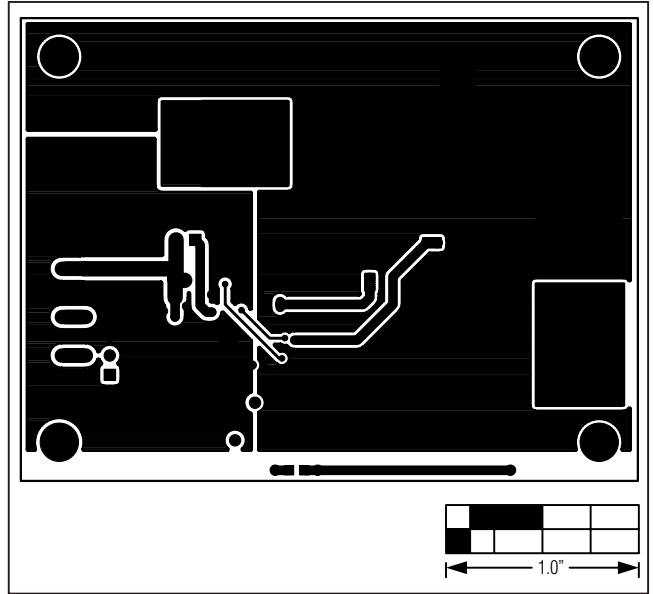

Figure 6. MAX15046B EV Kit PCB Layout—Solder Side

Maxim cannot assume responsibility for use of any circuitry other than circuitry entirely embodied in a Maxim product. No circuit patent licenses are implied. Maxim reserves the right to change the circuitry and specifications without notice at any time.

Maxim Integrated Products, 120 San Gabriel Drive, Sunnyvale, CA 94086 408-737-7600 \_\_\_\_\_ 7

## X-ON Electronics

Largest Supplier of Electrical and Electronic Components

*Click to view similar products for [Power Management IC Development Tools](#) category:*

*Click to view products by [Maxim](#) manufacturer:*

Other Similar products are found below :

[EVAL-ADM1168LQEBZ](#) [EVB-EP5348UI](#) [MIC23451-AAAYFL EV](#) [MIC5281YMME EV](#) [DA9063-EVAL](#) [ADP122-3.3-EVALZ](#) [ADP130-0.8-EVALZ](#) [ADP130-1.2-EVALZ](#) [ADP130-1.5-EVALZ](#) [ADP130-1.8-EVALZ](#) [ADP1712-3.3-EVALZ](#) [ADP1714-3.3-EVALZ](#) [ADP1715-3.3-EVALZ](#) [ADP1716-2.5-EVALZ](#) [ADP1740-1.5-EVALZ](#) [ADP1752-1.5-EVALZ](#) [ADP1828LC-EVALZ](#) [ADP1870-0.3-EVALZ](#) [ADP1871-0.6-EVALZ](#) [ADP1873-0.6-EVALZ](#) [ADP1874-0.3-EVALZ](#) [ADP1882-1.0-EVALZ](#) [ADP199CB-EVALZ](#) [ADP2102-1.25-EVALZ](#) [ADP2102-1.875EVALZ](#) [ADP2102-1.8-EVALZ](#) [ADP2102-2-EVALZ](#) [ADP2102-3-EVALZ](#) [ADP2102-4-EVALZ](#) [ADP2106-1.8-EVALZ](#) [ADP2147CB-110EVALZ](#) [AS3606-DB](#) [BQ24010EVM](#) [BQ24075TEVM](#) [BQ24155EVM](#) [BQ24157EVM-697](#) [BQ24160EVM-742](#) [BQ24296MEVM-655](#) [BQ25010EVM](#) [BQ3055EVM](#) [NCV891330PD50GEVB](#) [ISLUSBI2CKIT1Z](#) [LM2744EVAL](#) [LM2854EVAL](#) [LM3658SD-AEV/NOPB](#) [LM3658SDEV/NOPB](#) [LM3691TL-1.8EV/NOPB](#) [LM4510SDEV/NOPB](#) [LM5033SD-EVAL](#) [LP38512TS-1.8EV](#)