

EVALUATION KIT
AVAILABLE**MAXIM**

Linear Li+ Battery Charger with Integrated Pass FET and Thermal Regulation in 3mm x 3mm Thin DFN

General Description

The MAX1507 is an intelligent, stand-alone constant-current, constant-voltage (CCCV), thermally regulated linear charger for a single-cell lithium-ion (Li+) battery. The MAX1507 integrates the current-sense circuit, MOS pass element, and thermal-regulation circuitry, and also eliminates the reverse-blocking Schottky diode to create the simplest and smallest charging solution for hand-held equipment.

The MAX1507 functions as a stand-alone charger to control the charging sequence from the prequalification state through fast-charge, top-off charge, and full-charge indication.

Proprietary thermal-regulation circuitry limits the die temperature when fast charging or while exposed to high ambient temperatures, allowing maximum charging current without damaging the IC.

The MAX1507 achieves high flexibility by providing an adjustable fast-charge current and thermal regulation setpoints. Other features include the charging status (CHG) of the battery and an active-low control input ($\overline{\text{EN}}$).

The MAX1507 accepts a +4.25V to +13V supply, but disables charging when the input voltage exceeds +7V to protect against unqualified or faulty AC adapters. The MAX1507 operates over the extended temperature range (-40°C to +85°C) and is available in a compact 8-pin thermally enhanced 3mm x 3mm Thin DFN package with 0.8mm height.

Applications

Cellular and Cordless Phones
PDAs
Digital Cameras and MP3 Players
USB Appliances
Charging Cradles and Docks
Bluetooth™ Equipment

Pin Configuration

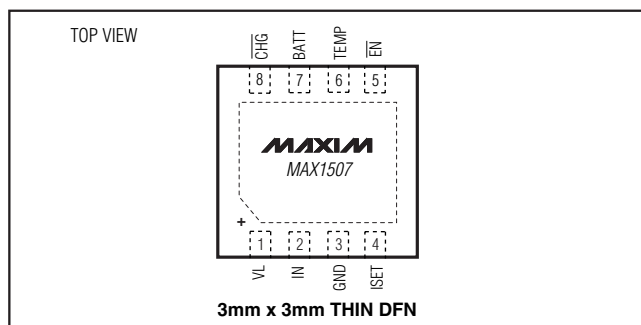

Bluetooth is a trademark of Ericsson.

Features

- ◆ Stand-Alone Linear 1-Cell Li+ Battery Charger
- ◆ No External FET, Reverse-Blocking Diode, or Current-Sense Resistor Required
- ◆ Programmable Fast-Charge Current (0.8A max)
- ◆ Proprietary Programmable Die-Temperature Regulation Control (+90°C, +100°C, and +130°C)
- ◆ +4.25V to +13V Input Voltage Range with Input Overvoltage Protection (OVP) Above +7V
- ◆ Charge-Current Monitor for Fuel Gauging
- ◆ Low Dropout Voltage—130mV at 0.425A
- ◆ Input Power-Source Detection Output (VL) and Charge-Enable Input ($\overline{\text{EN}}$)
- ◆ Soft-Start Limits Inrush Current
- ◆ Charge Status Output ($\overline{\text{CHG}}$) for LED or Microprocessor Interface
- ◆ Small 3mm x 3mm 8-Pin Thin DFN Package, 0.8mm High

Ordering Information

PART	TEMP RANGE	PIN-PACKAGE	TOP MARK
MAX1507ETA-T	-40°C to +85°C	8 Thin DFN-EP*	AGW
MAX1507ETA-T	-40°C to +85°C	8 Thin DFN-EP*	AGW

+ Denotes lead-free package.

*EP = Exposed paddle.

Typical Operating Circuit

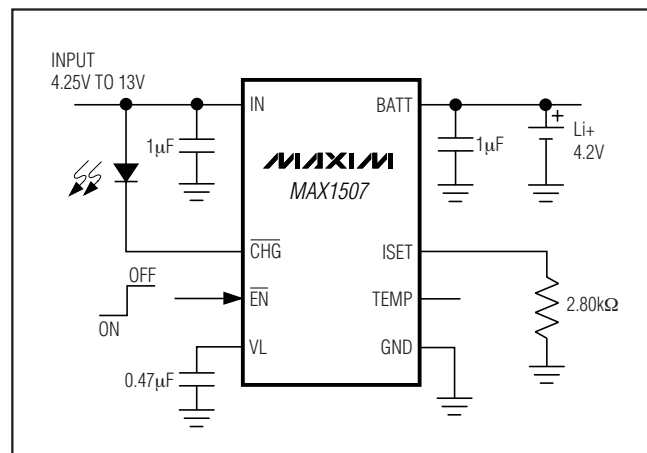
**MAXIM**

Maxim Integrated Products 1

For pricing, delivery, and ordering information, please contact Maxim/Dallas Direct! at 1-888-629-4642, or visit Maxim's website at www.maxim-ic.com.

MAX1507

Linear Li+ Battery Charger with Integrated Pass FET and Thermal Regulation in 3mm x 3mm Thin DFN

ABSOLUTE MAXIMUM RATINGS

IN, $\overline{\text{CHG}}$ to GND-0.3V to +14V
 VL, BATT, ISET, $\overline{\text{EN}}$, TEMP to GND-0.3V to +6V
 VL to IN.....-14V to +0.3V
 IN to BATT Continuous Current.....0.9A
 Continuous Power Dissipation ($T_A = +70^\circ\text{C}$)
 8-Pin TDFN (derate 24.4mW/°C above+70°C)1951mW

Short-Circuit Duration.....Continuous
 Operating Temperature Range-40°C to +85°C
 Junction Temperature+150°C
 Storage Temperature Range-65°C to +150°C
 Lead Temperature (soldering, 10s)+300°C

Stresses beyond those listed under "Absolute Maximum Ratings" may cause permanent damage to the device. These are stress ratings only, and functional operation of the device at these or any other conditions beyond those indicated in the operational sections of the specifications is not implied. Exposure to absolute maximum rating conditions for extended periods may affect device reliability.

ELECTRICAL CHARACTERISTICS

($V_{\text{IN}} = 5\text{V}$, $V_{\text{BATT}} = 4.0\text{V}$, $\text{TEMP} = \overline{\text{EN}} = \overline{\text{CHG}} = \text{unconnected}$, $R_{\text{ISET}} = 2.8\text{k}\Omega$ to GND, $C_{\text{VL}} = 0.47\mu\text{F}$, BATT bypassed to GND with $1\mu\text{F}$, $T_A = -40^\circ\text{C}$ to $+85^\circ\text{C}$, unless otherwise noted. Typical values are at $T_A = +25^\circ\text{C}$.) (Note 1)

PARAMETER	CONDITIONS		MIN	TYP	MAX	UNITS	
Input Voltage Range			0		13	V	
Input Operating Range			4.25		6.50	V	
$\overline{\text{ACOK}}$ Trip Point, IN	$V_{\text{IN}} - V_{\text{BATT}}$, V_{IN} rising		20	40	60	mV	
	$V_{\text{IN}} - V_{\text{BATT}}$, V_{IN} falling		15	30	45		
Overvoltage Lockout Trip Point	V_{IN} rising		6.5	7	7.5	V	
	V_{IN} hysteresis		0.11				
IN Input Current	Charging ($I_{\text{IN}} - I_{\text{BATT}}$)		1			mA	
	Disabled, $\overline{\text{EN}} = \text{VL}$		0.8				
	OFF state ($V_{\text{IN}} = V_{\text{BATT}} = 4.0\text{V}$)		0.065				
VL Output Voltage	$I_{\text{VL}} = 100\mu\text{A}$		3.3			V	
VL Load Regulation	$I_{\text{VL}} = 100\mu\text{A}$ to 2mA		-71			-200	mV
VL Temperature Coefficient	$I_{\text{VL}} = 100\mu\text{A}$		-2			mV/°C	
VL Undervoltage Lockout Trip Point	V_{IN} rising		2.95			V	
	Hysteresis		0.17				
BATT Input Current	$V_{\text{IN}} = 0$ to 4V		3			μA	
	$\overline{\text{EN}} = \text{VL}$		4				
Maximum RMS Charge Current			0.8			A	
Battery Regulation Voltage	$I_{\text{BATT}} = 0$	$T_A = 0^\circ\text{C}$ to $+85^\circ\text{C}$	4.162	4.2	4.238	V	
		$T_A = -40^\circ\text{C}$ to $+85^\circ\text{C}$	4.150	4.2	4.250		
BATT Removal Detection Threshold	V_{BATT} rising		4.4	4.67	4.9	V	

Linear Li+ Battery Charger with Integrated Pass FET and Thermal Regulation in 3mm x 3mm Thin DFN

ELECTRICAL CHARACTERISTICS (continued)

($V_{IN} = 5V$, $V_{BATT} = 4.0V$, $TEMP = \overline{EN} = \overline{CHG} =$ unconnected, $R_{ISET} = 2.8k\Omega$ to GND, $C_{VL} = 0.47\mu F$, BATT bypassed to GND with $1\mu F$, $T_A = -40^\circ C$ to $+85^\circ C$, unless otherwise noted. Typical values are at $T_A = +25^\circ C$.) (Note 1)

PARAMETER	CONDITIONS		MIN	TYP	MAX	UNITS	
BATT Removal Detection-Threshold Hysteresis			200			mV	
Minimum BATT Bypass Capacitance			1			$\mu F/A$	
Fast-Charge Current-Loop System Accuracy	$V_{BATT} = 3.5V$		478	520	562	mA	
Precharge Current System Accuracy	Percentage of the fast-charge current, $V_{BATT} = 2.2V$		5	10	15	%	
Die-Temperature-Regulation Set Point	TEMP = VL		130			°C	
	TEMP = floating		100				
	TEMP = GND		90				
V_{BATT} Precharge Threshold Voltage	V_{BATT} rising		2.3	2.5	2.7	V	
Current-Sense Amplifier Gain, ISET to IBATT in Fast Charge Mode	$I_{BATT} = 500mA$, $V_{ISET} = 1.4V$		0.880	0.958	1.035	mA/A	
Regulator Dropout Voltage ($V_{IN} - V_{BATT}$)	$V_{BATT} = 4.1V$, $I_{BATT} = 425mA$		130			200	mV
\overline{EN} Logic Input Low Voltage	$4.25V < V_{IN} < 6.5V$					0.52	V
\overline{EN} Logic Input High Voltage	$4.25V < V_{IN} < 6.5V$		1.3				V
\overline{EN} Internal Pulldown Resistor			100	200	400	$k\Omega$	
\overline{CHG} Output Low Current	$V_{\overline{CHG}} = 1V$		5	12	20	mA	
\overline{CHG} Output High Leakage Current	$V_{\overline{CHG}} = 13V$	$T_A = +25^\circ C$	1			μA	
		$T_A = +85^\circ C$	0.002				
Full Battery Detection Current Threshold (as a Percentage of the Fast-Charge Current)	I_{BATT} falling		5	10	15	%	

Note 1: Limits are 100% production tested at $T_A = +25^\circ C$. Limits over operating temperature range are guaranteed through correlation using statistical quality control (SQC) methods.

Linear Li+ Battery Charger with Integrated Pass FET and Thermal Regulation in 3mm x 3mm Thin DFN

Typical Operating Characteristics

($V_{IN} = 5V$, $V_{BATT} = 4.0V$, $TEMP = \overline{EN} = \overline{CHG} =$ unconnected, $R_{ISET} = 2.8k\Omega$ to GND, $C_{IN} = 1\mu F$, $C_{BATT} = 1\mu F$, $C_{VL} = 0.47\mu F$, $T_A = +25^\circ C$, unless otherwise noted.)

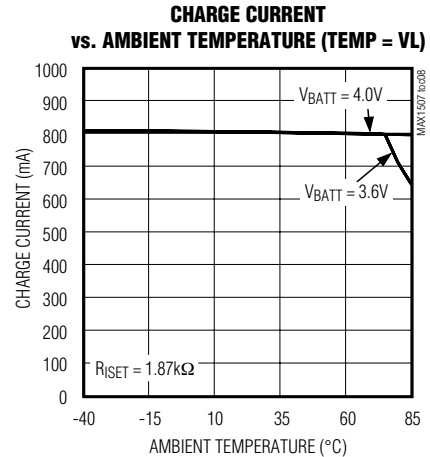
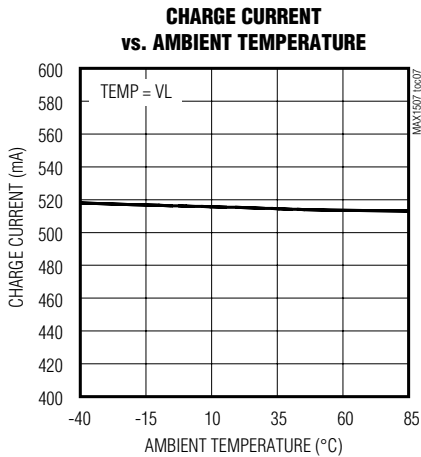
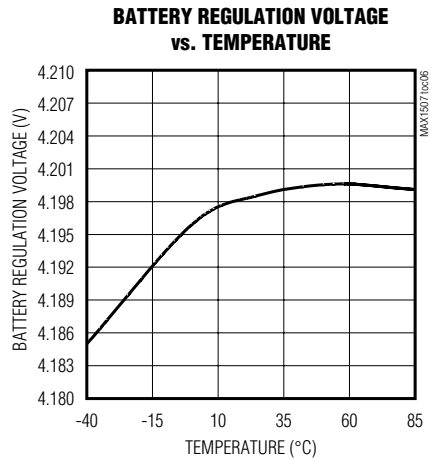
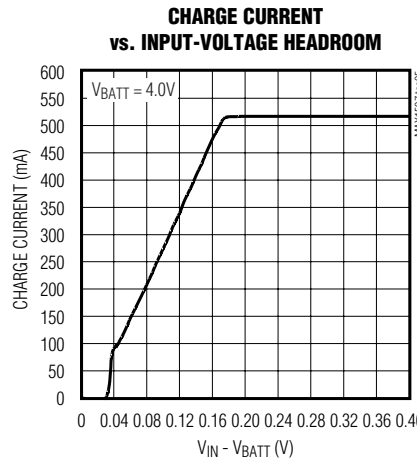
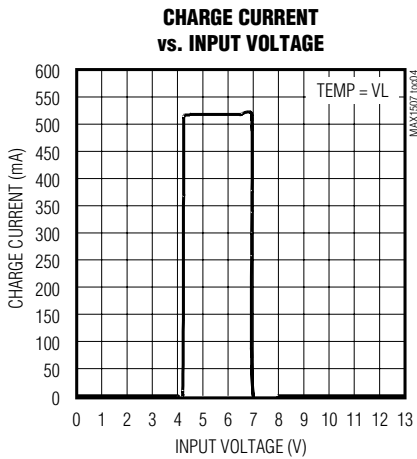
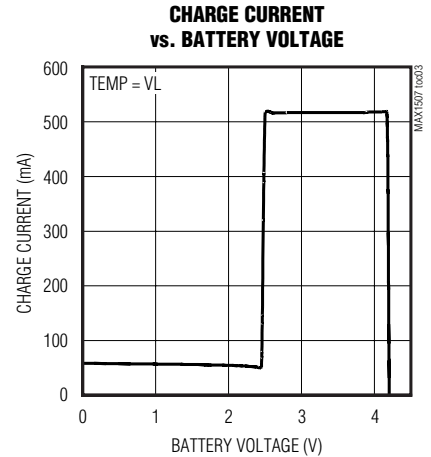
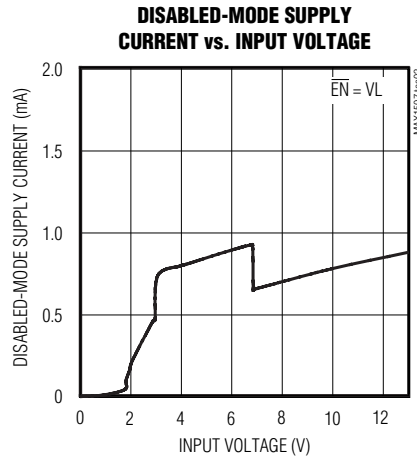
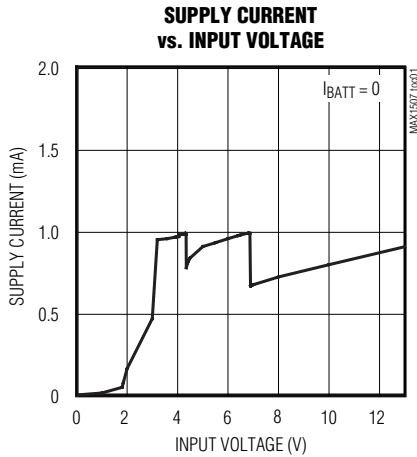

Linear Li+ Battery Charger with Integrated Pass FET and Thermal Regulation in 3mm x 3mm Thin DFN

MAX1507

Typical Operating Characteristics (continued)

($V_{IN} = 5V$, $V_{BATT} = 4.0V$, $TEMP = \overline{EN} = \overline{CHG} =$ unconnected, $R_{ISET} = 2.8k\Omega$ to GND, $C_{IN} = 1\mu F$, $C_{BATT} = 1\mu F$, $C_{VL} = 0.47\mu F$, $T_A = +25^\circ C$, unless otherwise noted.)

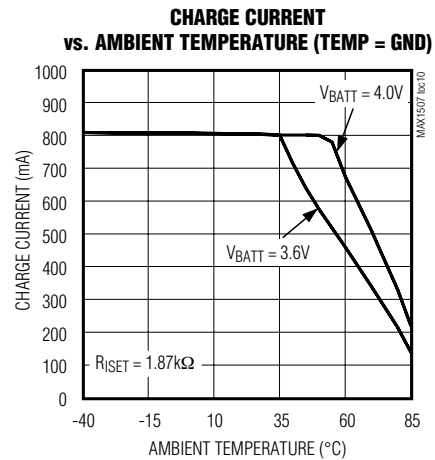
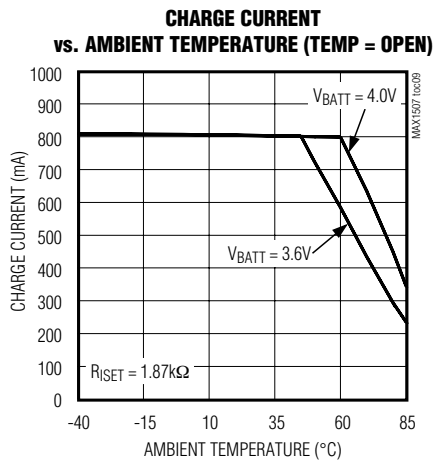

Pin Description

PIN	NAME	FUNCTION
1	VL	Internally Generated Logic Supply for Chip. Bypass VL to GND with a 0.47 μF capacitor.
2	IN	Input Supply Voltage. Bypass IN to GND with a 1 μF capacitor to improve line noise and transient rejection.
3	GND	Ground. Connect GND and exposed pad to a large copper trace for maximum power dissipation.
4	ISET	Charge-Current Program and Fast-Charge Current Monitor. Output current from ISET is 0.958mA per amp of battery charging current. The charging current is set by connecting a resistor from ISET to GND. Fast-charge current = $1461V / R_{ISET}\Omega$.
5	\overline{EN}	Logic-Level Enable Input. Drive \overline{EN} high to disable charger. Pull \overline{EN} low or float for normal operation. \overline{EN} has an internal 200k Ω pulldown resistor.
6	TEMP	Three-Level Input Pin. Connect TEMP to VL, GND, or leave floating. Sets maximum die temperature for thermal regulation loop. Connection to GND = +90 $^\circ C$, floating = +100 $^\circ C$, VL = +130 $^\circ C$. TEMP is Hi-Z during shutdown.
7	BATT	Li+ Battery Connection. Bypass BATT to GND with a capacitor of at least 1 μF per ampere of charge current.
8	\overline{CHG}	Charging Indicator, Open-Drain Output. \overline{CHG} goes low (and can turn on an LED) when charging begins. \overline{CHG} is high impedance when the battery current drops below 10% of the fast-charging current, or when \overline{EN} is high. Connect a pullup resistor to the μP 's I/O voltage when interfacing with a μP logic input.
—	PAD	Exposed Pad. Connect exposed pad to a large copper trace for maximum power dissipation. The pad is internally connected to GND.

Linear Li+ Battery Charger with Integrated Pass FET and Thermal Regulation in 3mm x 3mm Thin DFN

Detailed Description

The MAX1507 charger uses voltage, current, and thermal-control loops to charge a single Li+ cell and to protect the battery (Figure 1). When a Li+ battery with a cell voltage below 2.5V is inserted, the MAX1507 charger enters the prequalification stage where it precharges that cell with 10% of the user-programmed fast-charge current. The $\overline{\text{CHG}}$ indicator output is driven low (Figure 2) to indicate entry into the prequalification

state. Once the cell has passed 2.5V, the charger soft-starts before it enters the fast-charge stage. The fast-charge current level is programmed through a resistor from ISET to ground. As the battery voltage approaches 4.2V, the charging current is reduced. If the battery current drops to less than 10% of the fast-charging current, the $\overline{\text{CHG}}$ indicator goes high impedance, signaling the battery is fully charged. At this point the MAX1507 enters a constant voltage-regulation mode to

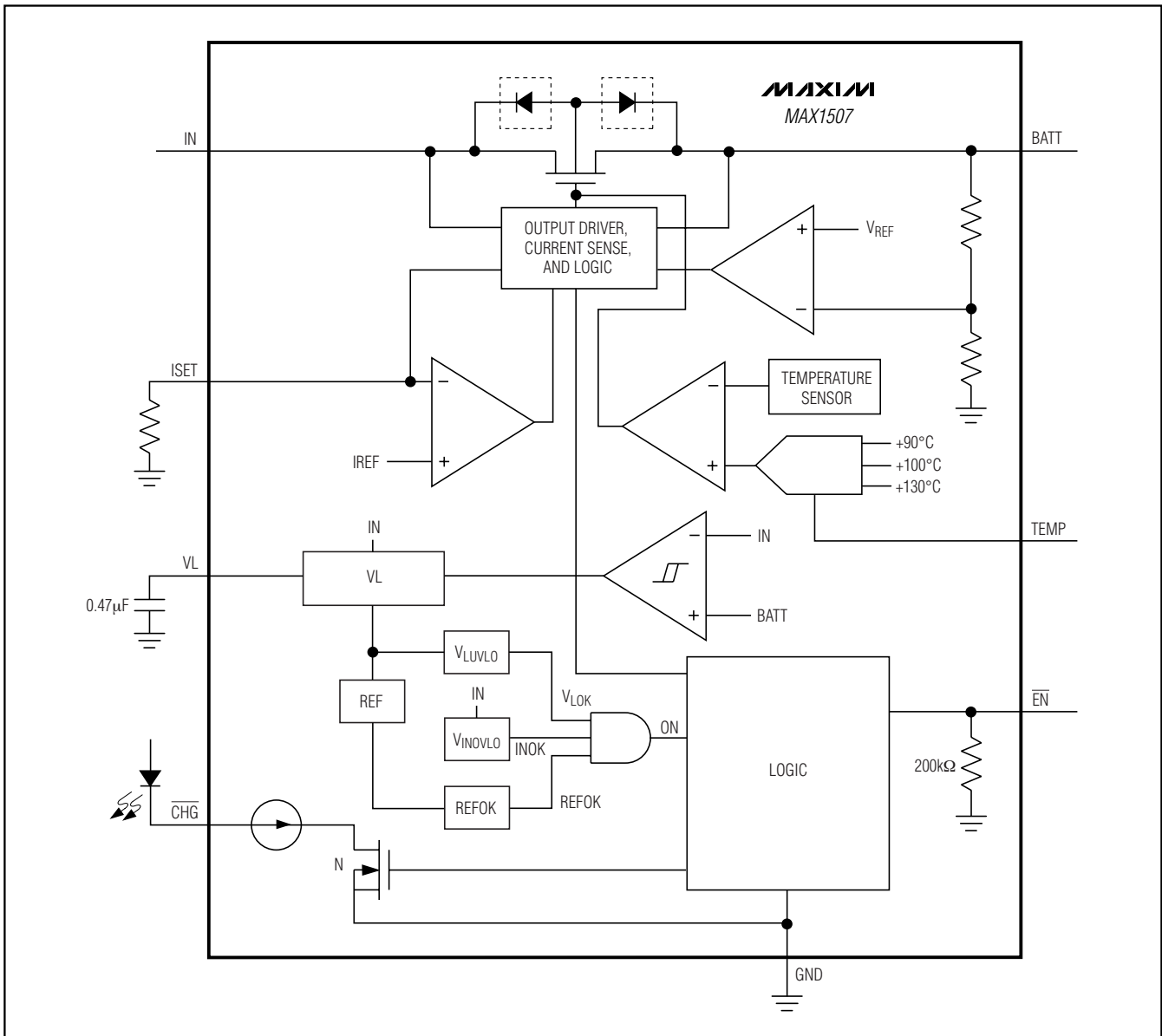

Figure 1. Functional Diagram

Linear Li+ Battery Charger with Integrated Pass FET and Thermal Regulation in 3mm x 3mm Thin DFN

MAX1507

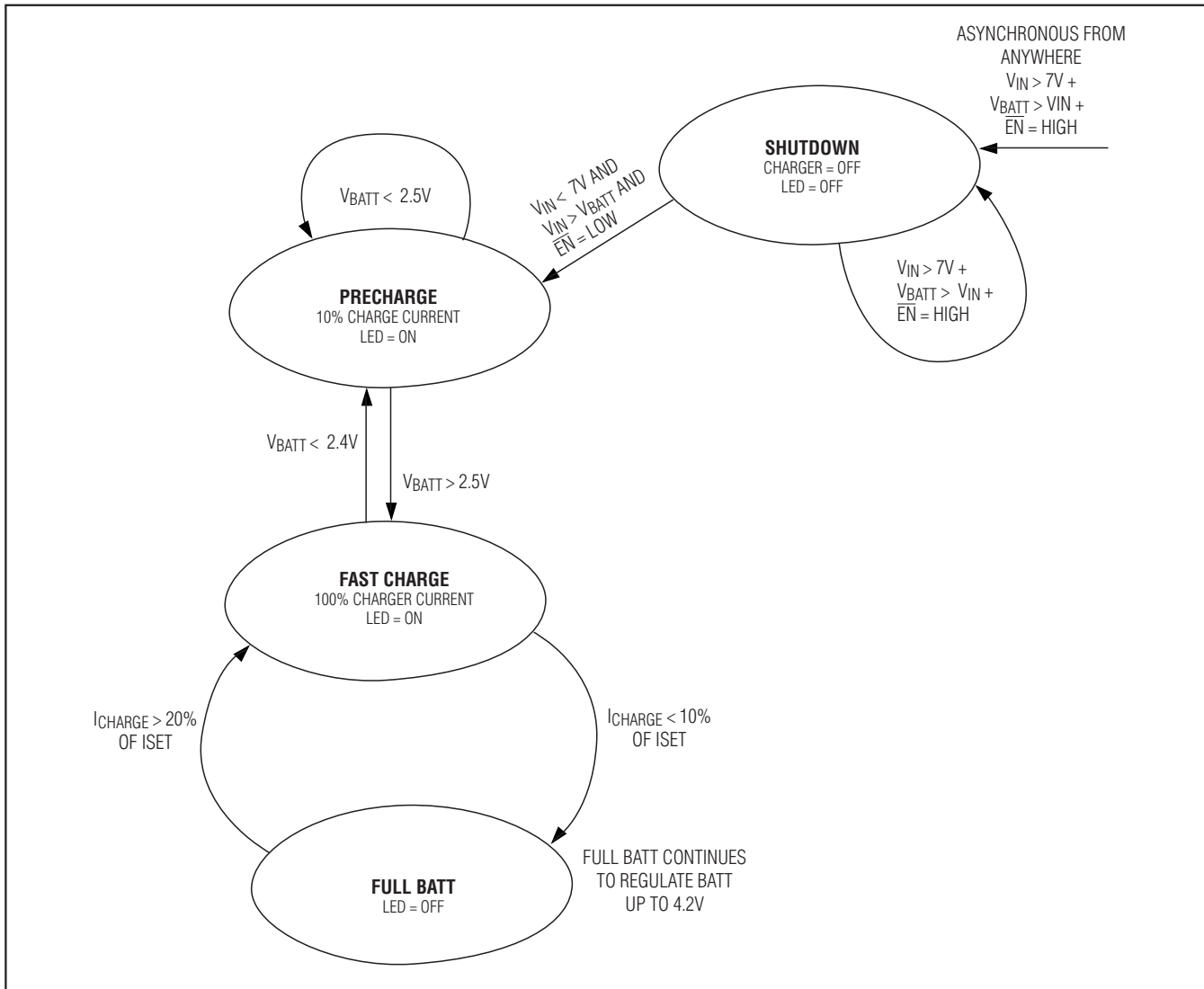

Figure 2. Charge State Diagram

maintain the battery at full charge. If, at any point while charging the battery, the die temperature approaches the user-selected temperature setting (TEMP pin), the MAX1507 reduces the charging current so the die temperature does not exceed the temperature-regulation set point.

The thermal-regulation loop limits the MAX1507 die temperature to the value selected by the TEMP input by reducing the charge current as necessary (see the *Thermal-Regulation Selection* section). This feature not only protects the MAX1507 from overheating, but also allows higher charge current without risking damage to the system.

\overline{EN} Charger Enable Input

\overline{EN} is a logic input (active low) to enable the charger. Drive \overline{EN} low, leave floating, or connect to GND to enable the charger control circuitry. Drive \overline{EN} high to disable the charger control circuitry. \overline{EN} has a 200k Ω internal pulldown resistance.

VL Internal Voltage Regulator

The MAX1507 linear charger contains an internal linear regulator available on the VL output pin. VL requires a 0.47 μ F ceramic bypass capacitor to GND. VL is regulated to 3.3V whenever the input voltage is above 3.5V.

Linear Li+ Battery Charger with Integrated Pass FET and Thermal Regulation in 3mm x 3mm Thin DFN

CHG Charge Indicator Output

CHG is an open-drain current source for indicating charge status. Table 1 describes the state of CHG during different stages of operation.

CHG is a nominal 12mA current source suitable for driving a charge-indication LED. If the MAX1507 is used in conjunction with a microprocessor, a pullup resistor to the logic I/O voltage allows CHG to indicate charge status to the μP instead of driving an LED.

Soft-Start

An analog soft-start algorithm activates when entering fast-charge mode. When the prequalification state is complete (V_{BATT} exceeds +2.5V), the charging current ramps up in 3ms to the full charging current. This reduces the inrush current on the input supply.

Applications Information

Charge-Current Selection

The maximum charging current is programmed by an external R_{ISET} resistor connected from ISET to GND. Select the R_{ISET} value based on the following formula:

$$I_{\text{FAST}} = 1461\text{V} / R_{\text{ISET}}\Omega$$

where I_{FAST} is in amps and R_{ISET} is in ohms. ISET can also be used to monitor the fast-charge current level. The output current from the ISET pin is 0.958mA per amp of charging current. The output voltage at ISET is proportional to the charging current as follows:

$$V_{\text{ISET}} = (I_{\text{CHG}} \times R_{\text{ISET}}) / 1044$$

The voltage at ISET is nominally 1.4V at the selected fast-charge current, and falls with charging current as the cell becomes fully charged.

Thermal-Regulation Selection

Set the regulated die temperature of the MAX1507 with the TEMP three-level logic input. The MAX1507 reduces the charge current to limit the die temperature

to the value set by TEMP. The MAX1507 operates normally while the thermal loop is active. An active thermal loop does not indicate a fault condition. TEMP allows the MAX1507 to maximize the charge current while providing protection against excessive power dissipation.

Connect TEMP to GND to regulate the die temperature at +90°C. Leave TEMP floating to regulate the die temperature at +100°C. Connect TEMP to VL to regulate the die temperature at +130°C.

Capacitor Selection

Connect a ceramic capacitor from BATT to GND for proper stability. Use a 1 μF X5R ceramic capacitor for most applications.

Connect a 1 μF ceramic capacitor from IN to GND. Use a larger input bypass capacitor for high input voltages or high charging currents to reduce supply noise.

Connect a 0.47 μF ceramic capacitor from VL to GND.

Thermal Considerations

The MAX1507 is in a thermally enhanced thin DFN package with exposed paddle. Connect the exposed paddle of the MAX1507 to a large copper ground plane to provide a thermal contact between the device and the circuit board. The exposed paddle transfers heat away from the device, allowing the MAX1507 to charge the battery with maximum current, while minimizing the increase in die temperature.

DC Input Sources

The MAX1507 operates from well-regulated DC sources. The full-charging input-voltage range is 4.25V to 7V. The device can stand up to 13V on the input without damage to the IC. If V_{IN} is greater than 7V, then the MAX1507 stops charging.

An appropriate power supply must provide at least 4.25V when sourcing the desired peak charging current. It also must stay below 6.5V when unloaded.

Table 1. CHG States

EN	V _{IN}	V _{BATT}	I _{BATT}	CHG	STATE
X	V _{BATT}	V _{IN}	0	Hi-Z	Shutdown
Low	4.25V ≤ V _{IN} ≤ 7V	< 2.5V	10% of I _{FAST}	Low	Prequalification
Low	4.25V ≤ V _{IN} ≤ 7V	≥ 2.5V	I _{FAST} *	Low	Fast Charge
Low	4.25V ≤ V _{IN} ≤ 7V	4.2V	10% of I _{FAST}	Hi-Z	Full Charge
Low	>7V	X	0	Hi-Z	Overvoltage
High	X	X	0	Hi-Z	Disabled

X = Don't care.

*I_{FAST} is reduced as necessary to maintain the die temperature set by the TEMP input.

Linear Li+ Battery Charger with Integrated Pass FET and Thermal Regulation in 3mm x 3mm Thin DFN

Application Circuits

Stand-Alone Li+ Charger

The MAX1507 provides a complete Li+ charging solution. The *Typical Application Circuit* on the front page shows the MAX1507 as a stand-alone Li+ battery charger. The 2.8kΩ resistor connected to ISET sets a charging current of 520mA. The LED indicates when either fast-charge or precharge qualification has begun. When the battery is full, the LED turns off.

Microprocessor-Interfaced Charger

Figure 3 shows the MAX1507 as a μP-cooperated Li+ battery charger. The MAX1507 starts charging the battery when \overline{EN} is low. The μP can drive \overline{EN} high to disable the charger. Use a logic-biased NPN transistor as an inverter circuit to generate an $\overline{AC_ON}$ signal for the system to detect the presence of an input supply. CHG can be used to detect the charge status of a battery. By monitoring V_{ISET} , the system can measure the charge current.

USB-Powered Li+ Charger

The universal serial bus (USB) provides a high-speed serial communication port as well as power for the remote device. The MAX1507 can be configured to charge its battery at the highest current possible from the host port. Figure 4 shows the MAX1507 as a USB battery charger. To make the circuit compatible with either 100mA or 500mA USB ports, the circuit initializes at 95mA charging current. The microprocessor then interrogates the host to determine its current capability. If the host port is capable, the charging current is increased to 435mA. The 435mA current was chosen to avoid exceeding the 500mA USB specification.

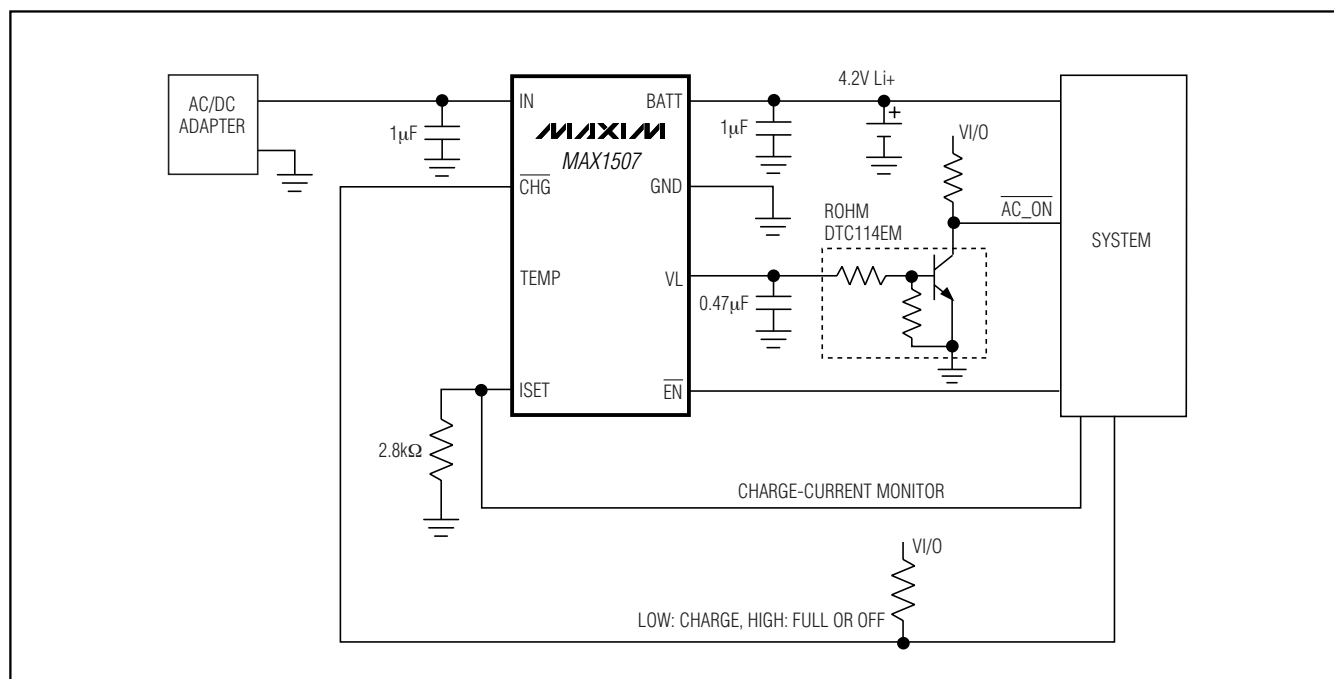

Figure 3. μP Interfaced Li+ Battery Charger

Linear Li+ Battery Charger with Integrated Pass FET and Thermal Regulation in 3mm x 3mm Thin DFN

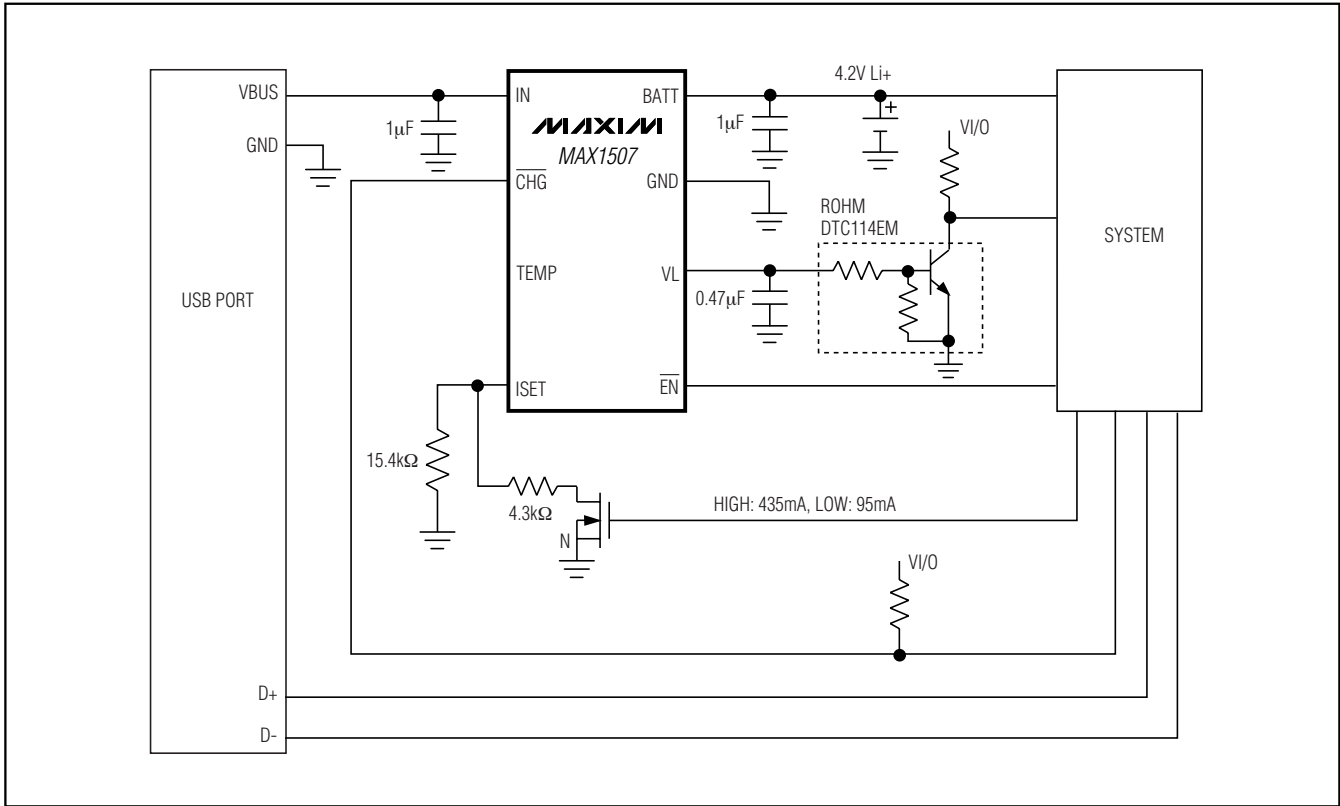

Figure 4. USB Battery Charger

Layout and Bypassing

Connect a 1µF ceramic input capacitor as close to the device as possible. Provide a large copper GND plane to allow the exposed paddle to sink heat away from the device. Connect the battery to BATT as close to the device as possible to provide accurate battery voltage sensing. Make all high-current traces short and wide to minimize voltage drops. For an example layout, refer to the MAX1507/MAX1508 evaluation kit layout.

Chip Information

TRANSISTOR COUNT: 1812

PROCESS: BiCMOS

Linear Li+ Battery Charger with Integrated Pass FET and Thermal Regulation in 3mm x 3mm Thin DFN

Package Information

(The package drawing(s) in this data sheet may not reflect the most current specifications. For the latest package outline information, go to www.maxim-ic.com/packages.)

MAX1507

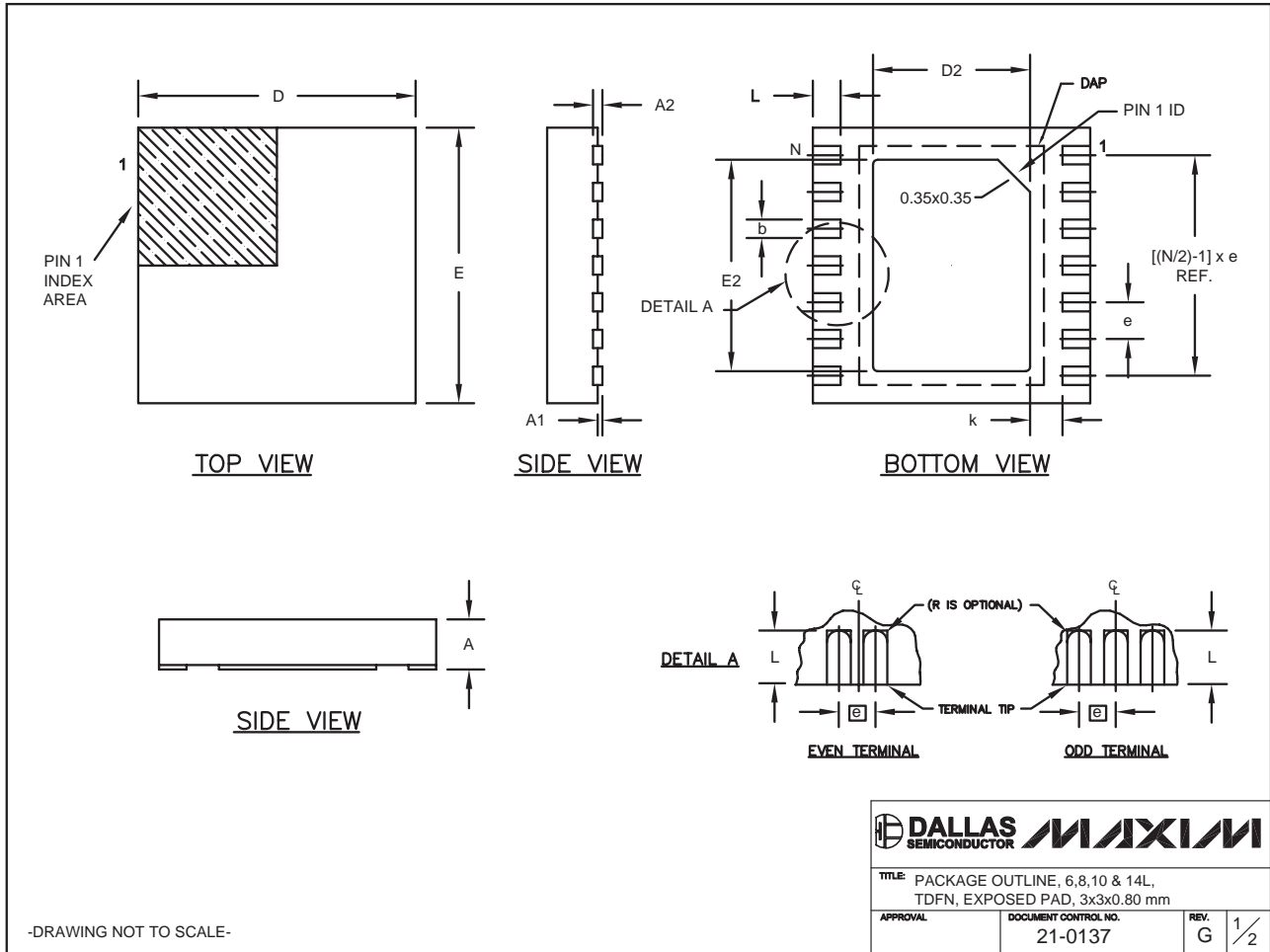

Linear Li+ Battery Charger with Integrated Pass FET and Thermal Regulation in 3mm x 3mm Thin DFN

Package Information (continued)

(The package drawing(s) in this data sheet may not reflect the most current specifications. For the latest package outline information, go to www.maxim-ic.com/packages.)

COMMON DIMENSIONS		
SYMBOL	MIN.	MAX.
A	0.70	0.80
D	2.90	3.10
E	2.90	3.10
A1	0.00	0.05
L	0.20	0.40
k	0.25 MIN.	
A2	0.20 REF.	

PACKAGE VARIATIONS								
PKG. CODE	N	D2	E2	e	JEDEC SPEC	b	[(N/2)-1] x e	DOWNBONDS ALLOWED
T633-1	6	1.50±0.10	2.30±0.10	0.95 BSC	MO229 / WEEA	0.40±0.05	1.90 REF	NO
T633-2	6	1.50±0.10	2.30±0.10	0.95 BSC	MO229 / WEEA	0.40±0.05	1.90 REF	NO
T833-1	8	1.50±0.10	2.30±0.10	0.65 BSC	MO229 / WEEC	0.30±0.05	1.95 REF	NO
T833-2	8	1.50±0.10	2.30±0.10	0.65 BSC	MO229 / WEEC	0.30±0.05	1.95 REF	NO
T833-3	8	1.50±0.10	2.30±0.10	0.65 BSC	MO229 / WEEC	0.30±0.05	1.95 REF	YES
T1033-1	10	1.50±0.10	2.30±0.10	0.50 BSC	MO229 / WEED-3	0.25±0.05	2.00 REF	NO
T1433-1	14	1.70±0.10	2.30±0.10	0.40 BSC	---	0.20±0.05	2.40 REF	YES
T1433-2	14	1.70±0.10	2.30±0.10	0.40 BSC	---	0.20±0.05	2.40 REF	NO

NOTES:

- ALL DIMENSIONS ARE IN mm. ANGLES IN DEGREES.
- COPLANARITY SHALL NOT EXCEED 0.08 mm.
- WARPAGE SHALL NOT EXCEED 0.10 mm.
- PACKAGE LENGTH/PACKAGE WIDTH ARE CONSIDERED AS SPECIAL CHARACTERISTIC(S).
- DRAWING CONFORMS TO JEDEC MO229, EXCEPT DIMENSIONS "D2" AND "E2", AND T1433-1 & T1433-2.
- "N" IS THE TOTAL NUMBER OF LEADS.
- NUMBER OF LEADS SHOWN ARE FOR REFERENCE ONLY.

-DRAWING NOT TO SCALE-

		
TITLE: PACKAGE OUTLINE, 6, 8, 10 & 14L, TDFN, EXPOSED PAD, 3x3x0.80 mm		
APPROVAL	DOCUMENT CONTROL NO.	REV.
	21-0137	G 2/2

Maxim cannot assume responsibility for use of any circuitry other than circuitry entirely embodied in a Maxim product. No circuit patent licenses are implied. Maxim reserves the right to change the circuitry and specifications without notice at any time.

12 **Maxim Integrated Products, 120 San Gabriel Drive, Sunnyvale, CA 94086 408-737-7600**

X-ON Electronics

Largest Supplier of Electrical and Electronic Components

Click to view similar products for [Battery Management](#) category:

Click to view products by [Maxim](#) manufacturer:

Other Similar products are found below :

[MP26121DQ-LF-P](#) [NCP1855FCCT1G](#) [FAN54063UCX](#) [LC05132C01NMTTTG](#) [SN2040DSQR](#) [ME4075AM5G](#) [AP5054HTCER](#) [XPD977B](#)
[XPD977B18](#) [4056H](#) [DW01](#) [DW06](#) [CM1002-UD](#) [CM1002-W](#) [CM1002-X](#) [CM1002-Y](#) [CM1006-B](#) [CM1006-Q](#) [CM1006-WB](#) [CM1006-LCD](#)
[CM1006-LBD](#) [CM1006-WF](#) [CM1006-LF](#) [CM1006-WG](#) [CM1006-WH](#) [CM1006-LG](#) [CM1003-S02BD](#) [CM1003-S09EA](#) [CM1003-S10ED](#)
[CM1003-S11ED](#) [CM1003-S12BC](#) [CM1003-S13CC](#) [CM1003-S24BC](#) [CM1003-S26BC](#) [CM1003-WAD](#) [CM1003-BBD](#) [CM1003-BFD](#)
[CM1003-BND](#) [CM1003-BLD](#) [CM1003-DAD](#) [CM1003-BMD](#) [CM1003-BPD](#) [CM1003-BKD](#) [CM1003-BAE](#) [CM1003-BHE](#) [CM1102B-FF](#)
[CM1102B-FD](#) [CM1102B-GD](#) [CM1112-DAE](#) [CM1112-DBE](#)