



# 6-Channel, Flash-Configurable System Manager with Nonvolatile Fault Registers

## General Description

The MAX16067 flash-configurable system manager monitors and sequences multiple system voltages. The MAX16067 manages up to six system voltages simultaneously. The MAX16067 integrates an analog-to-digital converter (ADC) and configurable outputs for sequencing power supplies. Device configuration information, including overvoltage and undervoltage limits, time delay settings, and the sequencing order is stored in nonvolatile flash memory. During a fault condition, fault flags and channel voltages can be automatically stored in the nonvolatile flash memory for later readback.

The internal 1% accurate, 10-bit ADC measures each input and compares the result to one overvoltage and one undervoltage limit. A fault signal asserts when a monitored voltage falls outside the set limits.

The MAX16067 supports a power-supply voltage of up to 14V and can be powered directly from the 12V intermediate bus in many systems.

The integrated sequencer provides precise control over the power-up and power-down order of up to six power supplies. Three outputs (EN\_OUT1 to EN\_OUT3) are configurable with charge-pump outputs to directly drive external n-channel MOSFETs.

The MAX16067 includes six programmable general-purpose inputs/outputs (GPIOs). GPIOs are flash configurable as a fault output, as a watchdog input or output, or as a manual reset.

The MAX16067 features nonvolatile fault memory for recording information during system shutdown events. The fault logger records a failure in the internal flash and sets a lock bit protecting the stored fault data from accidental erasure.

An SMBus™ or a JTAG serial interface configures the MAX16067. The MAX16067 is available in a 32-pin, 5mm x 5mm, TQFN package and is fully specified over the -40°C to +85°C extended temperature range.

## Features

- ◆ Operates from 2.8V to 14V
- ◆ 1% Accurate, 10-Bit ADC Monitors 6 Voltage Inputs
- ◆ Analog EN Monitoring Input
- ◆ 6 Monitored Inputs with Overvoltage and Undervoltage Limits
- ◆ Nonvolatile Fault Event Logger
- ◆ Power-Up and Power-Down Sequencing Capability
- ◆ 6 Outputs for Sequencing/Power-Good Indicators
- ◆ 3 Configurable Charge-Pump Outputs
- ◆ Six General-Purpose Inputs/Outputs Configurable as:
  - Dedicated Fault Output
  - Watchdog Timer Function
  - Manual Reset
  - SMBus Alert
  - Fault Propagation Input/Output
- ◆ SMBus and JTAG Interface
- ◆ Supports Cascading with MAX16065/MAX16066
- ◆ Flash-Configurable Time Delays and Thresholds
- ◆ -40°C to +85°C Extended Operating Temperature Range

## Applications

Networking Equipment  
 Telecom Equipment (Base Stations, Access)  
 Storage/RAID Systems  
 Servers

*Typical Operating Circuit appears at end of data sheet.*

## Ordering Information/Selector Guide

PART	PIN-PACKAGE	VOLTAGE-DETECTOR INPUTS	GENERAL-PURPOSE INPUTS/OUTPUTS	SEQUENCING OUTPUTS
MAX16067ETJ+	32 TQFN-EP*	6	6	6

**Note:** This device is specified over the -40°C to +85°C extended temperature range.

+Denotes a lead(Pb)-free/RoHS-compliant package.

\*EP = Exposed pad.

SMBus is a trademark of Intel Corp.



# 6-Channel, Flash-Configurable System Manager with Nonvolatile Fault Registers

## ABSOLUTE MAXIMUM RATINGS

V <sub>CC</sub> to GND	-0.3V to +15V
MON_, SCL, SDA, A0 to GND	-0.3V to +6V
EN, TCK, TMS, TDI to GND	-0.3V to +4V
TDO to GND	-0.3V to (V <sub>DBP</sub> + 0.3V)
EN_OUT1, EN_OUT2, EN_OUT3 (configured as open-drain) to GND	-0.3V to +15V
EN_OUT1, EN_OUT2, EN_OUT3 (configured as charge pump) to GND	-0.3V to +15V
EN_OUT4, EN_OUT5, EN_OUT6, RESET, GPIO_ (configured as open-drain) to GND	-0.3V to +6V
EN_OUT_, RESET, GPIO_ (configured as push-pull) to GND	-0.3V to (V <sub>DBP</sub> + 0.3V)

DBP, ABP to GND	-0.3V to minimum of (4V and (V <sub>CC</sub> + 0.3V))
Continuous Current (all other pins)	±20mA
Continuous Current (GND, pin 5)	±30mA
Continuous Power Dissipation (T <sub>A</sub> = +70°C) 32-Pin TQFN (derate 34.5mW/°C above +70°C)	2759mW*
Thermal Resistance (Note 1)	
θ <sub>JA</sub>	29°C/W
θ <sub>JC</sub>	2°C/W
Operating Temperature Range	-40°C to +85°C
Junction Temperature	+150°C
Storage Temperature Range	-65°C to +150°C
Lead Temperature (soldering, 10s)	+300°C
Soldering Temperature (reflow)	+260°C

\*As per JEDEC 51 Standard, Multilayer Board (PCB).

**Note 1:** Package thermal resistances were obtained using the method described in JEDEC specification JESD51-7, using a four-layer board. For detailed information on package thermal considerations, refer to [www.maxim-ic.com/thermal-tutorial](http://www.maxim-ic.com/thermal-tutorial).

Stresses beyond those listed under "Absolute Maximum Ratings" may cause permanent damage to the device. These are stress ratings only, and functional operation of the device at these or any other conditions beyond those indicated in the operational sections of the specifications is not implied. Exposure to absolute maximum rating conditions for extended periods may affect device reliability.

## ELECTRICAL CHARACTERISTICS

(V<sub>CC</sub> = 2.8V to 14V, T<sub>A</sub> = T<sub>J</sub> = -40°C to +85°C, unless otherwise specified. Typical values are at V<sub>ABP</sub> = V<sub>DBP</sub> = V<sub>CC</sub> = 3.3V, T<sub>A</sub> = +25°C.) (Note 2)

PARAMETER	SYMBOL	CONDITIONS	MIN	TYP	MAX	UNITS
Operating Voltage Range	V <sub>CC</sub>	RESET output asserted low	1.2		14	V
			2.8			
Undervoltage Lockout	V <sub>UVLO</sub>	Minimum voltage on V <sub>CC</sub> to ensure the device is flash configurable			2.7	V
Undervoltage Lockout Hysteresis	UVLOHYS			55		mV
Minimum Flash Operating Voltage	V <sub>FLASH</sub>	Minimum voltage on V <sub>CC</sub> to ensure flash erase and write operations	2.7			V
Supply Current	I <sub>CC1</sub>	No load on any output		2.8	4	mA
	I <sub>CC2</sub>	No load on any output, during flash writing cycle		7.7	14	
		V <sub>CC</sub> = V <sub>ABP</sub> = V <sub>DBP</sub> = 3.6V (Note 3)			5	
DBP Regulator Voltage	V <sub>DBP</sub>	V <sub>CC</sub> = 5V, C <sub>DBP</sub> = 1μF, no load	2.8	3	3.2	V
ABP Regulator Voltage	V <sub>ABP</sub>	V <sub>CC</sub> = 5V, C <sub>ABP</sub> = 1μF, no load	2.85	3	3.15	V
Boot Time	t <sub>BOOT</sub>	V <sub>CC</sub> > V <sub>UVLO</sub>		100	200	μs
Flash Writing Time		8-byte word		122		ms
Internal Timing Accuracy		(Note 4)	-10		+10	%
<b>ADC</b>						
Resolution				10		Bits
Gain Error	ADCGAIN	T <sub>A</sub> = +25°C			0.35	%
		T <sub>A</sub> = -40°C to +85°C			0.75	
Offset Error	ADCOFF				1.50	LSB
Integral Nonlinearity	ADCINL				1	LSB

# 6-Channel, Flash-Configurable System Manager with Nonvolatile Fault Registers

## ELECTRICAL CHARACTERISTICS (continued)

(VCC = 2.8V to 14V, TA = TJ = -40°C to +85°C, unless otherwise specified. Typical values are at VABP = VDBP = VCC = 3.3V, TA = +25°C.) (Note 2)

PARAMETER	SYMBOL	CONDITIONS	MIN	TYP	MAX	UNITS
Differential Nonlinearity	ADCDNL				1	LSB
ADC Total Monitoring Cycle Time	tCYCLE	Monitoring all 6 inputs, no MON_ fault detected		24	30	μs
ADC MON_ Ranges	ADCRNG	MON_ range set to '00'		5.552		V
		MON_ range set to '01'		2.776		
		MON_ range set to '10'		1.388		
ADC LSB Step Size	ADC_LSB	MON_ range set to '00'		5.42		mV
		MON_ range set to '01'		2.71		
		MON_ range set to '10'		1.35		
ADC Input Leakage Current					1	μA
<b>ENABLE INPUT (EN)</b>						
EN Input-Voltage Threshold	VTH_EN_R	EN voltage rising		1.24		V
	VTH_EN_F	EN voltage falling	1.195	1.215	1.235	
EN Input Current	IEN		-0.5		+0.5	μA
EN Input-Voltage Range			0		3.6	V
<b>OUTPUTS (EN_OUT_, RESET, GPIO_)</b>						
Output Voltage Low	VOL	ISINK = 2mA			0.4	V
		ISINK = 10mA, GPIO_ only			0.7	
		VCC = 1.2V, ISINK = 100μA (RESET only)			0.3	
Maximum Output Sink Current		Total current into EN_OUT_, RESET, GPIO_, VCC = 3.3V			30	mA
Output-Voltage High (Push-Pull)	VOH	ISOURCE = 100μA	2.4			V
Output-Voltage High (EN_OUT1, EN_OUT2, EN_OUT3 Configured as Charge Pumps)	VOH_CP	IEN_OUT_ = 1μA	11	11.7	13	V
EN_OUT_ Pullup Current (Charge Pump)	I_CH_UP	VEN_OUT_ = 1V	5.4	7.9		μA
Output Leakage Current (Open Drain)	IOUT_LKG				1	μA
		EN_OUT1, EN_OUT2, EN_OUT3 > 11.8V			5	
<b>INPUTS (A0, GPIO_)</b>						
Input Logic-Low	VIL				0.8	V
Input Logic-High	VIH		2.0			V
WDI Pulse Width	tWDI		100			ns
MR Pulse Width	tMR		2			μs
<b>SMBus INTERFACE</b>						
Logic-Input Low Voltage	VIL	Input voltage falling			0.8	V
Logic-Input High Voltage	VIH	Input voltage rising	2.0			V
Input Leakage Current		VCC shorted to GND, VMON_ = 0 or 6V	-1		+1	μA
Output Sink Current	VOL	ISINK = 3mA			0.4	V
Input Capacitance	CIN			5		pF

# 6-Channel, Flash-Configurable System Manager with Nonvolatile Fault Registers

## ELECTRICAL CHARACTERISTICS (continued)

( $V_{CC} = 2.8V$  to  $14V$ ,  $T_A = T_J = -40^{\circ}C$  to  $+85^{\circ}C$ , unless otherwise specified. Typical values are at  $V_{ABP} = V_{DBP} = V_{CC} = 3.3V$ ,  $T_A = +25^{\circ}C$ .) (Note 2)

PARAMETER	SYMBOL	CONDITIONS	MIN	TYP	MAX	UNITS
<b>SMBus TIMING</b>						
Serial-Clock Frequency	f <sub>SCL</sub>				400	kHz
Bus Free Time Between STOP and START Condition	t <sub>BUF</sub>		1.3			μs
START Condition Setup Time	t <sub>SU:STA</sub>		0.6			μs
START Condition Hold Time	t <sub>HD:STA</sub>		0.6			μs
STOP Condition Setup Time	t <sub>SU:STO</sub>		0.6			μs
Clock Low Period	t <sub>LOW</sub>		1.3			μs
Clock High Period	t <sub>HIGH</sub>		0.6			μs
Data Setup Time	t <sub>SU:DAT</sub>		100			ns
Output Fall Time	t <sub>OF</sub>	10pF ≤ C <sub>BUS</sub> ≤ 400pF			250	ns
Data Hold Time	t <sub>HD:DAT</sub>	From 50% SCL falling to SDA change	Receive	0.15		μs
			Transmit	0.3	0.9	
Pulse Width of Spike Suppressed	t <sub>SP</sub>			250		ns
SMBus Timeout	t <sub>TIMEOUT</sub>	SMBCLK time low for reset	22		35	ms
<b>JTAG INTERFACE</b>						
TDI, TMS, TCK Logic-Low Input Voltage	V <sub>IL</sub>	Input voltage falling			0.8	V
TDI, TMS, TCK Logic-High Input Voltage	V <sub>IH</sub>	Input voltage rising	2.0			V
TDO Logic-Output Low Voltage	V <sub>OL_TDO</sub>	I <sub>SINK</sub> = 3mA			0.4	V
TDO Logic-Output High Voltage	V <sub>OH_TDO</sub>	I <sub>SOURCE</sub> = 200μA	2.4			V
TDI, TMS Pullup Resistors	R <sub>JPU</sub>	Pullup to DBP	30	50	65	kΩ
I/O Capacitance	C <sub>I/O</sub>			5		pF
TCK Clock Period	t <sub>1</sub>				1000	ns
TCK High/Low Time	t <sub>2, t3</sub>		50	500		ns
TCK to TMS, TDI Setup Time	t <sub>4</sub>		15			ns
TCK to TMS, TDI Hold Time	t <sub>5</sub>		15			ns
TCK to TDO Delay	t <sub>6</sub>				500	ns
TCK to TDO High-Z Delay	t <sub>7</sub>				500	ns

**Note 2:** Specifications are guaranteed for the stated global conditions, unless otherwise noted. 100% production tested at  $T_A = +25^{\circ}C$  and  $T_A = +85^{\circ}C$ . Specifications at  $T_A = -40^{\circ}C$  are guaranteed by design.

**Note 3:** For  $V_{CC}$  of 3.6V or lower, connect  $V_{CC}$ ,  $DBP$ , and  $ABP$  together. For higher supply applications, connect only  $V_{CC}$  to the supply rail.

**Note 4:** Applies to RESET (except for reset timeout period of 25μs), fault, autoretry, sequence delays, and watchdog timeout.

# 6-Channel, Flash-Configurable System Manager with Nonvolatile Fault Registers

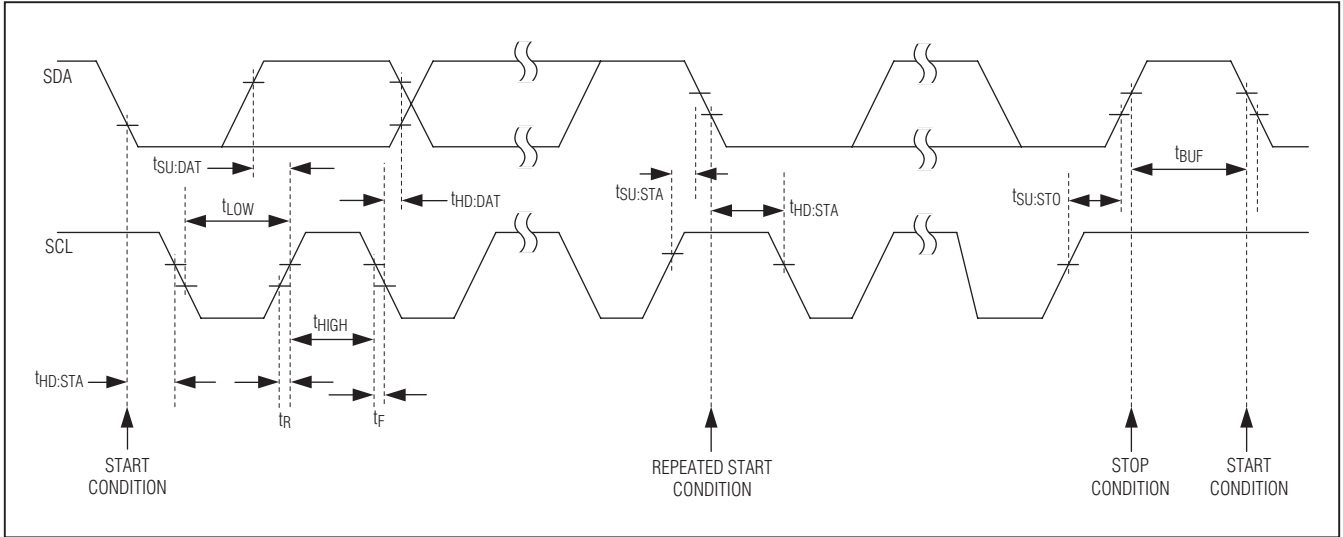

Figure 1. SMBus Timing Diagram

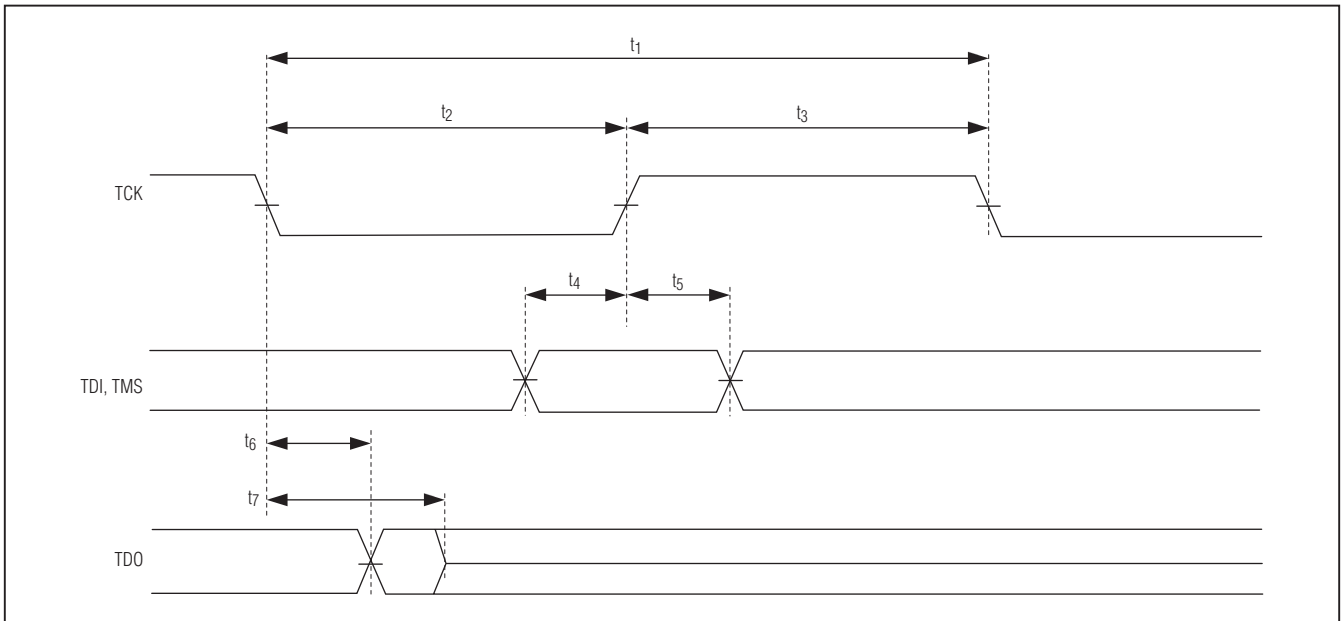
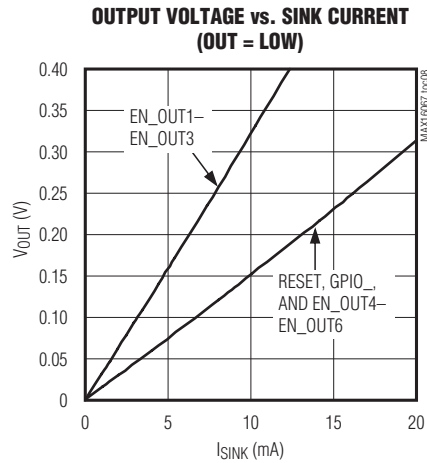
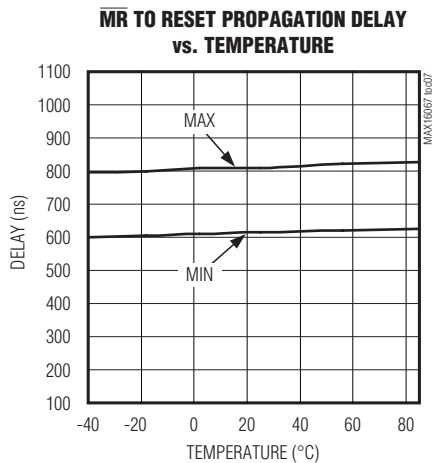
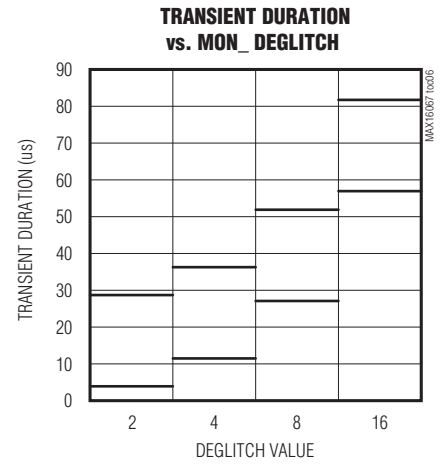
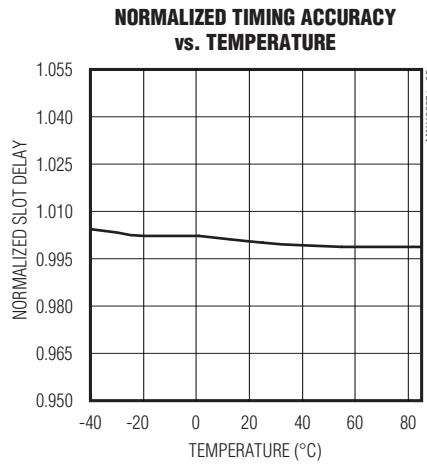
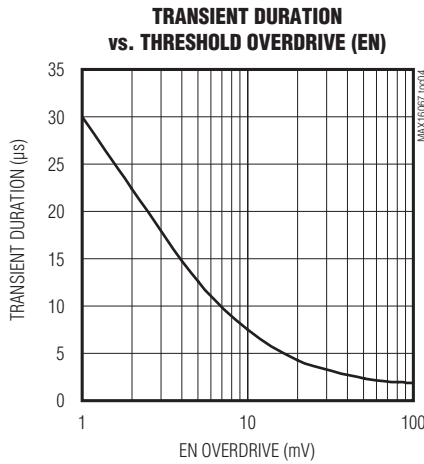
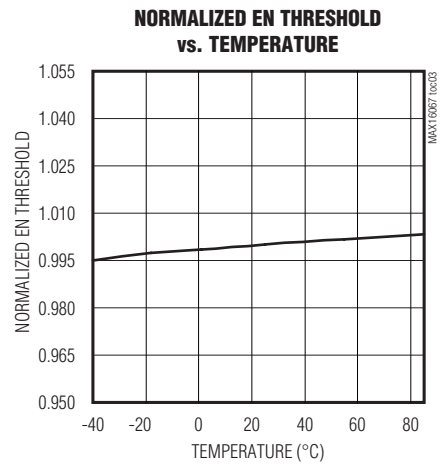
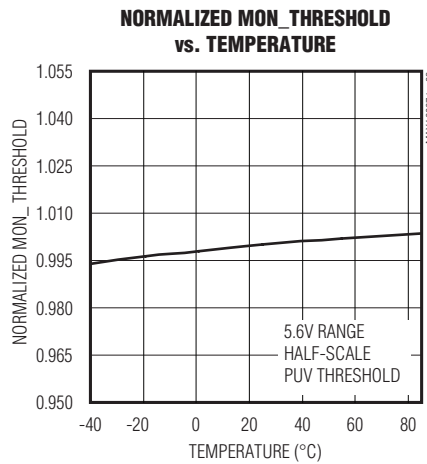
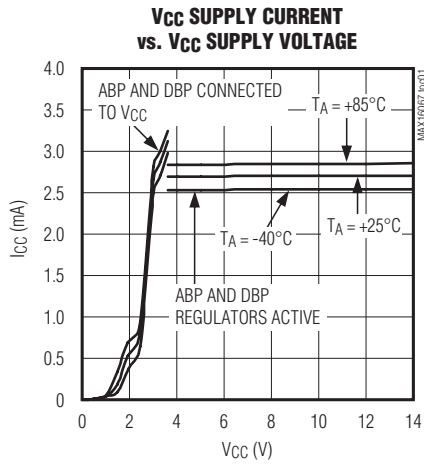

Figure 2. JTAG Timing Diagram

# 6-Channel, Flash-Configurable System Manager with Nonvolatile Fault Registers

## Typical Operating Characteristics

(Typical values are at  $V_{CC} = 3.3V$ ,  $T_A = +25^\circ C$ .)



# 6-Channel, Flash-Configurable System Manager with Nonvolatile Fault Registers

## Typical Operating Characteristics (continued)

(Typical values are at  $V_{CC} = 3.3V$ ,  $T_A = +25^\circ C$ .)

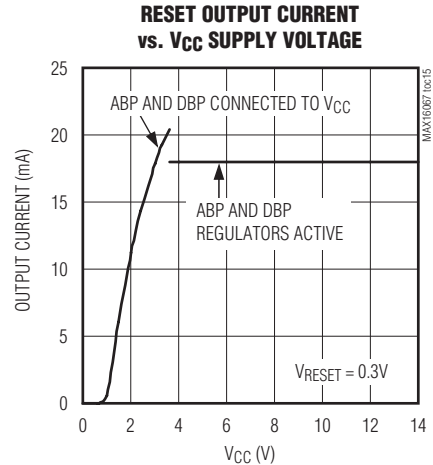
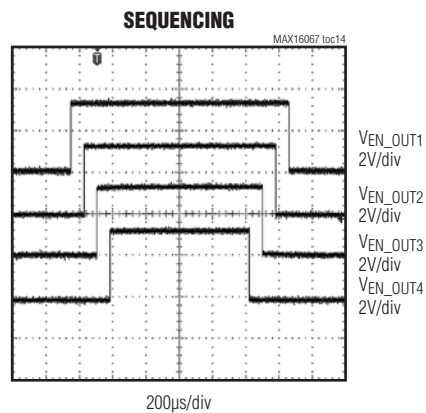
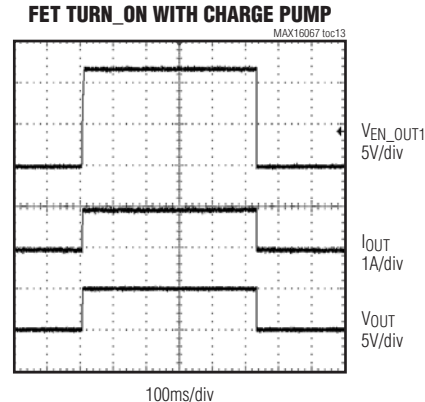
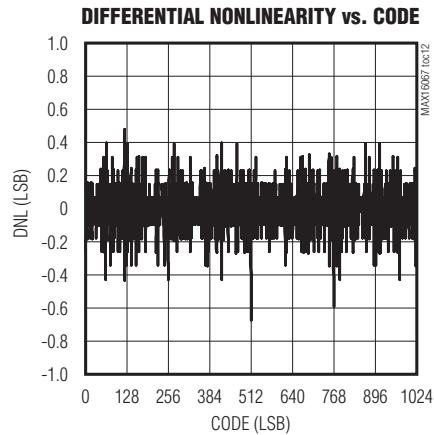
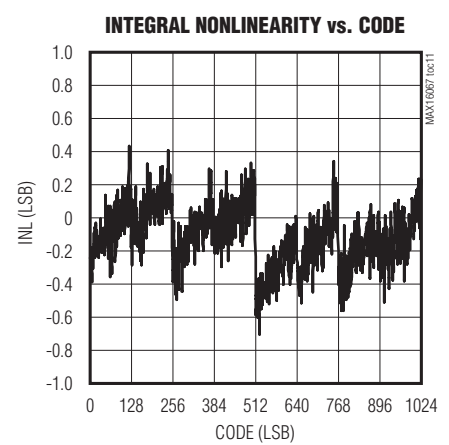
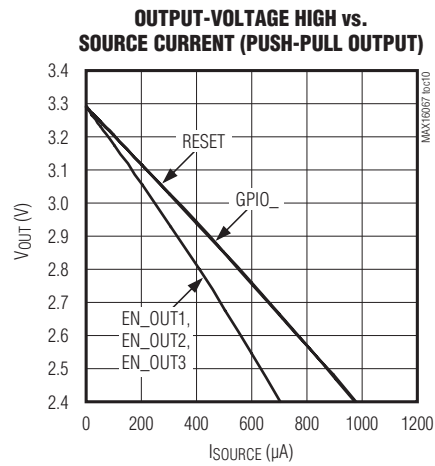
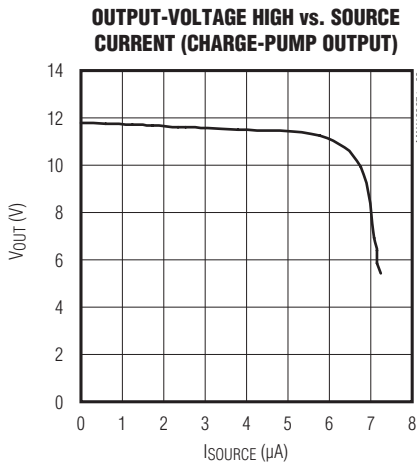

# 6-Channel, Flash-Configurable System Manager with Nonvolatile Fault Registers

## Pin Configuration

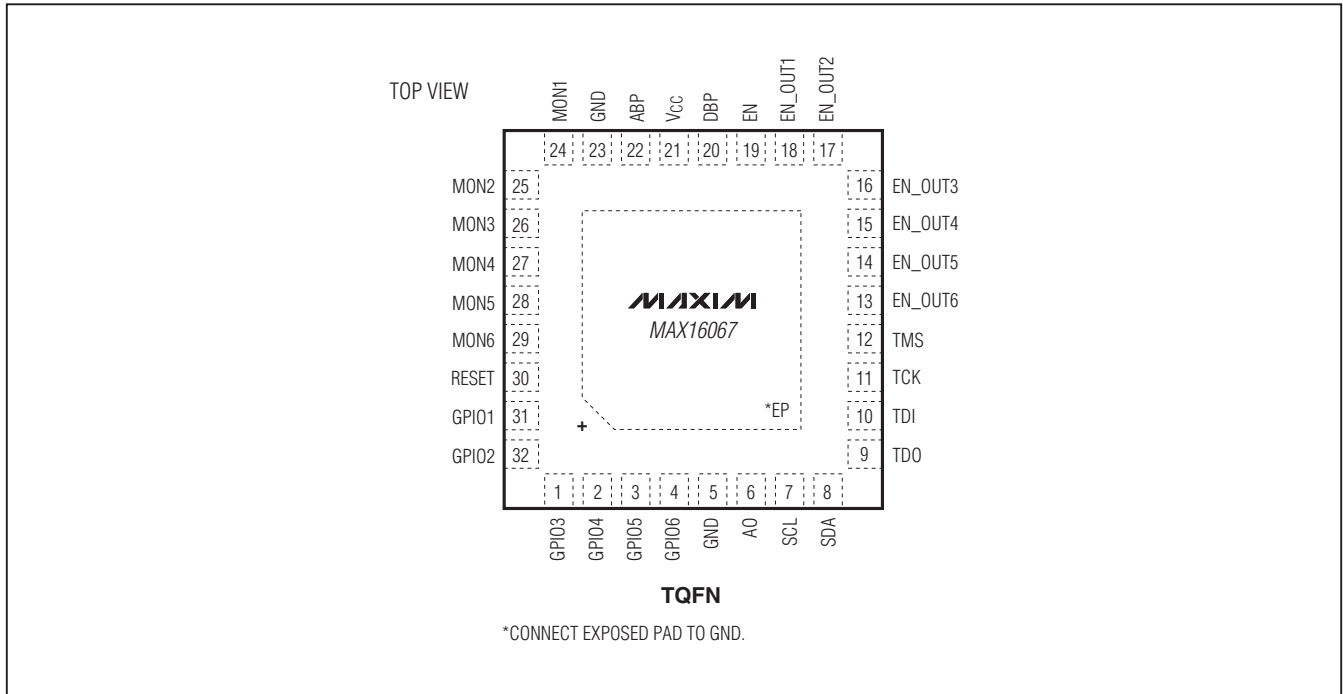

## Pin Description

PIN	NAME	FUNCTION
1–4, 31, 32	GPIO3–GPIO6, GPIO1, GPIO2	General-Purpose Inputs/Outputs. Each GPIO_ can be configured to act as an input, a push-pull output, an open-drain output, or a special function.
5, 23	GND	Ground. Connect all GNDs together.
6	AO	Four-State SMBus Address. Address is sampled upon POR.
7	SCL	SMBus Serial-Clock Input
8	SDA	SMBus Serial-Data Open-Drain Input/Output
9	TDO	JTAG Test Data Output
10	TDI	JTAG Test Data Input
11	TCK	JTAG Test Clock
12	TMS	JTAG Test Mode Select
13–18	EN_OUT6–EN_OUT1	Outputs. Set EN_OUT_ with an active-high/active-low logic and with push-pull or open-drain configuration. EN_OUT_ can be asserted by a combination of MON_ voltages configurable through the flash. EN_OUT1–EN_OUT3 can be configured with a charge-pump output (+12V above GND) that can drive an external n-channel MOSFET. All EN_OUT_ can be configured as GPIOs.
19	EN	Analog Enable Input. All outputs deassert when V <sub>EN</sub> is below the enable threshold.



# 6-Channel, Flash-Configurable System Manager with Nonvolatile Fault Registers

## Pin Description (continued)

PIN	NAME	FUNCTION
20	DBP	Digital Bypass. All push-pull outputs are referenced to DBP. Bypass DBP with a 1μF capacitor to GND.
21	VCC	Power-Supply Input. Bypass VCC to GND with a 10μF ceramic capacitor.
22	ABP	Analog Bypass. Bypass ABP to GND with a 1μF ceramic capacitor.
24–29	MON1–MON6	Monitor Voltage Inputs. Set the monitor voltage range through the configuration registers. Measured values are written to the ADC registers and can be read back through the SMBus or JTAG interface.
30	RESET	Configurable Reset Output
—	EP	Exposed Pad. Internally connected to GND. Connect to ground, but do not use EP as the main ground connection.

## Functional Diagram

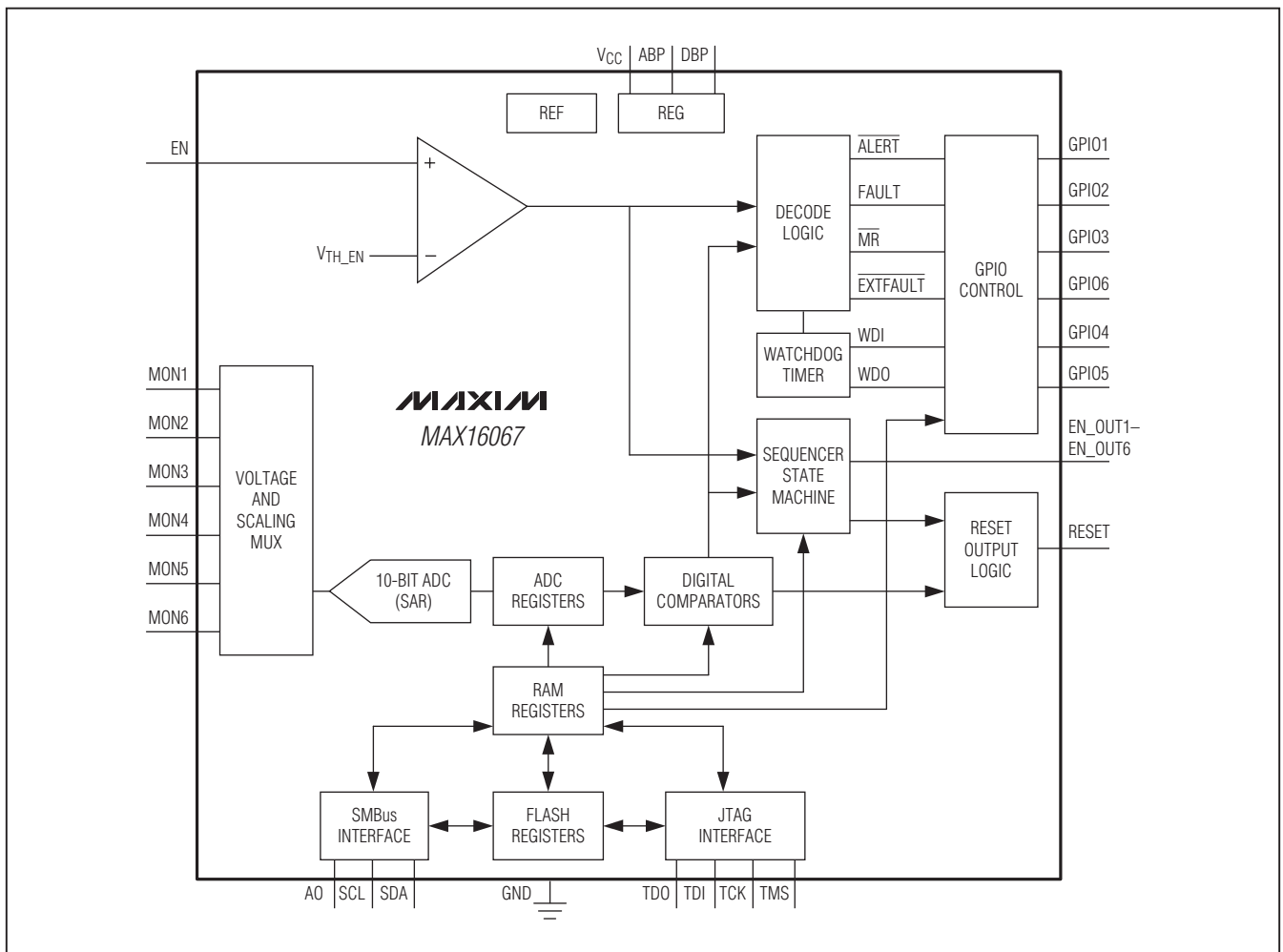

# 6-Channel, Flash-Configurable System Manager with Nonvolatile Fault Registers

## Detailed Description

The MAX16067 manages up to six system power supplies. After boot-up, if EN is high and the software-enable bit is set to '1,' a power-up sequence begins based on the configuration stored in flash and the EN\_OUT\_s are controlled accordingly. When the power-up sequence is successfully completed, the monitoring phase begins. An internal multiplexer cycles through each MON\_ input. At each multiplexer stop, the 10-bit ADC converts the monitored analog voltage to a digital result and stores the result in a register. Each time a conversion cycle (5 $\mu$ s, max) completes, internal logic circuitry compares the conversion results to the overvoltage and undervoltage thresholds stored in memory. When a result violates a programmed threshold, the conversion can be configured to generate a fault. GPIO\_ can be programmed to assert on combinations of faults. Additionally, faults can be configured to shut off the system and trigger the nonvolatile fault logger, which writes all fault information automatically to the flash and write-protects the data to prevent accidental erasure.

The MAX16067 contains both SMBus and JTAG serial interfaces for accessing registers and flash. Use only one interface at any given time. For more information on how to access the internal memory through these interfaces, see the *SMBus-Compatible Serial Interface* and *JTAG Serial Interface* sections. The memory map is divided into three pages with access controlled by special SMBus and JTAG commands.

The factory-default values at POR (power-on reset) for all RAM registers are '0's. POR occurs when VCC reaches the undervoltage-lockout threshold (UVLO) of 2.7V (max). At POR, the device begins a boot-up sequence. During the boot-up sequence, all monitored inputs are masked from initiating faults and flash contents are copied to the respective register locations. During boot-up, the MAX16067 is not accessible through the serial interface. The boot-up sequence takes up to 150 $\mu$ s, after which the device is ready for normal operation. RESET is asserted low up to the boot-up phase after which it assumes its programmed active state. RESET remains active for its programmed timeout period once sequencing is completed and all monitored channels are within their respective thresholds. Up to the boot-up phase, the GPIO\_s and EN\_OUT\_s are high impedance.

## Power

Apply 2.8V to 14V to VCC to power the MAX16067. Bypass VCC to ground with a 10 $\mu$ F capacitor. Two internal voltage regulators, ABP and DBP, supply power to the analog and digital circuitry within the device. For operation at 3.6V or lower, disable the regulators by connecting ABP and DBP to VCC.

ABP is a 3.0V (typ) voltage regulator that powers the internal analog circuitry. Bypass ABP to GND with a 1 $\mu$ F ceramic capacitor installed as close as possible to the device.

DBP is an internal 3.0V (typ) voltage regulator. DBP powers flash and digital circuitry. All push-pull outputs refer to DBP. DBP supplies the input voltage to the internal charge pump when the programmable outputs are configured as charge-pump outputs. Bypass the DBP output to GND with a 1 $\mu$ F ceramic capacitor installed as close as possible to the device.

Do not power external circuitry from ABP or DBP.

## Sequencing

To sequence a system of power supplies safely, the output voltage of a power supply must be good before the next power supply may turn on. Connect EN\_OUT\_ outputs to the enable input of the external power supplies and connect MON\_ inputs to the output of the power supplies for voltage monitoring. More than one MON\_ can be used if the power supply has multiple outputs.

## Sequence Order

The MAX16067 provides a system of ordered slots to sequence multiple power supplies. To determine the sequence order, assign each EN\_OUT\_ to a slot ranging from Slot 1 to Slot 6 (Table 6b). EN\_OUT\_(s) assigned to Slot 1 are turned on first, followed by outputs assigned to Slot 2 through Slot 6. Multiple EN\_OUT\_s assigned to the same slot turn on at the same time.

Each slot includes a built-in configurable sequence delay (registers r77h to r7Dh) ranging from 80 $\mu$ s to 5.079s. During a reverse sequence, slots are turned off in reverse order starting from Slot 6. The MAX16067 can be configured to power down in simultaneous mode or in reverse-sequence mode as set in r75h[0]. Set r75h[0] to '1' for reverse sequence power-down.

See Tables 5 and 6 for the MON\_ and EN\_OUT\_ slot assignment bits, and Tables 2 and 3 for the sequence delays.

During power-up or power-down sequencing, the current sequencer state can be found in r21h[3:0].

## 6-Channel, Flash-Configurable System Manager with Nonvolatile Fault Registers

**Table 1. Current Sequencer Slot**

REGISTER ADDRESS	BIT RANGE	DESCRIPTION
21h	[3:0]	Current-sequencer state 0000 = Slot0 0001 = Slot1 0010 = Slot2 0011 = Slot3 0100 = Slot4 0101 = Slot5 0110 = Slot6 0111 = Power-on mode 1000 = Fault state 1001 to 1111 = Unused
	[7:4]	Reserved

A sequencing delay occurs between each slot and is configured in registers 77h–7Dh as shown in Table 2. Each sequencing delay is stored as an 8-bit value and is calculated as follows:

$$t_{SEQ} = (5 \times 10^{-6}) \times 2^a \times (16 + b)$$

where  $t_{SEQ}$  is in seconds,  $a$  is the decimal value of the 4 MSBs and  $b$  is the decimal value of the 4 LSBs. See Table 3 for example calculations.

### Enable Input (EN)

To initiate sequencing and enable monitoring, the voltage at EN must be above 1.24V (typ) and the software enable bit in r73h[0] must be set to '1.' To power down and disable monitoring, either pull EN below 1.215V (typ) or set the software enable bit to '0.' See Table 4 for the software enable bit configurations. Connect EN to ABP if not used.

If a fault condition occurs during the power-up cycle, the EN\_OUT\_ outputs are powered down immediately, regardless of the state of EN. In the monitoring state, if EN falls below the threshold, the sequencing state machine begins the power-down sequence. If EN rises above the threshold during the power-down sequence, the sequence state machine continues the power-down sequence until all the channels are powered off and then the device immediately begins the power-up sequence. When in the monitoring state, and when EN falls below the undervoltage threshold, a register bit, ENRESET (r20h[2]), is set to a '1.' This register bit latches and must be cleared through software. This bit indicates if RESET is asserted low due to EN going under the threshold. The POR state of ENRESET is '0'. The bit is only set on a falling edge of the EN comparator output or the software enable bit. If operating in latch-on fault mode, toggle EN or toggle the software enable bit to clear the latch condition and restart the device once the fault condition has been removed.

**Table 2. Slot Delay Register**

REGISTER ADDRESS	FLASH ADDRESS	BIT RANGE	DESCRIPTION
77h	277h	[7:0]	Sequence slot 0 to slot 1 delay
78h	278h	[7:0]	Sequence slot 1 to slot 2 delay
79h	279h	[7:0]	Sequence slot 2 to slot 3 delay
7Ah	27Ah	[7:0]	Sequence slot 3 to slot 4 delay
7Bh	27Bh	[7:0]	Sequence slot 4 to slot 5 delay
7Ch	27Ch	[7:0]	Sequence slot 5 to slot 6 delay
7Dh	27Dh	[7:0]	Sequence slot 6 to power-on state delay

## 6-Channel, Flash-Configurable System Manager with Nonvolatile Fault Registers

**Table 3. Power-Up/Power-Down Slot Delays**

Code	Value
0000 0000	$t_{SEQ} = (5 \times 10^{-6}) \times 2^a \times (16 + b) = (5 \times 10^{-6}) \times 2^0 \times (16 + 0) = 80\mu\text{s}$
⋮	⋮
1111 1111	$t_{SEQ} = (5 \times 10^{-6}) \times 2^a \times (16 + b) = (5 \times 10^{-6}) \times 2^{15} \times (16 + 15) = 5.079\text{s}$

**Table 4. Software Enable Configurations**

REGISTER ADDRESS	FLASH ADDRESS	BIT RANGE	DESCRIPTION
73h	273h	[0]	Software enable 1 = Sequencing enabled 0 = Power-down
		[1]	Reserved
		[2]	1 = Margin mode enabled
		[3]	Reserved
		[4]	Independent watchdog mode enable 1 = Watchdog timer is independent of sequencer 0 = Watchdog timer boots after sequence completes

### Monitoring Inputs While Sequencing

An enabled MON\_ input can be assigned to a slot ranging from Slot 1 to Slot 6. EN\_OUT\_s are always asserted at the beginning of a slot. The supply voltages connected to the MON\_ inputs must exceed the undervoltage threshold before the programmed fault timeout period expires, otherwise, a fault condition occurs. Once a MON\_ input crosses the undervoltage threshold, the monitoring for overvoltage begins. The undervoltage and overvoltage threshold checking cannot be disabled during power-up and power-down. See Tables 5 and 6 for the MON\_ slot assignment bits. The programmed sequence delay is then counted before moving to the next slot.

Slot 0 does not monitor any MON\_ input and does not control any EN\_OUT\_. Slot 0 waits for the software enable bit r73h[0] to be a logic-high and for the voltage on EN to rise above 1.24V (typ) before initiating the power-up sequence and counting its own sequence delay.

Any MON\_ input that suffers a fault during power-up sequencing causes all the EN\_OUT\_s to turn off and the sequencer to shut down regardless of the state of the critical fault enables (see the *Faults* section). If a MON\_ input is less critical to system operation, it can be configured as “monitoring only” (see Table 6a) for sequencing. Monitoring for MON\_ inputs assigned as “monitoring only” begins after sequencing is complete, and can trigger a critical fault only if specifically configured to do so using the critical fault enables.

# 6-Channel, Flash-Configurable System Manager with Nonvolatile Fault Registers

MAX16067

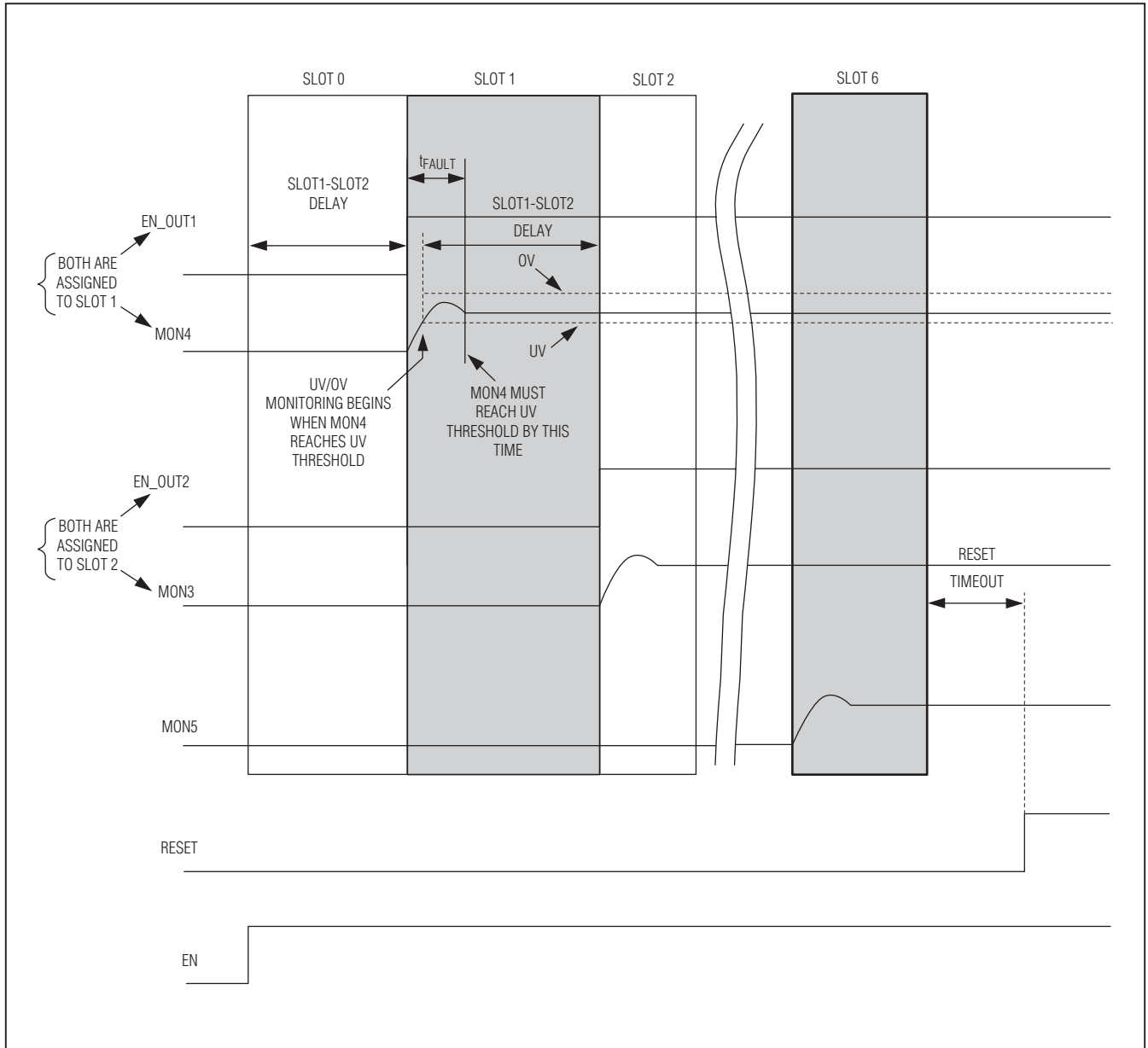

Figure 3. Delay and Reset Timing

## 6-Channel, Flash-Configurable System Manager with Nonvolatile Fault Registers

Table 5. MON\_ and EN\_OUT\_ Assignment Registers

REGISTER ADDRESS	FLASH ADDRESS	BIT RANGE	DESCRIPTION
7Eh	27Eh	[2:0]	MON1
		[3]	Not used
		[6:4]	MON2
		[7]	Not used
7Fh	27Fh	[2:0]	MON3
		[3]	Not used
		[6:4]	MON4
		[7]	Not used
80h	280h	[2:0]	MON5
		[3]	Not used
		[6:4]	MON6
		[7]	Not used
81h–83h	281h–283h	—	Not used
84h	284h	[3:0]	EN_OUT1
		[7:4]	EN_OUT2
85h	285h	[3:0]	EN_OUT3
		[7:4]	EN_OUT4
86h	286h	[3:0]	EN_OUT5
		[7:4]	EN_OUT6

Table 6a. MON\_ Slot Assignment Codes

SLOT ASSIGNMENT	
CODE	MON_ DESCRIPTION
000	Not assigned
001	Slot 1
010	Slot 2
011	Slot 3
100	Slot 4
101	Slot 5
110	Slot 6
111	Monitoring-only state

Table 6b. EN\_OUT\_ Slot Assignment Codes

SLOT ASSIGNMENT	
CODE	EN_OUT_ DESCRIPTION
0000	Not assigned
0001	Slot 1
0010	Slot 2
0011	Slot 3
0100	Slot 4
0101	Slot 5
0110	Slot 6
1101	General-purpose input
1110	General-purpose output
—	All other unspecified codes are not assigned.

## 6-Channel, Flash-Configurable System Manager with Nonvolatile Fault Registers

### Power-Up

On power-up, when EN is high and the software enable bit is '1', the MAX16067 begins sequencing with Slot 0. After the sequencing delay for Slot 0 expires, the sequencer advances to Slot 1, and all EN\_OUT\_s assigned to the slot assert. All MON\_ inputs assigned to Slot 1 are monitored and when the voltage rises above the undervoltage (UV) fault threshold, the sequence delay counter is started. When the sequence delay expires, the MAX16067 proceeds to the next slot.

When the tFAULT counter expires before all MON\_ inputs assigned to the slot are above the fault UV threshold, a fault asserts. EN\_OUT\_ outputs are disabled and the MAX16067 returns to the fault state. Register r75h[4:1] sets the tFAULT delay. See Table 7 for details.

After the voltages on all MON\_ inputs assigned to the last slot exceed the UV fault threshold and the slot delay expires, the MAX16067 starts the reset timeout counter. After the reset timeout, RESET deasserts. See Table 22 for more information on setting the reset timeout.

### Power-Down

Power-down starts when EN is pulled low or the software enable bit is set to '0.' Power down EN\_OUT\_s simultaneously or in reverse sequence mode by setting the reverse sequence bit (r75h[0]) appropriately. Set r75h[0] to '1' to power down in reverse sequence.

### Reverse Sequence Mode

When the MAX16067 is fully powered up and EN is pulled low or the software enable bit is set to '0', the EN\_OUT\_s assigned to Slot 6 deassert, the MAX16067 waits for the Slot 6 sequence delay and then proceeds to the previous slot (Slot 5), and so on until the EN\_OUT\_s assigned to Slot 1 turn off. When simultaneous power-down is selected (r75h[0] is set to '0'), all EN\_OUT\_s turn off at the same time.

### Voltage Monitoring

The MAX16067 features an internal 10-bit ADC that monitors the MON\_ voltage inputs. An internal multiplexer cycles through each of the enabled inputs, taking less than 24μs for a complete monitoring cycle. Each acquisition takes approximately 4μs. At each multiplexer stop, the 10-bit ADC converts the analog input to a digital result and stores the result in a register. ADC conversion results are stored in registers r00h–r0Bh (see Table 9). Use the SMBus or JTAG serial interface to read ADC conversion results.

The MAX16067 provides six inputs, MON1–MON6, for voltage monitoring. Each input-voltage range

Table 7. tFAULT Delay Settings

r75h[4:1]	FAULT DELAY
0000	120μs
0001	150μs
0010	250μs
0011	380μs
0100	600μs
0101	1ms
0110	1.5ms
0111	2.5ms
1000	4ms
1001	6ms
1010	10ms
1011	15ms
1100	25ms
1101	40ms
1110	60ms
1111	100ms

is programmable in registers r43h–r44h (see Table 8). When MON\_ configuration registers are set to '11,' MON\_ voltages are not monitored and the multiplexer does not stop at these inputs, decreasing the total cycle time. These inputs cannot be configured to trigger fault conditions.

The two programmable thresholds for each monitored voltage include an overvoltage and an undervoltage threshold. See the *Faults* section for more information on setting overvoltage and undervoltage thresholds. All voltage thresholds are 8 bits wide. The 8 MSBs of the 10-bit ADC conversion result are compared to these overvoltage and undervoltage thresholds.

For any undervoltage or overvoltage condition to be monitored and any faults detected, the MON\_ input must be assigned to a sequence order or set to monitoring mode as described in the *Sequencing* section. Inputs that are not enabled are not converted by the ADC; they contain the last value acquired before that channel was disabled. The ADC conversion result registers are reset to 00h at boot-up. These registers are not reset when a reboot command is executed.

To temporarily disable voltage monitoring during voltage margining conditions, set r73h[2] to '1' to enable margining mode functionality. Faults, except for faults triggered by EXTFAULT pulled low externally, are not recorded when the device is in margining mode but the ADC continues to run and conversion results continue to be available. Set r73h[2] back to '0' for normal functionality.

## 6-Channel, Flash-Configurable System Manager with Nonvolatile Fault Registers

Table 8. ADC Configuration Registers

REGISTER ADDRESS	FLASH ADDRESS	BIT RANGE	DESCRIPTION
43h	243h	[1:0]	MON1 full-scale range 00 = 5.6V 01 = 2.8V 10 = 1.4V 11 = Channel not converted
		[3:2]	MON2 full-scale range 00 = 5.6V 01 = 2.8V 10 = 1.4V 11 = Channel not converted
		[5:4]	MON3 full-scale range 00 = 5.6V 01 = 2.8V 10 = 1.4V 11 = Channel not converted
		[7:6]	MON4 full-scale range 00 = 5.6V 01 = 2.8V 10 = 1.4V 11 = Channel not converted
44h	244h	[1:0]	MON5 full-scale range 00 = 5.6V 01 = 2.8V 10 = 1.4V 11 = Channel not converted
		[3:2]	MON6 full-scale range 00 = 5.6V 01 = 2.8V 10 = 1.4V 11 = Channel not converted
		[7:4]	Not used

Table 9. ADC Conversion Results (Read Only)

REGISTER ADDRESS	BIT RANGE	DESCRIPTION
00h	[7:0]	MON1 result (MSB)
01h	[7:6]	MON1 result (LSB)
02h	[7:0]	MON2 result (MSB)
03h	[7:6]	MON2 result (LSB)
04h	[7:0]	MON3 result (MSB)
05h	[7:6]	MON3 result (LSB)
06h	[7:0]	MON4 result (MSB)
07h	[7:6]	MON4 result (LSB)
08h	[7:0]	MON5 result (MSB)
09h	[7:6]	MON5 result (LSB)
0Ah	[7:0]	MON6 result (MSB)
0Bh	[7:6]	MON6 result (LSB)



## 6-Channel, Flash-Configurable System Manager with Nonvolatile Fault Registers

### General-Purpose Inputs/Outputs

GPIO1–GPIO6 are programmable general-purpose inputs/outputs. GPIO1–GPIO6 are configurable as a manual reset input, a watchdog timer input and output, logic inputs/outputs, and fault-dependent outputs. When programmed as outputs, GPIOs are open-drain or push-pull. See Tables 10 and 11 for more detailed information on configuring GPIO1–GPIO6.

When GPIO1–GPIO6 are configured as general-purpose inputs/outputs, read values from the GPIO ports through r1Eh and write values to GPIOs through r3Eh. Note that r3Eh has a corresponding flash register, which programs the default state of a general purpose output. See Table 12 for more information on reading and writing to the GPIO.

**Table 10. GPIO\_ Configuration Registers**

REGISTER ADDRESS	FLASH ADDRESS	BIT RANGE	DESCRIPTION
3Fh	23Fh	[1:0]	GPIO1 configuration
		[3:2]	GPIO2 configuration
		[5:4]	GPIO3 configuration
		[7:6]	GPIO4 configuration
40h	240h	[1:0]	GPIO5 configuration
		[3:2]	GPIO6 configuration
		[4]	ARAEN bit
		[7:5]	Not used

**Table 11. GPIO\_ Function Configuration Bits**

	GPIO1	GPIO2	GPIO3	GPIO4	GPIO5	GPIO6
00	Logic input	Logic input	Logic input	Logic input	Logic input	Logic input
01	Logic output (push-pull)	Logic output (push-pull)	Logic output (push-pull)	Logic output (push-pull)	Logic output (push-pull)	Logic output (push-pull)
10	Logic output (open drain)	Logic output (open drain)	Logic output (open drain)	Logic output (open drain)	Logic output (open drain)	Logic output (open drain)
11	$\overline{\text{ALERT}}$ (open drain)	FAULT (open drain)	$\overline{\text{MR}}$ input	WDI	$\overline{\text{WDO}}$ (open drain)	$\overline{\text{EXTFAULT}}$ (open drain)

**Table 12. GPIO\_ State Registers**

REGISTER ADDRESS	FLASH ADDRESS	BIT RANGE	DESCRIPTION
1Eh	—	[0]	GPIO1 input state
		[1]	GPIO2 input state
		[2]	GPIO3 input state
		[3]	GPIO4 input state
		[4]	GPIO5 input state
		[5]	GPIO6 input state
		[7:6]	Not used
3Eh	23Eh	[0]	GPIO1 output state
		[1]	GPIO2 output state
		[2]	GPIO3 output state
		[3]	GPIO4 output state
		[4]	GPIO5 output state
		[5]	GPIO6 output state
		[7:6]	Not used

## 6-Channel, Flash-Configurable System Manager with Nonvolatile Fault Registers

### ALERT

GPIO1 is configurable as the SMBus alert signal, ALERT. ALERT asserts when any fault condition occurs. When the SMBus host sends the ARA (Alert Response Address), the MAX16067 responds with its slave address and deasserts ALERT. ALERT is an open-drain output.

Set the ARAEN bit in r40h[4] to '1' to disable the ARA feature. Under these conditions, the device does not respond to an ARA on the SMBus line.

### FAULT

GPIO2 is configurable as a dedicated fault output, FAULT. FAULT asserts when an overvoltage or undervoltage condition occurs on the selected inputs. FAULT dependencies are set using registers r36h and r37h (see Table 13). When FAULT depends on more than one MON\_, the fault output asserts when one or more MON\_ exceeds a programmed threshold voltage. FAULT acts independently of the critical fault system, described in the *Critical Faults* section. Use r37h[7] to set the polarity of FAULT.

### Manual Reset (MR)

GPIO3 is configurable to act as an active-low manual reset input, MR. Drive MR low to assert RESET. RESET remains asserted for the selected reset timeout period after MR transitions from low to high. When connecting MR to a push-button, use a pullup resistor. See the *Reset Output* section for more information on selecting a reset timeout period.

### Watchdog Input (WDI) and Output (WDO)

GPIO4 and GPIO5 are configurable as the watchdog timer input (WDI) and output, WDO, respectively. See Table 23 for configuration details. WDO is an open-drain, active-low output. See the *Watchdog Timer* section for more information about the operation of the watchdog timer.

### External Fault (EXTFAULT)

GPIO6 is configurable as the external fault input/output, EXTFAULT. EXTFAULT asserts if any monitored voltage exceeds an overvoltage or undervoltage threshold. EXTFAULT also asserts if a power-up or power-down sequencing fault occurs. This signal can be used to cascade multiple MAX16067s.

Pull EXTFAULT low externally to force the sequencer to enter a fault state. Under these conditions, all outputs deassert.

Two configuration bits determine the behavior of the MAX16067 when EXTFAULT is pulled low by an external device. Register bit r72h[5], if set to a '1', causes the sequencer state machine to enter the fault state, deasserting all the outputs when EXTFAULT is pulled low. When this happens, the flag bit r1Ch[6] is set to indicate the cause of the fault. If register bit r6Dh[2] is set in addition to r72h[5], EXTFAULT going low triggers a nonvolatile fault log operation.

**Table 13. FAULT Dependencies**

REGISTER ADDRESS	FLASH ADDRESS	BIT RANGE	DESCRIPTION
36h	236h	[0]	FAULT depends on MON1 undervoltage threshold
		[1]	FAULT depends on MON2 undervoltage threshold
		[2]	FAULT depends on MON3 undervoltage threshold
		[3]	FAULT depends on MON4 undervoltage threshold
		[4]	FAULT depends on MON5 undervoltage threshold
		[5]	FAULT depends on MON6 undervoltage threshold
		[7:6]	Not used
37h	237h	[0]	FAULT depends on MON1 overvoltage threshold
		[1]	FAULT depends on MON2 overvoltage threshold
		[2]	FAULT depends on MON3 overvoltage threshold
		[3]	FAULT depends on MON4 overvoltage threshold
		[4]	FAULT depends on MON5 overvoltage threshold
		[5]	FAULT depends on MON6 overvoltage threshold
		[6]	Not used
		[7]	0 = FAULT is an active-low digital output 1 = FAULT is an active-high digital output

## 6-Channel, Flash-Configurable System Manager with Nonvolatile Fault Registers

### Faults

The MAX16067 monitors the input (MON\_) channels and compares the results with an overvoltage threshold and an undervoltage threshold. Based on these conditions, the MAX16067 asserts various fault outputs and save specific information about the channel conditions and voltages into the nonvolatile flash. Once a critical fault event occurs, the failing channel condition, ADC conversions at the time of the fault, or both can be saved by configuring the event logger. The event logger records a single failure in the internal flash and sets a lock bit which protects the stored fault data from accidental erasure on a subsequent power-up.

The MAX16067 is capable of measuring overvoltage and undervoltage fault events. Fault conditions are detected at the end of each ADC conversion. An overvoltage event occurs when the voltage at a monitored input exceeds the overvoltage threshold for that input. An undervoltage event occurs when the voltage at a monitored input falls below the undervoltage threshold. Fault thresholds are set in registers r49h–r59h as shown in Table 14. Disabled inputs are not monitored for fault conditions and are skipped over by the input multiplexer. Only the upper 8 bits of a conversion result are compared with the programmed fault thresholds.

**Table 14. Fault Threshold Registers**

REGISTER ADDRESS	FLASH ADDRESS	BIT RANGE	DESCRIPTION
48h	248h	[7:0]	Not used
49h	249h	[7:0]	MON1 overvoltage threshold
4Ah	24Ah	[7:0]	MON1 undervoltage threshold
4Bh	24Bh	[7:0]	Not used
4Ch	24Ch	[7:0]	MON2 overvoltage threshold
4Dh	24Dh	[7:0]	MON2 undervoltage threshold
4Eh	24Eh	[7:0]	Not used
4Fh	24Fh	[7:0]	MON3 overvoltage threshold
50h	250h	[7:0]	MON3 undervoltage threshold
51h	251h	[7:0]	Not used
52h	252h	[7:0]	MON4 overvoltage threshold
53h	253h	[7:0]	MON4 undervoltage threshold
54h	254h	[7:0]	Not used
55h	255h	[7:0]	MON5 overvoltage threshold
56h	256h	[7:0]	MON5 undervoltage threshold
57h	257h	[7:0]	Not used
58h	258h	[7:0]	MON6 overvoltage threshold
59h	259h	[7:0]	MON6 undervoltage threshold

## 6-Channel, Flash-Configurable System Manager with Nonvolatile Fault Registers

### Deglitch

Fault conditions are detected at the end of each conversion. When the voltage on an input falls outside a monitored threshold for one acquisition, the input multiplexer remains on that channel and performs several successive conversions. To trigger a fault, the input must stay outside the threshold for a certain number of acquisitions as determined by the deglitch setting in r74h[6:5] (see Table 15).

### Fault Flags

Fault flags indicate the fault status of a particular input. The fault flag of any monitored input in the device can be read at any time from registers r1Bh and r1Ch, as shown

in Table 16. Clear a fault flag by writing a '1' to the appropriate bit in the flag register. Unlike the fault signals sent to the fault outputs, these bits are masked by the critical fault enable bits (see Table 17). The fault flag is only set when the matching enable bit in the critical fault enable register is also set.

If GPIO6 is configured as the  $\overline{\text{EXTFAULT}}$  input/output and  $\overline{\text{EXTFAULT}}$  is pulled low by an external circuit, bit r1Ch[6] is set.

The SMB Alert ( $\overline{\text{ALERT}}$ ) bit is set if the MAX16067 has asserted the SMBus Alert output. Clear by writing a '1'. See the *SMBALERT* ( $\overline{\text{ALERT}}$ ) section for more details.

**Table 15. Deglitch Configuration**

REGISTER ADDRESS	FLASH ADDRESS	BIT RANGE	DESCRIPTION
74h	274h	[6:5]	Voltage comparator deglitch configuration 00 = 2 cycles 01 = 4 cycles 10 = 8 cycles 11 = 16 cycles

**Table 16. Fault Flags**

REGISTER ADDRESS	BIT RANGE	DESCRIPTION
1Bh	[0]	MON1 undervoltage threshold
	[1]	MON2 undervoltage threshold
	[2]	MON3 undervoltage threshold
	[3]	MON4 undervoltage threshold
	[4]	MON5 undervoltage threshold
	[5]	MON6 undervoltage threshold
	[7:6]	Reserved
1Ch	[0]	MON1 overvoltage threshold
	[1]	MON2 overvoltage threshold
	[2]	MON3 overvoltage threshold
	[3]	MON4 overvoltage threshold
	[4]	MON5 overvoltage threshold
	[5]	MON6 overvoltage threshold
	[6]	External fault ( $\overline{\text{EXTFAULT}}$ )
	[7]	SMB alert

## 6-Channel, Flash-Configurable System Manager with Nonvolatile Fault Registers

### Critical Faults

During normal operation, a fault condition can be configured to shut down all the EN\_OUT\_s and store fault information in the flash memory by setting the appropriate critical fault enable bits. During power-up and power-down, all sequenced MON inputs are considered critical. Faults during power-up and power-down always cause the EN\_OUT\_s to turn off and can store fault information in the flash memory, depending on the contents of r6Dh[1:0]. Set the appropriate critical fault enable bits in registers r6Eh–r72h (see Table 17) for a fault condition to trigger a critical fault.

Logged fault information is stored in flash registers r200h–r208h (see Table 18). After fault information is

logged, the flash is locked and must be unlocked to enable a new fault log to be stored. Write a '0' to r8Ch[1] to unlock the configuration flash. Fault information can be configured to store ADC conversion results and/or fault flags in registers. Select the critical fault configuration in r6Dh[1:0]. Set r6Dh[1:0] to '11' to turn off the fault logger. All stored ADC results are 8 bits wide (MSBs of the conversion).

### Power-Up/Power-Down Faults

All EN\_OUT\_s deassert when an overvoltage or undervoltage fault is detected during power-up/power-down and the MAX16067 enters to the fault state. Fault information can be stored to flash depending on r6D[1:0] (see Table 17).

**Table 17. Critical Fault Configuration**

REGISTER ADDRESS	FLASH ADDRESS	BIT RANGE	DESCRIPTION
6Dh	26Dh	[1:0]	Fault Information to Log 00 = Save failed line flags and ADC values in flash 01 = Save only failed line flags in flash 10 = Save only ADC values in flash 11 = Do not save anything
		[2]	1 = Fault log triggered when $\overline{\text{EXTFAULT}}$ is pulled low externally
		[7:3]	Not used
6Eh	26Eh	[0]	1 = Fault log triggered when MON1 is below its undervoltage threshold
		[1]	1 = Fault log triggered when MON2 is below its undervoltage threshold
		[2]	1 = Fault log triggered when MON3 is below its undervoltage threshold
		[3]	1 = Fault log triggered when MON4 is below its undervoltage threshold
		[4]	1 = Fault log triggered when MON5 is below its undervoltage threshold
		[5]	1 = Fault log triggered when MON6 is below its undervoltage threshold
		[7:6]	Not used
6Fh	26Fh	[3:0]	Not used
		[4]	1 = Fault log triggered when MON1 is above its overvoltage threshold
		[5]	1 = Fault log triggered when MON2 is above its overvoltage threshold
		[6]	1 = Fault log triggered when MON3 is above its overvoltage threshold
		[7]	1 = Fault log triggered when MON4 is above its overvoltage threshold
70h	270h	[0]	1 = Fault log triggered when MON5 is above its overvoltage threshold
		[1]	1 = Fault log triggered when MON6 is above its overvoltage threshold
		[7:2]	Not used
71h	271h	[7:0]	Not used
72h	272h	[4:0]	Not used
		[5]	1 = $\overline{\text{EXTFAULT}}$ pulled low externally causes sequencer to enter fault state, turning off all EN_OUT_s 0 = $\overline{\text{EXTFAULT}}$ pulled low externally does not cause sequencer to enter fault state
		[7:6]	Not used

## 6-Channel, Flash-Configurable System Manager with Nonvolatile Fault Registers

Table 18. Nonvolatile Fault Log Registers

FLASH ADDRESS	BIT RANGE	DESCRIPTION
200h	[3:0]	Sequencer state where the fault has happened (see Table 1 for state codes). Fault has happened during power-up if bit [3] = 0 and during power-down if [3] = 1. Bits [2:0] indicate the slot number.
	[7:4]	Not used
201h	[0]	Fault log triggered on MON1 falling below its undervoltage threshold
	[1]	Fault log triggered on MON2 falling below its undervoltage threshold
	[2]	Fault log triggered on MON3 falling below its undervoltage threshold
	[3]	Fault log triggered on MON4 falling below its undervoltage threshold
	[4]	Fault log triggered on MON5 falling below its undervoltage threshold
	[5]	Fault log triggered on MON6 falling below its undervoltage threshold
202h	[7:6]	Not used
	[0]	Fault log triggered on MON1 exceeding its overvoltage threshold
	[1]	Fault log triggered on MON2 exceeding its overvoltage threshold
	[2]	Fault log triggered on MON3 exceeding its overvoltage threshold
	[3]	Fault log triggered on MON4 exceeding its overvoltage threshold
	[4]	Fault log triggered on MON5 exceeding its overvoltage threshold
	[5]	Fault log triggered on MON6 exceeding its overvoltage threshold
	[6]	Fault log triggered on $\overline{\text{EXTFAULT}}$
[7]	Not used	
203h	[7:0]	MON1 ADC output (8 MSBs)
204h	[7:0]	MON2 ADC output (8 MSBs)
205h	[7:0]	MON3 ADC output (8 MSBs)
206h	[7:0]	MON4 ADC output (8 MSBs)
207h	[7:0]	MON5 ADC output (8 MSBs)
208h	[7:0]	MON6 ADC output (8 MSBs)

### Autoretry/Latch Mode

The MAX16067 can be configured for one of two fault management methods: autoretry or latch-on-fault. Set r74h[4:3] to '00' to select the latch-on-fault mode. In this configuration, EN\_OUT\_s deassert after a critical fault event. The device does not reinitiate the power-up sequence until EN is toggled or the software enable bit is toggled. See the *Enable Input (EN)* section for more information on setting the software enable bit.

Set r74h[4:3] to a value other than '00' to select autoretry mode (see Table 19). In this configuration, the device shuts down after a critical fault event then restarts following a configurable delay. Use r74h[2:0] to select an

autoretry delay from 20ms to 1.6s. See Table 19 for more information on setting the autoretry delay.

When fault information is stored in flash (see the *Critical Faults* section) and autoretry mode is selected, set an autoretry delay greater than the time required for the storing operation. When fault information is stored in flash and latch-on-fault mode is chosen, toggle EN or reset the software enable bit only after the completion of the storing operation. When saving information about the failed lines only, ensure a delay of at least 12ms before the restart procedure. Otherwise, ensure a minimum 153ms timeout, to ensure that ADC conversions are completed and values are stored correctly in flash.

## 6-Channel, Flash-Configurable System Manager with Nonvolatile Fault Registers

Table 19. Autoretry Configuration

REGISTER ADDRESS	FLASH ADDRESS	BIT RANGE	DESCRIPTION
74h	274h	[2:0]	Retry Delay 000 = 20ms 001 = 40ms 010 = 80ms 011 = 150ms 100 = 280ms 101 = 540ms 110 = 1s 111 = 2s
		[4:3]	Autoretry/Latch Mode 00 = Latch 01 = Reserved 10 = Reserved 11 = Always retry

### Programmable Outputs (EN\_OUT1-EN\_OUT6)

The MAX16067 includes six programmable outputs. These outputs are capable of connecting to either the enable (EN) inputs of a DC-DC or LDO power supply, or to drive the gate of an n-channel MOSFET in charge-pump mode. Selectable output configurations include: active-low or active-high, open-drain or push-pull. EN\_OUT1-EN\_OUT3 can act as charge-pump outputs, EN\_OUT1-EN\_OUT6 can be configured as general-purpose inputs or general-purpose outputs. Use the registers r30h-r33h to configure outputs. See Table 20 for detailed information on configuring EN\_OUT1-EN\_OUT6.

**In charge-pump configuration:** EN\_OUT1, EN\_OUT2, and EN\_OUT3 act as high-voltage charge-pump outputs to drive up to three external n-channel MOSFETs. During sequencing, an EN\_OUT\_ output is configured as a charge-pump output 11V above GND. See the *Sequencing* section for more detailed information on power-supply sequencing.

**In open-drain output configuration:** Connect an external pullup resistor from the output to an external voltage up to 5.5V (EN\_OUT4, EN\_OUT5, EN\_OUT6) or 14V (EN\_OUT1, EN\_OUT2, EN\_OUT3) when configured as an open-drain output. Choose the pullup resistor depending on the number of devices connected to the open-drain output and the allowable current consumption. The open-drain output configuration allows wired-OR connection.

**In push-pull configuration:** The MAX16067's programmable outputs are referenced to V<sub>DBP</sub>.

## 6-Channel, Flash-Configurable System Manager with Nonvolatile Fault Registers

Table 20. EN\_OUT1–EN\_OUT6 Configuration

REGISTER ADDRESS	FLASH ADDRESS	BIT RANGE	DESCRIPTION
30h	230h	[1:0]	EN_OUT1 Configuration 00 = Active-low, open drain 01 = Active-high, open drain 10 = Active-low, push-pull 11 = Active-high, push-pull
		[3:2]	EN_OUT2 Configuration 00 = Active-low, open drain 01 = Active-high, open drain 10 = Active-low, push-pull 11 = Active-high, push-pull
		[5:4]	EN_OUT3 Configuration 00 = Active-low, open drain 01 = Active-high, open drain 10 = Active-low, push-pull 11 = Active-high, push-pull
		[7:6]	EN_OUT4 Configuration 00 = Active-low, open drain 01 = Active-high, open drain 10 = Active-low, push-pull 11 = Active-high, push-pull
31h	231h	[1:0]	EN_OUT5 Configuration 00 = Active-low, open drain 01 = Active-high, open drain 10 = Active-low, push-pull 11 = Active-high, push-pull
		[3:2]	EN_OUT6 Configuration 00 = Active-low, open drain 01 = Active-high, open drain 10 = Active-low, push-pull 11 = Active-high, push-pull
		[7:4]	Not used
33h	233h	[0]	EN_OUT1 Charge-Pump Output Configuration 0 = Charge-pump output disabled 1 = Charge-pump output enabled (active-high)
		[1]	EN_OUT2 Charge-Pump Output Configuration 0 = Charge-pump output disabled 1 = Charge-pump output enabled (active-high)
		[2]	EN_OUT3 Charge-Pump Output Configuration 0 = Charge-pump output disabled 1 = Charge-pump output enabled (active-high)
		[7:3]	Not used



# 6-Channel, Flash-Configurable System Manager with Nonvolatile Fault Registers

## EN\_OUT\_s as GPIO

EN\_OUT1–EN\_OUT6 can be configured as general-purpose inputs by setting the sequencing slot assignments in r84h–r86h to ‘1101’ or as general-purpose outputs by setting the slot assignments to ‘1110’. See Tables 5 and 6. If an EN\_OUT\_ is configured as a general-purpose input, the state of the GPIO can be read from r1Fh (see Table 21). If an EN\_OUT\_ is configured as a general-purpose output, it is controlled by r34h.

## EN\_OUT\_ State During Power-Up

When VCC is ramped from 0V to the operating supply voltage, the EN\_OUT\_ output is high impedance until VCC reaches UVLO and then EN\_OUT\_ goes into the configured deasserted state. See Figures 4 and 5. Configure RESET as an active-low push-pull or open-drain output pulled up to VCC through a 10kΩ resistor for Figures 4 and 5.

**Table 21. EN\_OUT\_ GPIO State Registers**

REGISTER ADDRESS	FLASH ADDRESS	BIT RANGE	DESCRIPTION
1Fh	—	[0]	EN_OUT1 input state
		[1]	EN_OUT2 input state
		[2]	EN_OUT3 input state
		[3]	EN_OUT4 input state
		[4]	EN_OUT5 input state
		[5]	EN_OUT6 input state
		[7:6]	Not used
34h	234h	[0]	1 = Assert EN_OUT1
		[1]	1 = Assert EN_OUT2
		[2]	1 = Assert EN_OUT3
		[3]	1 = Assert EN_OUT4
		[4]	1 = Assert EN_OUT5
		[5]	1 = Assert EN_OUT6
		[7:6]	Not used

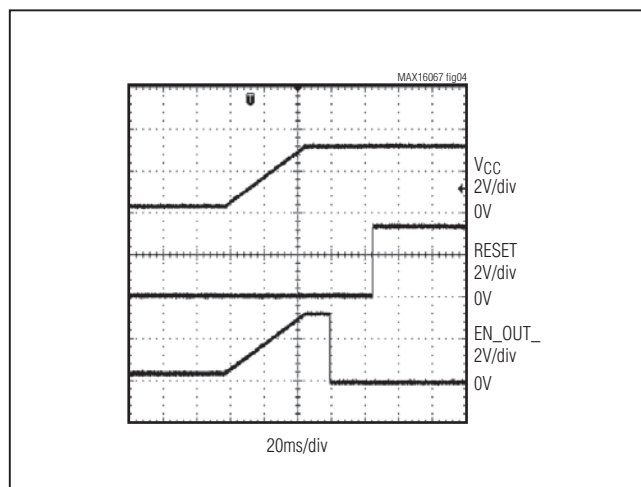

Figure 4. RESET and EN\_OUT\_ During Power-Up, EN\_OUT\_ is in Open-Drain Active-Low Configuration

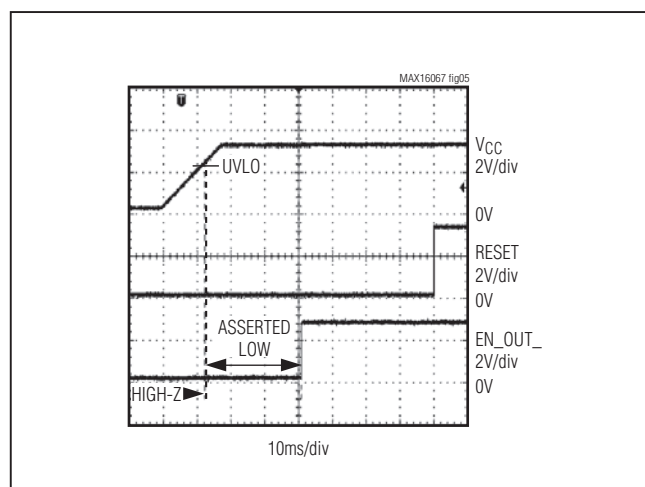

Figure 5. RESET and EN\_OUT\_ During Power-Up, EN\_OUT\_ is in Push-Pull Active-High Configuration

## 6-Channel, Flash-Configurable System Manager with Nonvolatile Fault Registers

### Reset Output

The reset output, RESET, indicates the status of the sequencer and the monitored inputs. It asserts during power-up/power-down and deasserts following the reset timeout period once the power-up sequence is complete. The power-up sequence is complete when any MON\_ inputs assigned to slot 6 exceed the undervoltage thresholds and the slot 6 sequence delay expires. When no MON\_ inputs are assigned to slot 6, the power-up sequence is complete after the slot sequence delay expires.

During normal monitoring, RESET can be configured to assert when any combination of MON\_ inputs violates configurable combinations of undervoltage or overvoltage

thresholds. Select the combination of MON\_ inputs using r3Ch[5:0] and r3Dh[5:0]. Note that MON\_ inputs configured as critical faults always cause RESET to assert regardless of these configuration bits.

RESET can be configured as push-pull or open drain using r3Bh[3], and active high or active low using r3Bh[2]. Select the reset timeout by loading a value from Table 22 into r3Bh[7:4].

To generate a one-shot pulse on RESET, write a '1' into r3Bh[0]. The pulse width is the configured reset timeout. Register bit r3Bh[0] clears automatically (see Table 22). The current state of RESET can be checked by reading r20h[0].

**Table 22. Reset Output Configuration**

REGISTER ADDRESS	FLASH ADDRESS	BIT RANGE	DESCRIPTION
3Bh	23Bh	[0]	RESET Soft Trigger 0 = Normal RESET behavior 1 = Force RESET to assert
		[1]	Not used
		[2]	0 = Active low 1 = Active high
		[3]	0 = Open drain 1 = Push-pull
		[7:4]	Reset Timeout Period 0000 = 25µs 0001 = 1.5ms 0010 = 2.5ms 0011 = 4ms 0100 = 6ms 0101 = 10ms 0110 = 15ms 0111 = 25ms 1000 = 40ms 1001 = 60ms 1010 = 100ms 1011 = 150ms 1100 = 250ms 1101 = 400ms 1110 = 600ms 1111 = 1s

## 6-Channel, Flash-Configurable System Manager with Nonvolatile Fault Registers

Table 22. Reset Output Configuration (continued)

REGISTER ADDRESS	FLASH ADDRESS	BIT RANGE	DESCRIPTION
3Ch	23Ch	[0]	1 = RESET depends on MON1 undervoltage
		[1]	1 = RESET depends on MON2 undervoltage
		[2]	1 = RESET depends on MON3 undervoltage
		[3]	1 = RESET depends on MON4 undervoltage
		[4]	1 = RESET depends on MON5 undervoltage
		[5]	1 = RESET depends on MON6 undervoltage
		[7:6]	Not used
3Dh	23Dh	[0]	1 = RESET depends on MON1 overvoltage
		[1]	1 = RESET depends on MON2 overvoltage
		[2]	1 = RESET depends on MON3 overvoltage
		[3]	1 = RESET depends on MON4 overvoltage
		[4]	1 = RESET depends on MON5 overvoltage
		[5]	1 = RESET depends on MON6 overvoltage
		[7:6]	Not used

### Watchdog Timer

The watchdog timer operates together with or independently of the MAX16067. When operating in dependent mode, the watchdog is not activated until the sequencing is complete and RESET is deasserted. When operating in independent mode, the watchdog timer is independent of the sequencing operation and activates immediately after VCC exceeds the UVLO threshold and the boot phase is complete. Set r73h[4] to '0' to configure the watchdog in dependent mode. Set r73h[4] to '1' to configure the watchdog in independent mode. See Table 23 for more information on configuring the watchdog timer in dependent or independent mode. The watchdog timer can be reset by toggling the WDI input (GPIO4) or by writing a '1' to r75h[5].

### Dependent Watchdog Timer Operation

Use the watchdog timer to monitor  $\mu\text{P}$  activity in two modes. Flexible timeout architecture provides an adjustable watchdog startup delay of up to 300s, allowing complicated systems to complete lengthy boot-up routines. An adjustable watchdog timeout allows the supervisor to provide quick alerts when the processor activity fails. After each reset event (VCC drops below UVLO then returns above UVLO, software reboot, manual reset ( $\overline{\text{MR}}$ ), EN input going low then high, or watchdog reset) and once sequencing is complete, the watchdog startup delay provides an extended time for the system to power

up and fully initialize all  $\mu\text{P}$  and system components before assuming responsibility for routine watchdog updates. Set r76h[6:4] to a value other than '000' to enable the watchdog startup delay. Set r76h[6:4] to '000' to disable the watchdog startup delay.

The normal watchdog timeout period,  $t_{\text{WDI}}$ , begins after the first transition on WDI before the conclusion of the long startup watchdog period,  $t_{\text{WDI\_STARTUP}}$  (Figures 6 and 7). During the normal operating mode,  $\overline{\text{WDO}}$  asserts if the  $\mu\text{P}$  does not toggle WDI with a valid transition (high-to-low or low-to-high) within the standard timeout period,  $t_{\text{WDI}}$ .  $\overline{\text{WDO}}$  remains asserted until WDI is toggled or RESET is asserted (Figure 7).

While EN is low, the watchdog timer is in reset. The watchdog timer does not begin counting until the power-on mode is reached and RESET is deasserted. The watchdog timer is reset and  $\overline{\text{WDO}}$  deasserts any time RESET is asserted (Figure 8). The watchdog timer is held in reset while RESET is asserted.

The watchdog can be configured to control the RESET output as well as the  $\overline{\text{WDO}}$  output. RESET asserts for the reset timeout,  $t_{\text{RP}}$ , when the watchdog timer expires and the Watchdog Reset Output Enable bit (r76h[7]) is set to '1'. When RESET is asserted, the watchdog timer is cleared and  $\overline{\text{WDO}}$  is deasserted, therefore,  $\overline{\text{WDO}}$  pulses low for a short time (approximately 1 $\mu\text{s}$ ) when

# 6-Channel, Flash-Configurable System Manager with Nonvolatile Fault Registers

the watchdog timer expires. RESET is not affected by the watchdog timer when the Watchdog Reset Output Enable bit (r76h[7]) is set to '0'. If a RESET is asserted by the watchdog timeout, the WDRESET bit is set to '1'. A connected processor can check this bit to see the reset was due to a watchdog timeout.

See Table 23 for more information on configuring watchdog functionality.

### Independent Watchdog Timer Operation

When r73h[4] is '1,' the watchdog timer operates in the independent mode. In the independent mode, the watchdog timer operates as if it were a separate device. The watchdog timer is activated immediately upon VCC

exceeding UVLO and once the boot-up sequence is finished. When RESET is asserted by the sequencer state machine, the watchdog timer and  $\overline{WDO}$  are not affected.

There is a startup delay if r76h[6:4] is set to a value different than '000'. If r76h[6:4] is set to '000', there is not a startup delay. See Table 23 for delay times.

In independent mode, if the Watchdog Reset Output Enable bit (r76h[7]) is set to '1,' when the watchdog timer expires,  $\overline{WDO}$  asserts then RESET asserts.  $\overline{WDO}$  is then deasserts.  $\overline{WDO}$  is low for approximately 1 $\mu$ s. If the Watchdog Reset Output Enable bit (r76h[7]) is set to '0,' when the watchdog timer expires,  $\overline{WDO}$  asserts but RESET is not affected.

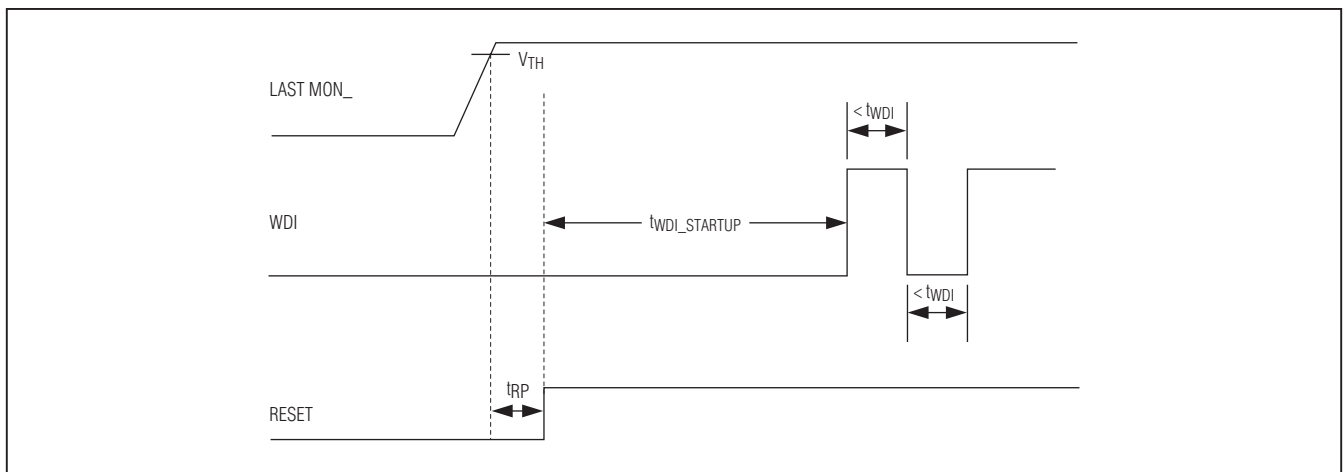

Figure 6. Normal Watchdog Startup Sequence

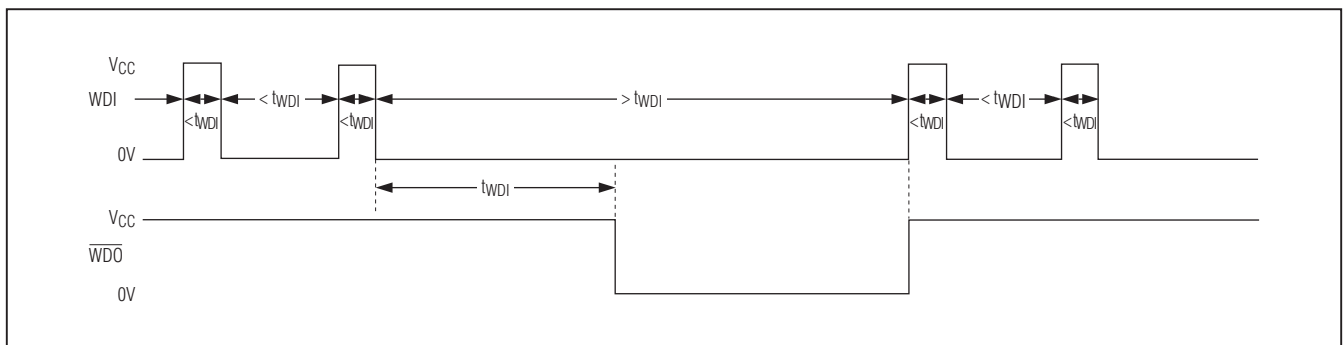

Figure 7. Watchdog Timer Operation

## 6-Channel, Flash-Configurable System Manager with Nonvolatile Fault Registers

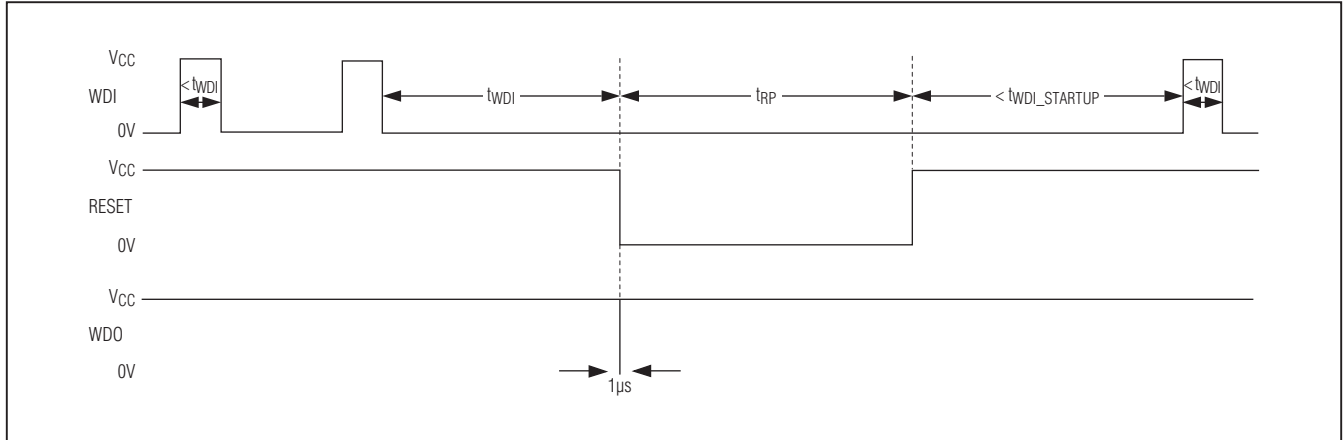

Figure 8. Watchdog Startup Sequence with Watchdog Reset Output Enable Bit Set to '1'

**Table 23. Watchdog Configuration**

REGISTER ADDRESS	FLASH ADDRESS	BIT RANGE	DESCRIPTION
73h	273h	[4]	1 = Independent mode 0 = Dependent mode
76h	276h	[7]	1 = Watchdog reset output enabled 0 = Watchdog reset output disabled
		[6:4]	Watchdog Startup Delay 000 = No initial timeout 001 = 30s 010 = 40s 011 = 80s 100 = 120s 101 = 160s 110 = 220s 111 = 300s
		[3:0]	Watchdog Timeout 0000 = Watchdog disabled 0001 = 1ms 0010 = 2ms 0011 = 4ms 0100 = 8ms 0101 = 14ms 0110 = 27ms 0111 = 50ms 1000 = 100ms 1001 = 200ms 1010 = 400ms 1011 = 750ms 1100 = 1.4s 1101 = 2.7s 1110 = 5s 1111 = 10s

## 6-Channel, Flash-Configurable System Manager with Nonvolatile Fault Registers

### User-Defined Register

Register r8Ah provides storage space for a user-defined configuration or firmware version number. Note that this register controls the contents of the JTAG USERCODE register bits 7-0. The user-defined register is stored at r28Ah in the flash memory.

### Memory Lock Bits

Register r8Ch contains the lock bits for the configuration registers, configuration flash, user flash, and fault register lock. See Table 24 for details.

### SMBus-Compatible Serial Interface

The MAX16067 features an SMBus-compatible, 2-wire serial interface consisting of a serial-data line (SDA) and a serial-clock line (SCL). SDA and SCL facilitate bidirectional communication between the MAX16067 and the master device at clock rates up to 400kHz. Figure 1 shows the 2-wire interface timing diagram. The MAX16067 is a transmit/receive, slave-only device, relying upon a master device to generate a clock signal. The master device (typically a microcontroller) initiates a data transfer on the bus and generates SCL to permit that transfer.

A master device communicates to the MAX16067 by transmitting the proper address followed by command and/or data words. The slave address input, AO, is capable of detecting four different states, allowing multiple identical devices to share the same serial bus. The slave address is described further in the *Slave Address* section. Each transmit sequence is framed by a START

(S) or REPEATED START (Sr) condition and a STOP (P) condition. Each word transmitted over the bus is 8 bits long and is always followed by an acknowledge pulse. SCL is a logic input, while SDA is an open-drain input/output. SCL and SDA both require external pullup resistors to generate the logic-high voltage. Use 4.7kΩ for most applications.

### Bit Transfer

Each clock pulse transfers one data bit. The data on SDA must remain stable while SCL is high (Figure 9); otherwise, the MAX16067 registers a START or STOP condition (Figure 10) from the master. SDA and SCL idle high when the bus is not busy.

### START and STOP Conditions

A master device signals the beginning of a transmission with a START condition by transitioning SDA from high to low while SCL is high. The master device issues a STOP condition by transitioning SDA from low to high while SCL is high. A STOP condition frees the bus for another transmission. The bus remains active if a REPEATED START condition is generated, such as in the block read protocol (see Figure 1, SMBus Timing Diagram).

### Early STOP Conditions

The MAX16067 recognizes a STOP condition at any point during transmission except if a STOP condition occurs in the same high pulse as a START condition. This condition is not a legal SMBus format; at least one clock pulse must separate any START and STOP condition.

**Table 24. Memory Lock Bits**

REGISTER ADDRESS	FLASH ADDRESS	BIT RANGE	DESCRIPTION
8Ch	28Ch	[0]	Configuration Register Lock 1 = Locked 0 = Unlocked
		[1]	Flash Fault Register Lock 1 = Locked 0 = Unlocked
		[2]	Flash Configuration Lock 1 = Locked 0 = Unlocked
		[3]	User Flash Lock 1 = Locked 0 = Unlocked
		[7.4]	Not used

# 6-Channel, Flash-Configurable System Manager with Nonvolatile Fault Registers

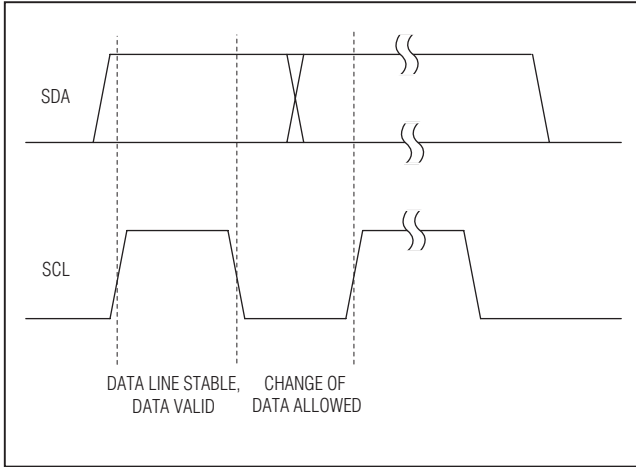

Figure 9. Bit Transfer

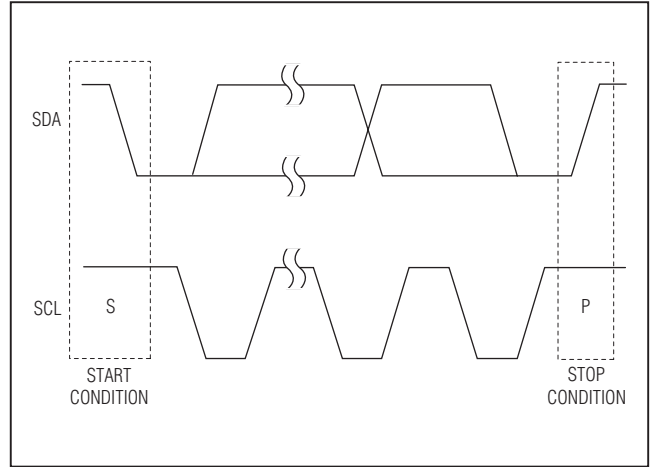

Figure 10. START and STOP Conditions

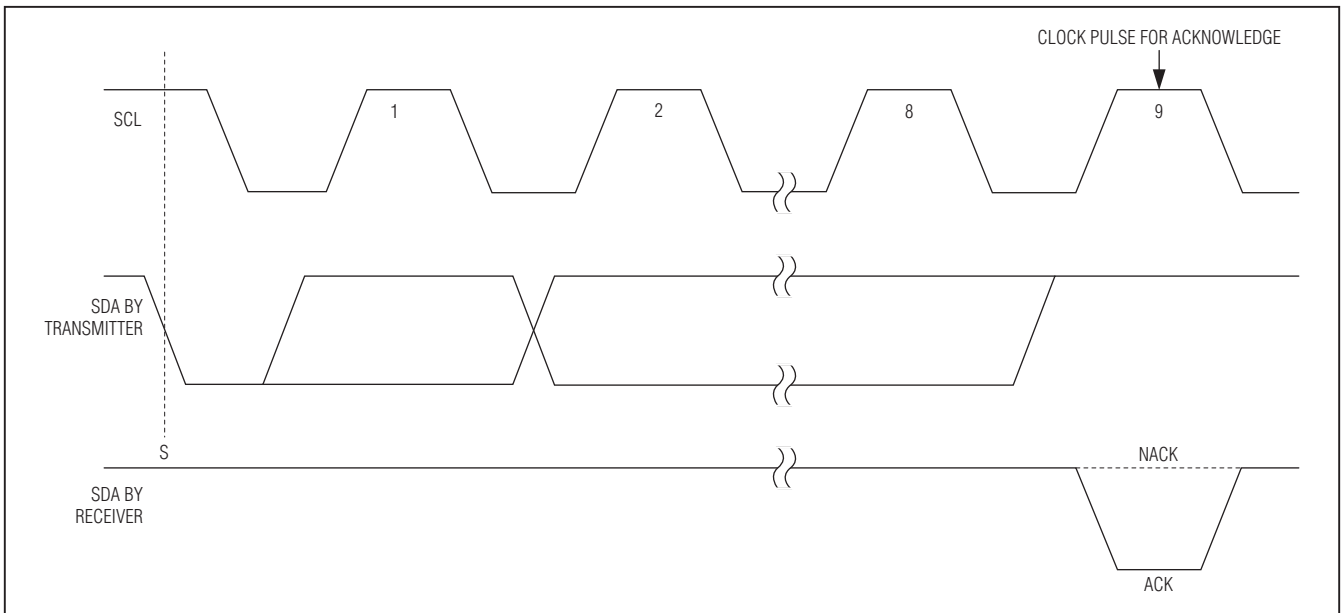

Figure 11. Acknowledge

### REPEATED START Conditions

A REPEATED START can be sent instead of a STOP condition to maintain control of the bus during a read operation. The START and REPEATED START conditions are functionally identical.

### Acknowledge

The acknowledge bit (ACK) is the 9th bit attached to any 8-bit data word. The receiving device always generates an ACK. The MAX16067 generates an ACK when receiving an address or data by pulling SDA low during the 9th clock period (Figure 11). When transmitting data,

such as when the master device reads data back from the MAX16067, the device waits for the master device to generate an ACK. Monitoring ACK allows for detection of unsuccessful data transfers. An unsuccessful data transfer occurs if the receiving device is busy or if a system fault has occurred. In the event of an unsuccessful data transfer, the bus master can reattempt communication at a later time. The MAX16067 generates a NACK after the command byte received during a software reboot, while writing to the flash, or when receiving an illegal memory address.

## 6-Channel, Flash-Configurable System Manager with Nonvolatile Fault Registers

### Slave Address

Use the slave address input, A0, to allow multiple identical devices to share the same serial bus. Connect A0 to GND, DBP (or an external supply voltage greater than 2V), SCL, or SDA to set the device address on the bus. See Table 26 for a listing of all possible 7-bit addresses.

The slave address can also be set to a custom value by loading the address into register r8Bh[6:0]. See Table 25. If r8Bh[6:0] is loaded with 00h, the address is set by input A0. Do not set the address to 09h or 7Fh to avoid address conflicts. The slave address setting takes effect immediately after writing to the register.

### Packet Error Checking (PEC)

The MAX16067 features a packet-error checking (PEC) mode that is useful to improve the reliability of the communication bus by detecting bit errors. By enabling PEC, an extra CRC-8 error check byte is added in the data string during each read and/or write sequence. Enable PEC by writing a '1' to r8Bh[7].

The CRC-8 byte is calculated using the polynomial  

$$C = X^8 + X^2 + X + 1$$

The PEC calculation includes all bytes in the transmission, including address, command, and data. The PEC

calculation does not include ACK, NACK, START, STOP, or REPEATED START.

### Command Codes

The MAX16067 uses eight command codes for block read, block write, and other commands. See Table 27 for a list of command codes.

To initiate a software reboot, send A7h using the send byte format. A software-initiated reboot is functionally the same as a hardware-initiated power-on reset. During boot-up, flash configuration data in the range of 230h–28Ch is copied to r30h–r8Ch registers in the default page.

Send command code A8h to trigger a fault store to flash. Configure the Critical Fault Log Control register (6Dh) to store ADC conversion results and/or fault flags.

While in the flash page, send command code A9h to access the flash page (addresses from 200h–2FFh). Once command code A9h has been sent, all addresses are recognized as flash addresses only. Send command code AAh to return to the default page (addresses from 000h–0FFh). Send command code ABh to access the user flash-page (addresses from 300h–3FFh), and send command code ACh to return to the flash page.

**Table 25. SMBus Settings Register**

REGISTER ADDRESS	FLASH ADDRESS	BIT RANGE	DESCRIPTION
8Bh	28Bh	[6:0]	SMBus Slave Address Register. Set to 00h to use A0 pin address setting.
		[7]	1 = Enable PEC (Packet Error Check).

**Table 26. Setting the SMBus Slave Address**

SLAVE ADDRESSES	
A0	SLAVE ADDRESS
0	1010 100R
1	1010 101R
SCL	1010 110R
SDA	1010 111R

R = Read/write select bit.



## 6-Channel, Flash-Configurable System Manager with Nonvolatile Fault Registers

**Table 27. Command Codes**

COMMAND CODE	ACTION
A5h	Block write
A6h	Block read
A7h	Reboot flash in register file
A8h	Trigger emergency save to flash
A9h	Flash page access ON
AAh	Flash page access OFF
ABh	User flash access ON (must be in flash page already)
ACH	User flash access OFF (return to flash page)

### **Restrictions When Writing to Flash**

Flash must be written to 8 bytes at a time. The initial address must be aligned to 8-byte boundaries—the 3 LSBs of the initial address must be '000'. Write the 8 bytes using a single block write command or using eight successive Write Byte commands. A write operation requires 122ms for each 8-byte block. After programming a block, check r20h[1] (see Table 31) to make sure the write operation is complete before attempting to write the next block.

### **Send Byte**

The send byte protocol allows the master device to send one byte of data to the slave device (see Figure 12). The send byte presets a register pointer address for a subsequent read or write. The slave sends a NACK instead of an ACK if the master tries to send a memory address or command code that is not allowed. If the master sends A5h or A6h, the data is ACK, because this could be the start of the write block or read block. If the master sends a STOP condition before the slave asserts an ACK, the internal address pointer does not change. If the master sends A7h, this signifies a software reboot. The send byte procedure is as follows:

- 1) The master sends a START condition.
- 2) The master sends the 7-bit slave address and a write bit (low).
- 3) The addressed slave asserts an ACK on SDA.
- 4) The master sends an 8-bit memory address or command code.
- 5) The addressed slave asserts an ACK (or NACK) on SDA.
- 6) The master sends a STOP condition.

### **Receive Byte**

The receive byte protocol allows the master device to read the register content of the MAX16067 (see Figure 12). The flash or register address must be preset with a send byte or write word protocol first. Once the read is complete, the internal pointer increases by one. Repeating the receive byte protocol reads the contents of the next address. The receive byte procedure follows:

- 1) The master sends a START condition.
- 2) The master sends the 7-bit slave address and a read bit (high).
- 3) The addressed slave asserts an ACK on SDA.
- 4) The slave sends 8 data bits.
- 5) The master asserts a NACK on SDA.
- 6) The master generates a STOP condition.

### **Write Byte**

The write byte protocol (see Figure 12) allows the master device to write a single byte in the default page, extended page, or flash page, depending on which page is currently selected. The write byte procedure is as follows:

- 1) The master sends a START condition.
- 2) The master sends the 7-bit slave address and a write bit (low).
- 3) The addressed slave asserts an ACK on SDA.
- 4) The master sends an 8-bit memory address.
- 5) The addressed slave asserts an ACK on SDA.
- 6) The master sends an 8-bit data byte.
- 7) The addressed slave asserts an ACK on SDA.
- 8) The master sends a STOP condition.

## 6-Channel, Flash-Configurable System Manager with Nonvolatile Fault Registers

To write a single byte, only the 8-bit memory address and a single 8-bit data byte are sent. The data byte is written to the addressed location if the memory address is valid. The slave asserts a NACK at step 5 if the memory address is not valid.

When PEC is enabled, the write byte protocol becomes:

- 1) The master sends a START condition.
- 2) The master sends the 7-bit slave ID plus a write bit (low).
- 3) The addressed slave asserts an ACK on the data line.
- 4) The master sends an 8-bit memory address.
- 5) The active slave asserts an ACK on the data line.
- 6) The master sends an 8-bit data byte.
- 7) The slave asserts an ACK on the data line.
- 8) The master sends an 8-bit PEC byte.
- 9) The slave asserts an ACK on the data line (if PEC is good, otherwise NACK).
- 10) The master generates a STOP condition.

### Read Byte

The read byte protocol (see Figure 12) allows the master device to read a single byte located in the default page, extended page, or flash page depending on which page is currently selected. The read byte procedure is as follows:

- 1) The master sends a START condition.
- 2) The master sends the 7-bit slave address and a write bit (low).
- 3) The addressed slave asserts an ACK on SDA.
- 4) The master sends an 8-bit memory address.
- 5) The addressed slave asserts an ACK on SDA.
- 6) The master sends a REPEATED START condition.
- 7) The master sends the 7-bit slave address and a read bit (high).
- 8) The addressed slave asserts an ACK on SDA.
- 9) The slave sends an 8-bit data byte.
- 10) The master asserts a NACK on SDA.
- 11) The master sends a STOP condition.

If the memory address is not valid, it is NACKed by the slave at step 5 and the address pointer is not modified.

When PEC is enabled, the read byte protocol becomes:

- 1) The master sends a START condition.
- 2) The master sends the 7-bit slave ID plus a write bit (low).
- 3) The addressed slave asserts an ACK on the data line.
- 4) The master sends 8-bit memory address.
- 5) The active slave asserts an ACK on the data line.
- 6) The master sends a REPEATED START condition.
- 7) The master sends the 7-bit slave ID plus a read bit (high).
- 8) The addressed slave asserts an ACK on the data line.
- 9) The slave sends 8 data bits.
- 10) The master asserts an ACK on the data line.
- 11) The slave sends an 8-bit PEC byte.
- 12) The master asserts a NACK on the data line.
- 13) The master generates a STOP condition.

### Block Write

The block write protocol (see Figure 12) allows the master device to write a block of data (1–16 bytes) to memory. Preload the destination address by a previous send byte command; otherwise the block write command begins to write at the current address pointer. After the last byte is written, the address pointer remains preset to the next valid address. If the number of bytes to be written causes the address pointer to exceed 8Fh for configuration registers or configuration flash or FFh for user flash, the address pointer stays at 8Fh or FFh, respectively, overwriting this memory address with the remaining bytes of data. The slave generates a NACK at step 5 if the command code is invalid or if the device is busy, and the address pointer is not altered.

The block write procedure is as follows:

- 1) The master sends a START condition.
- 2) The master sends the 7-bit slave address and a write bit (low).
- 3) The addressed slave asserts an ACK on SDA.
- 4) The master sends the 8-bit command code for block write (A5h).
- 5) The addressed slave asserts an ACK on SDA.

## 6-Channel, Flash-Configurable System Manager with Nonvolatile Fault Registers

- 6) The master sends the 8-bit byte count (1 byte to 16 bytes), n.
- 7) The addressed slave asserts an ACK on SDA.
- 8) The master sends 8 bits of data.
- 9) The addressed slave asserts an ACK on SDA.
- 10) Repeat steps 8 and 9 n - 1 times.
- 11) The master sends a STOP condition.

When PEC is enabled, the block write protocol becomes:

- 1) The master sends a START condition.
- 2) The master sends the 7-bit slave ID plus a write bit (low).
- 3) The addressed slave asserts an ACK on the data line.
- 4) The master sends 8 bits of the block write command code.
- 5) The slave asserts an ACK on the data line.
- 6) The master sends 8 bits byte count (min 1, max 16) n.
- 7) The slave asserts an ACK on the data line.
- 8) The master sends 8 bits of data.
- 9) The slave asserts an ACK on the data line.
- 10) Repeat 8 and 9 n - 1 times.
- 11) The master sends an 8-bit PEC byte.
- 12) The slave asserts an ACK on the data line (if PEC is good, otherwise NACK).
- 13) The master generates a STOP condition.

### Block Read

The block read protocol (see Figure 12) allows the master device to read a block of up to 16 bytes from memory. Read fewer than 16 bytes of data by issuing an early STOP condition from the master, or by generating a NACK with the master. The destination address should be preloaded by a previous send byte command; otherwise, the block read command begins to read at the current address pointer. If the number of bytes to be read causes the address pointer to exceed 8Fh for the configuration register or configuration flash or FFh in user flash, the address pointer stays at 8Fh or FFh, respectively.

The block read procedure is the following:

- 1) The master sends a START condition.
- 2) The master sends the 7-bit slave address and a write bit (low).

- 3) The addressed slave asserts an ACK on SDA.
- 4) The master sends 8 bits of the block read command (95h).
- 5) The slave asserts an ACK on SDA, unless busy.
- 6) The master generates a REPEATED START condition.
- 7) The master sends the 7-bit slave address and a read bit (high).
- 8) The slave asserts an ACK on SDA.
- 9) The slave sends the 8-bit byte count (16).
- 10) The master asserts an ACK on SDA.
- 11) The slave sends 8 bits of data.
- 12) The master asserts an ACK on SDA.
- 13) Repeat steps 11 and 12 up to fifteen times.
- 14) The master asserts a NACK on SDA.
- 15) The master sends a STOP condition.

When PEC is enabled, the block read protocol becomes:

- 1) The master sends a START condition.
- 2) The master sends the 7-bit slave ID plus a write bit (low).
- 3) The addressed slave asserts an ACK on the data line.
- 4) The master sends 8 bits of the block read command code.
- 5) The slave asserts an ACK on the data line unless busy.
- 6) The master sends a REPEATED START condition.
- 7) The master sends the 7-bit slave ID plus a read bit (high).
- 8) The slave asserts an ACK on the data line.
- 9) The slave sends 8-bit byte count (16).
- 10) The master asserts an ACK on the data line.
- 11) The slave sends 8 bits of data.
- 12) The master asserts an ACK on the data line.
- 13) Repeat 11 and 12 up to 15 times.
- 14) The slave sends an 8-bit PEC byte.
- 15) The master asserts a NACK on the data line.
- 16) The master generates a STOP condition.

# 6-Channel, Flash-Configurable System Manager with Nonvolatile Fault Registers

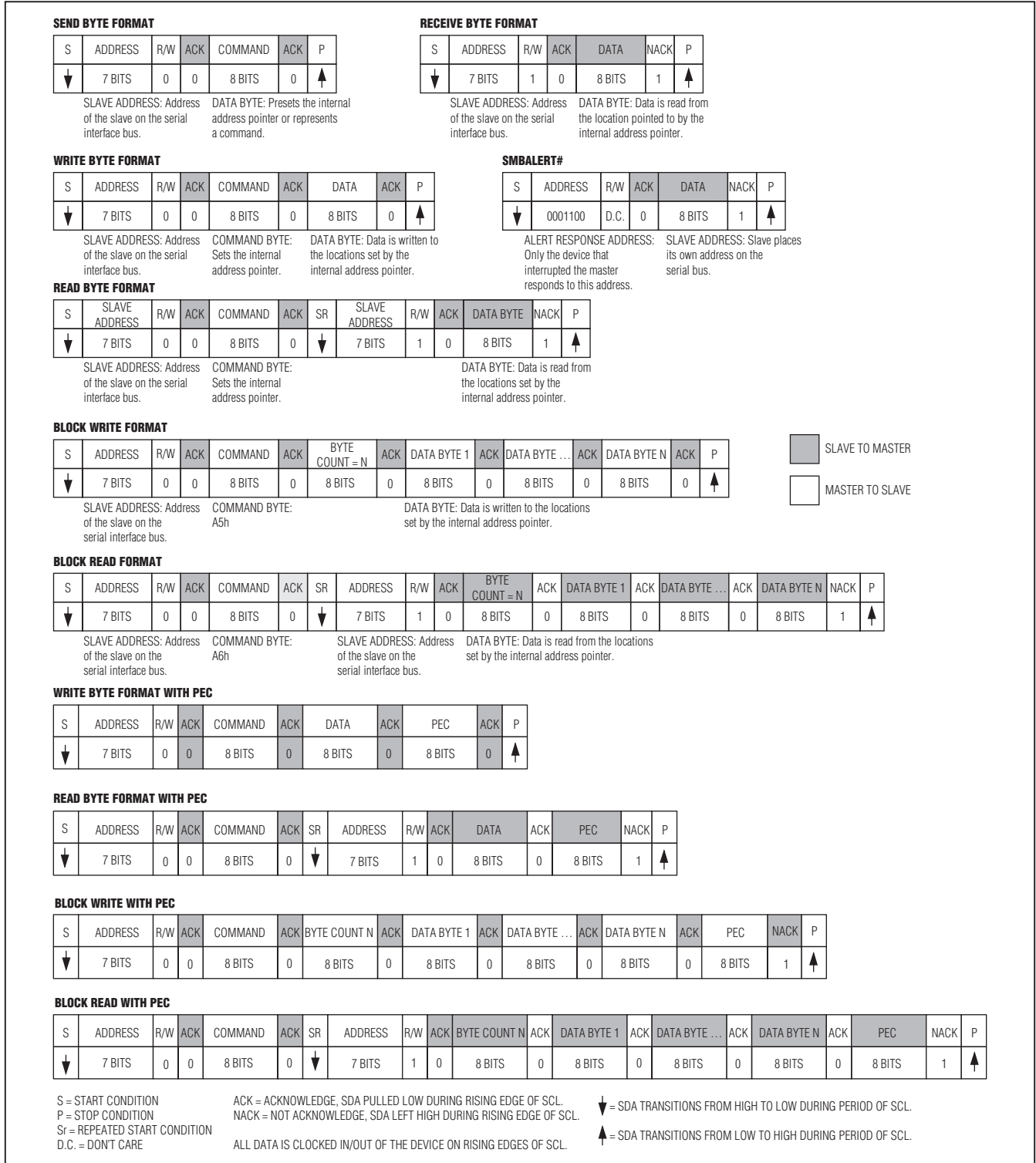

Figure 12. SMBus Protocols

# 6-Channel, Flash-Configurable System Manager with Nonvolatile Fault Registers

## SMBALERT (ALERT)

The MAX16067 supports the SMBus alert protocol. To enable the SMBus alert output, set r40h[4] to '1', then configure GPIO1 to act as the SMBus alert (ALERT) according to Table 11. This output is open drain and uses the wired-OR configuration with other devices on the SMBus. During a fault, the MAX16067 asserts  $\overline{\text{ALERT}}$  low, signaling the master that an interrupt has occurred. The master responds by sending the ARA (Alert Response Address) protocol on the SMBus. This protocol is a read byte with 09h as the slave address. The slave acknowledges the ARA (09h) address and sends its own SMBus address to the master. The slave then deasserts  $\overline{\text{ALERT}}$ . The master can then query the slave and determine the cause of the fault. By checking r1C[7], the master can confirm that the MAX16067 trig-

gered the SMBus alert. The master must send the ARA before clearing r1Ch[7]. Clear r1Ch[7] by writing a '1'. If GPIO1 is configured as the SMBus alert output but the SMBus alert feature is disabled (r40h[4] is set to '0'), GPIO1 acts as an additional fault output.

## JTAG Serial Interface

The MAX16067 features a JTAG port that complies with a subset of the IEEE® 1149.1 specification. Either the SMBus or the JTAG interface can be used to access internal memory; however, only one interface is allowed to run at a time. The MAX16067 contains extra JTAG instructions and registers not included in the JTAG specification that provide access to internal memory. The extra instructions include LOAD ADDRESS, WRITE DATA, READ DATA, REBOOT, and SAVE.

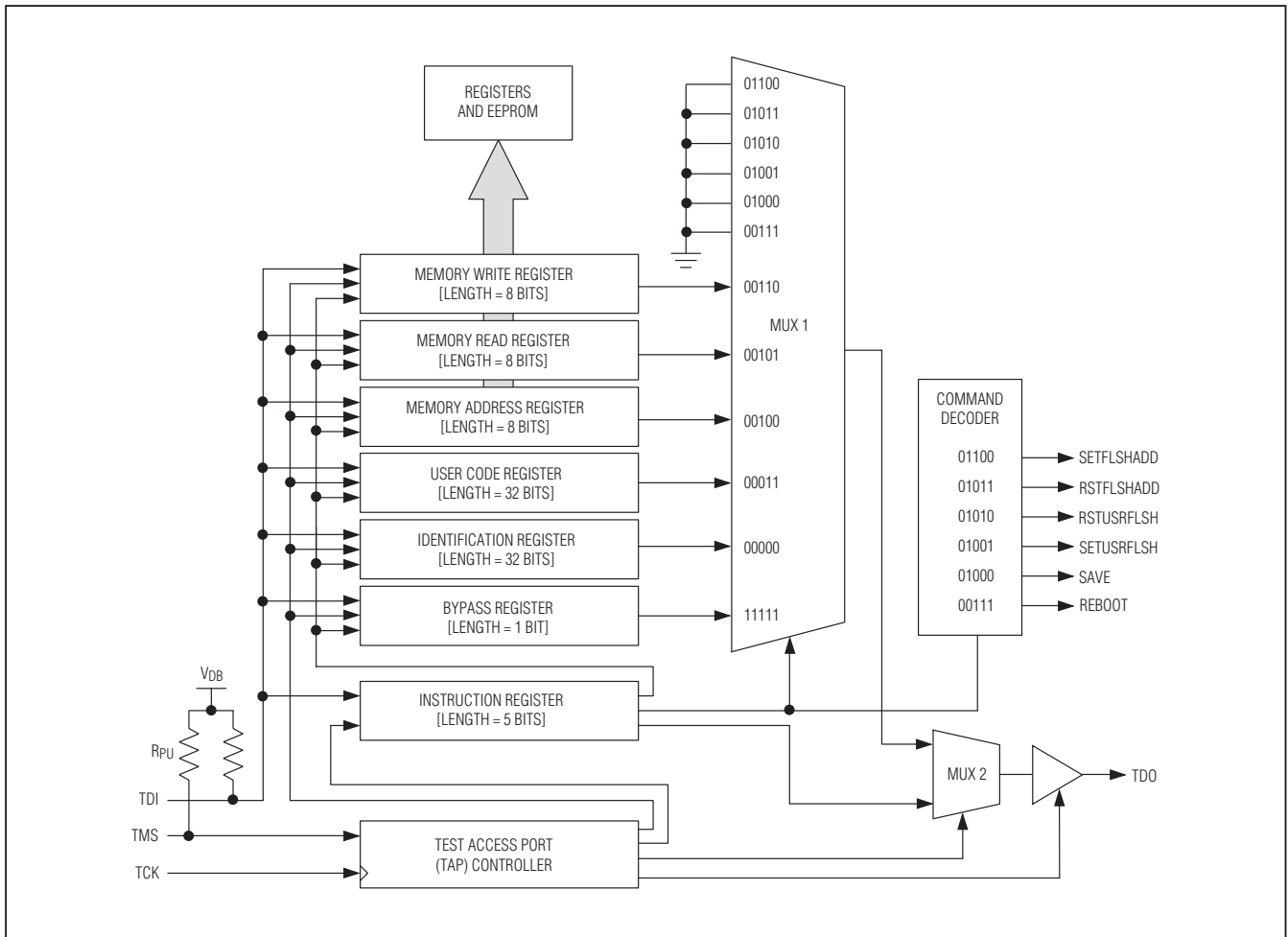

Figure 13. JTAG Block Diagram

IEEE is a registered trademark of the Institute of Electrical and Electronics Engineers, Inc.

## 6-Channel, Flash-Configurable System Manager with Nonvolatile Fault Registers

### Test Access Port (TAP) Controller State Machine

The TAP controller is a finite state machine that responds to the logic level at TMS on the rising edge of TCK. See Figure 14 for a diagram of the finite state machine. The possible states are described as follows:

**Test-Logic-Reset:** At power-up, the TAP controller is in the test-logic-reset state. The instruction register contains the IDCODE instruction. All system logic of the device operates normally. This state can be reached from any state by driving TMS high for five clock cycles.

**Run-Test/Idle:** The run-test/idle state is used between scan operations or during specific tests. The instruction register and test data registers remain idle.

**Select-DR-Scan:** All test data registers retain their previous state. With TMS low, a rising edge of TCK moves the controller into the capture-DR state and initiates a scan sequence. TMS high during a rising edge on TCK moves the controller to the select-IR-scan state.

**Capture-DR:** Data can be parallel-loaded into the test data registers selected by the current instruction. If the

instruction does not call for a parallel load or the selected test data register does not allow parallel loads, the test data register remains at its current value. On the rising edge of TCK, the controller goes to the shift-DR state if TMS is low or it goes to the exit1-DR state if TMS is high.

**Shift-DR:** The test data register selected by the current instruction connects between TDI and TDO and shifts data one stage toward its serial output on each rising edge of TCK while TMS is low. On the rising edge of TCK, the controller goes to the exit1-DR state if TMS is high.

**Exit1-DR:** While in this state, a rising edge on TCK puts the controller in the update-DR state. A rising edge on TCK with TMS low puts the controller in the pause-DR state.

**Pause-DR:** Shifting of the test data registers halts while in this state. All test data registers retain their previous state. The controller remains in this state while TMS is low. A rising edge on TCK with TMS high puts the controller in the exit2-DR state.

**Exit2-DR:** A rising edge on TCK with TMS high while in this state puts the controller in the update-DR state. A rising edge on TCK with TMS low enters the shift-DR state.

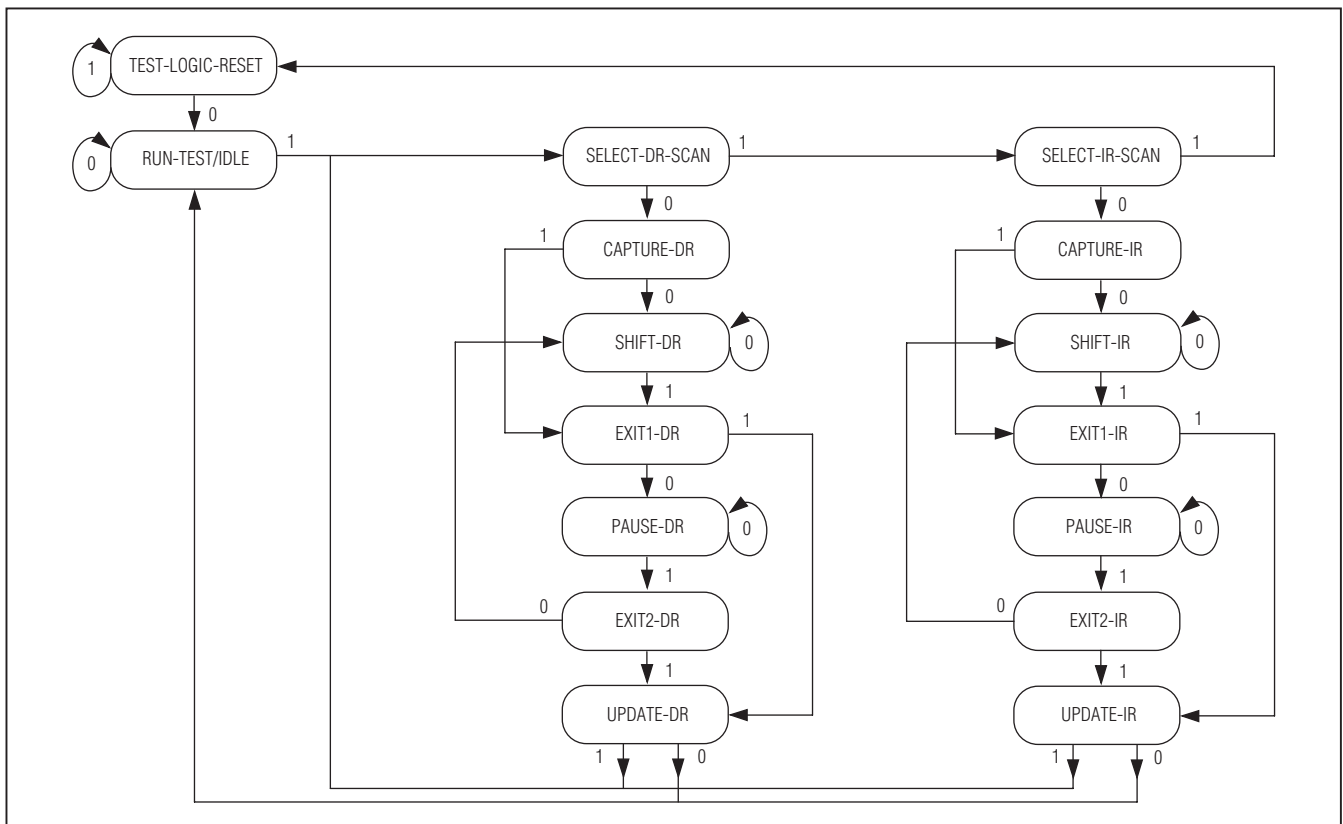

Figure 14. Tap Controller State Diagram



## 6-Channel, Flash-Configurable System Manager with Nonvolatile Fault Registers

**Update-DR:** A falling edge on TCK while in the update-DR state latches the data from the shift register path of the test data registers into a set of output latches. This prevents changes at the parallel output because of changes in the shift register. On the rising edge of TCK, the controller goes to the run-test/idle state if TMS is low or goes to the select-DR-scan state if TMS is high.

**Select-IR-Scan:** All test data registers retain the previous states. The instruction register remains unchanged during this state. With TMS low, a rising edge on TCK moves the controller into the capture-IR state. TMS high during a rising edge on TCK puts the controller back into the test-logic-reset state.

**Capture-IR:** Use the capture-IR state to load the shift register in the instruction register with a fixed value. This value is loaded on the rising edge of TCK. If TMS is high on the rising edge of TCK, the controller enters the exit1-IR state. If TMS is low on the rising edge of TCK, the controller enters the shift-IR state.

**Shift-IR:** In this state, the shift register in the instruction register connects between TDI and TDO and shifts data one stage for every rising edge of TCK toward the TDO serial output while TMS is low. The parallel outputs of the instruction register as well as all test data registers remain at the previous states. A rising edge on TCK with TMS high moves the controller to the exit1-IR state. A rising edge on TCK with TMS low keeps the controller in the shift-IR state while moving data one stage through the instruction shift register.

**Exit1-IR:** A rising edge on TCK with TMS low puts the controller in the pause-IR state. If TMS is high on the rising edge of TCK, the controller enters the update-IR state.

**Pause-IR:** Shifting of the instruction shift register halts temporarily. With TMS high, a rising edge on TCK puts the controller in the exit2-IR state. The controller remains in the pause-IR state if TMS is low during a rising edge on TCK.

**Exit2-IR:** A rising edge on TCK with TMS high puts the controller in the update-IR state. The controller loops back to shift-IR if TMS is low during a rising edge of TCK in this state.

**Update-IR:** The instruction code that has been shifted into the instruction shift register latches to the parallel outputs of the instruction register on the falling edge of TCK as the controller enters this state. Once latched, this instruction becomes the current instruction. A rising edge on TCK with TMS low puts the controller in the run-test/idle state. With TMS high, the controller enters the select-DR-scan state.

### Instruction Register

The instruction register contains a shift register as well as a latched 5-bit wide parallel output. When the TAP controller enters the shift-IR state, the instruction shift register connects between TDI and TDO. While in the shift-IR state, a rising edge on TCK with TMS low shifts the data one stage toward the serial output at TDO. A rising edge on TCK in the exit1-IR state or the exit2-IR state with TMS high moves the controller to the update-IR state. The falling edge of that same TCK latches the data in the instruction shift register to the instruction register parallel output. Table 28 shows the instructions supported by the MAX16067 and the respective operational binary codes.

**Table 28. JTAG Instruction Set**

INSTRUCTION	CODE	NOTES
BYPASS	0x1F	Mandatory instruction code
IDCODE	0x00	Load manufacturer ID code/part number
USERCODE	0x03	Load user code
LOAD ADDRESS	0x04	Load address register content
READ DATA	0x05	Read data pointed by current address
WRITE DATA	0x06	Write data pointed by current address
REBOOT	0x07	Reboot FLASH data content into register file
SAVE	0x08	Trigger emergency save to flash
SETFLSHADD	0x09	Flash page access ON
RSTFLSHADD	0x0A	Flash page access OFF
SETUSRFLSH	0x0B	User flash access ON (must be in flash page already)
RSTUSRFLSH	0x0C	User flash access OFF (return to flash page)

## 6-Channel, Flash-Configurable System Manager with Nonvolatile Fault Registers

**BYPASS:** When the BYPASS instruction is latched into the instruction register, TDI connects to TDO through the 1-bit bypass test data register. This allows data to pass from TDI to TDO without affecting the device's operation.

**IDCODE:** When the IDCODE instruction is latched into the parallel instruction register, the identification data register is selected. The device identification code is loaded into the identification data register on the rising edge of TCK following entry into the capture-DR state. Shift-DR can be used to shift the identification code out serially through TDO. During test-logic-reset, the IDCODE instruction is forced into the instruction register. The identification code always has a '1' in the LSB position. The next 11 bits identify the manufacturer's JEDEC number and number of continuation bytes followed by 16 bits for the device and 4 bits for the version. See Table 29.

**USERCODE:** When the USERCODE instruction latches into the parallel instruction register, the user-code data register is selected. The device user-code loads into the user-code data register on the rising edge of TCK following entry into the capture-DR state. Shift-DR can be used to shift the user-code out serially through TDO. See Table 30. This instruction can be used to help identify multiple MAX16067 devices connected in a JTAG chain.

**LOAD ADDRESS:** This is an extension to the standard IEEE 1149.1 instruction set to support access to the

memory in the MAX16067. When the LOAD ADDRESS instruction latches into the instruction register, TDI connects to TDO through the 8-bit memory address test data register during the shift-DR state.

**READ DATA:** This is an extension to the standard IEEE 1149.1 instruction set to support access to the memory in the MAX16067. When the READ DATA instruction latches into the instruction register, TDI connects to TDO through the 8-bit memory read test data register during the shift-DR state.

**WRITE DATA:** This is an extension to the standard IEEE 1149.1 instruction set to support access to the memory in the MAX16067. When the WRITE DATA instruction latches into the instruction register, TDI connects to TDO through the 8-bit memory write test data register during the shift-DR state.

**REBOOT:** This is an extension to the standard IEEE 1149.1 instruction set to initiate a software controlled reset to the MAX16067. When the REBOOT instruction latches into the instruction register, the MAX16067 resets and immediately begins the boot-up sequence.

**SAVE:** This is an extension to the standard IEEE 1149.1 instruction set that triggers a fault log. The current ADC conversion results along with fault information are saved to flash depending on the configuration of the Critical Fault Log Control register (r6Dh).

**Table 29. 32-Bit Identification Code**

MSB			LSB
VERSION (4 BITS)	PART NUMBER (16 BITS)	MANUFACTURER (11 BITS)	FIXED VALUE (1 BIT)
0001	1000000000000000	00011001011	1

**Table 30. 32-Bit User-Code Data**

MSB		LSB						
DON'T CARE	SMBUS SLAVE ID	USER ID (r8Ah[7:0])						
0000000000000000	See Table 26							



## 6-Channel, Flash-Configurable System Manager with Nonvolatile Fault Registers

**SETFLSHADD:** This is an extension to the standard IEEE 1149.1 instruction set that allows access to the flash page. Flash registers include ADC conversion results, and GPIO\_ input/output data. Use this page to access registers 200h–2FFh.

**RSTFLSHADD:** This is an extension to the standard IEEE 1149.1 instruction set. Use RSTFLSHADD to return to the default page and disable access to the flash page.

**SETUSRFLSH:** This is an extension to the standard IEEE 1149.1 instruction set that allows access to the user flash page. When on the configuration flash page, send the SETUSRFLSH command, all addresses are recognized as flash addresses only. Use this page to access registers 300h–3FFh.

**RSTUSRFLSH:** This is an extension to the standard IEEE 1149.1 instruction set. Use RSTUSRFLSH to return to the configuration flash page and disable access to the user flash.

### Restrictions When Writing to Flash

Flash must be written to 8 bytes at a time. The initial address must be aligned to 8-byte boundaries—the 3 LSBs of the initial address must be '000'. Write the 8 bytes using 8 successive WRITE DATA commands. A write operation requires 122ms for each 8-byte block. After programming a block, check r20h[1] (see Table 31) to make sure the write operation is complete before attempting to write the next block.

## Applications Information

### Unprogrammed Device Behavior

When the flash has not been programmed using the JTAG or SMBus interface, the default configuration of the EN\_OUT\_ outputs is open drain active low. This means that the EN\_OUT\_ outputs are high impedance.

When it is necessary to hold an EN\_OUT\_ high or low to prevent premature startup of a power supply before the flash is programmed, connect a resistor from EN\_OUT\_ to ground or the supply voltage. Avoid connecting a resistor to ground when the output is to be configured as open drain with a separate pullup resistor.

### Device Behavior at Power-Up

When VCC is ramped from 0V, the RESET output is high impedance until VCC reaches 1.4V, at which point RESET goes low. All other outputs are high impedance until VCC reaches 2.7V, then the flash contents are copied into register memory. This takes 150μs (max) after which the outputs assume their programmed states.

### Programming the MAX16067 in Circuit

The MAX16067 can be programmed in the application circuit by taking into account the following points during circuit design:

- The MAX16067 needs to be powered from an intermediate voltage bus or auxiliary voltage supply so programming can occur even when the board's power supplies are off. This could also be achieved by using ORing diodes so that power can be provided through the programming connector.
- The SMBus or JTAG bus lines should not connect through a bus multiplexer powered from a voltage rail controlled by the MAX16067. If the device needs to be controlled by an on-board μP, consider connecting the μP to one bus (such as SMBus) and use the other bus for in-circuit programming.
- An unprogrammed MAX16067's EN\_OUT\_s go high impedance. Ensure that this does not cause undesired circuit behavior. If necessary, connect pulldown resistors to prevent power supplies from turning on.

**Table 31. RESET State, Flash State, and Reset Reason**

REGISTER ADDRESS	BIT RANGE	DESCRIPTION
r20h	[0]	Reset Output State 0 = RESET is low 1 = RESET is high
	[1]	1 = Flash memory is busy
	[2]	1 = Last reset asserted due to EN going low
	[3]	1 = Last reset asserted due to watchdog timeout
	[7:4]	Not used

# 6-Channel, Flash-Configurable System Manager with Nonvolatile Fault Registers

## Maintaining Power During a Fault Condition

Power to the MAX16067 must be maintained for a specific period of time to ensure a successful flash fault log operation during a fault that removes power to the circuit. Table 32 shows the amount of time required depends on the settings in the fault control register (r6Dh[1:0]).

Maintain power for shutdown during fault conditions in applications where the always-on power supply cannot be relied upon by placing a diode and a large capacitor between the voltage source,  $V_{IN}$ , and  $V_{CC}$  (Figure 15). The capacitor value depends on  $V_{IN}$  and the time delay required,  $t_{FAULT\_SAVE}$ . Use the following formula to calculate the capacitor size:

$$C = (t_{FAULT\_SAVE} \times I_{CC(MAX)}) / (V_{IN} - V_{DIODE} - V_{UVLO})$$

where the capacitance is in Farads and  $t_{FAULT\_SAVE}$  is in seconds,  $I_{CC(MAX)}$  is 14mA,  $V_{DIODE}$  is the voltage drop across the diode, and  $V_{UVLO}$  is 2.7V. For example, with a  $V_{IN}$  of 14V, a diode drop of 0.7V, and a  $t_{FAULT\_SAVE}$  of 153ms, the minimum required capacitance is 202 $\mu$ F.

## Driving High-Side MOSFET Switches

Up to three of the programmable outputs (EN\_OUT1, EN\_OUT2, EN\_OUT3) of the MAX16067 can be configured as charge-pump outputs to drive the gates of series-pass n-channel MOSFETS. When driving MOSFETS, these outputs act as simple power switches

to turn on the voltage supply rails. Approximate the slew rate, SR, using the following formula:

$$SR = I_{CP} / (C_{GATE} + C_{EXT})$$

where  $I_{CP}$  is the 6 $\mu$ A (typ) charge-pump source current,  $C_{GATE}$  is the gate capacitance of the MOSFET, and  $C_{EXT}$  is the capacitance connected from the gate to ground. If more than three series-pass MOSFETS are required for an application, additional series-pass p-channel MOSFETS can be connected to outputs configured as active-low open drain (Figure 16). Connect a pullup resistor from the gate to the source of the MOSFET, and ensure the absolute maximum ratings of the MAX16067 are not exceeded.

## Configuring the Device

An evaluation kit and a graphical user interface (GUI) are available to create a custom configuration for the device.

Refer to the MAX16067 Evaluation Kit for configuration.

## Cascading Multiple MAX16067s

Multiple MAX16067s can be cascaded to increase the number of rails controlled for sequencing and monitoring. There are many ways to cascade the devices depending on the desired behavior. In general, there are several techniques as follows:

- Configure a GPIO\_ on each device to be  $\overline{EXTFAULT}$  (open-drain). Externally wire them together with a single pullup resistor. Set register bits r72h[5] and r6Dh[2] to '1'

Table 32. Maximum Write Time

r6Dh[1:0] VALUE	DESCRIPTION	MAXIMUM WRITE TIME (ms)
00	Save flags and ADC readings	153
01	Save flags	102
10	Save ADC readings	153
11	Do not save anything	—

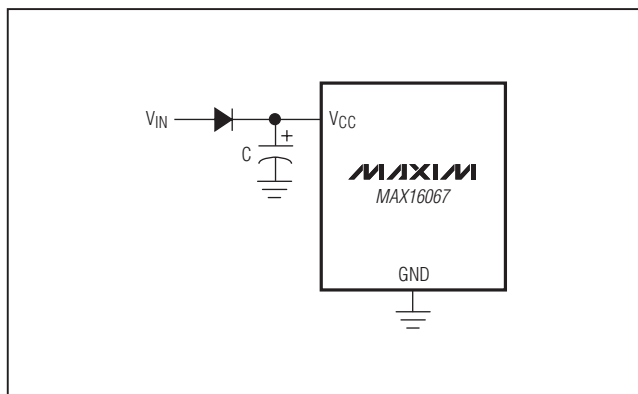

Figure 15. Power Circuit for Shutdown During Fault Conditions

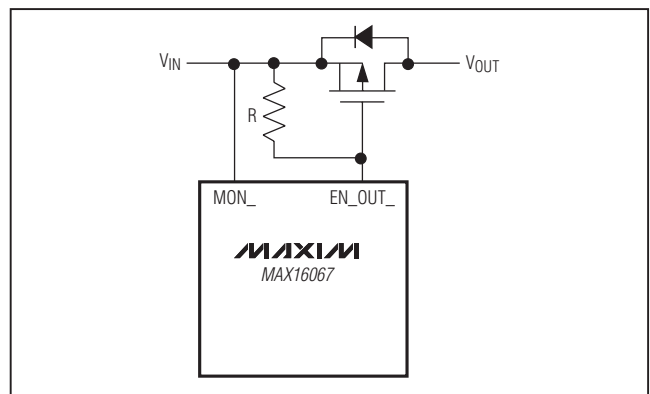

Figure 16. Connection for a p-Channel Series-Pass MOSFET

# 6-Channel, Flash-Configurable System Manager with Nonvolatile Fault Registers

so that all faults propagate between devices. If a critical fault occurs on one device, EXTFAULT asserts, triggering the nonvolatile fault logger in all cascaded devices and recording a snapshot of all system voltages.

- Connect open-drain RESET outputs together to obtain a master system reset signal.
- Connect all EN inputs together for a master enable signal. Since the internal timings of each cascaded device are not synchronized, EN\_OUT\_s placed in the same slot on different devices do not come up in the desired order even if the sequence delays are identical.
- Consider using an external  $\mu\text{P}$  to control the EN inputs or the software enable bits of cascaded devices, monitoring the RESET outputs as a power-good signal.
- For a large number of voltage rails, the MAX16067 can be cascaded hierarchically by using one master device's EN\_OUT\_s to control the EN inputs of several slave devices.

## Controlling Power Supplies Without Using the Sequencer

A  $\mu\text{P}$  can control power supplies manually without involving the sequencing slot system by controlling EN\_OUT\_s configured as GPIO. The output of a power supply controlled this way can be monitored using a MON\_ input configured as "monitoring only" (see the *Monitoring Inputs While Sequencing* section). To monitor the supply for critical faults, the  $\mu\text{P}$  will need to manually set the critical fault enable bit in r6Eh-r72h after turning on the EN\_OUT\_, and manually clearing the critical fault enable bit before turning off the EN\_OUT\_.

## Layout and Bypassing

Bypass DBP and ABP each with a 1 $\mu\text{F}$  ceramic capacitor to GND. Bypass VCC with a 10 $\mu\text{F}$  capacitor to ground. Avoid routing digital return currents through a sensitive analog area, such as an analog supply input return path or ABP's bypass capacitor ground connection. Use dedicated analog and digital ground planes. Connect the capacitors as close as possible to the device.

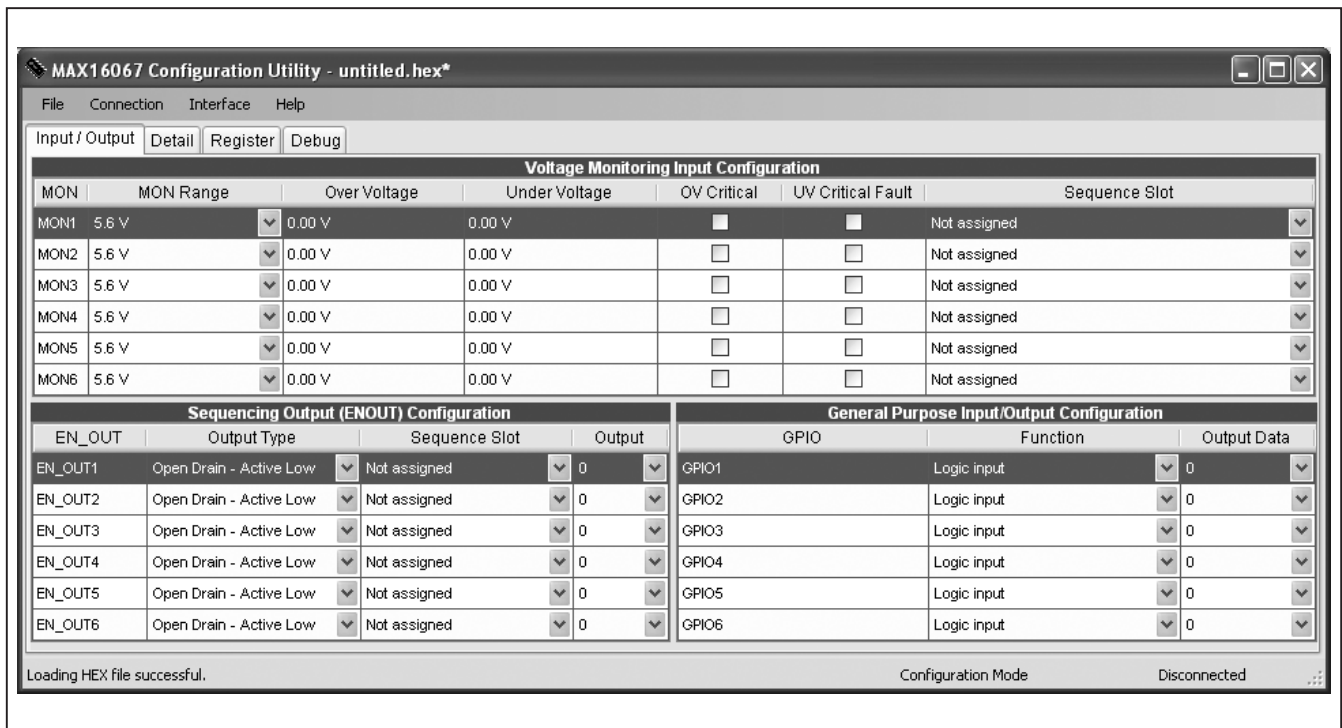

Figure 17. Graphical User Interface Screenshot

# 6-Channel, Flash-Configurable System Manager with Nonvolatile Fault Registers

## Register Map

FLASH ADDRESS	REGISTER ADDRESS	READ/ WRITE	DESCRIPTION
<b>ADC VALUES, FAULT REGISTERS, GPIOs AS INPUT PORTS—NOT IN FLASH</b>			
—	000	R	MON1 ADC output, MSBs
—	001	R	MON1 ADC output, LSBs
—	002	R	MON2 ADC output, MSBs
—	003	R	MON2 ADC output, LSBs
—	004	R	MON3 ADC output, MSBs
—	005	R	MON3 ADC output, LSBs
—	006	R	MON4 ADC output, MSBs
—	007	R	MON4 ADC output, LSBs
—	008	R	MON5 ADC output, MSBs
—	009	R	MON5 ADC output, LSBs
—	00A	R	MON6 ADC output, MSBs
—	00B	R	MON6 ADC output, LSBs
—	00C–01A	—	Reserved
—	01B	R/W	Fault register—failed line flags
—	01C	R/W	Fault register—failed line flags
—	01D	—	Reserved
—	01E	R	GPIO data in (read only)
—	01F	R	EN_OUT_ as GPIO data in (read only)
—	020	R/W	Flash status/reset output monitor
—	021	R	Current sequencer slot
<b>GPIO AND OUTPUT DEPENDENCIES/CONFIGURATIONS</b>			
230	030	R/W	EN_OUT_ configuration
231	031	R/W	EN_OUT_ configuration
232	032	—	Reserved
233	033	R/W	Charge-pump configuration bits
234	034	R/W	EN_OUT_ as GPIO data out
235	035	—	Reserved
236	036	R/W	FAULT dependencies
237	037	R/W	FAULT dependencies
238–23A	038–03A	—	Reserved
23B	03B	R/W	RESET output configuration
23C	03C	R/W	RESET output dependencies
23D	03D	R/W	RESET output dependencies
23E	03E	R/W	GPIO data out
23F	03F	R/W	GPIO configuration
240	040	R/W	GPIO configuration, ARANEN (ARA Enable)
241–242	041–042	—	Reserved

# 6-Channel, Flash-Configurable System Manager with Nonvolatile Fault Registers

## Register Map (continued)

MAX16067

FLASH ADDRESS	REGISTER ADDRESS	READ/ WRITE	DESCRIPTION
<b>ADC—CONVERSIONS</b>			
243	043	R/W	ADCs voltage ranges for MON_ monitoring
244	044	R/W	ADCs voltage ranges for MON_ monitoring
245–247	045–047	—	Reserved
<b>INPUT THRESHOLDS</b>			
248	048	—	Reserved
249	049	R/W	MON1 OV threshold
24A	04A	R/W	MON1 UV threshold
24B	04B	—	Reserved
24C	04C	R/W	MON2 OV threshold
24D	04D	R/W	MON2 UV threshold
24E	04E	—	Reserved
24F	04F	R/W	MON3 OV threshold
250	050	R/W	MON3 UV threshold
251	051	—	Reserved
252	052	R/W	MON4 OV threshold
253	053	R/W	MON4 UV threshold
254	054	—	Reserved
255	055	R/W	MON5 OV threshold
256	056	R/W	MON5 UV threshold
257	057	—	Reserved
258	058	R/W	MON6 OV threshold
259	059	R/W	MON6 UV threshold
25A–26C	05A–06C	—	Reserved
<b>FAULT SETUP</b>			
26D	06D	R/W	Save after EXTFAULT fault control
26E	06E	R/W	Faults causing store in flash
26F	06F	R/W	Faults causing store in flash
270	070	R/W	Faults causing store in flash
271	071	—	Reserved
272	072	R/W	EXTFAULT enable

## 6-Channel, Flash-Configurable System Manager with Nonvolatile Fault Registers

### Register Map (continued)

FLASH ADDRESS	REGISTER ADDRESS	READ/ WRITE	DESCRIPTION
<b>TIMEOUTS</b>			
273	073	R/W	Watchdog independent mode, margin enabled, soft RESET functionality
274	074	R/W	ADC fault deglitch/autoretry configuration
275	075	R/W	WDI toggle/fault timeout, reverse sequencing bit
276	076	R/W	WDRESET, WD timers
277	077	R/W	Sequence delay for Slot 0
278	078	R/W	Sequence delay for Slot 1
279	079	R/W	Sequence delay for Slot 2
27A	07A	R/W	Sequence delay for Slot 3
27B	07B	R/W	Sequence delay for Slot 4
27C	07C	R/W	Sequence delay for Slot 5
27D	07D	R/W	Sequence delay for Slot 6
<b>MISCELLANEOUS</b>			
27E	07E	R/W	Assign MON_ input from Slot 1 to Slot 6 or for monitoring
27F	07F	R/W	Assign MON_ input from Slot 1 to Slot 6 or for monitoring
280	080	R/W	Assign MON_ input from Slot 1 to Slot 6 or for monitoring
281–283	081–083	—	Reserved
284	084	R/W	Assign EN_OUT_ from Slot 1 to Slot 6
285	085	R/W	Assign EN_OUT_ from Slot 1 to Slot 6
286	086	R/W	Assign EN_OUT_ from Slot 1 to Slot 6
287–289	087–089	—	Reserved
28A	08A	R/W	Customer use (version)
28B	08B	R/W	PEC enable/SMBus address
28C	08C	R/W	Lock bits
28D	08D	R	Revision code
<b>USER FLASH</b>			
300	39F	R/W	User flash
3A0	3AF	—	Reserved
3B0	3FF	R/W	User flash

# 6-Channel, Flash-Configurable System Manager with Nonvolatile Fault Registers

## Typical Operating Circuit

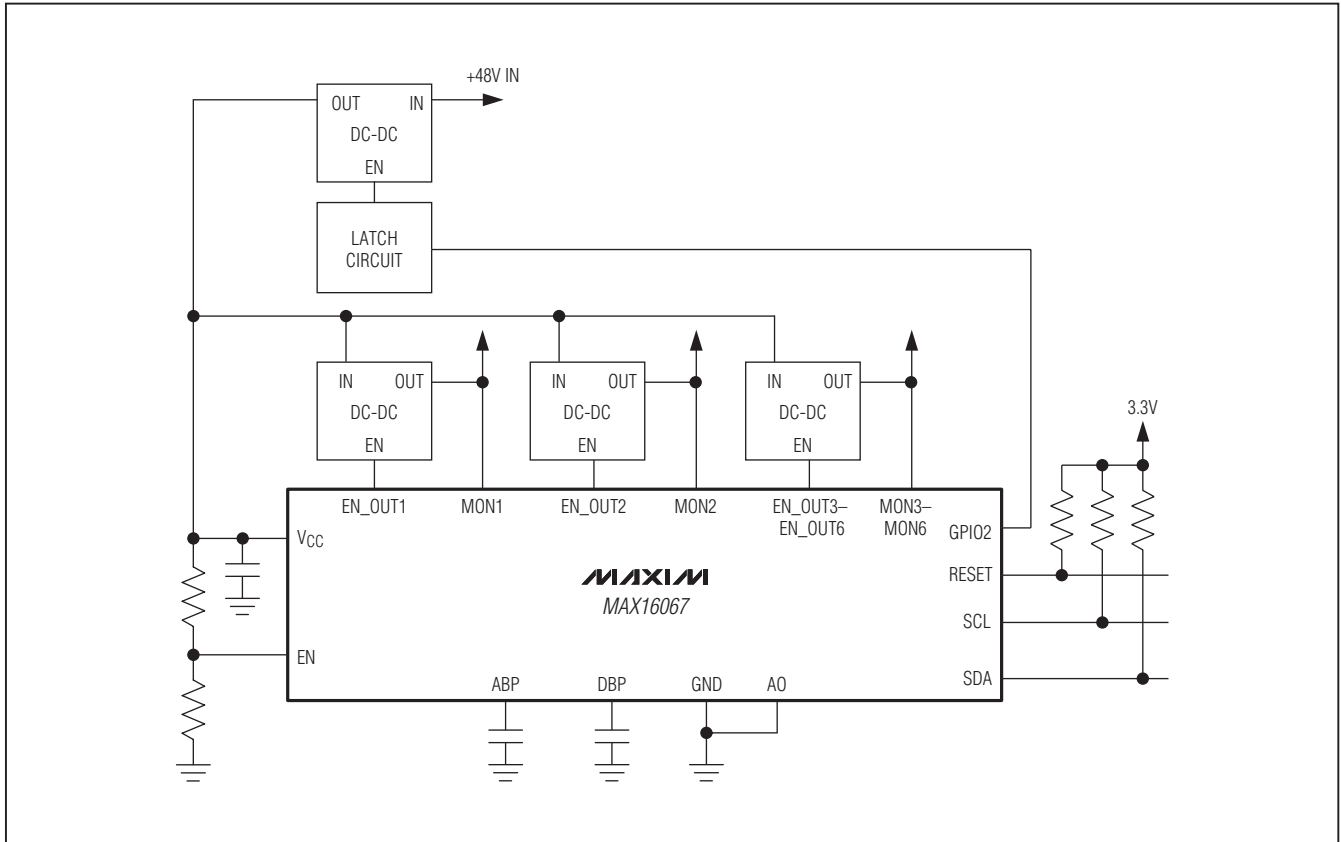

### Chip Information

PROCESS: BiCMOS

### Package Information

For the latest package outline information and land patterns, go to [www.maxim-ic.com/packages](http://www.maxim-ic.com/packages). Note that a "+", "#", or "-" in the package code indicates RoHS status only. Package drawings may show a different suffix character, but the drawing pertains to the package regardless of RoHS status.

PACKAGE TYPE	PACKAGE CODE	OUTLINE NO.	LAND PATTERN NO.
32 TQFN-EP	T3255+4	<a href="#">21-0140</a>	<a href="#">90-0012</a>

# 6-Channel, Flash-Configurable System Manager with Nonvolatile Fault Registers

## Revision History

REVISION NUMBER	REVISION DATE	DESCRIPTION	PAGES CHANGED
0	10/09	Initial release	—
1	2/10	Updated <i>Absolute Maximum Ratings</i> and Table 19	2, 23
2	6/10	Updated the <i>Applications</i> , <i>Absolute Maximum Ratings</i> , <i>Independent Watchdog Timer Operation</i> , <i>SMBus-Compatible Serial Interface</i> , <i>START and STOP Conditions</i> , <i>Read Byte</i> , <i>Block Write</i> , <i>Block Read</i> , <i>JTAG Serial Interface</i> , <i>Instruction Register</i> , and the <i>Restrictions When Writing to Flash</i> sections, <i>Figure 12</i> , <i>Table 30</i> , and the <i>Register Map table</i> .	1, 2, 28, 30, 34–37, 40, 41, 46

Maxim cannot assume responsibility for use of any circuitry other than circuitry entirely embodied in a Maxim product. No circuit patent licenses are implied. Maxim reserves the right to change the circuitry and specifications without notice at any time.

48 \_\_\_\_\_ **Maxim Integrated Products, 120 San Gabriel Drive, Sunnyvale, CA 94086 408-737-7600**



## X-ON Electronics

Largest Supplier of Electrical and Electronic Components

*Click to view similar products for [Supervisory Circuits](#) category:*

*Click to view products by [Maxim](#) manufacturer:*

Other Similar products are found below :

[CAT1161LI-25-G](#) [CAT853STBI-T3](#) [CAT1026LI-30-G](#) [CAT1320LI-25-G](#) [TC54VN2402EMB713](#) [MCP1316T-44NE/OT](#) [MCP1316MT-45GE/OT](#) [MCP1316MT-23LI/OT](#) [MAX8997EWW+](#) [MAX6725AKASYD3-LF-T](#) [DS1232L](#) [NCV302HSN45T1G](#) [PT7M6130NLTA3EX](#) [PT7M7811STBEX-2017](#) [S-1000N28-I4T1U](#) [CAT1161LI-28-G](#) [MCP1321T-29AE/OT](#) [MCP1319MT-47QE/OT](#) [S-1000N23-I4T1U](#) [S-1000N19-I4T1U](#) [CAT824UTDI-GT3](#) [TC54VC2502ECB713](#) [PT7M6133NLTA3EX](#) [PT7M6127NLTA3EX](#) [VDA2510NTA](#) [AP0809ES3-r](#) [HG811RM4/TR](#) [MD7030C](#) [MD7033C](#) [MD7019](#) [MD7020](#) [MD7021](#) [MD7023](#) [MD7024](#) [MD7027](#) [MD7030](#) [MD7033](#) [MD7035](#) [MD7036](#) [MD7039](#) [MD7040](#) [MD7044](#) [MD7050](#) [MD7015](#) [MD7022](#) [MD7028](#) [MD7031](#) [MD7042](#) [MD7043](#) [MD7047](#)