

## MAX16171

# Ideal Diode Controller with Reverse-Current Protection

### General Description

The MAX16171 is an ideal diode controller that protects the load against damaging automotive transients down to -42V and blocks reverse-current flow within 600ns. The MAX16171 operates over a wide supply voltage range of 4V to 57V and withstands input transients up to 76V. In light load applications, the device regulates the voltage drop across the external MOSFET to 20mV, allowing smooth, ring-free operation. At heavy load, the charge pump drives the gate of the external MOSFET into an enhanced mode of operation and significantly improves efficiency and power dissipation compared to traditionally used Schottky diodes.

The MAX16171 consumes only 1 $\mu$ A of current during shutdown mode ( $V_{EN} = GND$ ) to extend battery life while providing standby power to the load through the body diode of the external MOSFET. An internal 2.5M $\Omega$  resistor between GATE and SRC keeps the external MOSFET off when the input voltage drops below ground.

The MAX16171 is available in a tiny 2mm x 3mm x 0.75mm, 8-pin TDFN package with side-wettable flanks and operates over the -40°C to +125°C automotive temperature range.

### Applications

- Automotive Power Systems
- Network Telecom Power Systems
- Redundant Power Supplies
- RAID Systems
- Servers

### Benefits and Features

- -42V to +76V Protection Range
  - Relaxes TVS Diodes Requirements
- 4V to 57V Operating Range
  - Accommodates Wide Automotive Supply Rails
- 9V Gate Drive Voltage with Respect to SRC
  - Reduces MOSFET Power Dissipation
- Enable Input
  - Provides On-the-Fly System Control
- 1 $\mu$ A Shutdown Current
  - Extends Battery Life
- 600ns Reverse-Current Blocking Time with 10mV Overdrive
  - Extends System Operation Time During Power Interruption
- -40°C to +125°C Automotive Temperature Range
- 2mm x 3mm, Side-Wettable TDFN Package

[Ordering Information](#) appears at end of data sheet.

### Typical Application Circuit

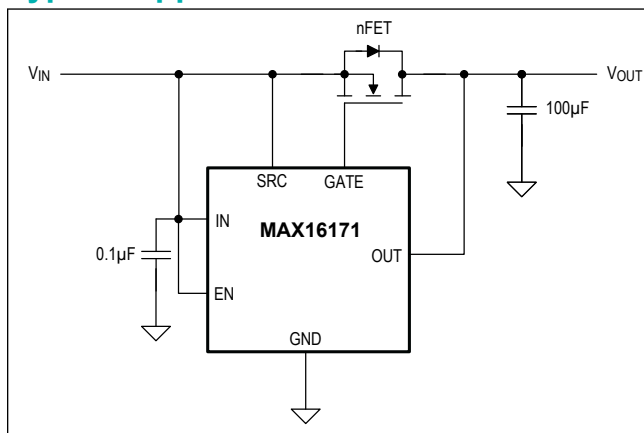

---

**TABLE OF CONTENTS**

---

General Description . . . . .	1
Applications . . . . .	1
Benefits and Features . . . . .	1
Typical Application Circuit . . . . .	1
Absolute Maximum Ratings . . . . .	4
Package Information . . . . .	4
8 TDFN-CU . . . . .	4
Electrical Characteristics . . . . .	4
Typical Operating Characteristics . . . . .	6
Pin Configuration . . . . .	7
Pin Descriptions . . . . .	8
Functional Diagram . . . . .	8
Block Diagram . . . . .	8
Detailed Description . . . . .	9
Input Voltage Range . . . . .	9
Ideal Diode Reverse-Current Protection . . . . .	9
Charge Pump . . . . .	9
EN Input . . . . .	9
Reverse-Voltage Protection . . . . .	10
Applications Information . . . . .	11
MOSFET Selection . . . . .	11
MOSFET Power Dissipation . . . . .	11
Extended Protection . . . . .	11
Redundant Power Supplies . . . . .	11
Layout Recommendations . . . . .	12
Typical Application Circuit . . . . .	13
Typical Operating Circuit . . . . .	13
Ordering Information . . . . .	13
Revision History . . . . .	14

---

**LIST OF FIGURES**

---

Figure 1. Reverse Voltage vs. GATE Response Timing Characteristics ..... 9

Figure 2. Extended Protection Scheme..... 11

Figure 3. Redundant Power Supply Circuit ..... 12

## Absolute Maximum Ratings

IN, SRC, GATE, EN to GND.....	-42V to +76V	Continuous Sink/Source Current (all pins).....	-100mA to +100mA
OUT to GND .....	-0.3V to +76V	Continuous Power Dissipation (Multilayer Board) (TDFN (T823Y+3C) T <sub>A</sub> = +70°C, derate 16.7mW/°C above +70°C).....	1333.3mW
IN to OUT .....	-76V to +76V	Operating Temperature Range .....	-40°C to +125°C
IN to SRC .....	-1V to +76V	Junction Temperature .....	+150°C
IN to GATE .....	-15V to +76V	Storage Temperature Range .....	-60°C to +150°C
IN to EN .....	-42V to +76V		
GATE to SRC .....	-0.3V to +15V		
SRC to EN .....	-42V to +76V		

Stresses beyond those listed under "Absolute Maximum Ratings" may cause permanent damage to the device. These are stress ratings only, and functional operation of the device at these or any other conditions beyond those indicated in the operational sections of the specifications is not implied. Exposure to absolute maximum rating conditions for extended periods may affect device reliability.

## Package Information

### 8 TDFN-CU

Package Code	T823Y+3C
Outline Number	<a href="#">21-100417</a>
Land Pattern Number	<a href="#">90-0091</a>
<b>Thermal Resistance, Single-Layer Board:</b>	
Junction to Ambient ( $\theta_{JA}$ )	
Junction to Case ( $\theta_{JC}$ )	
<b>Thermal Resistance, Four-Layer Board:</b>	
Junction to Ambient ( $\theta_{JA}$ )	60°C/W
Junction to Case ( $\theta_{JC}$ )	11°C/W

For the latest package outline information and land patterns (footprints), go to [www.maximintegrated.com/packages](http://www.maximintegrated.com/packages). Note that a "+", "#", or "-" in the package code indicates RoHS status only. Package drawings may show a different suffix character, but the drawing pertains to the package regardless of RoHS status.

Package thermal resistances were obtained using the method described in JEDEC specification JESD51-7, using a four-layer board. For detailed information on package thermal considerations, refer to [www.maximintegrated.com/thermal-tutorial](http://www.maximintegrated.com/thermal-tutorial).

## Electrical Characteristics

(V<sub>IN</sub> = 12V, C<sub>GATE-SRC</sub> = 3.5nF, T<sub>A</sub> = -40°C to +125°C, unless otherwise noted. Typical values are at T<sub>A</sub> = +25°C.)

PARAMETER	SYMBOL	CONDITIONS	MIN	TYP	MAX	UNITS
Input Voltage Range	V <sub>IN</sub>	Operating range	4		57	V
Input Protection Voltage Range	V <sub>IN</sub>		-42		+76	V
<b>INPUT SUPPLY CURRENT</b>						
Input Supply Current	I <sub>IN</sub>	V <sub>EN</sub> = high, V <sub>IN</sub> = V <sub>SRC</sub> = V <sub>OUT</sub> = 12V		150	190	μA
		V <sub>EN</sub> = high, V <sub>IN</sub> = V <sub>SCR</sub> = V <sub>OUT</sub> = 24V		150	200	
		V <sub>EN</sub> = high, V <sub>IN</sub> = V <sub>SRC</sub> , V <sub>OUT</sub> = 57V, T <sub>A</sub> = +125°C			250	
Shutdown Current		V <sub>EN</sub> = low, V <sub>IN</sub> = 12V		1	3	μA
Undervoltage Lockout	V <sub>UVLO</sub>	V <sub>IN</sub> rising		2.35	3.5	V

**Electrical Characteristics (continued)**(V<sub>IN</sub> = 12V, C<sub>GATE-SRC</sub> = 3.5nF, T<sub>A</sub> = -40°C to +125°C, unless otherwise noted. Typical values are at T<sub>A</sub> = +25°C.)

PARAMETER	SYMBOL	CONDITIONS	MIN	TYP	MAX	UNITS
Enable to Gate Startup Delay	t <sub>SU</sub>	EN (low to high) to GATE starting to go high (GATE rise to IN + 0.1V)		120		μs
<b>GATE OUTPUT VOLTAGE</b>						
GATE Output Voltage High above V <sub>SRC</sub>	V <sub>G5</sub>	V <sub>IN</sub> = V <sub>OUT</sub> = 4V, I <sub>GATE</sub> = -1μA	3.5	5.4	12	V
		V <sub>IN</sub> = V <sub>OUT</sub> = 12V to 57V, I <sub>GATE</sub> = -1μA	6	9	12	
Source-to-Drain Regulation Voltage	V <sub>SD</sub>		10	20	35	mV
GATE Pulldown Current	I <sub>GPD</sub>	V <sub>IN</sub> = 12V, V <sub>GATE</sub> - V <sub>SCR</sub> = 8V		400		mA
GATE Pullup Current	I <sub>GPU</sub>	EN goes from low to high, GATE short to SRC, measure charge current from GATE pin	8	15		μA
EN Logic-High Input Voltage	V <sub>IH</sub>		1.4			V
EN Logic Low Input Voltage	V <sub>IL</sub>				0.4	V
EN Input Pull Down Current	I <sub>EPD</sub>			1		μA
OUT Input Current	I <sub>OUT</sub>	EN = high, IN/SRC = OUT = 12V		4		μA
<b>REVERSE-CURRENT THRESHOLD</b>						
Reverse-Current Threshold	V <sub>REV_TH</sub>		4	10	16	mV
Reverse-Current Recover Threshold		V <sub>IN</sub> - V <sub>OUT</sub> = 40mV		40		mV
Reverse-Current Blocking Response Time	t <sub>REV</sub>	(V <sub>OUT</sub> - V <sub>SCR</sub> ) = -0.1V to (V <sub>REV_TH</sub> + 0.01V), I <sub>GATE_SINK</sub> = 100μA		0.6	2.1	μs

Typical Operating Characteristics

( $V_{IN} = V_{SCR} = 12V$ ,  $T_A = T_{MIN}$  to  $T_{MAX}$  unless otherwise noted.)

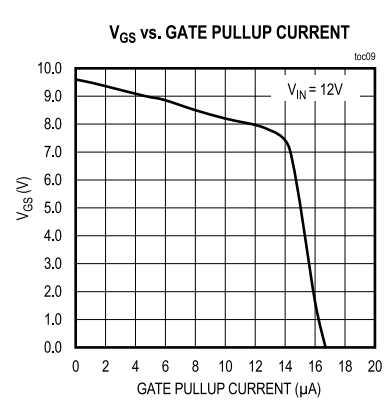
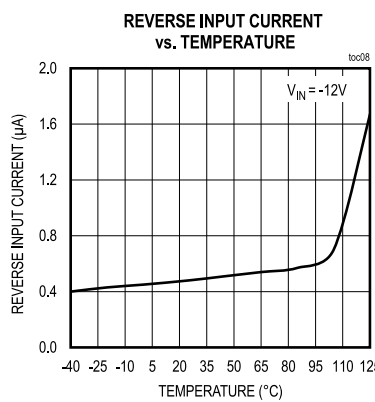
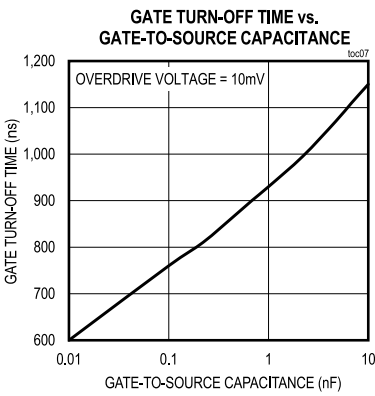
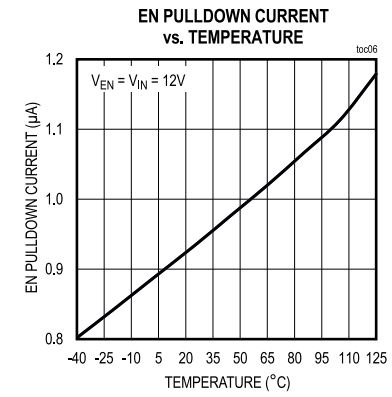
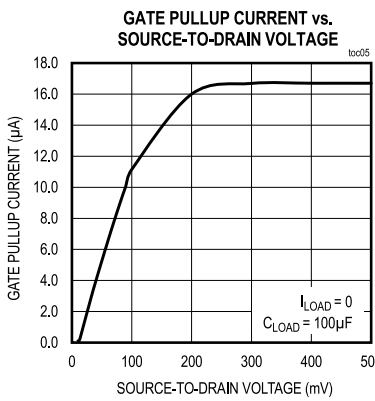
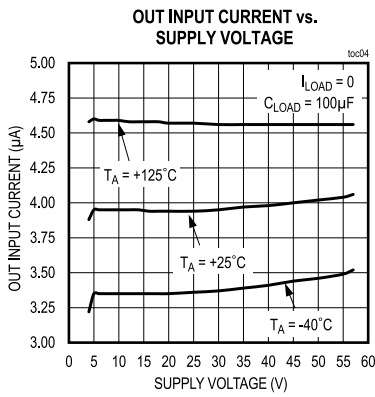
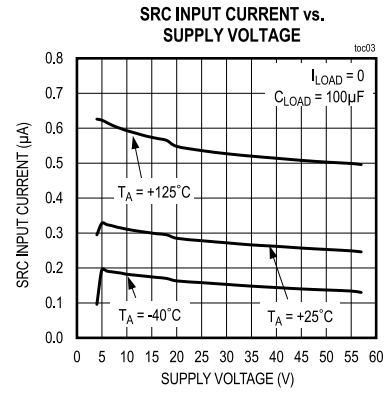
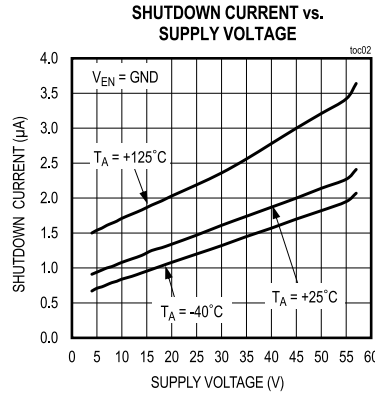
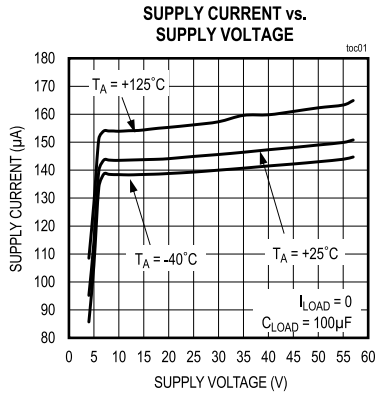

Typical Operating Characteristics (continued)

( $V_{IN} = V_{SCR} = 12V$ ,  $T_A = T_{MIN}$  to  $T_{MAX}$  unless otherwise noted.)

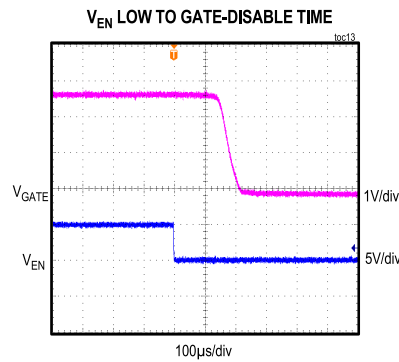
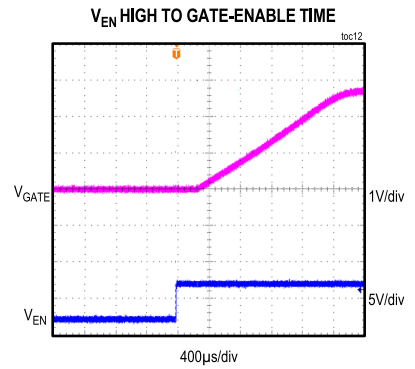
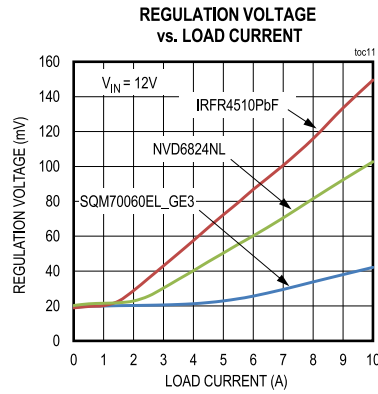
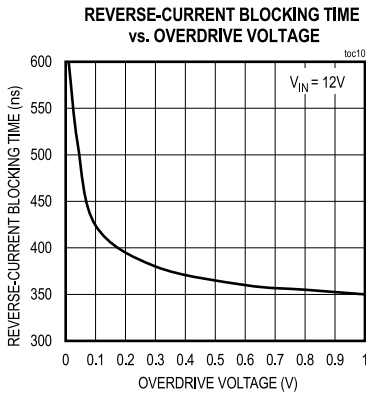

Pin Configuration

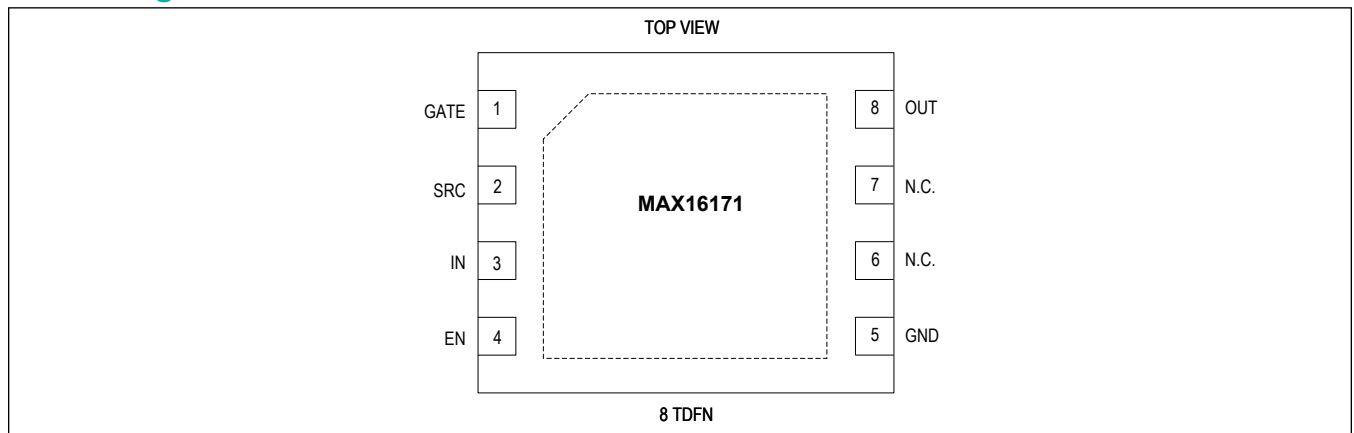

Pin Descriptions

PIN	NAME	FUNCTION
1	GATE	Gate-Driver Output. Connect GATE to the gate of the external n-channel MOSFET (nFET). GATE shorts to SRC during reverse-current conditions and when EN is forced low.
2	SRC	Source Input. SRC is the return path of the gate during fault conditions or when EN is pulled low. Connect SRC as close as possible to the source input of the of the external MOSFET.
3	IN	Supply Input. Bypass IN with 0.1 $\mu$ F capacitor to ground.
4	EN	Enable Input. Drive EN low to place the MAX16171 in shutdown mode. EN has an internal pulldown to ground. Drive EN high for normal operation.
5	GND	Ground
6, 7	N.C.	No Connect. Connect to ground for proper operation.
8	OUT	Output Sense Input. Connect OUT to the drain of the nFET.

Functional Diagram

Block Diagram

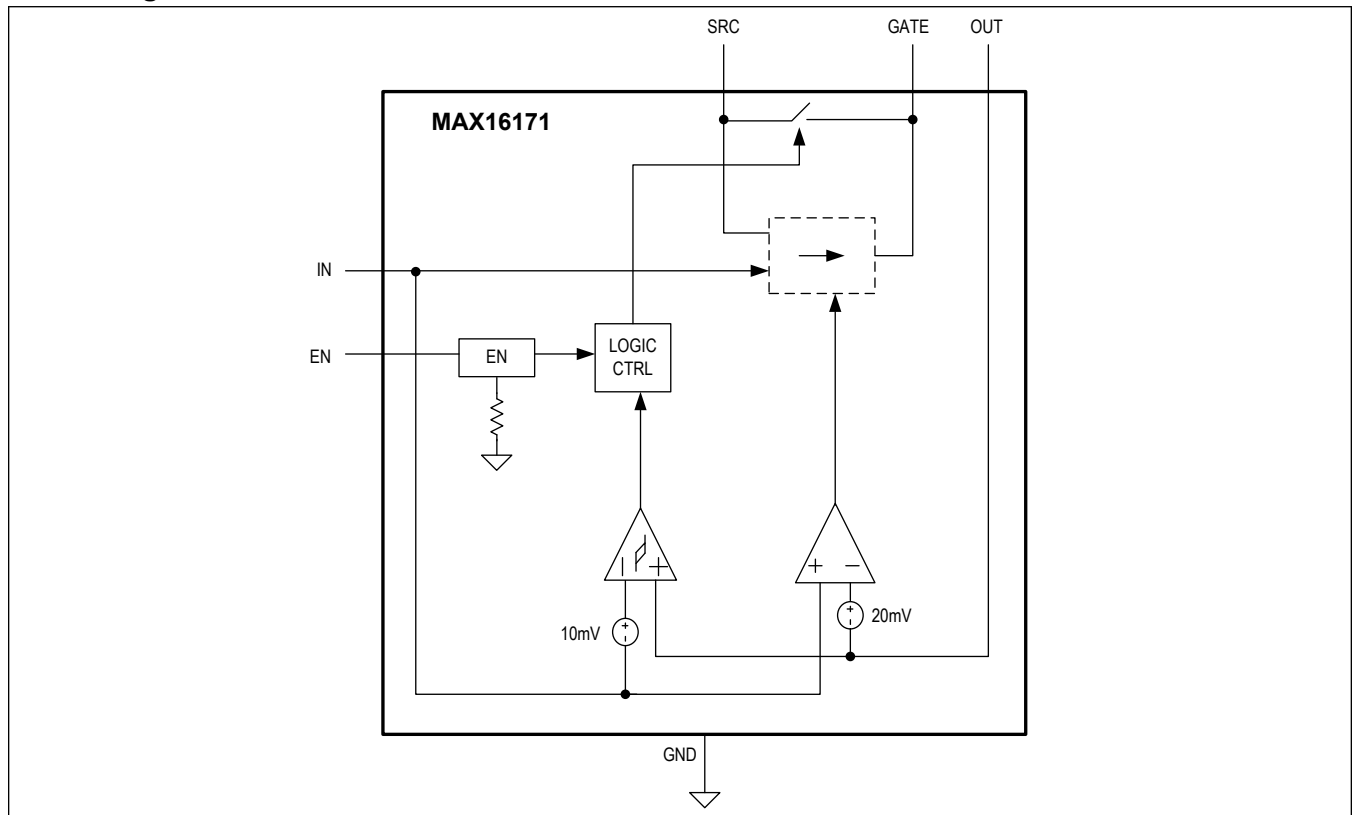



## Detailed Description

The MAX16171 is a high-voltage, ideal diode controller that provides system protection against reverse voltage, reverse-current flow, and destructive automotive transient voltages. The MAX16171's charge pump is designed to regulate the forward-voltage drop across the MOSFET to 20mV in light load applications. At higher load currents, the charge pump provides the necessary gate drive to fully enhance the external MOSFET to minimize power dissipation. A fast-acting comparator allows the MAX16171 to disable the gate drive within 600ns, thus preventing reverse-current flow when the input falls below the output. The MAX16171 consumes only 1 $\mu$ A (typ) of current in shutdown mode, which helps extend battery life and enables the system to operate in standby mode.

## Input Voltage Range

The MAX16171 operates over a wide supply voltage range of 4V to 57V while protecting itself against an input-transient range of -42V to +76V. The MAX16171's wide protection range helps minimize power dissipation in TVS diodes used for extended protection at the input. When the input transient exceeds the maximum operating voltage of 57V, the MAX16171 disables the gate to prevent gate voltage from exceeding its absolute maximum ratings.

## Ideal Diode Reverse-Current Protection

The MAX16171 triggers reverse-voltage protection to prevent reverse-current flow 600ns after the input falls 10mV below the reverse-voltage threshold level. See [Electrical Characteristics](#) for more detail. Disabling the gate drive in such a short time helps prevent reverse-current flow from the holdup capacitor at the output into the source, thus preventing damage to the battery and effectively increasing system runtime. See [Figure 1](#) for more detail.

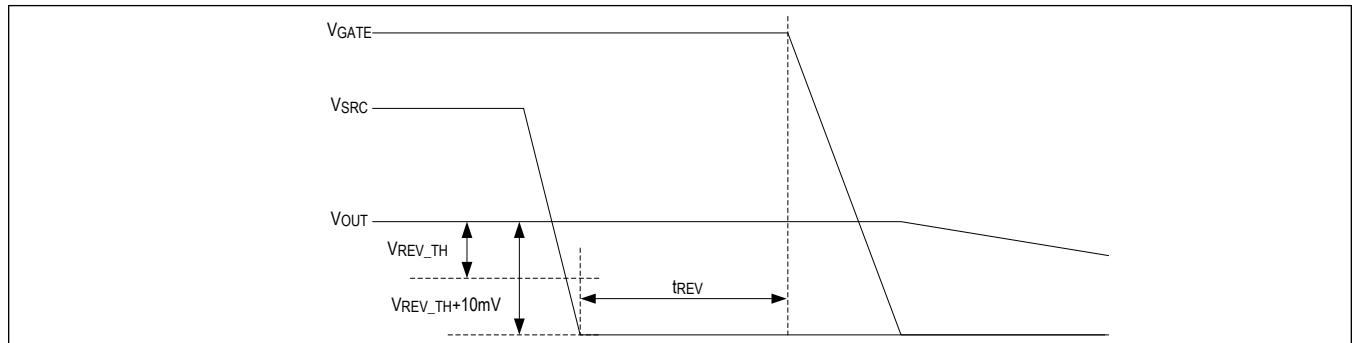

Figure 1. Reverse Voltage vs. GATE Response Timing Characteristics

## Charge Pump

The MAX16171 uses a charge pump to generate the gate drive with respect to SRC voltage. Under heavy load conditions, the charge pump generates up to a 9V gate drive to ensure the MOSFET is operated in enhanced mode and minimizes power dissipation. During light load conditions, the MAX16171 regulates the gate drive to maintain a 20mV drop between the source and the drain of the MOSFET. In the event of a fault condition, the device disables the charge pump and an internal switch shorts GATE to SRC with 400mA (typ) pulldown current.

## EN Input

A logic input (EN) enables/disables the gate drive of the MAX16171 during normal operation. The MAX16171 enables the gate in 200 $\mu$ s (typ) when EN is forced high. When EN is forced low, the MAX16171 enters shutdown mode and GATE is shorted to SRC by an internal switch. During shutdown mode, the power flows from the source to the load through the body diode of the nFET, but the shutdown current of the part remains at a low 1 $\mu$ A (typ). This helps support low-power system operation while extending battery life due to the MAX16171 low shutdown current consumption. EN has an internal pulldown resistor to ground and cannot be left floating for normal operation.

**Reverse-Voltage Protection**

The MAX16171 integrates reverse-voltage protection, thus preventing damage to the downstream circuitry caused by battery reversal or negative transients. The MAX16171 withstands a reverse voltage to -42V without damage to itself or the load. During a reverse-voltage condition, an internal 2.5M $\Omega$  resistor between GATE and SRC pulls GATE to SCR to keep the MOSFET off and isolate the load from the source.

## Applications Information

### MOSFET Selection

MOSFET selection is critical to designing a proper protection circuit. Several factors must be considered: gate capacitance, maximum drain-to-source voltage rating, on-resistance ( $R_{DS(ON)}$ ), peak power dissipation capability, and the average power dissipation limit. Select the drain-to-source voltage so that the MOSFET can handle the highest voltage that might be applied to the circuit. Gate capacitance is not as critical, but it does determine the length of turn-on and turn-off times. MOSFETs with more gate capacitance tend to respond more slowly.

### MOSFET Power Dissipation

Since all load current goes through the external MOSFET, the  $R_{DS(ON)}$  must be low enough to limit the MOSFET power dissipation during normal operation. Power dissipation during normal operation can be calculated using this formula:

$$P = (I_{LOAD})^2 \times R_{DS(ON)}$$

where  $P$  is the power dissipated in each MOSFET and  $I_{LOAD}$  is the average load current.

### Extended Protection

The MAX16171 can tolerate -42V to +76V at its input. In cases where the input voltage is expected to exceed the MAX16171's protection range, external TVS diodes can be used to clamp input transients. [Figure 2](#) shows the connection scheme for the TVS diode at the input of the MAX16171. In the figure, D1 clamps positive voltage excursions and D2 clamps negative voltage excursions. Select the TVS voltage ratings so that the worst-case voltages do not exceed the ratings of the part. In addition, ensure that the selected TVS diodes have the capability to absorb the input transient energy.

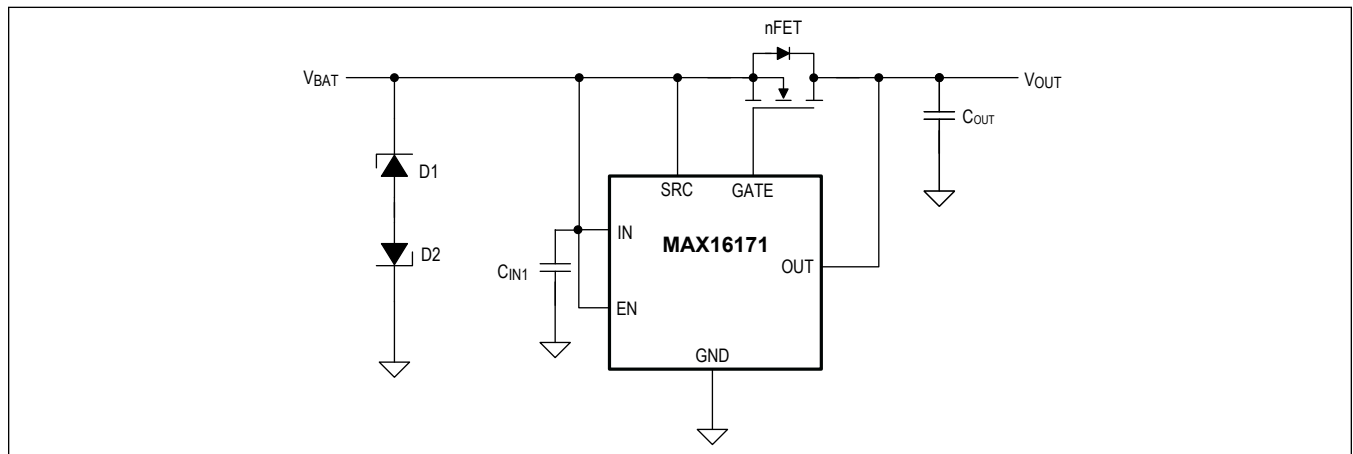

Figure 2. Extended Protection Scheme

### Redundant Power Supplies

Many high-reliability applications require a redundant power-supply scheme to ensure the availability of power at all times. When one of the supplies is lost, the other supply must take over to keep the system operating without interruption. The MAX16171 supports redundant power-supply applications. See [Figure 3](#) for an application circuit example. When one of the input rails falls below the output, the MAX16171 stops regulating the voltage across the external MOSFET and shorts GATE to SRC to prevent reverse-current flow and allow the secondary power source to support the load.

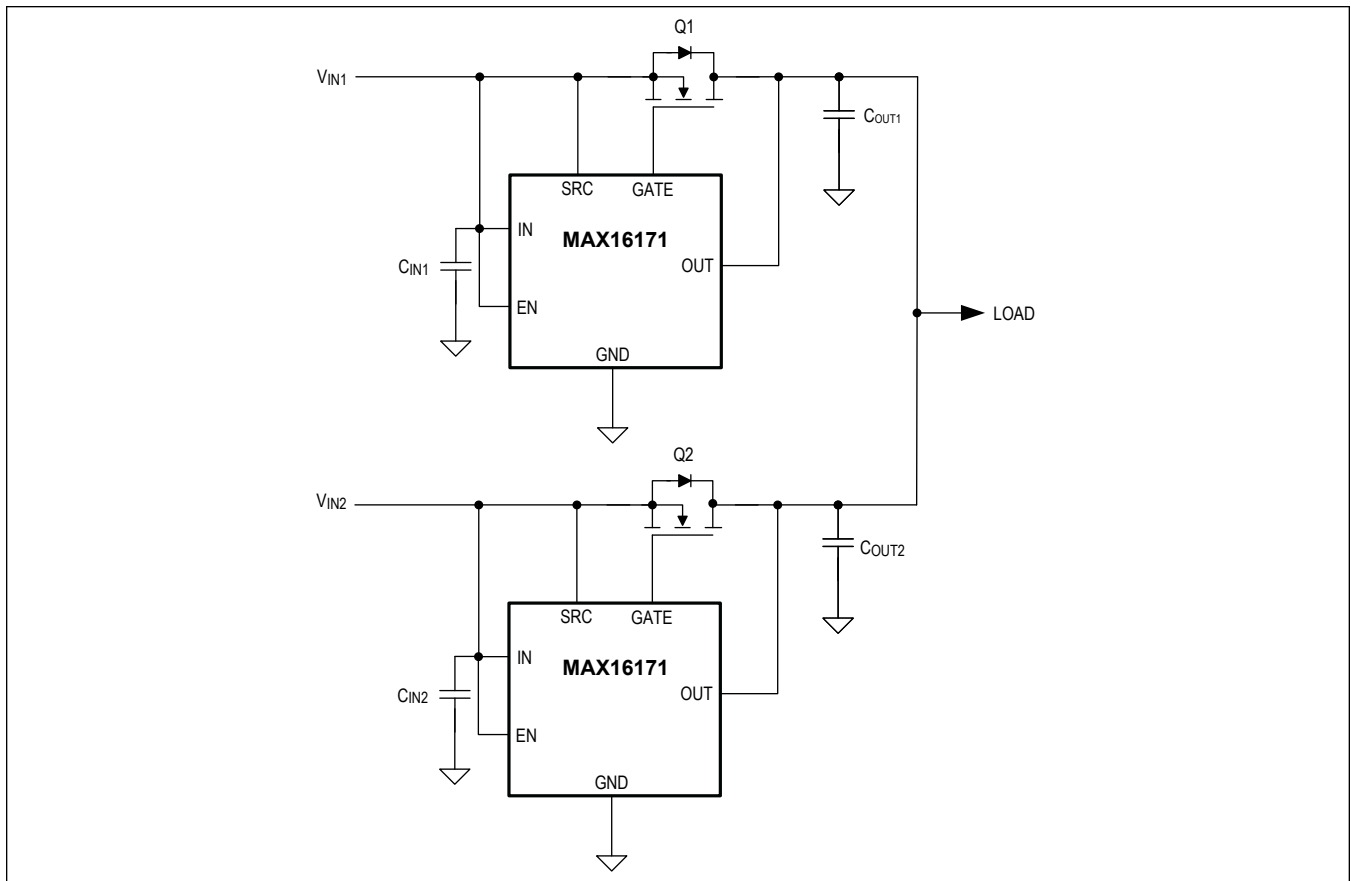

Figure 3. Redundant Power Supply Circuit

### Layout Recommendations

To optimize device operation, use the following recommendations:

- Bypass the input voltage (IN) to ground with at least a  $0.1\mu\text{F}$  capacitor connected as close as possible between the input and ground pins.
- Minimize trace length and impedance connecting SRC and OUT to the source and drain pins of the external MOSFET, respectively.
- Connect GATE to the gate of the external MOSFET directly with no vias in between.
- Minimize stray capacitance between GATE and the gate of the MOSFET to minimize gate response time fault conditions.
- For high-current applications, minimize IR losses and heat dissipation by mounting the appropriate heat sink, air-flow, and low-resistance traces between the source and load.
- Connect the exposed pad to the ground pin of the IC and do not use the exposed pad as the only ground connection.

## Typical Application Circuit

### Typical Operating Circuit

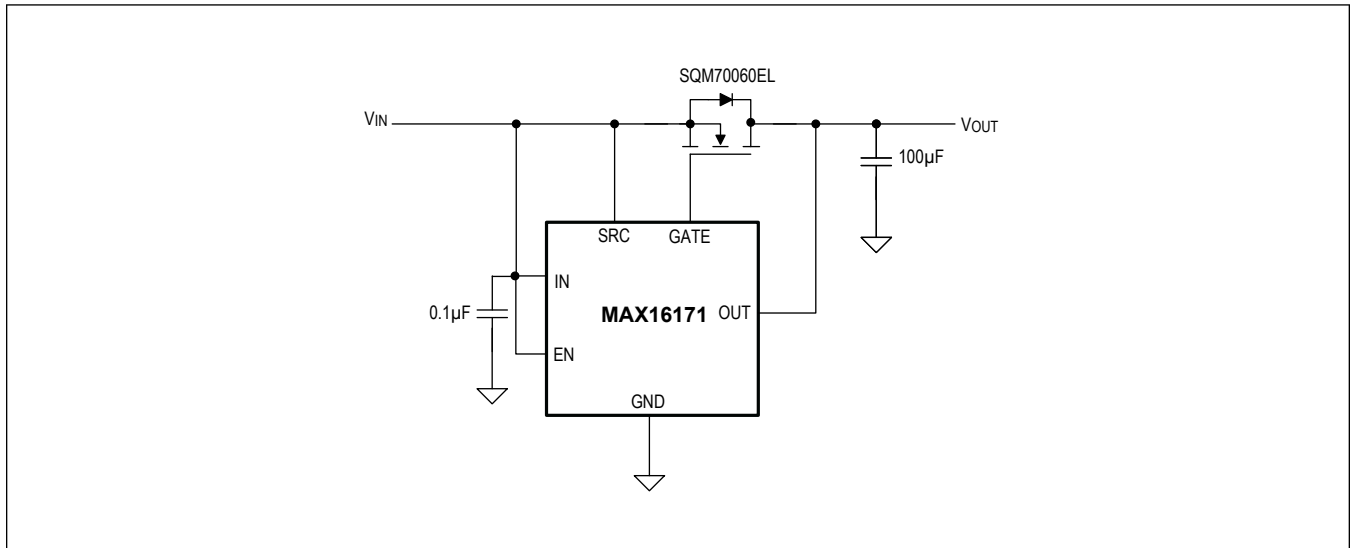

## Ordering Information

PART NUMBER	TEMP RANGE	PIN-PACKAGE
MAX16171ATA/VY+T	-40°C to +125°C	8 TDFN-CU
MAX16171ATA+T	-40°C to +125°C	8 TDFN-CU

*N* denotes automotive grade.

*Y* denotes side-wettable package.

*+* Denotes a lead(Pb)-free/RoHS-compliant package.

*T* = Tape and reel.

## Revision History

REVISION NUMBER	REVISION DATE	DESCRIPTION	PAGES CHANGED
0	9/20	Release for intro	—
1	4/21	Updated <i>Typical Operating Characteristics</i> , <i>Pin Descriptions</i> , <i>Block Diagram</i> , <i>Detailed Description</i> , and <i>Ordering Information</i> table	6–9, 13
2	5/21	Updated <i>Ordering Information</i> table	13

For pricing, delivery, and ordering information, please visit Maxim Integrated's online storefront at <https://www.maximintegrated.com/en/storefront/storefront.html>.

*Maxim Integrated cannot assume responsibility for use of any circuitry other than circuitry entirely embodied in a Maxim Integrated product. No circuit patent licenses are implied. Maxim Integrated reserves the right to change the circuitry and specifications without notice at any time. The parametric values (min and max limits) shown in the Electrical Characteristics table are guaranteed. Other parametric values quoted in this data sheet are provided for guidance.*

## X-ON Electronics

Largest Supplier of Electrical and Electronic Components

*Click to view similar products for [Power Management Specialised - PMIC category](#):*

*Click to view products by [Maxim manufacturer](#):*

Other Similar products are found below :

[LV5686PVC-XH](#) [FAN7710VN](#) [NCP391FCALT2G](#) [SLG7NT4081VTR](#) [SLG7NT4192VTR](#) [AP4313UKTR-G1](#) [AS3729B-BWLM](#)  
[MB39C831QN-G-EFE2](#) [LV56841PVD-XH](#) [AP4306BUKTR-G1](#) [MIC5164YMM](#) [PT8A3252WE](#) [NCP392CSFCCT1G](#) [PT8A3284WE](#)  
[PI3VST01ZEEX](#) [PI5USB1458AZAEX](#) [PI5USB1468AZAEX](#) [MCP16502TAC-E/S8B](#) [MCP16502TAE-E/S8B](#) [MCP16502TAA-E/S8B](#)  
[MCP16502TAB-E/S8B](#) [TCKE712BNL,RF](#) [ISL91211AIKZT7AR5874](#) [ISL91211BIKZT7AR5878](#) [MCP16501TC-E/RMB](#) [ISL91212AIIZ-](#)  
[TR5770](#) [ISL91212BIIZ-TR5775](#) [CPX200D](#) [AX-3005D-3](#) [TP-1303](#) [TP-1305](#) [TP-1603](#) [TP-2305](#) [TP-30102](#) [TP-4503N](#) [MIC5167YML-TR](#)  
[LPTM21-1AFTG237C](#) [LR745N8-G](#) [MPS-3003L-3](#) [MPS-3005D](#) [SPD-3606](#) [STLUX383A](#) [TP-60052](#) [ADN8834ACBZ-R7](#) [LM26480SQ-](#)  
[AA/NOPB](#) [LM81BIMTX-3/NOPB](#) [LM81CIMT-3/NOPB](#) [MIC5166YML-TR](#) [GPE-4323](#) [GPS-2303](#)