



MAX1678 Evaluation Kit

Evaluates: MAX1678

General Description

The MAX1678 evaluation kit (EV kit) provides a regulated 3.3V output while operating on input voltages as low as 0.7V with guaranteed start-up at 0.87V. The input source can be a 1 or 2-cell battery or a DC supply. Efficiency is typically 90% with output loads up to 100mA.

The kit uses surface-mount components and is fully assembled and tested for quick evaluation. Jumpers are provided for selecting an adjustable output voltage and for shutdown control.

Component List

DESIGNATION	QTY	DESCRIPTION
C1, C2	2	10 μ F, 10V ceramic capacitor Taiyo Yuden LMK325BJ106MN, TDK C3225X5R1A106M
L1	1	47 μ H, 240mA power inductor Coilcraft DS1608C-473 Sumida CD43-470 Murata LQH4N470K
J1	1	3-pin jumper
J2	1	2-pin jumper
R1, R4	2	1M Ω , 1% resistors
R2, R3	2	Open
R5	1	100k Ω , 5% resistor
U1	1	MAX1678EUA
None	2	Shunts
None	1	MAX1678 EV kit PC board
None	1	MAX1678 data sheet

Component Suppliers

SUPPLIER	PHONE	FAX
Coilcraft	847-639-6400	847-639-1469
Coiltronics	561-241-7876	561-241-9339
Murata	814-237-1431	814-238-0490
Sumida	847-956-0666	847-956-0702
Taiyo Yuden	408-573-4150	408-573-4159
TDK	847-390-4373	847-390-4428

Features

- ◆ 0.87V to V_{OUT} Input Range
- ◆ Synchronous Rectified—No External Diode Required
- ◆ 3.3V Output Voltage (or Adjustable)
- ◆ 100mA Output
- ◆ 90% Efficiency
- ◆ 2 μ A Shutdown Current
- ◆ Small Surface-Mount Components
- ◆ Inductor Damping Switch Suppresses EMI

Ordering Information

PART	TEMP. RANGE	IC PACKAGE
MAX1678EVKIT	0°C to +70°C	8 μ MAX

Quick Start

The MAX1678 EV kit is shipped fully assembled and tested. Follow these steps to verify board operation. **Do not turn on the power supply until all connections are completed.**

- 1) Verify that the shunts are positioned on the jumpers as listed in Table 2 for a 3.3V output.
- 2) Connect a +0.87V to +3.3V supply voltage to the VIN pad. Connect ground to the GND pad. **Note:** once started, the input voltage may drop as low as 0.7V if the output current is less than 10mA.
- 3) Connect a voltmeter and the load (if any) to the VOUT pad.
- 4) Turn on the power and verify that the output voltage is +3.3V.

MAX1678 Evaluation Kit

Detailed Description

Jumper Selections

Two jumpers on the PC board allow selection of several configurations. Table 1 lists the jumper functions. Table 2 lists the jumper positions when setting the board for 3.3V operation.

Component Selection

The final circuit performance is determined by the quality of the components surrounding the MAX1678. The input and output capacitors must have low equivalent-series-resistance (ESR) to handle the high peak currents found in switching regulators. Low ESR is especially critical in low-voltage circuits to reduce the output ripple. Ceramic capacitors are supplied on the MAX1678 EV kit because of their small size and low ESR in the value range needed for the circuit.

Table 1. Jumper Functions

JUMPER	SHUNT POSITION	PIN CONNECTION	MAX1678 OPERATION
J1	1 & 2	$\overline{\text{SHDN}}$ connected to BATT	The MAX1678 is enabled.
J1	2 & 3	$\overline{\text{SHDN}}$ connected to GND	The MAX1678 is disabled.
J1	Open	$\overline{\text{SHDN}}$ not controlled by the board	$\overline{\text{SHDN}}$ must be driven by a signal connected to the $\overline{\text{SHDN}}$ pad.
J2	Shorted	FB pin connected to GND	VOUT is preset to 3.3V.
J2	Open	FB pin connected to the resistor-divider	A resistor must be installed in R3 to set the output voltage. See the MAX1678 data sheet for more information.

Table 2. Jumper Positions for Normal 3.3V Operation

JUMPER	SHUNT POSITION	PIN CONNECTION	MAX1678 OPERATION
J1	1 & 2	$\overline{\text{SHDN}}$ pin connected to BATT	The MAX1678 is enabled.
J2	Shorted	FB pin connected to GND	VOUT is preset to 3.3V.

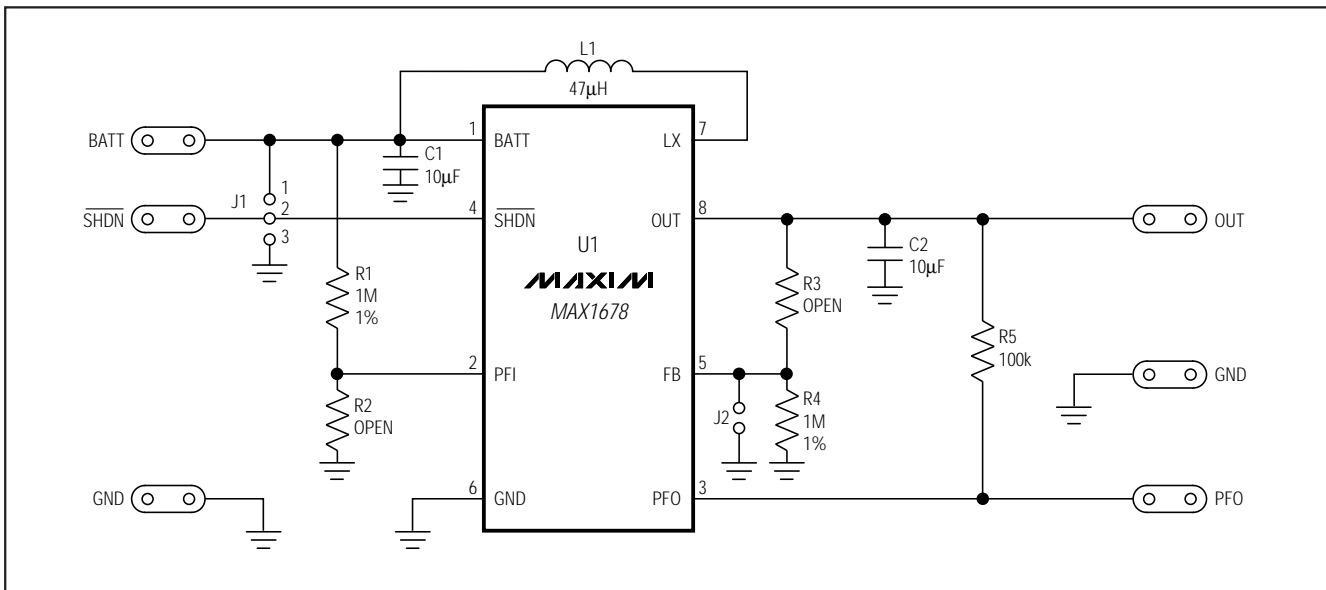

Figure 1. MAX1678 EV Kit Schematic

MAX1678 Evaluation Kit

Evaluates: MAX1678

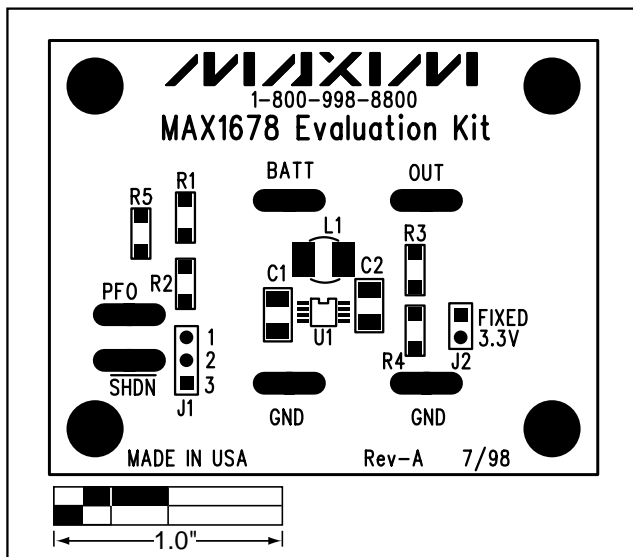

Figure 2. Component Placement Guide—Component Side

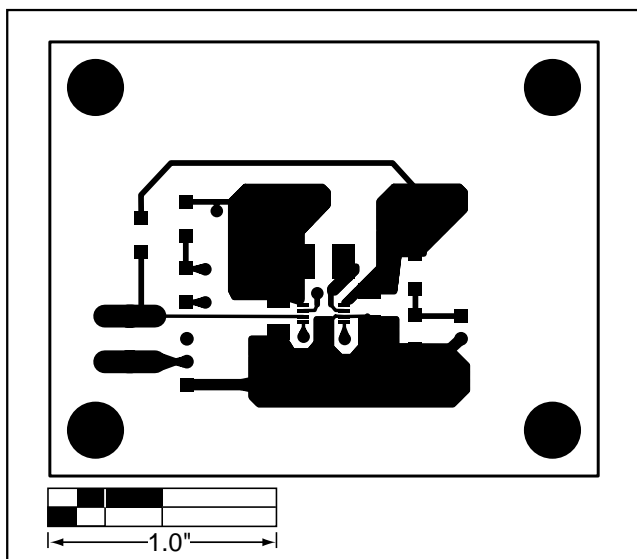

Figure 3. PC Board Layout—Component Side

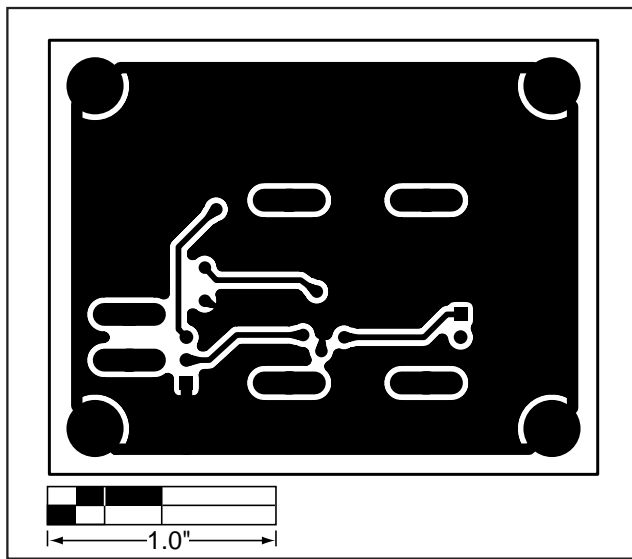

Figure 4. PC Board Layout—Solder Side

MAX1678 Evaluation Kit

Evaluates: MAX1678

NOTES

Maxim cannot assume responsibility for use of any circuitry other than circuitry entirely embodied in a Maxim product. No circuit patent licenses are implied. Maxim reserves the right to change the circuitry and specifications without notice at any time.

4 _____ Maxim Integrated Products, 120 San Gabriel Drive, Sunnyvale, CA 94086 408-737-7600

X-ON Electronics

Largest Supplier of Electrical and Electronic Components

Click to view similar products for [Power Management IC Development Tools](#) category:

Click to view products by [Maxim](#) manufacturer:

Other Similar products are found below :

[EVB-EP5348UI](#) [MIC23451-AAAYFL EV](#) [MIC5281YMME EV](#) [124352-HMC860LP3E](#) [DA9063-EVAL](#) [ADP122-3.3-EVALZ](#) [ADP130-0.8-EVALZ](#) [ADP130-1.8-EVALZ](#) [ADP1740-1.5-EVALZ](#) [ADP1870-0.3-EVALZ](#) [ADP1874-0.3-EVALZ](#) [ADP199CB-EVALZ](#) [ADP2102-1.25-EVALZ](#) [ADP2102-1.875EVALZ](#) [ADP2102-1.8-EVALZ](#) [ADP2102-2-EVALZ](#) [ADP2102-3-EVALZ](#) [ADP2102-4-EVALZ](#) [AS3606-DB](#) [BQ25010EVM](#) [BQ3055EVM](#) [ISLUSBI2CKIT1Z](#) [LP38512TS-1.8EV](#) [EVAL-ADM1186-1MBZ](#) [EVAL-ADM1186-2MBZ](#) [ADP122UJZ-REDYKIT](#) [ADP166Z-REDYKIT](#) [ADP170-1.8-EVALZ](#) [ADP171-EVALZ](#) [ADP1853-EVALZ](#) [ADP1873-0.3-EVALZ](#) [ADP198CP-EVALZ](#) [ADP2102-1.0-EVALZ](#) [ADP2102-1-EVALZ](#) [ADP2107-1.8-EVALZ](#) [ADP5020CP-EVALZ](#) [CC-ACC-DBMX-51](#) [ATPL230A-EK](#) [MIC23250-S4YMT EV](#) [MIC26603YJL EV](#) [MIC33050-SYHL EV](#) [TPS60100EVM-131](#) [TPS65010EVM-230](#) [TPS71933-28EVM-213](#) [TPS72728YFFEVM-407](#) [TPS79318YEQEVM](#) [UCC28810EVM-002](#) [XILINXPWR-083](#) [LMR22007YMINI-EVM](#) [LP38501ATJ-EV](#)