

MAXIM

MAX1688 Evaluation Kit

General Description

The MAX1688 evaluation kit (EV kit) is a boost switching regulator for one Li-Ion cell or three NiCd/NiMH cells in battery-powered systems. The EV kit accepts a positive input between 2.7V and 6V and converts it to a 5V output. It can easily deliver the current burst required for cell-phone power amplifier systems. The MAX1688 reduces battery surge current by slowly charging a reservoir capacitor, which supplies the necessary peak energy for the current burst. As a result, the peak battery input current is limited, thereby minimizing the battery voltage sag and transient dips. The EV kit operates at 600kHz, allowing the use of small external components.

The MAX1688 EV kit provides low quiescent current and high efficiency for maximum battery life. An internal synchronous rectifier is used to provide over 90% conversion efficiency. This EV kit is a fully assembled and tested surface-mount circuit board. The MAX1688 EV kit can also be used to evaluate the MAX1687.

Component List

DESIGNATION	QTY	DESCRIPTION
C1	1	47 μ F, 16V tantalum capacitor AVX TPSC476M016R0350 or Sprague 595D476X0016C2T
C2	1	0.1 μ F ceramic capacitor
C3, C4	2	1000 μ F, 6.3V electrolytic capacitors* Sanyo 6CV1000AX
C5	0	Not installed
L1	1	10 μ H inductor Sumida CLS62B-100 or Coiltronics TP2-100
R1	1	60.4k Ω 1% resistor
R2, R3	2	20.0k Ω 1% resistors
R4	1	1M Ω 5% resistor
R5	0	Not installed (for MAX1687 only)
U1	1	MAX1688EUE
None	1	MAX1688 PC board
None	1	MAX1688 data sheet

*For low-profile applications, use Sprague tantalum 595108X06R3R2.

Component Suppliers

SUPPLIER	PHONE	FAX
AVX	803-946-0690	803-626-3123
Coiltronics	561-241-7876	561-241-9339
Dale-Vishay	402-564-3131	402-563-6418
Sanyo	619-661-6835	619-661-1055
Sprague	603-224-1961	603-224-1430
Sumida	708-956-0666	708-956-0702

Features

- ◆ 2.7V to 6V Input Voltage Range
- ◆ 5V Output Voltage
- ◆ Less than 500mV Output Voltage Droop with 1.42A Burst Current
- ◆ 90% Efficiency
- ◆ Output Disconnected from Input during Shutdown
- ◆ 600kHz Switching Frequency
- ◆ Internal MOSFET and Synchronous Rectifier
- ◆ 3 μ A IC Shutdown Current
- ◆ Surface-Mount Components (TSSOP Package)
- ◆ Fully Assembled and Tested

Ordering Information

PART	TEMP. RANGE	IC PACKAGE
MAX1688EVKIT	0°C to +70°C	16 TSSOP

Note: To evaluate the MAX1687, order a MAX1687EUE sample with the MAX1688 EV kit.

Quick Start

The MAX1688 EV kit is fully assembled and tested. Follow these steps to verify board operation. **Do not turn on the power supply until all connections are completed.**

- 1) Connect a 3V supply voltage to the VIN pad. Connect the supply ground to the GND pad.
- 2) Connect a voltmeter and load, if any, to the VOUT pad.
- 3) Turn on the power supply.
- 4) Synchronize the GSM pulse load to the ON signal by applying the logic signal that controls the power amplifier to the ON/ OFF pad. ON is low when GSM load is applied.
- 5) Verify the output voltage is 5V. For other output voltages, refer to the *Adjusting the Output Voltage* section in the MAX1687/MAX1688 data sheet for instructions on selecting the feedback resistors.

Evaluates: MAX1687/MAX1688



MAX1688 Evaluation Kit

Detailed Description

The MAX1688 EV kit is designed for supplying short-duration, high-current bursts for GSM cell phone applications. It combines a boost switching regulator, an N-channel power MOSFET, a P-channel synchronous rectifier, and a precision reference in a single, tiny 16-pin TSSOP package. The EV kit accepts a positive input between 2.7V and 6V and converts it to a 5V output with less than 500mV output voltage droop at 1.4A burst load. The EV kit operates at 600kHz, allowing the use of small external components. For other applications including component value selection, refer to the *Applications Information* section in the MAX1687/MAX1688 data sheet.

Evaluating the MAX1687

The MAX1688 EV kit can also be used to evaluate the MAX1687. Follow the steps below to evaluate the MAX1687.

- 1) Replace the MAX1688 with a MAX1687EUE.
- 2) Install a short at location JU1 to run the MAX1687 continuously or apply a logic signal for ON/OFF control.
- 3) Turn on the power supply.
- 4) Set up the voltage to the MAX1687's LIM pad by applying an external voltage to the CHG(LIM) pad or by completing the voltage divider (R3/R5). Refer to the *Adjusting Current Limit (MAX1687)* section of the MAX1687/MAX1688 data sheet.

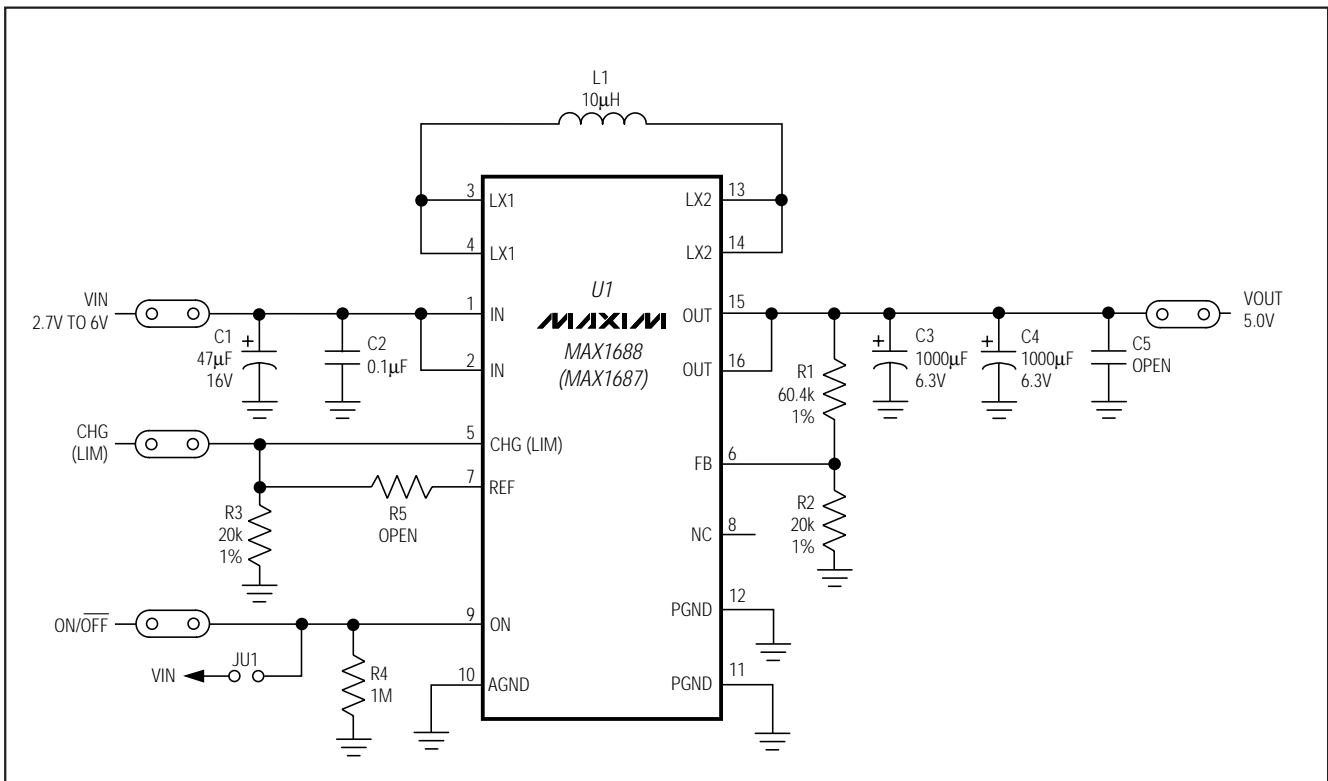

Figure 1. MAX1688 EV Kit Schematic

MAX1688 Evaluation Kit

Evaluates: MAX1687/MAX1688

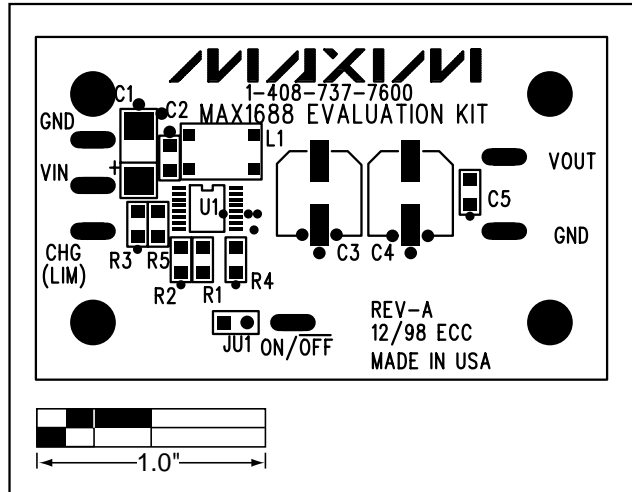

Figure 2. MAX1688 EV Kit Component Placement Guide—Component Side

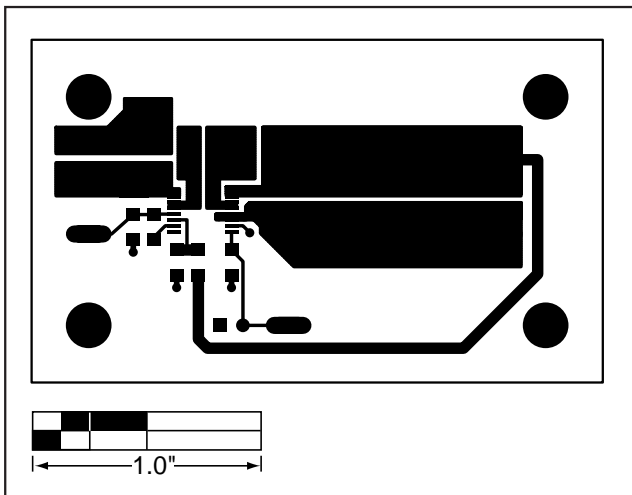

Figure 3. MAX1688 EV Kit PC Board Layout—Component Side

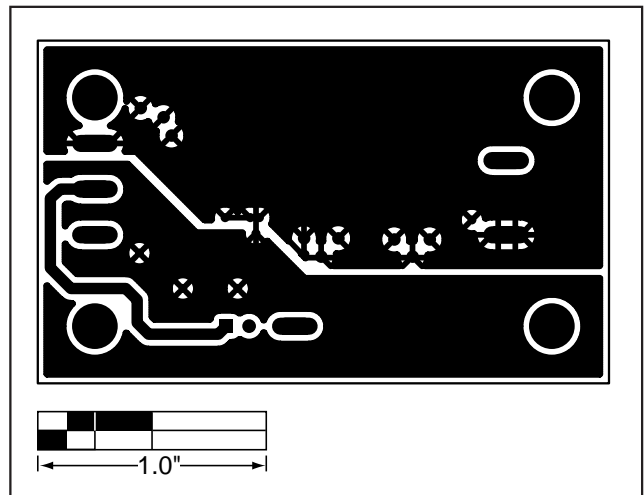

Figure 4. MAX1688 EV Kit PC Board Layout—Solder Side

MAX1688 Evaluation Kit

Evaluates: MAX1687/MAX1688

NOTES

Maxim cannot assume responsibility for use of any circuitry other than circuitry entirely embodied in a Maxim product. No circuitry patent licenses are implied. Maxim reserves the right to change the circuitry and specifications without notice at any time.

4 _____ **Maxim Integrated Products, 120 San Gabriel Drive, Sunnyvale, CA 94086 408-737-7600**

X-ON Electronics

Largest Supplier of Electrical and Electronic Components

Click to view similar products for [Power Management IC Development Tools](#) category:

Click to view products by [Maxim](#) manufacturer:

Other Similar products are found below :

[EVB-EP5348UI](#) [MIC23451-AAAYFL EV](#) [MIC5281YMME EV](#) [124352-HMC860LP3E](#) [DA9063-EVAL](#) [ADP122-3.3-EVALZ](#) [ADP130-0.8-EVALZ](#) [ADP130-1.8-EVALZ](#) [ADP1740-1.5-EVALZ](#) [ADP1870-0.3-EVALZ](#) [ADP1874-0.3-EVALZ](#) [ADP199CB-EVALZ](#) [ADP2102-1.25-EVALZ](#) [ADP2102-1.875EVALZ](#) [ADP2102-1.8-EVALZ](#) [ADP2102-2-EVALZ](#) [ADP2102-3-EVALZ](#) [ADP2102-4-EVALZ](#) [AS3606-DB](#) [BQ25010EVM](#) [BQ3055EVM](#) [ISLUSBI2CKIT1Z](#) [LP38512TS-1.8EV](#) [EVAL-ADM1186-1MBZ](#) [EVAL-ADM1186-2MBZ](#) [ADP122UJZ-REDYKIT](#) [ADP166Z-REDYKIT](#) [ADP170-1.8-EVALZ](#) [ADP171-EVALZ](#) [ADP1853-EVALZ](#) [ADP1873-0.3-EVALZ](#) [ADP198CP-EVALZ](#) [ADP2102-1.0-EVALZ](#) [ADP2102-1-EVALZ](#) [ADP2107-1.8-EVALZ](#) [ADP5020CP-EVALZ](#) [CC-ACC-DBMX-51](#) [ATPL230A-EK](#) [MIC23250-S4YMT EV](#) [MIC26603YJL EV](#) [MIC33050-SYHL EV](#) [TPS60100EVM-131](#) [TPS65010EVM-230](#) [TPS71933-28EVM-213](#) [TPS72728YFFEVM-407](#) [TPS79318YEQEVM](#) [UCC28810EVM-002](#) [XILINXPWR-083](#) [LMR22007YMINI-EVM](#) [LP38501ATJ-EV](#)