

MAX16929 Evaluation Kit

Evaluates: MAX16929

General Description

The MAX16929 evaluation kit (EV kit) is a fully assembled and tested surface-mount PCB that provides the voltages and features required for automotive thin-film transistor (TFT), liquid-crystal display (LCD) applications. The EV kit includes one step-down and one step-up switching regulator, one positive gate and one negative gate voltage regulator, one 3.3V regulator controller with external npn transistor, and one positive and one negative charge pump.

The EV kit can operate from 4.5V to 28V input voltages and is optimized for automotive TFT-LCD applications. The step-down switching regulator is configured for a 5V output that provides at least 1.2A. The step-up switching regulator is configured for a 12V output that provides at least 500mA. The positive gate voltage regulator provides 18V output and the negative gate voltage regulator provides -6.2V.

Features

- ◆ 4.5V to 28V Input Range
- ◆ Output Voltages
 - 5V Output at 1.2A (Step-Down Switching Regulator)
 - 12V Output at 500mA (Step-Up Switching Regulator)
 - 3.3V Output at 500mA (Regulator Controller)
 - 18V Output (Positive Gate Voltage Regulator)
 - 6.2V Output (Negative Gate Voltage Regulator)
- ◆ High-Frequency Operation
 - 2.1MHz (Buck Converter)
 - 2.2MHz (Boost Converter)
- ◆ Adjustable Positive and Negative Charge Pumps
- ◆ Proven PCB Layout
- ◆ Fully Assembled and Tested

Ordering Information appears at end of data sheet.

Component List

DESIGNATION	QTY	DESCRIPTION
AVL, FBB	2	Test points
C1, C4, C22, C24	4	10 μ F \pm 20%, 35V X7R ceramic capacitors (1210) Murata GRM32ER7YA106K Taiyo Yuden GMK325F106ZH
C2, C3, C5, C14, C17, C25, C27, C39	8	0.1 μ F \pm 10%, 50V X7R ceramic capacitors (0603) Murata GRM188R71H104K TDK C1608X7R1H104K
C6	1	2.2 μ F \pm 20%, 6.3V X5R ceramic capacitor (0603) Murata GRM188R60J225K TDK C1608X5R0J225K
C7	1	220pF \pm 10%, 50V X7R ceramic capacitor (0603) Murata GRM188R71H221K
C8, C40, C41	0	Not installed, ceramic capacitors (0603)
C9	1	150pF \pm 5%, 50V C0G ceramic capacitor (0603) Murata GRM1885C1H151J

DESIGNATION	QTY	DESCRIPTION
C12, C13, C16, C21	4	1 μ F \pm 10%, 50V X7R ceramic capacitors (0805) Murata GRM21BR71H105K TDK C2012X7R1H105K
C15	1	47 μ F \pm 20%, 50V aluminum electrolytic capacitor (D case) Panasonic EEE-1HA470XP
C18, C19	2	10 μ F \pm 10%, 25V X7R ceramic capacitors (1210) Murata GRM32DR71E106K
C20	1	1 μ F \pm 10%, 16V X7R ceramic capacitor (0603) Murata GRM188R71C105K
C23, C29, C37, C38, C42, C43	0	Not installed, ceramic capacitors (1210)
C26	1	4.7 μ F \pm 20%, 25V X7R ceramic capacitor (1206) Murata GRM31CR71E475M TDK C3216X7R1E475M
C28, C30	0	Not installed, ceramic capacitors (0805)

MAX16929 Evaluation Kit

Evaluates: MAX16929

Component List (continued)

DESIGNATION	QTY	DESCRIPTION
D1, D6	2	200mA, 100V dual series diodes (SOT23) Fairchild MMBD4148SE Central Semi CMPD7000+
D2, D3	2	3A, 30V Schottky diodes (M-Flat) Toshiba CMS02(TE12L,Q)
D4	1	2A, 50V fast-recovery diode (SMB) Fairchild ES2A
D5	1	2A, 60V Schottky diode (SMB) Diodes Inc. B260-13-F
D7	1	Clear, red SMD LED (0805)
D8, D9	0	Not installed, diodes (SOT23)
FB1	0	Not installed, ferrite-bead inductor—short (PC trace) (0603)
JU1, JU3, JU4	3	2-pin headers, 0.1in centers
JU2, JU6, JU7	3	3-pin headers, 0.1in centers
JU5	0	Not installed, 2-pin header—short (PC trace)
JU8	1	4-pin header, 0.1in centers
L1	1	3.3 μ H, 9A power inductor Würth 744314330
L2	1	4.7 μ H, 6A inductor Würth 744311470
P1	1	-20V, 2.4A, p-channel MOSFET (3 SuperSOT) Fairchild FDN304P

DESIGNATION	QTY	DESCRIPTION
Q1	1	npn bipolar transistor (SOT23) Fairchild MMBT3904
Q2	1	npn high-gain transistor (SOT89) Zetex ZXTN25012EZ
R1, R2, R20	0	Not installed, resistors (0603)
R3	1	33 Ω \pm 5% resistor (0603)
R5	1	180k Ω \pm 5% resistor (0603)
R6	1	169k Ω \pm 1% resistor (0603)
R7	1	10k Ω \pm 1% resistor (0603)
R9	1	300 Ω \pm 5% resistor (0603)
R10	1	100k Ω \pm 5% resistors (0603)
R11	1	133k Ω \pm 1% resistor (0603)
R12	1	12.1k Ω \pm 1% resistor (0603)
R13, R23	2	6.8k Ω \pm 5% resistors (0603)
R14	1	316k Ω \pm 1% resistor (0603)
R15	1	51.1 Ω \pm 1% resistor (0603)
R16	1	10k Ω \pm 5% resistor (0603)
R17	1	4.7k Ω \pm 5% resistor (0603)
R21	1	33k Ω \pm 5% resistor (0603)
R22	1	30k Ω \pm 1% resistor (0603)
TP1, TP2	0	Not installed, test points
U1	1	Automotive TFT-LCD power supply (28 TSSOP) Maxim MAX16929EGUI/V+
—	7	Shunts
—	1	PCB: MAX16929 EVALUATION KIT

Component Suppliers

SUPPLIER	PHONE	WEBSITE
Central Semiconductor Corp.	631-435-1110	www.centalsemi.com
Diodes Incorporated	805-446-4800	www.diodes.com
Fairchild Semiconductor	888-522-5372	www.fairchildsemi.com
Murata Electronics North America, Inc.	770-436-1300	www.murata-northamerica.com
Panasonic Corp.	800-344-2112	www.panasonic.com
Taiyo Yuden	800-348-2496	www.t-yuden.com
TDK Corp.	847-803-6100	www.component.tdk.com
Toshiba America Electronic Components, Inc.	949-623-2900	www.toshiba.com/taec
Würth Elektronik GmbH & Co. KG	201-785-8800	www.we-online.com
Zetex Semiconductors (Division of Diodes Incorporated)	805-446-4800	www.diodes.com

Note: Indicate that you are using the MAX16929 when contacting these component suppliers.

MAX16929 Evaluation Kit

Evaluates: MAX16929

Quick Start

Recommended Equipment

- MAX16929 EV kit
- 4.5V to 28V, 2A DC power supply
- Voltmeter

Procedure

The EV kit is fully assembled and tested. Follow the steps below to verify board operation. **Caution: Do not turn on the power supply until all connections are completed.**

- 1) Verify that shunts are installed on jumpers JU1, JU3, and JU4.
- 2) Verify that a shunt is installed on pins 2-3 of jumper JU2.
- 3) Verify that a shunt is installed on pins 1-2 of jumpers JU6 and JU7.
- 4) Verify that a shunt is installed on pins 1-3 of jumper JU8.
- 5) Connect the positive terminal of the power supply to the IN1 PCB pad. Connect the negative terminal of the power supply to the PGND PCB pads closest to IN1.
- 6) Set the power-supply VIN to 12V.
- 7) Turn on the power supply and verify that the step-down switching regulator output (VBUCK) is 5V.
- 8) Verify that the step-up switching regulator (VSH) is 12V.
- 9) Verify that the 3.3V regulator is 3.3V.
- 10) Verify that the positive gate voltage regulator (VGH) is approximately 18V.
- 11) Verify that the negative gate voltage regulator (VGL) is approximately -6.2V.

Table 1. Jumper JU1 Functions (ENP)

SHUNT POSITION	ENP PIN	VSH, VCN, VCP, AND 3.3V OUTPUTS
Installed*	Connected to INA through resistor R16	Enabled
Not installed	Internally pulled to GND	Disabled

*Default position.

Table 2. Jumper JU2 Functions (SEQ)

SHUNT POSITION	SEQ PIN	SUPPLY SEQUENCING ORDER
1-2	Connected to INA	VGL, VGH
2-3*	Connected to GND	VGH, VGL

*Default position.

Detailed Description of Hardware

Jumper Settings

Several jumper settings in the following tables illustrate some of the features of the EV kit.

Boost Circuitry and 3.3V Regulator Controller Enable Input (JU1)

The device's ENP pin enables the boost circuitry, charge pumps, and 3.3V regulator controller. When a shunt is installed on jumper JU1, the boost converter, charge pumps, and 3.3V regulator are enabled. When JU1 is left open, the corresponding outputs are disabled. See Table 1 for JU1 configuration.

Supply Sequencing (JU2)

The device's SEQ pin controls the order in which the VGH and VGL supplies are sequenced. When a shunt is installed on pins 1-2 of jumper JU2, VGL is turned on first followed by VGH. When a shunt is installed on pins 2-3, VGH is turned on first followed by VGL. See Table 2 for JU2 configuration.

INA Input Supply (JU3)

The boost converter and 3.3V regulator controller's input (INA) can be supplied from the output of the step-down regulator or from an external 5V power supply. Jumper JU3 controls the INA supply options. See Table 3 for JU3 configuration.

Buck Converter Enable Input (JU4)

The device's ENB pin enables the step-down switching regulator circuitry. When a shunt is installed on jumper JU4, the buck converter is enabled. When JU4 is left open, the buck converter is disabled. See Table 4 for JU4 configuration.

Table 3. Jumper JU3 Functions (INA)

SHUNT POSITION	INA PIN
Installed*	Powered from the VBUCK output
Not installed	Powered from the external 5V supply

*Default position.

Table 4. Jumper JU4 Functions (ENB)

SHUNT POSITION	ENB PIN	VBUCK OUTPUTS
Installed*	Connected to INB through resistor R21	Enabled
Not installed	Internally pulled to GND	Disabled

*Default position.

MAX16929 Evaluation Kit

Evaluates: MAX16929

Charge-Pump Configuration (JU6, JU7)

The EV kit provides a single-stage positive and negative charge pump. For additional flexibility, the option to add an additional stage to these charge pumps is also provided. To use the default single-stage charge pumps, set jumpers JU6 and JU7 to pins 1-2. To utilize the additional circuitry, JU6 and JU7 must be set to pins 2-3. Additional components must be populated when using this option; C40, C42, and D9 for the negative charge pump and C41, C43, and D8 for the positive charge pump. Refer to the *Charge Pumps* section in the MAX16929 IC data sheet for more detailed information and component selection. When using multiple charge-pump stages, it is important not to exceed the maximum rating of the CP pin.

Positive Charge-Pump Adjustable Output (JU8)

The EV kit's positive charge-pump output voltage can be adjusted through jumper JU8. JU8 sets the voltage at D1's anode (the voltage to which flying capacitor C3 is charged), in turn setting the output. Refer to the *Charge Pumps* section in the MAX16929 IC data sheet for more detailed information. See Table 5 for JU8 configuration.

Output-Voltage Selection

Boost Converter

The EV kit's step-up switching-regulator output (VSH) is set to 12V by feedback resistors R11 and R12. To generate output voltages other than 12V, select different external voltage-divider resistors, R11 and R12. Refer to

the *Boost Converter, Output-Voltage Selection* section in the MAX16929 IC data sheet for more information. When using higher boost output voltages, it is important not to exceed the maximum rating of the CP pin.

Positive Gate Voltage Regulator

The EV kit's positive gate voltage regulator output (VGH) is set to 18V by feedback resistors R6 and R7. To generate output voltages other than 18V, select different external voltage-divider resistors, R6 and R7. Refer to the *Positive Gate Voltage Regulator, Output-Voltage Selection* section in the MAX16929 IC data sheet for more information.

Negative Gate Voltage Regulator

The EV kit's negative gate voltage regulator output (VGL) is set to -6.2V by feedback resistors R14 and R15. To generate output voltages other than -6.2V, select different external voltage-divider resistors, R14 and R15. Refer to the *Negative Gate Voltage Regulator, Output-Voltage Selection* section in the MAX16929 IC data sheet for more information.

Table 5. Jumper JU8 Functions (D1)

SHUNT POSITION	D1 ANODE VOLTAGE
1-2	3.3V
1-3*	VSH
1-4	VBUCK

*Default position.

MAX16929 Evaluation Kit

Evaluates: MAX16929

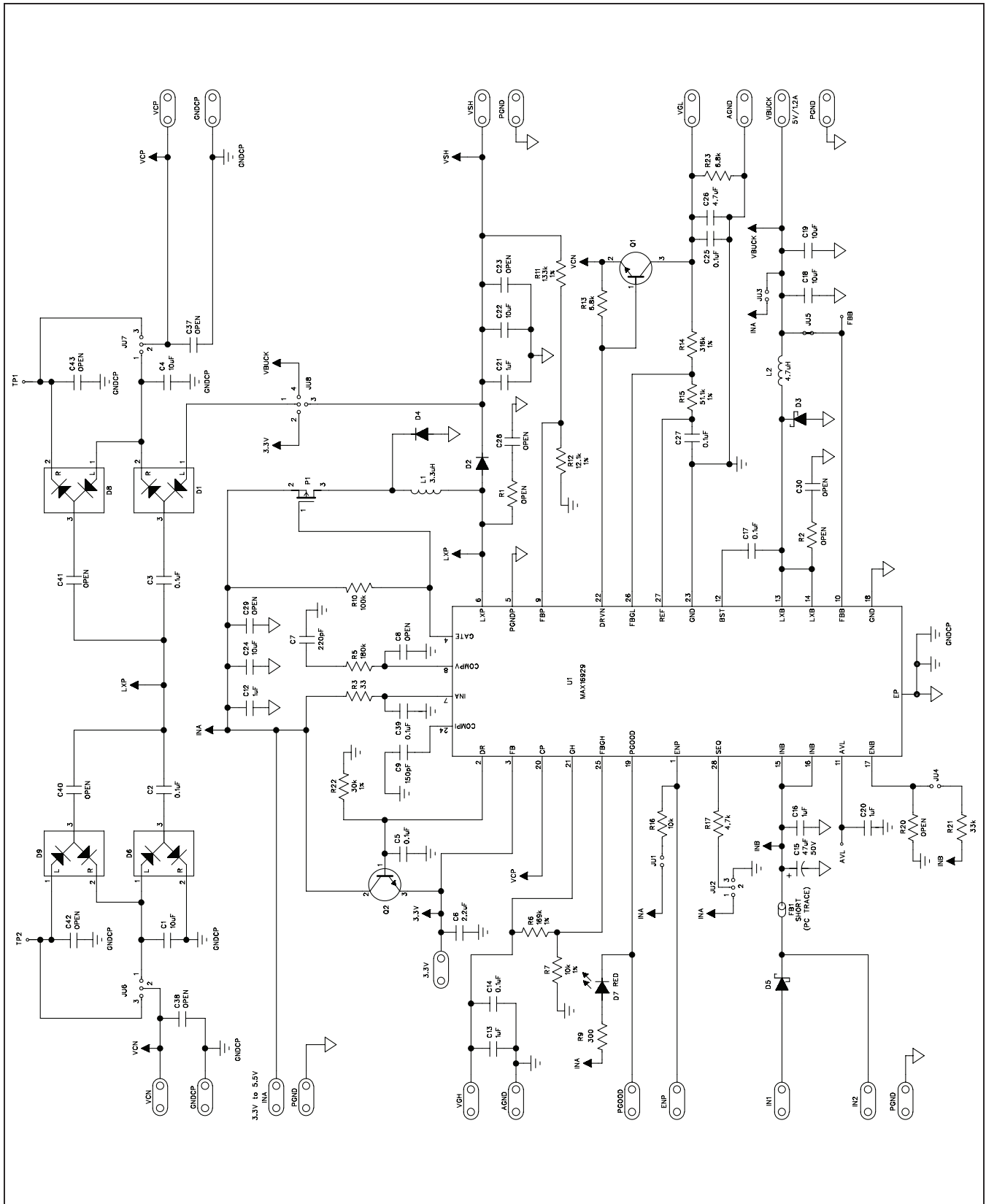

Figure 1. MAX16929 EV Kit Schematic

MAX16929 Evaluation Kit

Evaluates: MAX16929

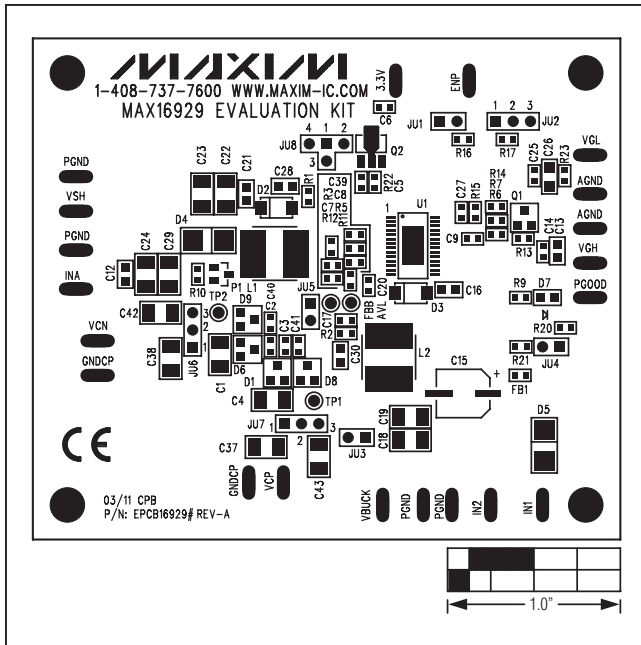

Figure 2. MAX16929 EV Kit Component Placement Guide—Component Side

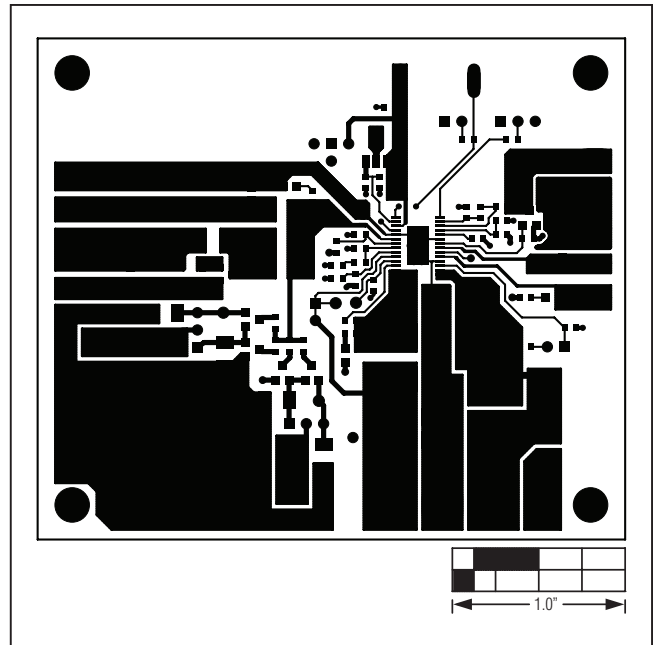

Figure 3. MAX16929 EV Kit PCB Layout—Component Side

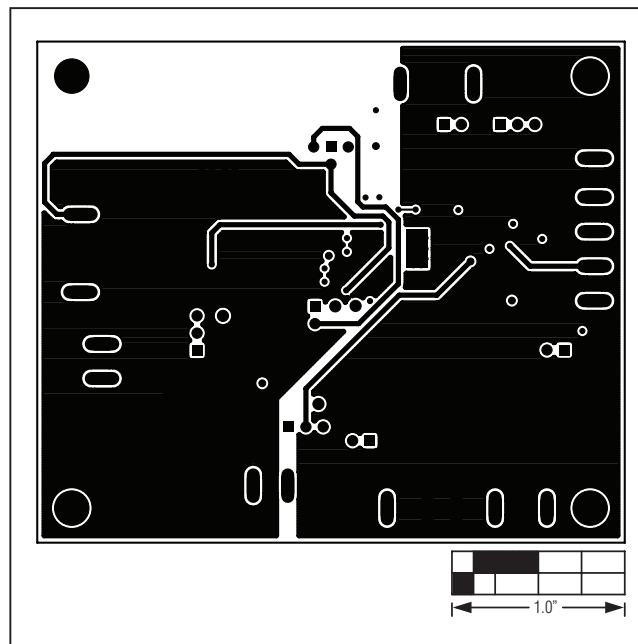

Figure 4. MAX16929 EV Kit PCB Layout—Layer 2

MAX16929 Evaluation Kit

Evaluates: MAX16929

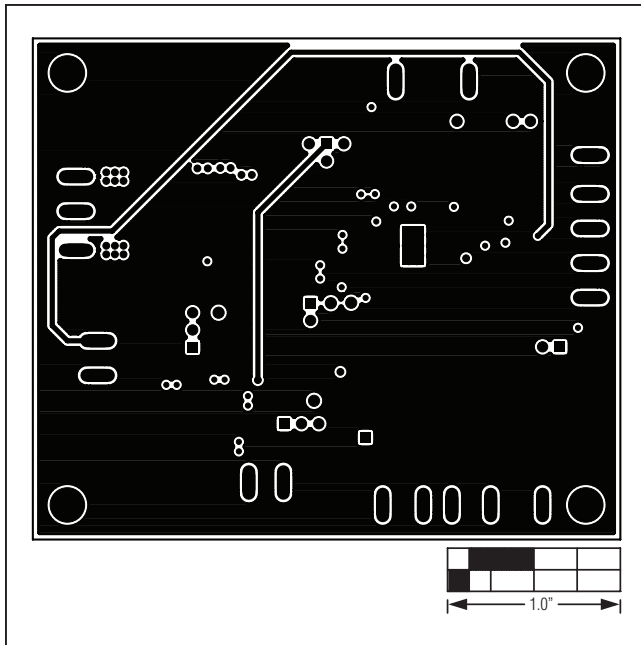

Figure 5. MAX16929 EV Kit PCB Layout—Layer 3

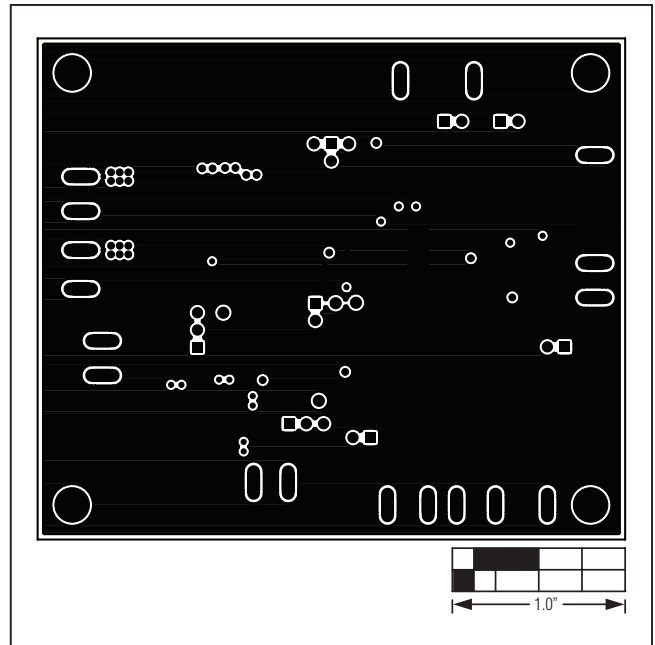

Figure 6. MAX16929 EV Kit PCB Layout—Solder Side

MAX16929 Evaluation Kit

Evaluates: MAX16929

Ordering Information

PART	TYPE
MAX16929EVKIT#	EV Kit

#Denotes RoHS compliant.

MAX16929 Evaluation Kit

Evaluates: MAX16929

Revision History

REVISION NUMBER	REVISION DATE	DESCRIPTION	PAGES CHANGED
0	4/11	Initial release	—

Maxim cannot assume responsibility for use of any circuitry other than circuitry entirely embodied in a Maxim product. No circuit patent licenses are implied. Maxim reserves the right to change the circuitry and specifications without notice at any time.

Maxim Integrated Products, 120 San Gabriel Drive, Sunnyvale, CA 94086 408-737-7600 _____ 9

X-ON Electronics

Largest Supplier of Electrical and Electronic Components

Click to view similar products for [Power Management IC Development Tools](#) category:

Click to view products by [Maxim](#) manufacturer:

Other Similar products are found below :

[EVB-EP5348UI](#) [MIC23451-AAAYFL EV](#) [MIC5281YMME EV](#) [124352-HMC860LP3E](#) [DA9063-EVAL](#) [ADP122-3.3-EVALZ](#) [ADP130-0.8-EVALZ](#) [ADP130-1.8-EVALZ](#) [ADP1740-1.5-EVALZ](#) [ADP1870-0.3-EVALZ](#) [ADP1874-0.3-EVALZ](#) [ADP199CB-EVALZ](#) [ADP2102-1.25-EVALZ](#) [ADP2102-1.875EVALZ](#) [ADP2102-1.8-EVALZ](#) [ADP2102-2-EVALZ](#) [ADP2102-3-EVALZ](#) [ADP2102-4-EVALZ](#) [AS3606-DB](#) [BQ25010EVM](#) [BQ3055EVM](#) [ISLUSBI2CKIT1Z](#) [LP38512TS-1.8EV](#) [EVAL-ADM1186-1MBZ](#) [EVAL-ADM1186-2MBZ](#) [ADP122UJZ-REDYKIT](#) [ADP166Z-REDYKIT](#) [ADP170-1.8-EVALZ](#) [ADP171-EVALZ](#) [ADP1853-EVALZ](#) [ADP1873-0.3-EVALZ](#) [ADP198CP-EVALZ](#) [ADP2102-1.0-EVALZ](#) [ADP2102-1-EVALZ](#) [ADP2107-1.8-EVALZ](#) [ADP5020CP-EVALZ](#) [CC-ACC-DBMX-51](#) [ATPL230A-EK](#) [MIC23250-S4YMT EV](#) [MIC26603YJL EV](#) [MIC33050-SYHL EV](#) [TPS60100EVM-131](#) [TPS65010EVM-230](#) [TPS71933-28EVM-213](#) [TPS72728YFFEVM-407](#) [TPS79318YEQEVM](#) [UCC28810EVM-002](#) [XILINXPWR-083](#) [LMR22007YMINI-EVM](#) [LP38501ATJ-EV](#)