



MAX16974 Evaluation Kit

General Description

The MAX16974 evaluation kit (EV kit) provides a proven design to evaluate the MAX16974 high-voltage, 2.2MHz, 2A automotive step-down controller with low operating current. It is designed to operate with 3.5V to 28V input voltages, while using only 35 μ A quiescent current at no load. The switching frequency is adjustable from 220kHz to 2.2MHz and the output voltage is pin selectable at 5V fixed or 1V to 10V adjustable. This EV kit is initially set up to operate at 2.2MHz with a 5V output.

The EV kit PCB comes with a MAX16974AUE/V+ installed.

Features

- ◆ Wide 3.5V to 28V DC Supply Range
- ◆ 42V Input Transient Tolerance
- ◆ Proven PCB Layout
- ◆ Fully Assembled and Tested

Ordering Information

PART	TYPE
MAX16974EVKIT+	EV Kit

+Denotes lead(Pb)-free and RoHS compliant.

Component List

DESIGNATION	QTY	DESCRIPTION
CBST	1	0.1 μ F \pm 10%, 6.3V X5R ceramic capacitor (0402) TDK C1005X5R0J104K
CCOMP1	1	5600pF \pm 10%, 50V X7R ceramic capacitor (0603) Murata GRM188R71H562K
CCOMP2	0	Not installed, 120pF \pm 5%, 50V C0G ceramic capacitor (0603) Murata GRM1885C1H121J
CCRES	1	100pF \pm 5%, 50V C0G ceramic capacitor (0603) Murata GRM1885C1H101J
CFB1	0	Not installed, ceramic capacitor (0603)
CIN1	1	47 μ F \pm 20%, 50V electrolytic capacitor (D8) Panasonic EEE-FK1H470XP
CIN2, CIN3	2	0.1 μ F \pm 10%, 50V X7R ceramic capacitors (0603) Murata GRM188R71H104K
CIN4, CIN5	2	4.7 μ F \pm 10%, 50V X7R ceramic capacitors (1210) Murata GRM32ER71H475K
COUT, COUT2	2	22 μ F \pm 20%, 10V X7R ceramic capacitors (1210) Murata GRM32ER71A226K
CSNUB	0	Not installed, 1000pF \pm 10%, 50V X7R ceramic capacitor (0603) Murata GRM188R71H102K

DESIGNATION	QTY	DESCRIPTION
CVL	1	2.2 μ F \pm 10%, 10V X7R ceramic capacitor (0603) Murata GRM188R71A225K
D1	1	3A, 60V Schottky diode Diodes Inc. B360B
JU1	1	3-pin header
JU2, JU7	0	Not installed, 0 Ω jumpers (0603)
JU3, JU6, RTEST	3	0 Ω \pm 5% resistors (0603)
L1	1	4.7 μ H \pm 20%, 2.8A, 20m Ω inductor (7.0mm x 7.5mm) Panasonic ETQP5M4R7YFM
LX	0	Not installed, multipurpose test point
RCOMP	1	20k Ω \pm 1% resistor (0603)
RFB1, RFB2, RFB3	0	Not installed, resistors (0603)
RFOSC	1	12.1k Ω \pm 1% resistor (0603)
RFSYNC	1	20k Ω \pm 5% resistor (0603)
RRESB	1	10k Ω \pm 5% resistor (0603)
RSNUB	0	Not installed, 3 Ω \pm 5% resistor (0603)
U1	1	High-voltage automotive step-down converter (16 TSSOP-EP*) Maxim MAX16974AUE/V+
—	1	Shunts
—	1	PCB: MAX16974 EVALUATION KIT+

*EP = Exposed pad.

/V denotes an automotive qualified part.

Evaluates: MAX16974

MAX16974 Evaluation Kit

Component Suppliers

SUPPLIER	PHONE	WEBSITE
Diodes Incorporated	805-446-4800	www.diodes.com
Murata Electronics North America, Inc.	770-436-1300	www.murata-northamerica.com
Panasonic Corp.	800-344-2112	www.panasonic.com
TDK Corp.	847-803-6100	www.component.tdk.com

Note: Indicate that you are using the MAX16974 when contacting these component suppliers.

Quick Start

Recommended Equipment

- MAX16974 EV kit
- 12V at 2A DC power supply
- Digital voltmeter (DVM)
- 2A DC load (2.5Ω, 10W)

Procedure

The EV kit is fully assembled and tested. Follow the steps below to verify board operation:

- 1) Verify that all jumpers (JU1, JU2, JU3, JU6, and JU7) are in their default positions, as shown in Table 1.
- 2) Connect the DVM between the VOUT and GND pads.
- 3) Connect the load between the VOUT and GND pads.
- 4) Connect the power supply between the EXT_VBAT and GND pads.
- 5) Enable the 12V power supply.
- 6) Verify that VOUT = 5V.
- 7) Verify that RESB is high.

Detailed Description of Hardware

The MAX16974 EV kit provides a proven layout for the MAX16974 IC. The EV kit is designed to fully demonstrate the functionality of the IC as follows:

- Verify output-voltage regulation
- Verify power-good behavior and reset-threshold selection
- Easy programmability of different output voltages between 1V and 10V
- Startup and shutdown performance
- Current-limit performance

The following detailed descriptions enable the user to program the EV kit per application requirements.

External Clock Input (FSYNC)

The IC synchronizes to an external clock signal applied at FSYNC. The signal at FSYNC must have a 10% higher frequency than the internal clock period for proper synchronization.

Output-Voltage/RESET Threshold

Resistive-Divider Network

The output voltage of the IC can be programmed between 1V and 10V. Although the IC's output voltage and reset threshold can be set individually, the EV kit supports the use of a combined resistive-divider network to set the desired output voltage and the reset threshold using three resistors (RFB1, RFB2, and RFB3). Use the following formula to determine the RFB3 of the resistive-divider network:

$$RFB3 = (RFB1 + RFB2 + RFB3) \times V_{REF} / V_{OUT}$$

where $V_{REF} = 1V$ and V_{OUT} is the desired output voltage.

$$RFB2 = ((RFB1 + RFB2 + RFB3) \times V_{REF_RES} / V_{RES}) - RFB3$$

where V_{REF_RES} is 1.2V (refer to the *Electrical Characteristics* section in the MAX16974 IC data sheet) and V_{RES} is the desired reset threshold in volts.

The precision of the reset-threshold function is dependent on the tolerance of the resistors used for the divider. Refer to the MAX16974 IC data sheet for details.

Some applications require the addition of a compensation capacitor at CFB1. Contact the factory for applications assistance.

The 0Ω resistors at JU3 and JU6 must be moved to locations JU2 and JU7 to enable the combined resistive-divider network. As shipped from the factory, the 0Ω resistors are installed at JU3 and JU6, so that FB is tied to VL and RESET1 is tied to ground, selecting the factory settings.

MAX16974 Evaluation Kit

The $\overline{\text{RES}}$ signal is asserted when RESETI is below 1.2V. The RFB1, RFB2, and RFB3 values should be chosen to set RESETI = 1.2V when the OUT voltage is too low. The recommended resistor-divider bias current is 50 μ A.

Reset-Timeout Selection

The CRES pin of the IC is for programming the power-good delay for the IC. The internal threshold of the CRES

comparator is 1.25V. The CRES pin sources approximately 10 μ A current. Placing a capacitor (CCRES) from CRES to GND programs the delay time of the power-good indicator.

Output-Voltage Selection

Contact the factory for assistance in selecting components for other output voltages.

Table 1. Jumper Descriptions (JU1, JU2, JU3, JU6, JU7)

JUMPER	SIGNAL	SHUNT POSITION	DESCRIPTION
JU1	EN	1-2*	EN is tied to VSUP (battery input); normal operation.
		2-3	EN is tied to GND; shutdown.
JU2	FB	0 Ω jumper installed	Output voltage is determined by RFB1, RFB2, and RFB3. OUT regulates FB to 1.00V at the RFB2/RFB3 junction. JU3 must be open.
		Open*	JU3 should be installed. See the JU3 description.
JU3	FB	0 Ω jumper installed*	FB is tied to BIAS; the output voltage is preset to 5V. JU2 must be open.
		Open	JU2 should be installed. See the JU2 description.
JU6	RESETI	0 Ω jumper installed*	RESETI is tied to GND; the reset threshold is preset to 90% of VOUT. JU7 must be open.
		Open	JU7 should be installed. See the JU7 description.
JU7	RESETI	0 Ω jumper installed	Reset threshold is determined by RFB1, RFB2, and RFB3. Reset occurs when RESETI drops down to 1.2V. JU6 must be open.
		Open*	JU6 should be installed. See the JU6 description.

*Default position.

Evaluates: MAX16974

MAX16974 Evaluation Kit

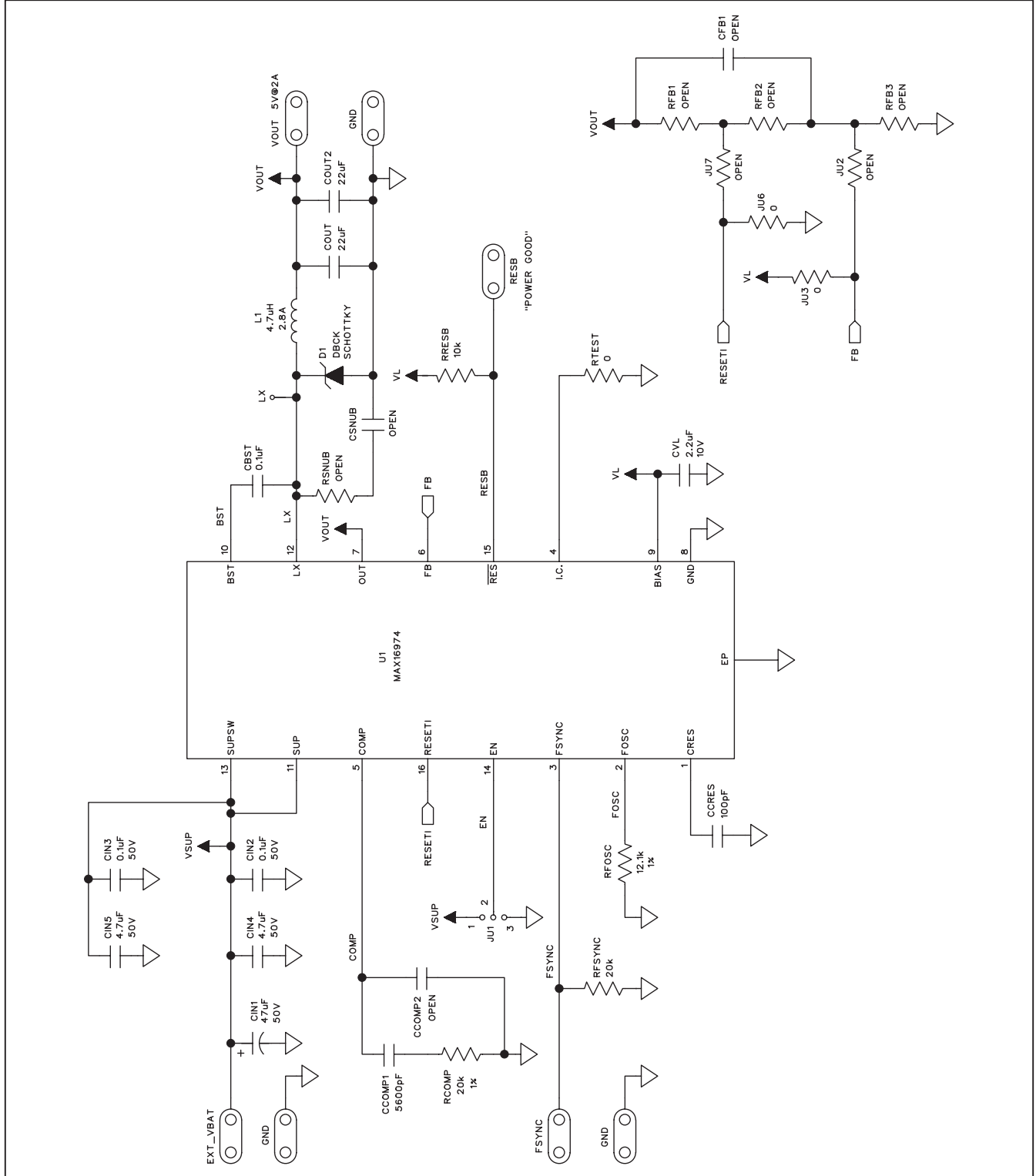

Figure 1. MAX16974 EV Kit Schematic

MAX16974 Evaluation Kit

Evaluates: MAX16974

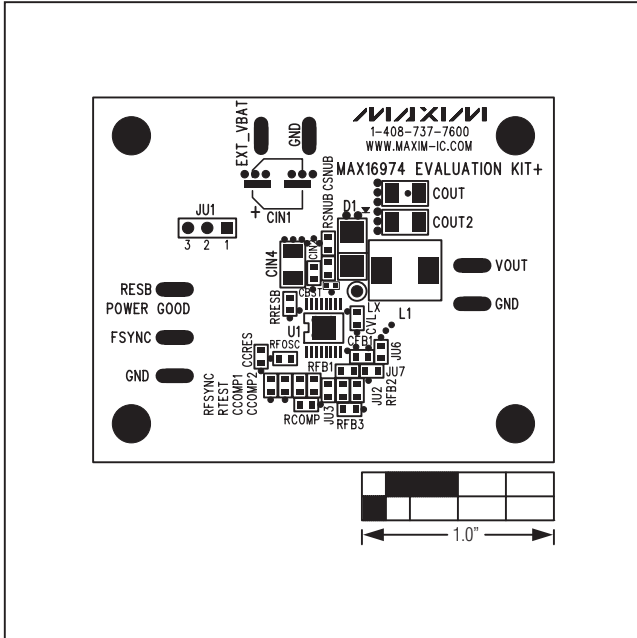

Figure 2. MAX16974 EV Kit Component Placement Guide—Component Side

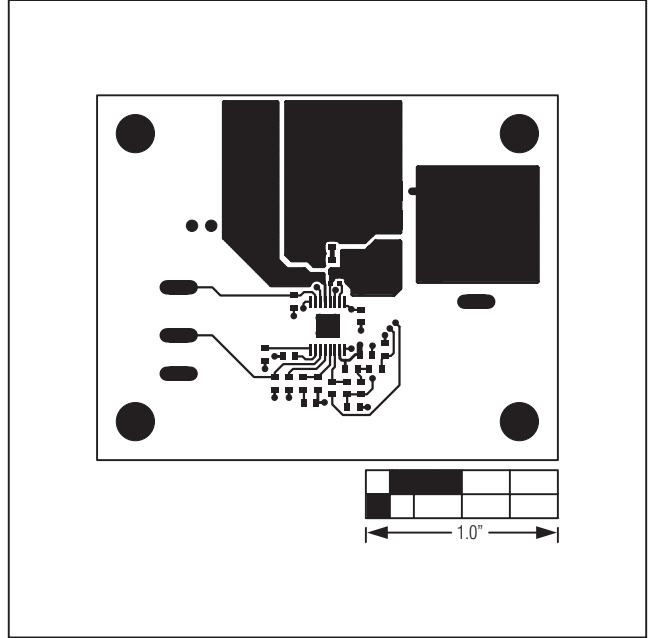

Figure 3. MAX16974 EV Kit PCB Layout—Component Side

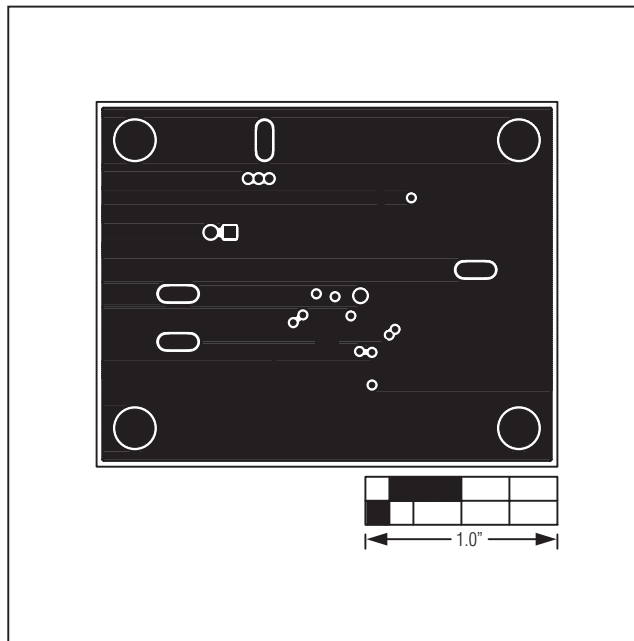

Figure 4. MAX16974 EV Kit PCB Layout—Ground Layer 2

MAX16974 Evaluation Kit

Evaluates: MAX16974

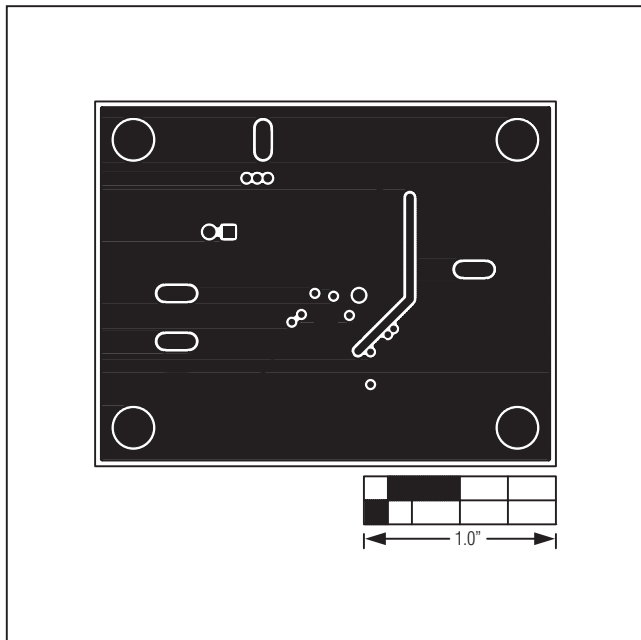

Figure 5. MAX16974 EV Kit PCB Layout—Layer 3

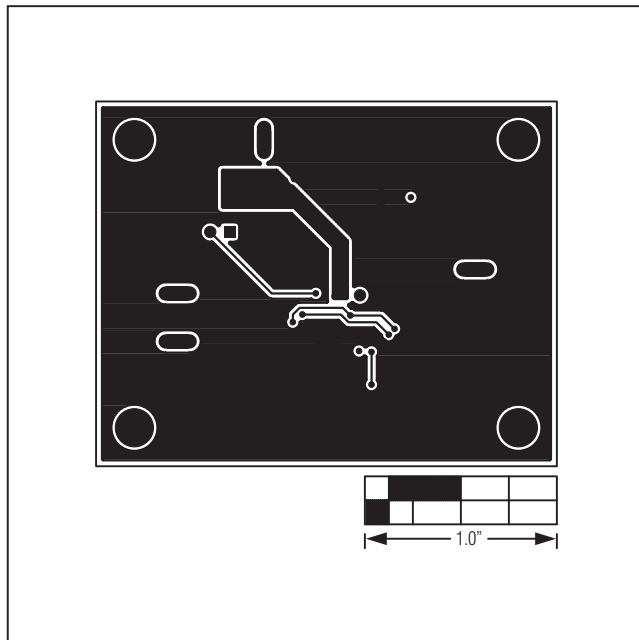

Figure 6. MAX16974 EV Kit PCB Layout—Solder Side

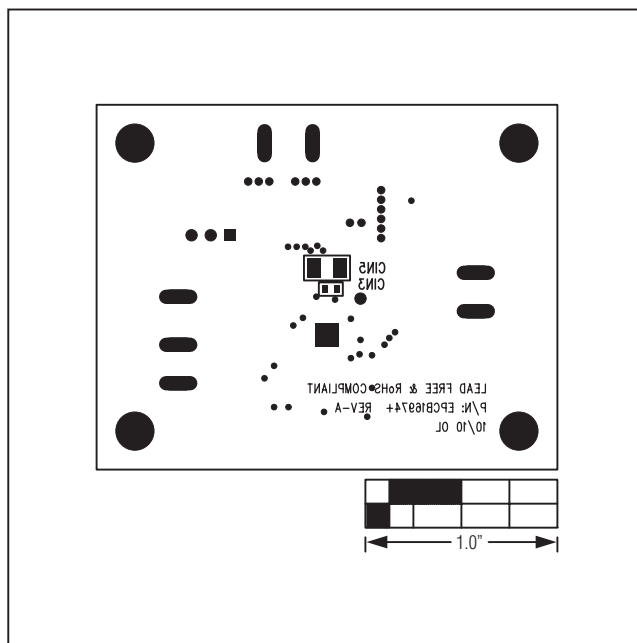

Figure 7. MAX16974 EV Kit Component Placement Guide—Solder Side

MAX16974 Evaluation Kit

Revision History

REVISION NUMBER	REVISION DATE	DESCRIPTION	PAGES CHANGED
0	12/10	Initial release	—

Evaluates: MAX16974

Maxim cannot assume responsibility for use of any circuitry other than circuitry entirely embodied in a Maxim product. No circuit patent licenses are implied. Maxim reserves the right to change the circuitry and specifications without notice at any time.

Maxim Integrated Products, 120 San Gabriel Drive, Sunnyvale, CA 94086 408-737-7600 _____ 7

X-ON Electronics

Largest Supplier of Electrical and Electronic Components

Click to view similar products for [Power Management IC Development Tools](#) category:

Click to view products by [Maxim](#) manufacturer:

Other Similar products are found below :

[EVB-EP5348UI](#) [MIC23451-AAAYFL EV](#) [MIC5281YMME EV](#) [124352-HMC860LP3E](#) [DA9063-EVAL](#) [ADP122-3.3-EVALZ](#) [ADP130-0.8-EVALZ](#) [ADP130-1.8-EVALZ](#) [ADP1740-1.5-EVALZ](#) [ADP1870-0.3-EVALZ](#) [ADP1874-0.3-EVALZ](#) [ADP199CB-EVALZ](#) [ADP2102-1.25-EVALZ](#) [ADP2102-1.875EVALZ](#) [ADP2102-1.8-EVALZ](#) [ADP2102-2-EVALZ](#) [ADP2102-3-EVALZ](#) [ADP2102-4-EVALZ](#) [AS3606-DB](#) [BQ25010EVM](#) [BQ3055EVM](#) [ISLUSBI2CKIT1Z](#) [LP38512TS-1.8EV](#) [EVAL-ADM1186-1MBZ](#) [EVAL-ADM1186-2MBZ](#) [ADP122UJZ-REDYKIT](#) [ADP166Z-REDYKIT](#) [ADP170-1.8-EVALZ](#) [ADP171-EVALZ](#) [ADP1853-EVALZ](#) [ADP1873-0.3-EVALZ](#) [ADP198CP-EVALZ](#) [ADP2102-1.0-EVALZ](#) [ADP2102-1-EVALZ](#) [ADP2107-1.8-EVALZ](#) [ADP5020CP-EVALZ](#) [CC-ACC-DBMX-51](#) [ATPL230A-EK](#) [MIC23250-S4YMT EV](#) [MIC26603YJL EV](#) [MIC33050-SYHL EV](#) [TPS60100EVM-131](#) [TPS65010EVM-230](#) [TPS71933-28EVM-213](#) [TPS72728YFFEVM-407](#) [TPS79318YEQEVM](#) [UCC28810EVM-002](#) [XILINXPWR-083](#) [LMR22007YMINI-EVM](#) [LP38501ATJ-EV](#)