

MAX16984

Automotive High-Current Step-Down Converter with USB Protection/Host Charger Adapter Emulator

General Description

The MAX16984 combines a 5V automotive-grade step-down converter capable of driving up to 2.5A, a USB host charger adapter emulator, and USB protection switches for automotive USB host applications. The USB protection switches provide high-ESD, short-circuit protection and feature integrated host-charger port-detection circuitry adhering to the USB 2.0 Battery Charging Specification BC1.2 battery charging specification and Chinese Telecommunication Industry Standard YD/T 1591-2009. They also include circuitry for iPod®/iPhone® 1.0A and iPad® 2.1A dedicated charging modes. The HVD+ and HVD- ESD protection features include protection to $\pm 15\text{kV}$ Air/ $\pm 8\text{kV}$ Contact on the HVD+ and HVD- outputs to the IEC 61000-4-2 model and 330 Ω , 330pF ESD model.

The high-efficiency step-down DC-DC converter operates from a voltage up to 28V and is protected from load dump transients up to 42V. The device is optimized for high-frequency operation and includes resistor-programmable frequency selection from 220kHz to 2.2MHz to allow optimization of efficiency, noise, and board space based on application requirements. The converter has an internal high-side n-channel switch and uses a low forward-drop freewheeling Schottky diode for rectification. There is a small low-side n-channel switch to maintain fixed frequency under light loads. For lower quiescent current operation requirements, the low side n-channel switch can be disabled to allow skip mode operation under light loads. The converter can deliver up to 2.1A of continuous current at 105°C. The MAX16984S has an integrated spread-spectrum oscillator to improve EMI performance.

The MAX16984 also includes a USB load current-sense amplifier and configurable feedback adjustment circuit designed to provide automatic USB voltage adjustment to compensate for voltage drops in captive cables associated with automotive applications. The MAX16984 limits the USB load current using both a fixed internal peak current threshold of the DC-DC converter and a user-configurable external USB load current-sense amplifier threshold.

Applications

- Automotive Radio and Navigation
- USB Port for Host and Hub Applications
- Automotive Connectivity
- Telematics
- Dedicated USB Power Charger

Benefits and Features

- Integrated DC-DC and USB Host Charge Emulator Enables 1-Chip Solution Directly from Car Battery to Portable Device
 - 4.5V to 28V (42V Load Dump) Operating Voltage
 - 5V, 2.5A Output Current Capability
 - Low-Q Current Skip and Shutdown Modes
 - Soft-Start Reduces Inrush Current
- Low-Noise Features Prevent Interference with AM Band and Portable Devices
 - Fixed-Frequency 220kHz to 2.2MHz Operation
 - Forced-PWM Option at No Load
 - Spread Spectrum for EMI Reduction
 - SYNC Input for Frequency Parking
- Optimal USB Power and Communication for Portable Devices
 - User-Adjustable Voltage Gain Adjusts Output Between 5V and 6.15V for Cable Compensation
 - $\pm 3\%$ Accuracy User-Adjustable USB Current Limit
 - 4 Ω USB 2.0 480Mbps/12Mbps Data Switches
 - Integrated iPod/iPhone/iPad Charge-Detection Termination Resistors
 - Supports USB BC1.2 Charging Downstream Port (CDP) and Dedicated Charging Port (DCP) Modes
 - Supports Chinese Telecommunication Industry Standard YD/T 1591-2009
 - Compatible with USB On-the-Go Specification
 - High-Speed Pass-Through Mode
- Robust Design Keeps Vehicle System and Portable Devices Safe in Automotive Environment
 - Short-to-Battery Protection on DC-DC Converter
 - Short-to-Battery Protection on USB Pins
 - $\pm 25\text{kV}$ Air/ $\pm 8\text{kV}$ Contact ISO 10605
 - $\pm 15\text{kV}$ Air/ $\pm 8\text{kV}$ Contact IEC 61000-4-2
 - $\pm 15\text{kV}$ Air/ $\pm 8\text{kV}$ Contact (330 Ω , 330pF)
 - Fault-Indication Active-Low, Open-Drain Output
 - Reduced Inrush Current with Soft-Start
 - Overtemperature Protection
 - -40°C to $+125^\circ\text{C}$ Operating Temperature Range
 - 28-Pin, 5mm x 5mm, TQFN and Side-Wettable QFND Packages

Ordering Information and **Typical Operating Circuit** appear at end of data sheet.

iPod, iPhone, and iPad are registered trademarks of Apple, Inc.

Pin Configuration

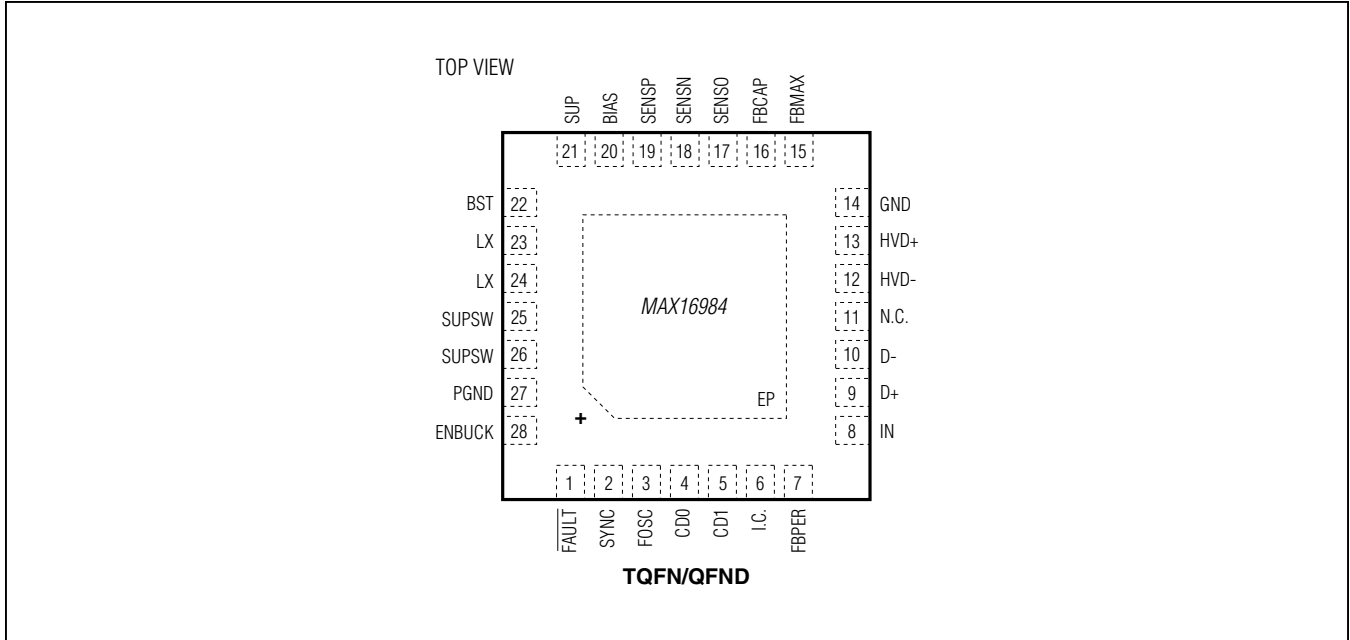

Pin Description

PIN	NAME	FUNCTION
1	FAULT	Active-Low Open-Drain Fault Indicator Output. Connect a 100kΩ pullup resistor to IN.
2	SYNC	Synchronization Input. The device synchronizes to an external signal applied to SYNC. When connected to GND or unconnected, skip mode is allowed under light loads. See Table 1. When connected to a clock source or IN, forced-PWM (FPWM) mode is enabled.
3	FOSC	Resistor-Programmable Switching-Frequency Setting Control Input. Connect a resistor from FOSC to GND to set the switching frequency.
4	CD0	Charger Detection Configuration Bit 0
5	CD1	Charger Detection Configuration Bit 1
6	I.C.	Internal Connection. Must be connected to external GND.
7	FBPER	Digital Input. Used to select voltage feedback adjustment percentage.
8	IN	Logic Enable Input. Connect to I/O voltage of USB transceiver. IN is also used for clamping during overvoltage events on HVD+ or HVD-. Connect a 1μF ceramic capacitor from IN to GND.
9	D+	USB Differential Data D+ Input. Connect D+ to low-voltage USB transceiver D+ pin.
10	D-	USB Differential Data D- Input. Connect D- to low-voltage USB transceiver D- pin.
11	N.C.	No Connection
12	HVD-	High-Voltage-Protected USB Differential Data D- Output. Connect HVD- directly to the USB connector D- pin.

Pin Description (continued)

PIN	NAME	FUNCTION
13	HVD+	High-Voltage-Protected USB Differential Data D+ Output. Connect HVD+ directly to the USB connector D+ pin.
14	GND	Analog Ground
15	FBMAX	Current-Sense Amp Output. Connect a resistor and capacitor to GND to set the voltage-adjustment bandwidth and the USB DC current level at which maximum voltage-feedback adjustment is reached.
16	FBCAP	External Capacitor Connection. Connect a 10pF capacitor to GND.
17	SENSO	Current-Sense Amp Output. Connect a resistor and capacitor to GND to set the maximum USB DC current limit.
18	SENSN	Current-Sense Amp Negative Input. Connect to negative terminal of current-sense resistor.
19	SENSP	DC-DC Converter Feedback Input and Current-Sense Amp Positive Input. Connect to positive terminal of current-sense resistor and the main output of the converter. Used for internal voltage regulation loop.
20	BIAS	5V Linear Regulator Output. Connect a 1 μ F ceramic capacitor from BIAS to GND. BIAS powers up the internal circuitry.
21	SUP	Voltage Supply Input. SUP is the supply pin for the internal linear regulator. Connect a minimum of 4.7 μ F capacitor from SUP to GND close to the IC.
22	BST	High-Side Driver Supply. Connect a 0.1 μ F capacitor from BST to LX.
23, 24	LX	Inductor Connection. Connect a rectifying Schottky diode between LX and GND. Connect an inductor from LX to the DC-DC converter output (SENSP).
25, 26	SUPSW	Internal High-Side Switch-Supply Input. SUPSW provides power to the internal switch. Connect a 4.7 μ F ceramic capacitor in parallel with a 47 μ F capacitor from SUPSW to PGND. See the <i>DC-DC Input Capacitor</i> section.
27	PGND	Power Ground
28	ENBUCK	Battery-Compatible Enable Input. Drive ENBUCK low/high to disable/enable the switching regulator.
—	EP	Exposed Pad. Connect EP to a large-area contiguous copper ground plane for effective power dissipation. Do not use as the only IC ground connection. EP must be connected to GND.

Functional Diagram

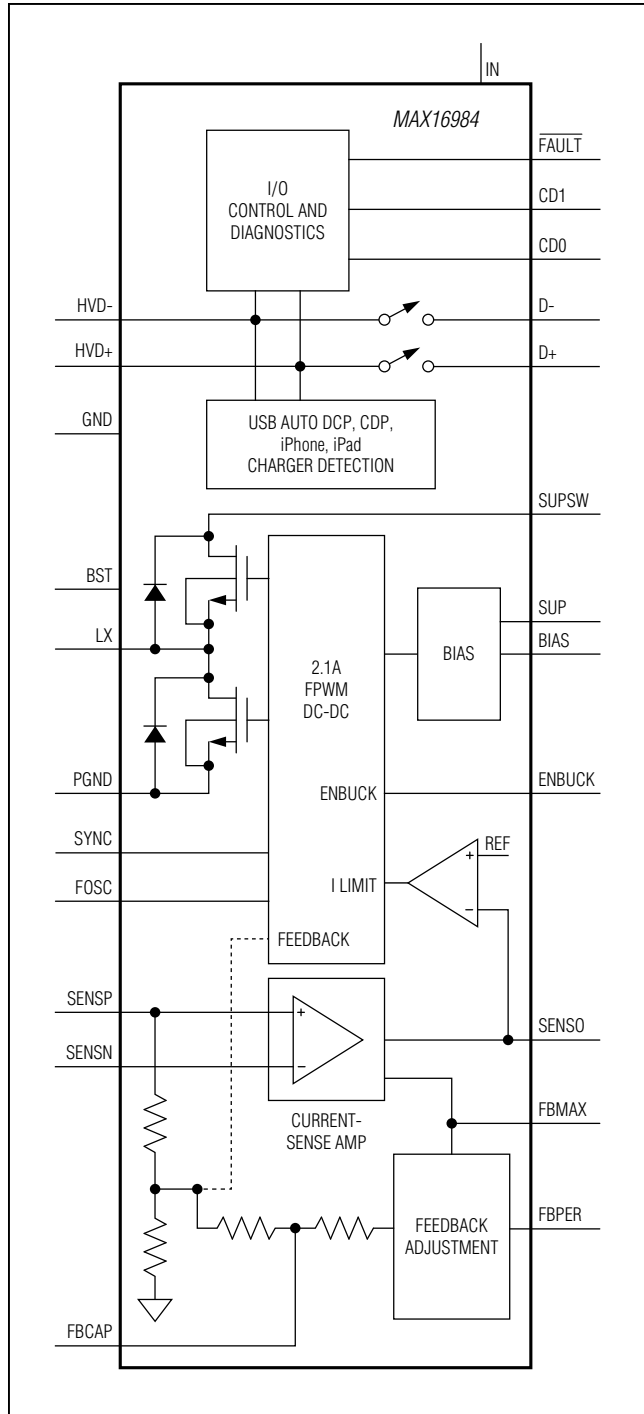

Detailed Description

The MAX16984 combines a 5V/2.1A automotive grade step-down converter, a USB host charger adapter emulator, and USB protection switches. It is designed for high-power USB ports in automotive radio, navigation, connectivity, and USB hub applications.

The USB protection switches provide high-ESD and short-circuit protection for the low-voltage internal data lines of the multimedia processor's USB transceiver and support USB Hi-Speed (480Mbps) and USB Full-Speed (12Mbps) pass-through operation. The MAX16984 features integrated host-charger port-detection circuitry adhering to the USB 2.0 Battery Charging Specification BC1.2 and also includes dedicated bias resistors for iPod/iPhone 1.0A and iPad 2.1A dedicated charging modes.

The high-efficiency step-down DC-DC converter operates from a voltage up to 28V and is protected from load-dump transients up to 42V. The device includes resistor-programmable frequency selection from 220kHz to 2.2MHz to allow optimization of efficiency, noise, and board space based on the application requirements. The converter can deliver up to 2.1A of continuous current at 105°C.

The MAX16984 also includes a high-side current-sense amplifier and configurable feedback-adjustment circuit designed to provide automatic USB voltage adjustment to compensate for voltage drops in captive cables associated with automotive applications.

Power-Up and Enabling

System Enable (IN)

IN is used as the main enable to the MAX16984 and is also used to clamp the D+ and D- pins during an ESD and short-to-battery on the HVD+ and HVD- pins. This clamping protects the downstream USB transceiver. The IN pin contains an overvoltage lockout that disables the data switches if IN is above V_{IN_OVLO} . Bypass IN with a 1µF capacitor and connect it to the same 3.3V supply as shared with the multimedia processor's USB transceiver. If IN is logic-high, the protection switches are enabled and the USB switches operate in one of four modes per the CD0 and CD1 inputs. If IN is at a logic-low level, SUP power consumption is reduced and the device enters a standby low-quiescent level.

Typical Operating Circuit

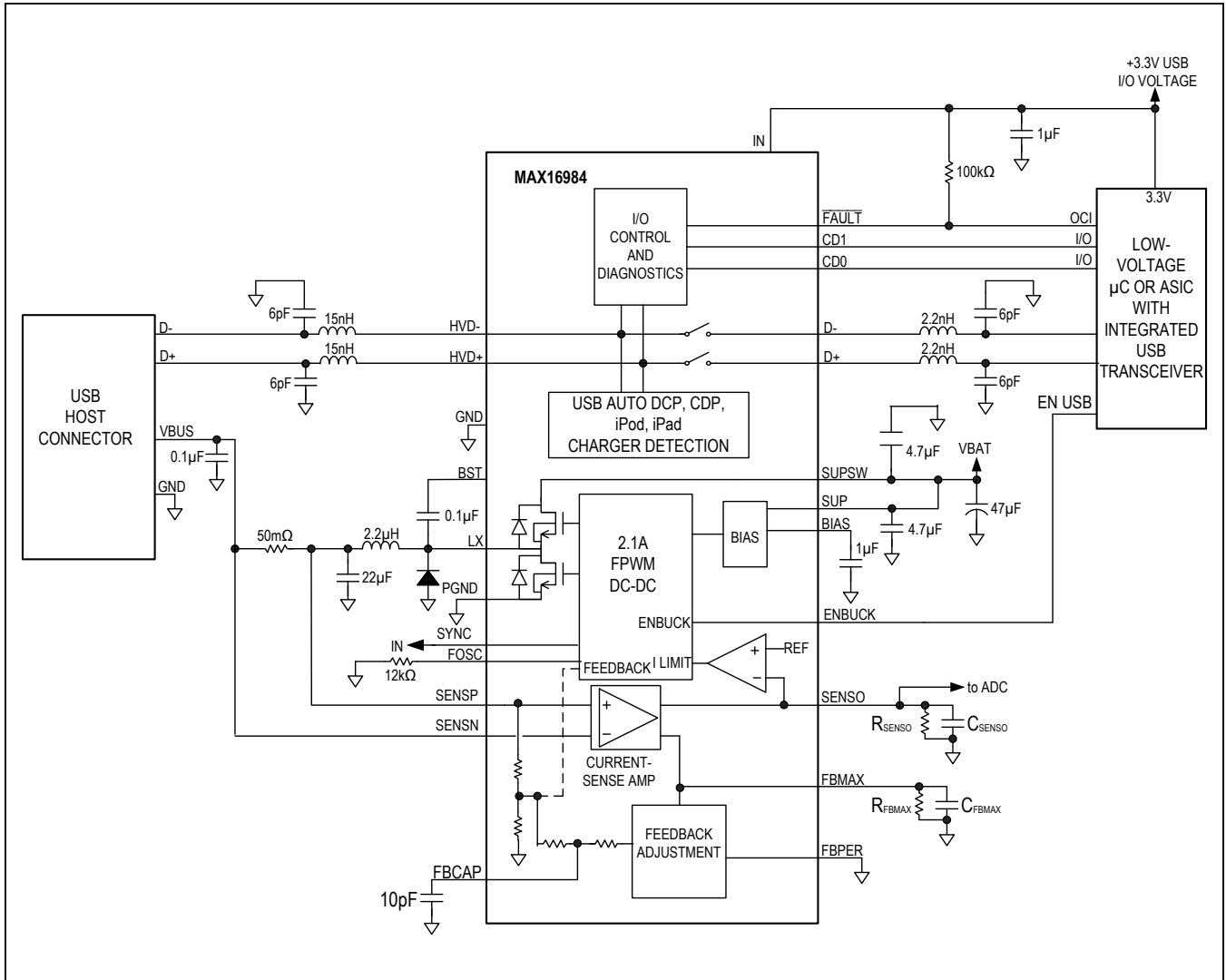

Ordering Information

PART	TEMP RANGE	SPREAD SPECTRUM	PIN-PACKAGE
MAX16984RAGI/VY+*	-40°C to +125°C	Disabled	28 QFND-EP** (SW)
MAX16984SAGI/VY+*	-40°C to +125°C	Enabled	28 QFND-EP** (SW)
MAX16984RATI/V+	-40°C to +125°C	Disabled	28 TQFN-EP**
MAX16984SATI/V+	-40°C to +125°C	Enabled	28 TQFN-EP**

+Denotes a lead(Pb)-free/RoHS-compliant package.

V denotes an automotive qualified part.

*Future product—contact factory for availability.

**EP = Exposed pad.

(SW) = Side wettable.

Chip Information

PROCESS: BiCMOS

Package Information

For the latest package outline information and land patterns (footprints), go to www.maximintegrated.com/packages. Note that a "+", "#", or "-" in the package code indicates RoHS status only. Package drawings may show a different suffix character, but the drawing pertains to the package regardless of RoHS status.

PACKAGE TYPE	PACKAGE CODE	OUTLINE NO.	LAND PATTERN NO.
28 QFND-EP (Side Wettable)	G2855Y+2	21-0563	90-0375
28 TQFN-EP	T2855+6	21-0140	90-0026

Revision History

REVISION NUMBER	REVISION DATE	DESCRIPTION	PAGES CHANGED
0	3/13	Initial release	—
1	7/13	Corrected values/figures, updated <i>Electrical Characteristics</i> table specs, and clarified spread-spectrum information	3–6, 11, 12, 17, 19, 20, 22, 27, 28, 31,
2	12/14	Updated <i>Switching Frequency (FOSC, SYNC)</i> section and <i>Typical Operating Circuit</i>	18, 31
3	4/15	Updated <i>Benefits and Features</i> section, added new Note 1 to <i>Absolute Maximum Ratings</i> and renumbered remaining notes through end of <i>Electrical Characteristics</i> , updated pins 15 and 16 in <i>Pin Description</i> table, updated <i>Tuning of USB Data Lines</i> section and <i>Typical Operating Circuit</i>	1–6, 16, 27, 31

For pricing, delivery, and ordering information, please contact Maxim Direct at 1-888-629-4642, or visit Maxim Integrated's website at www.maximintegrated.com.

Maxim Integrated cannot assume responsibility for use of any circuitry other than circuitry entirely embodied in a Maxim Integrated product. No circuit patent licenses are implied. Maxim Integrated reserves the right to change the circuitry and specifications without notice at any time. The parametric values (min and max limits) shown in the *Electrical Characteristics* table are guaranteed. Other parametric values quoted in this data sheet are provided for guidance.

X-ON Electronics

Largest Supplier of Electrical and Electronic Components

Click to view similar products for [Switching Voltage Regulators](#) category:

Click to view products by [Maxim](#) manufacturer:

Other Similar products are found below :

[FAN53610AUC33X](#) [FAN53611AUC123X](#) [FAN48610BUC33X](#) [FAN48610BUC45X](#) [FAN48617UC50X](#) [R3](#) [430464BB](#) [MIC45116-1YMP-T1](#) [KE177614](#) [MAX809TTR](#) [NCV891234MW50R2G](#) [NCP81103MNTXG](#) [NCP81203PMNTXG](#) [NCP81208MNTXG](#) [NCP81109GMNTXG](#) [SCY1751FCCT1G](#) [NCP81109JMNTXG](#) [AP3409ADNTR-G1](#) [LTM8064IY](#) [LT8315EFE#TRPBF](#) [NCV1077CSTBT3G](#) [XCL207A123CR-G](#) [MPM54304GMN-0002](#) [MPM54304GMN-0003](#) [XDPE132G5CG000XUMA1](#) [DA9121-B0V76](#) [LTC3644IY#PBF](#) [MP8757GL-P](#) [MIC23356YFT-TR](#) [LD8116CGL](#) [HG2269M/TR](#) [OB2269](#) [XD3526](#) [U6215A](#) [U6215B](#) [U6620S](#) [LTC3803ES6#TR](#) [LTC3803ES6#TRM](#) [LTC3412IFE](#) [LT1425IS](#) [MAX25203BATJA/VY+](#) [MAX77874CEWM+](#) [XC9236D08CER-G](#) [ISL95338IRTZ](#) [MP3416GJ-P](#) [BD9S201NUX-CE2](#) [MP5461GC-Z](#) [MPQ4415AGQB-Z](#) [MPQ4590GS-Z](#) [MCP1603-330IMC](#)