



MAX17010 Evaluation Kit

General Description

The MAX17010 evaluation kit (EV kit) is a fully assembled and tested surface-mount printed circuit board (PCB) that provides the voltages and features required for active-matrix, thin-film transistor (TFT), liquid-crystal displays (LCDs). The EV kit contains a step-up switching regulator, a high-speed operational amplifier (op amp), and eight high-voltage level-shifting buffers for scan-driver applications.

The EV kit operates from a DC supply voltage of 1.8V to 5.5V. The step-up switching regulator is configured for a 8.5V output providing at least 300mA from a 2.7V input. The positive charge pump is configured for a 23V output providing at least 20mA. The negative charge pump is configured for a -7.5V output providing at least 20mA. The op amp is configured for 4.25V, capable of providing up to ± 150 mA peak. The high-voltage, level-shifting scan driver buffers eight logic inputs and shifts them to a desired level to drive TFT-LCD row logic.

The MAX17010 EV kit demonstrates low quiescent current and high efficiency (> 85%) for maximum battery life. Operation at 1.2MHz allows the use of tiny surface-mount components. The MAX17010 thin QFN package (0.8mm maximum height), with low-profile external components, allows this circuit to be less than 1.2mm high.

Features

- ◆ 1.8V to 5.5V Input Range
- ◆ Output Voltages
 - 8.5V Output at 300mA from a 2.7V Input (Step-Up Switching Regulator)
 - 23V Output at 20mA (Positive Charge Pump)
 - 7.5V Output at 20mA (Negative Charge Pump)
 - 4.25V High-Current Op Amp Output
- ◆ Resistor-Adjustable Switching-Regulator and Op Amp Output Voltage
- ◆ Eight 30V to -10V High-Voltage Level-Shifting Buffers
- ◆ Greater than 85% Efficiency (Step-Up Switching Regulator)
- ◆ 1.2MHz Step-Up Switching Frequency
- ◆ 1.2mm Low-Profile Surface-Mount Components
- ◆ Fully Assembled and Tested

Ordering Information

PART	TEMP RANGE	IC PACKAGE
MAX17010EVKIT+	0°C to +70°C*	40 TQFN (5mm x 5mm x 0.8mm)

+Denotes a lead-free and RoHS-compliant EV kit.

*This limited temperature range applies to the EV kit PCB only. The MAX17010 IC temperature range is -40°C to +85°C.

Component List

DESIGNATION	QTY	DESCRIPTION
C1	1	10 μ F \pm 20%, 6.3V X5R ceramic capacitor (0603) Murata GRM188R60J106M TDK C1608X5R0J106M or equivalent
C2	0	Not installed, ceramic capacitor (1206)
C3	1	0.22 μ F \pm 1%, 10V X7R ceramic capacitor (0603) TDK C1608X7R1C224K KEMET C0603C224K4RAC or equivalent
C4, C6–C15	11	0.1 μ F \pm 10%, 50V X7R ceramic capacitors (0603) Murata GRM188R71H104K TDK C1608X7R1H104K or equivalent

DESIGNATION	QTY	DESCRIPTION
C5	1	220pF \pm 10%, 50V X7R ceramic capacitor (0603) Murata GRM188R71H221K TDK C1608X7R1H221K or equivalent
C16, C17	2	4.7 μ F \pm 10%, 16V X5R ceramic capacitors (1206) Murata GRM319R61C475KA88D TDK C3216X5R1C475K
C18, C19, C20	0	Not installed, ceramic capacitors (0603)
C21–C28	8	100pF \pm 5%, 50V C0G ceramic capacitors (0603) Murata GRM1885C1H101J TDK C1608C0G1H101J or equivalent
C29	0	Not installed, electrolytic capacitor (6.3mm x 5mm)



MAX17010 Evaluation Kit

Component List (continued)

DESIGNATION	QTY	DESCRIPTION
D1	1	30V, 1A Schottky diode (S-Flat) Nihon EP10QY03 Toshiba CRS02(TE85L,Q)
D2, D3, D4	3	100V, 200mA dual diodes (SOT23) Fairchild MMBD4148SE (Top Mark: D4) Central CMPD7000 lead free (Top Mark: C5C)
JU1	1	2-pin header
L1	1	3.6 μ H, 1.8A power inductor Sumida CMD6D11BHPNP-3R6MC
R1	1	0 Ω resistor (0603)
R2, R5, R6	3	200k Ω \pm 1% resistors (0603)

DESIGNATION	QTY	DESCRIPTION
R3	1	34k Ω \pm 1% resistor (0603)
R4	1	100k Ω \pm 1% resistor (0603)
R7–R15	9	100k Ω \pm 5% resistors (0603)
R16, R17, R20	0	Not installed, resistors—shorted by PC trace (0603)
R18, R19	0	Not installed, resistors—shorted by PC trace (0402)
SW1, SW2	2	8-position, low-profile DIP switches
U1	1	MAX17010TEL+ (40-pin TQFN, 5mm x 5mm)
A1–A8, Y1–Y8	0	Not installed, test points
—	1	PCB: MAX17010 Evaluation Kit+

Component Suppliers

SUPPLIER	PHONE	WEBSITE
Central Semiconductor Corp.	631-35-1110	www.centalsemi.com
Fairchild Semiconductor	888-522-5372	www.fairchildsemi.com
Murata Mfg. Co., Ltd.	770-36-1300	www.murata.com
Nihon Inter Electronics Corp.	81-3-3343-3411	www.niec.co.jp
SANYO North America Corp.	619-661-6322	www.sanyodevice.com
Sumida Corp.	847-545-6700	www.sumida.com
TDK Corp.	847-803-6100	www.component.tdk.com
Toshiba America Electronic Components, Inc.	949-455-2000	www.toshiba.com/taec

Note: Indicate that you are using the MAX17010 when contacting these component suppliers.

Quick Start

Recommended Equipment

- 1.8V to 5.5V, 2A DC power supply
- Voltmeter

Procedure

The MAX17010 EV kit is fully assembled and tested. Follow the steps below to verify board operation.

Caution: Do not turn on the power supply until all connections are completed.

- 1) Verify that there is a shunt installed across jumper JU1.
- 2) Verify that SW1 and SW2 eight-position DIP switches are in the ON position.

- 3) Connect the positive terminal of the power supply to the VIN pad. Connect the negative terminal of the power supply to the GND pad.
- 4) Turn on the power supply and verify that the step-up switching regulator output (VMAIN) is 8.5V.
- 5) Verify that the gate-on supply (GON) is approximately 23V.
- 6) Verify that the gate-off supply (GOFF) is approximately -7.5V.
- 7) Verify that the output of the high-speed op amp (VCOM) is 4.25V.
- 8) Verify that the outputs of the high-voltage level-shifting buffers are approximately 23V (= GON).

For instructions on selecting the step-up switching regulator feedback and op amp divider resistors for other output voltages, see the *Output Voltage Selection* section.

MAX17010 Evaluation Kit

Evaluates: MAX17010

Detailed Description

The MAX17010 EV kit contains a step-up switching regulator, a positive two-stage charge pump, a negative single-stage charge pump, a high-speed op amp, and eight high-voltage level-shifting buffers for scan-driver applications. The EV kit operates from a DC power supply between 1.8V and 5.5V that provides at least 2A.

As configured, the step-up switching regulator (VMAIN) generates an 8.5V output and provides at least 200mA from a 1.8V input. It also provides at least 300mA from a 2.7V input and 700mA from a 5.5V input. The step-up switching-regulator output voltage can be adjusted up to 18V with different feedback resistors (see the *Output Voltage Selection* section).

The GON consists of two positive charge-pump stages to generate approximately 23V and can provide greater than 20mA. The GOFF consists of a single negative charge-pump stage to generate approximately -7.5V and can provide greater than 20mA. Loading GON and GOFF reduces the available VMAIN current proportionally.

The op amp output (VCOM) is set to 4.25V and can source or sink peak current up to 150mA. The output can be reconfigured to other voltages with voltage-divider resistors (see the *Output Voltage Selection* section).

The eight logic-level to high-voltage level-shifting buffers can buffer eight logic inputs (A1–A8) and shift them to a desired level (Y1–Y8) to drive TFT-LCD row logic. Each buffer outputs the voltage on the GOFF pin (set to the voltage on the GOFF pad through R20) when its respective input is logic-high. Each buffer (Y1–Y6) outputs the voltage at GON1 (set to GON through R16) when its respective input is logic-high. Similarly, Y7 and Y8 output the voltage at GON2 (set to GON through R17).

The eight switches within SW1 are used to select logic levels on A1–A8 for testing purposes. Set each switch open when driving A1–A8 with external logic. The eight switches within SW2 are used to connect capacitive loads to Y1–Y8 for testing purposes. Set each switch open when Y1–Y8 drive an actual panel load.

Jumper Selection

The MAX17010 EV kit incorporates a jumper (JU1) to control the SHDN pin. See Table 1 for jumper JU1 functions.

Table 1. Jumper JU1 Functions

SHUNT POSITION	SHDN PIN	EV KIT OUTPUTS
Installed*	$\overline{\text{SHDN}}$ is tied to PIN	Outputs enabled (VMAIN = 8.5V)
Not installed	$\overline{\text{SHDN}}$ is tied to ground through R7	Outputs disabled (VMAIN ≈ PIN)

*Default position.

Output Voltage Selection Step-Up Switching-Regulator Output Voltage (VMAIN)

The MAX17010 EV kit's step-up switching-regulator output (VMAIN) is set to 8.5V by feedback resistors R2 and R3. To generate output voltages other than 8.5V (up to 18V), select different external voltage-divider resistors, R2 and R3.

Note that changing the VMAIN voltage setting changes the GON and GOFF charge-pump output voltages. The voltage range on GOFF is limited to -10V and the voltage range of GON1 and GON2 is limited to 30V. If VMAIN is set for more than 10V, PCB traces shorting R16, R17, and R20 should be cut, disconnecting GON1, GON2, and GOFF from the charge-pump outputs. If operation of the high-voltage buffers is desired, power GON1, GON2, and GOFF from an external supply or postregulated charge-pump outputs.

In addition, output capacitors C16 and C17 are rated for 16V. To set VMAIN for greater than 16V, use higher voltage-rated capacitors. Refer to the *Main Step-Up Regulator, Output Voltage Selection* section in the MAX17010 data sheet for instructions on selecting resistors R2 and R3.

Op Amp Output Voltage (VCOM)

The MAX17010 EV kit's op amp is configured as a unity-gain buffer by the PCB trace shorting R19 between NEG and VCOM. The voltage at the noninverting input (POS) is set to half of VMAIN by voltage-divider resistors R5 and R6. To set VCOM to other voltages (up to VMAIN), select different divider resistors.

MAX17010 Evaluation Kit

Evaluates: MAX17010

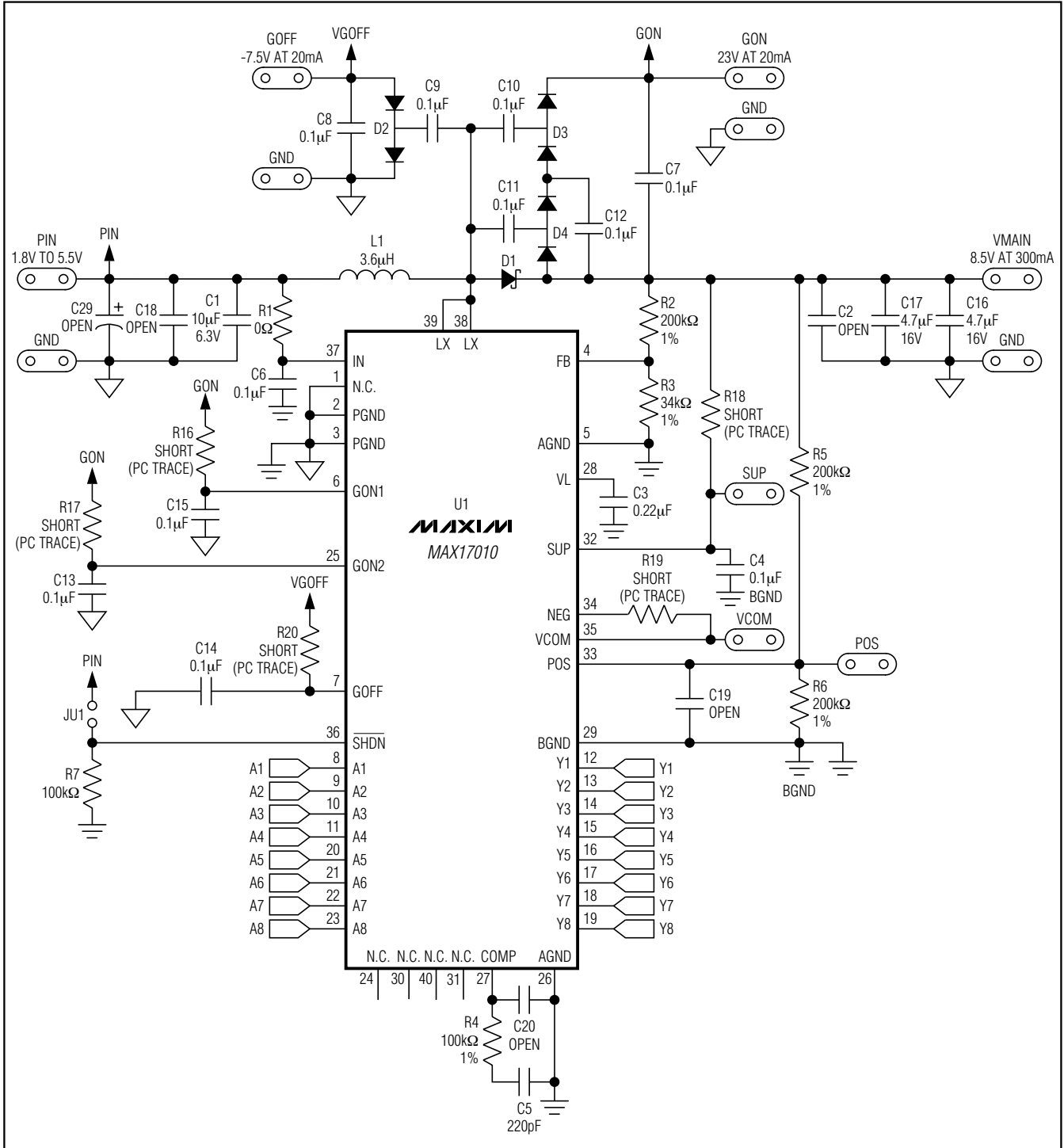

Figure 1a. MAX17010 EV Kit Schematic (Sheet 1 of 2)

MAX17010 Evaluation Kit

Evaluates: MAX17010

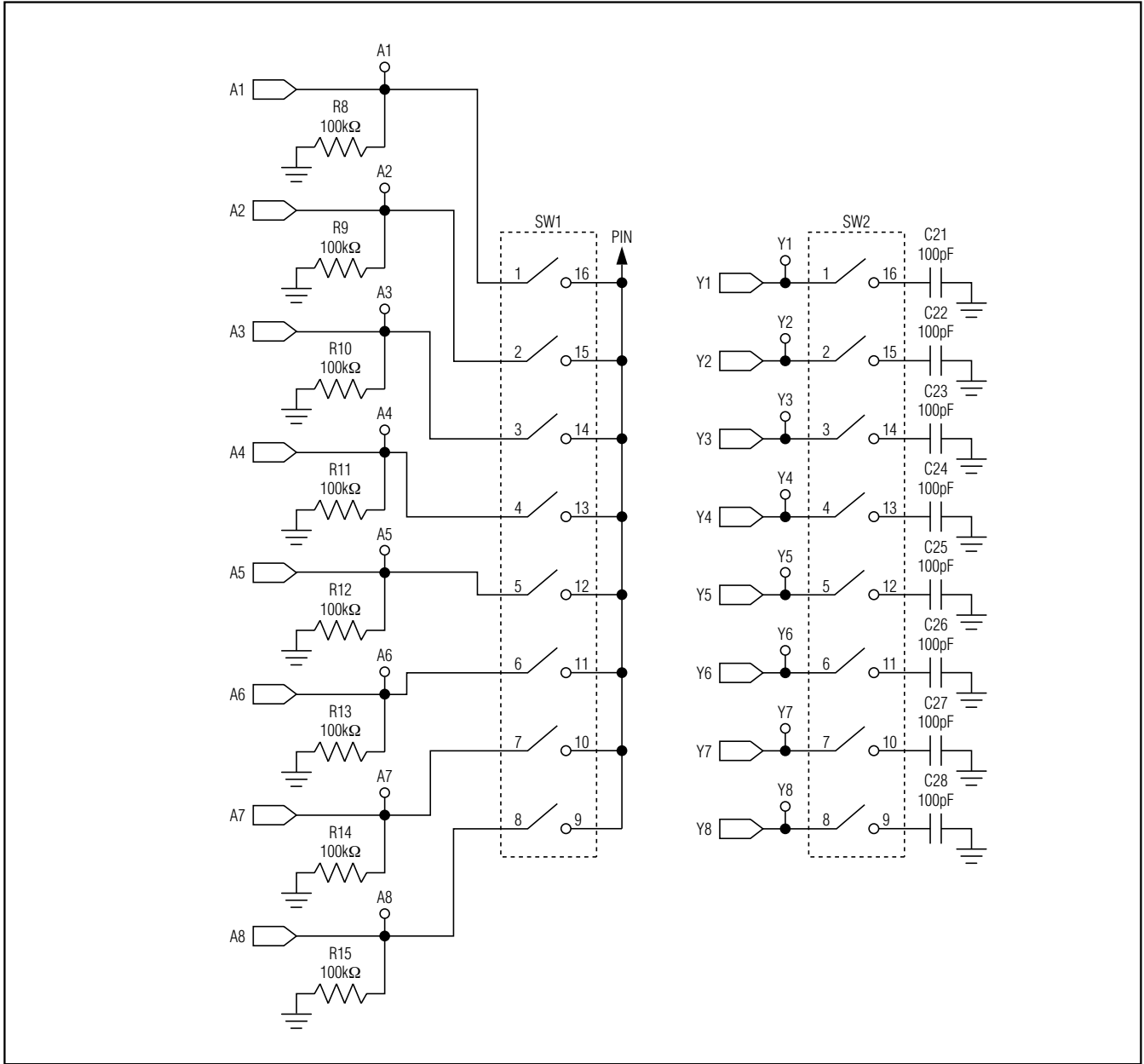

Figure 1b. MAX17010 EV Kit Schematic (Sheet 2 of 2)

MAX17010 Evaluation Kit

Evaluates: MAX17010

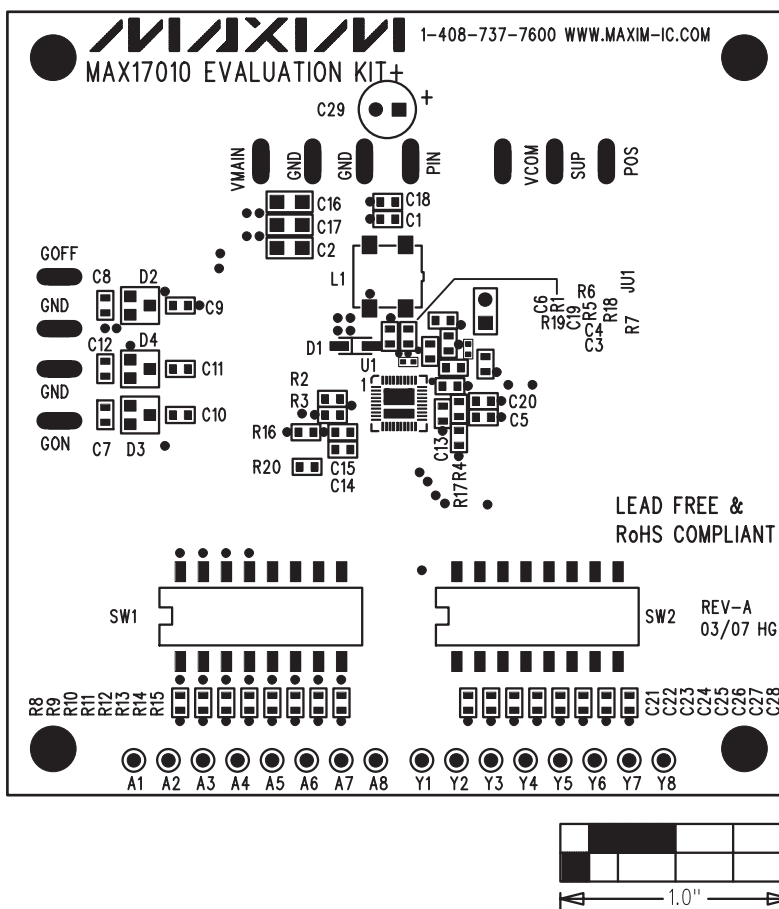

Figure 2. MAX17010 EV Kit Component Placement Guide—Component Side

MAX17010 Evaluation Kit

Evaluates: MAX17010

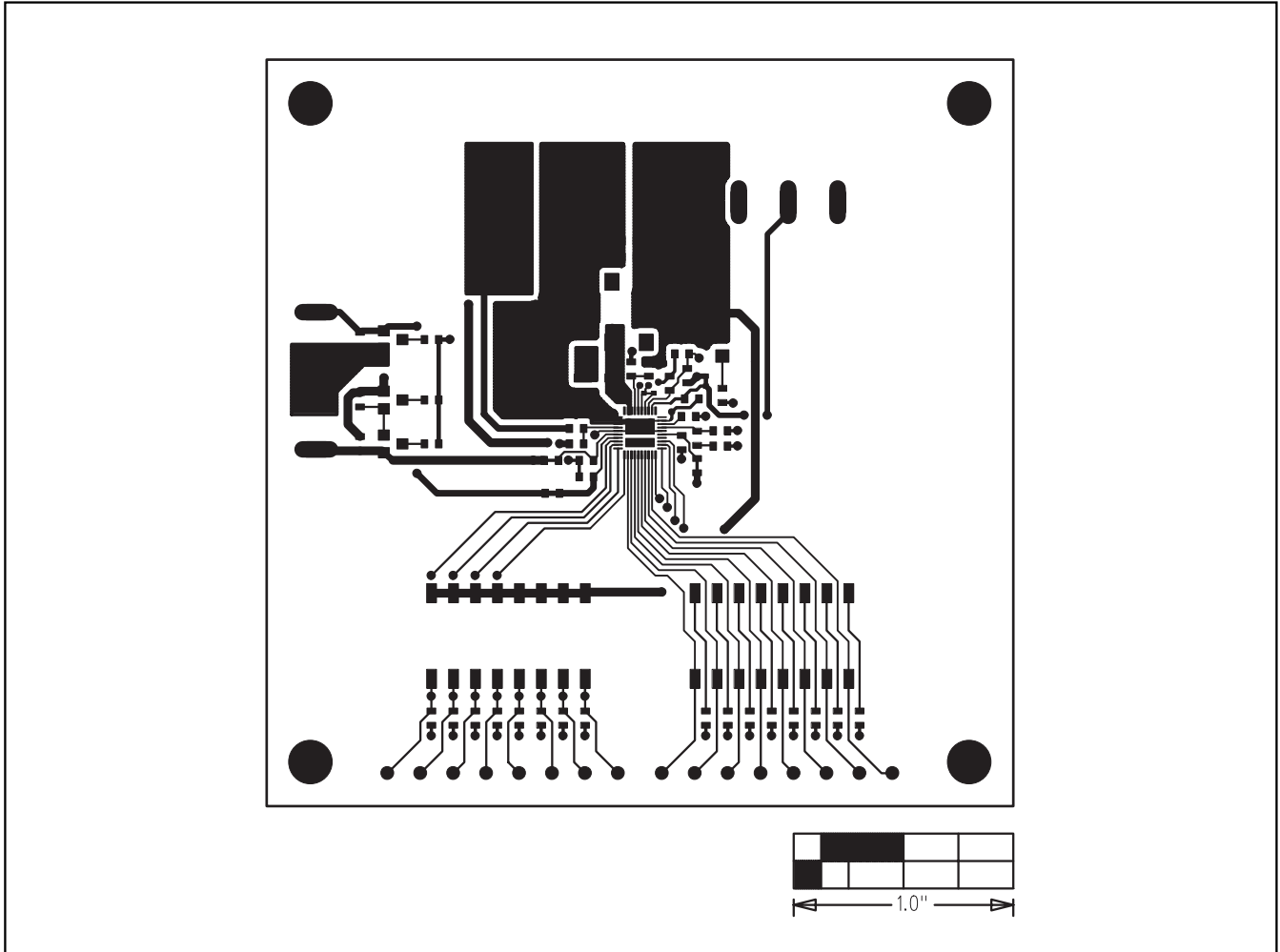

Figure 3. MAX17010 EV Kit PCB Layout—Component Side

MAX17010 Evaluation Kit

Evaluates: MAX17010

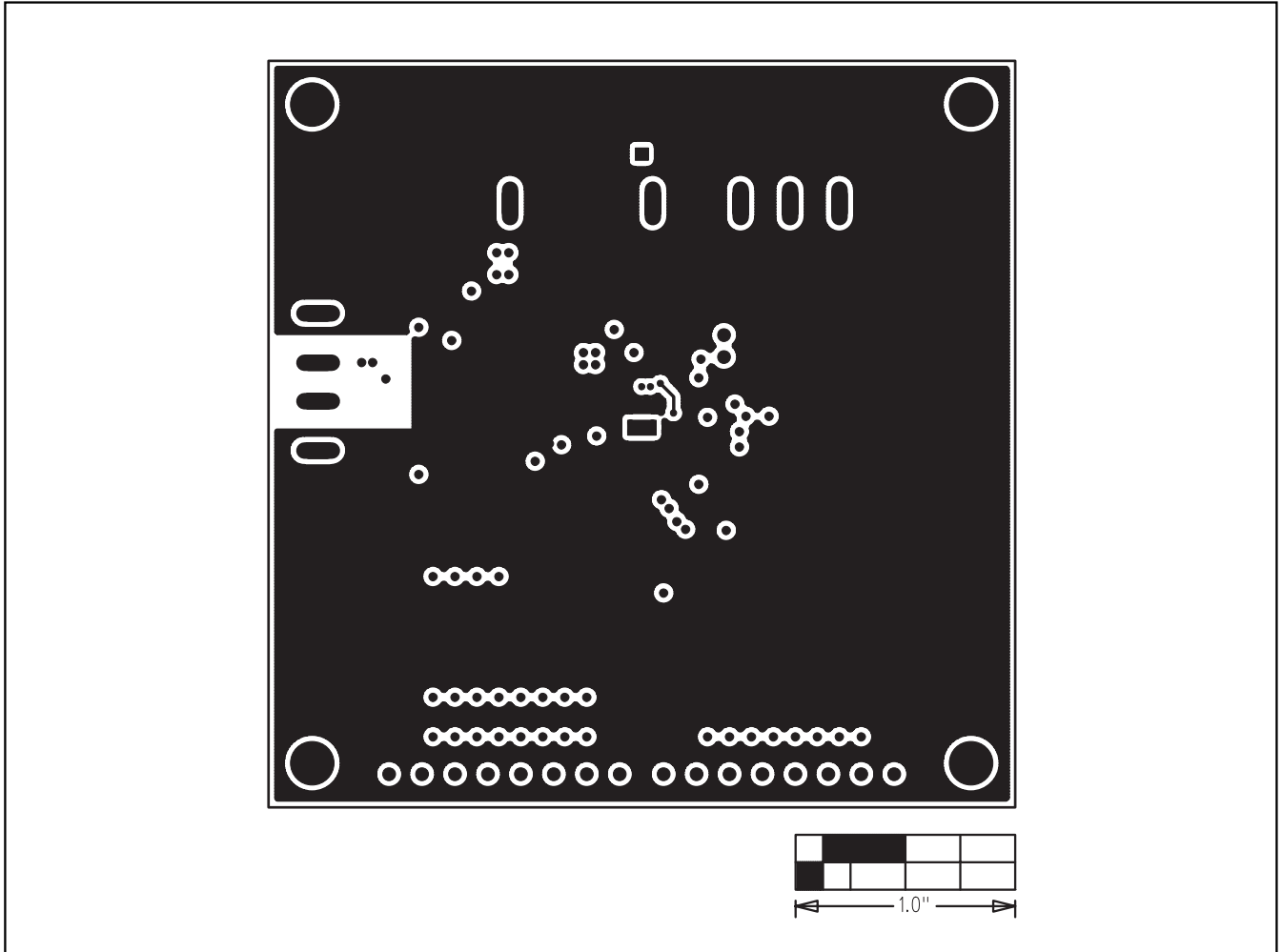

Figure 4. MAX17010 EV Kit PCB Layout—GND Layer 2

MAX17010 Evaluation Kit

Evaluates: MAX17010

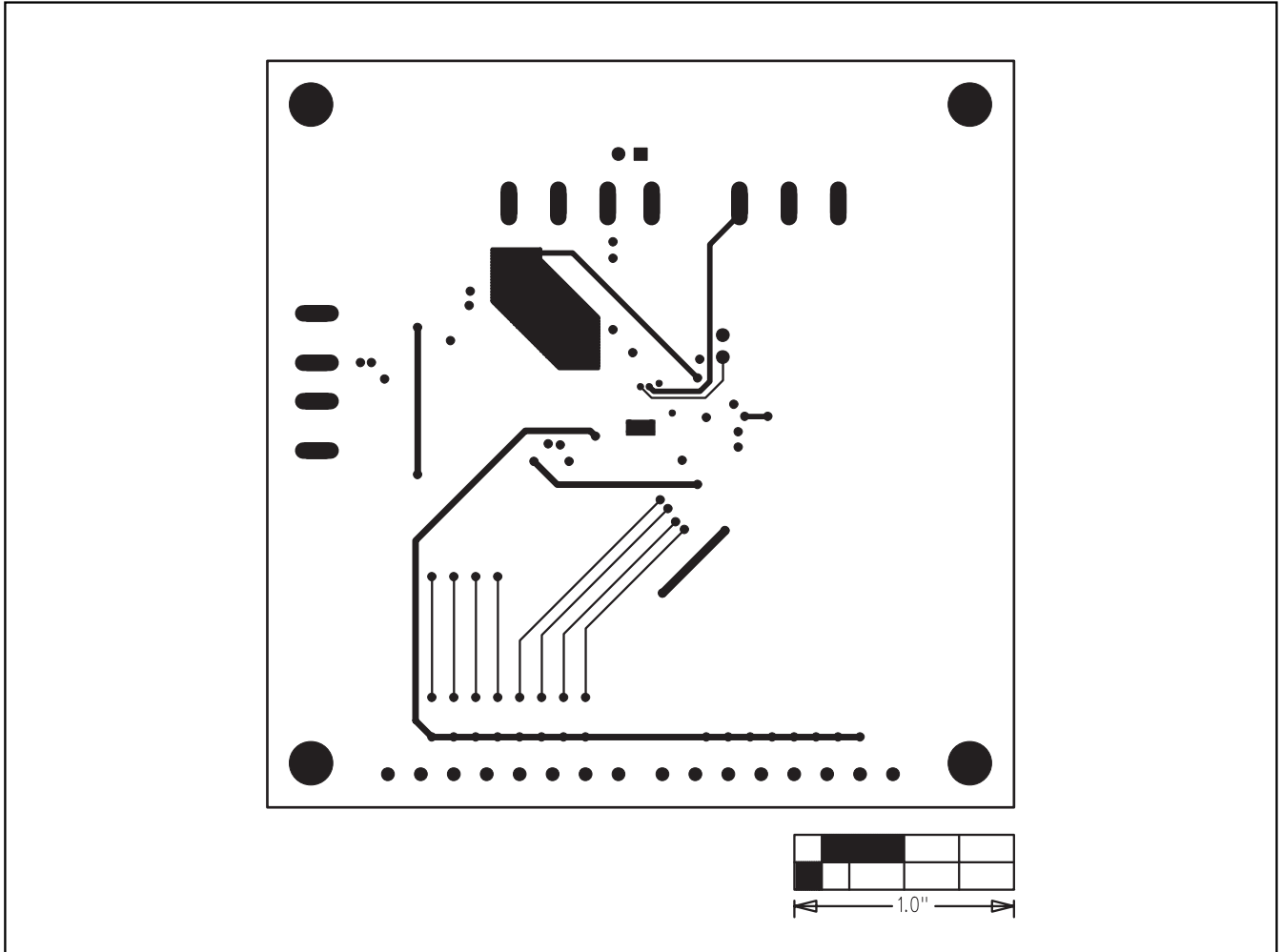

Figure 5. MAX17010 EV Kit PCB Layout—Signal Layer 3

MAX17010 Evaluation Kit

Evaluates: MAX17010

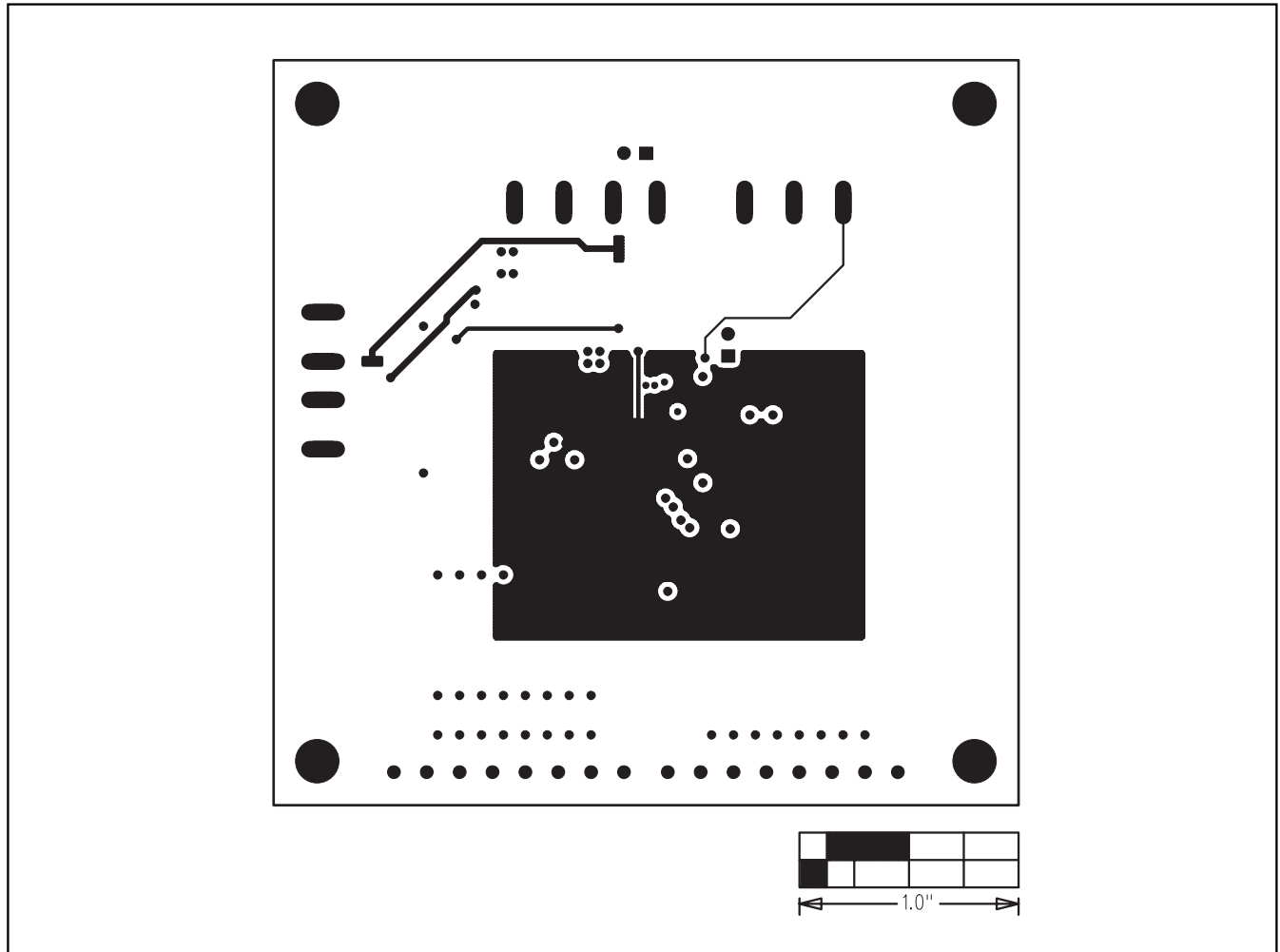

Figure 6. MAX17010 EV Kit PCB Layout—Solder Side

Maxim cannot assume responsibility for use of any circuitry other than circuitry entirely embodied in a Maxim product. No circuit patent licenses are implied. Maxim reserves the right to change the circuitry and specifications without notice at any time.

10 **Maxim Integrated Products, 120 San Gabriel Drive, Sunnyvale, CA 94086 408-737-7600**

© 2007 Maxim Integrated Products

MAXIM is a registered trademark of Maxim Integrated Products, Inc.

X-ON Electronics

Largest Supplier of Electrical and Electronic Components

Click to view similar products for [Power Management IC Development Tools](#) category:

Click to view products by [Maxim](#) manufacturer:

Other Similar products are found below :

[EVB-EP5348UI](#) [MIC23451-AAAYFL EV](#) [MIC5281YMME EV](#) [124352-HMC860LP3E](#) [DA9063-EVAL](#) [ADP122-3.3-EVALZ](#) [ADP130-0.8-EVALZ](#) [ADP130-1.8-EVALZ](#) [ADP1740-1.5-EVALZ](#) [ADP1870-0.3-EVALZ](#) [ADP1874-0.3-EVALZ](#) [ADP199CB-EVALZ](#) [ADP2102-1.25-EVALZ](#) [ADP2102-1.875EVALZ](#) [ADP2102-1.8-EVALZ](#) [ADP2102-2-EVALZ](#) [ADP2102-3-EVALZ](#) [ADP2102-4-EVALZ](#) [AS3606-DB](#) [BQ25010EVM](#) [BQ3055EVM](#) [ISLUSBI2CKIT1Z](#) [LP38512TS-1.8EV](#) [EVAL-ADM1186-1MBZ](#) [EVAL-ADM1186-2MBZ](#) [ADP122UJZ-REDYKIT](#) [ADP166Z-REDYKIT](#) [ADP170-1.8-EVALZ](#) [ADP171-EVALZ](#) [ADP1853-EVALZ](#) [ADP1873-0.3-EVALZ](#) [ADP198CP-EVALZ](#) [ADP2102-1.0-EVALZ](#) [ADP2102-1-EVALZ](#) [ADP2107-1.8-EVALZ](#) [ADP5020CP-EVALZ](#) [CC-ACC-DBMX-51](#) [ATPL230A-EK](#) [MIC23250-S4YMT EV](#) [MIC26603YJL EV](#) [MIC33050-SYHL EV](#) [TPS60100EVM-131](#) [TPS65010EVM-230](#) [TPS71933-28EVM-213](#) [TPS72728YFFEVM-407](#) [TPS79318YEQEVM](#) [UCC28810EVM-002](#) [XILINXPWR-083](#) [LMR22007YMINI-EVM](#) [LP38501ATJ-EV](#)