

## General Description

The MAX17233 evaluation kit (EV kit) is a fully assembled and tested application circuit board for the MAX17233 high-voltage, dual synchronous step-down controller. The EV kit is set up to provide 5V and 3.3V from an input voltage ranging from 6V to 36V. Each buck rail can deliver up to 5A load current. The EV kit's switching frequency is set at 2.2MHz for both buck converters. Various jumpers are provided to help evaluate features of the MAX17233 IC.

## Features

- Dual, Synchronous Step-Down Controllers Operate at 180° Out-of-Phase to Reduce Switching Noise
- 6V to 36V Wide Input Supply Range
- Buck Output Voltage: 5V and 3.3V Fixed/Adjustable Between 1V and 10V
- Current-Mode Controllers with Forced-PWM and Skip Modes
- Resistor-Configurable Frequency Between 1MHz and 2.2MHz
- 89% Peak Efficiency @ 6V Input in Skip-Mode
- FSYNC Input and Power-Good Output
- Proven 4-Layer 2oz Copper PCB Layout
- Demonstrates 2800mil x 1300mil Solution Size
- Fully Assembled and Tested

## EV Kit Contents

- MAX17233 EV Kit Board

## Quick Start

### Recommended Equipment

- MAX17233 EV kit
- 6V to 36V, 15A power supply
- Two voltmeters
- Two electronic loads capable of sinking 5A each

### Procedure

The EV kit is fully assembled and tested. Follow the steps below to activate the board. **Caution: Do not turn on the power supply until all connections are completed.**

- 1) Verify that all jumpers are in their default configurations according to [Table 1](#).
- 2) Connect the positive and negative terminals of the power supply to the VBAT and PGND banana jacks, respectively.
- 3) Connect the positive terminal of the first electronic load to the V<sub>OUT1</sub> banana jack. Connect the ground terminal of the electronic load to the corresponding PGND banana jack.
- 4) Connect the positive terminal of the second electronic load to the V<sub>OUT2</sub> banana jack. Connect the ground terminal of the electronic load to the corresponding PGND banana jack.
- 5) Set the power-supply voltage to 14V.
- 6) Turn on the power supply.
- 7) Enable the electronic loads.
- 8) Verify that V<sub>OUT1</sub> is approximately 5V.
- 9) Verify that V<sub>OUT2</sub> is approximately 3.3V.

[Ordering Information](#) appears at end of data sheet.

**Table 1. Default Jumper Settings**

JUMPER	DEFAULT SHUNT POSITION	FUNCTION
JU1, JU2	1-2	Buck outputs enabled.
JU6	1-2	Forced-PWM mode.
JU7	1-2	Switches to EXTVCC. Internal regulator disabled.
JU8, JU9	Installed	PGOOD_ pulls up to BIAS when OUT_ is in regulation.

**Detailed Description of Hardware**

The MAX17233 EV kit, which evaluates the MAX17233 high-voltage, dual synchronous step-down controller, can supply up to two rails. The EV kit includes two current-mode buck outputs that are fixed to 5V and 3.3V, or configurable from 1V to 10V with external resistor-dividers. The current capability is 5A per rail. Both outputs are current limited and can be controlled independently through their respective enable inputs EN\_.

**Switching Frequency/External Synchronization**

The EV kit switching frequency can be adjusted from 1MHz to 2.2MHz by changing the FOSC resistor R136. The EV kit can also be synchronized to an external clock by connecting the external clock signal to the FSYNC test point and AGND. Refer to the *Switching Frequency/ External Synchronization* section of the MAX17233 IC data sheet for more details.

**Enable Control**

The EV kit features jumper JU1 to independently control the enable input of V<sub>OUT1</sub> and jumper JU2 to control the enable input of V<sub>OUT2</sub>. Connect the EN\_ pin to V<sub>BAT</sub> (pins 1-2) to enable V<sub>OUT\_</sub>. Connect the EN\_ pin to PGND (pins 2-3) to disable V<sub>OUT\_</sub>. See [Table 2](#).

**Mode of Operation**

The EV kit features jumper JU6 to configure the mode switch-control input ([Table 3](#)). Drive FSYNC high (pins 1-2 of JU6) to enable forced-PWM mode. Drive FSYNC low (pins 2-3 of JU6) to enable skip mode under light loads.

**EXTVCC Switchover Comparator**

The internal linear regulator can be bypassed by connecting an external supply (3.1V to 5.2V) or the output of one of the buck converters to EXTVCC. BIAS internally switches to EXTVCC and the internal linear regulator turns off. If V<sub>EXTVCC</sub> drops below V<sub>TH,EXTVCC</sub> = 3.1V(min), the internal regulator enables and switches back to BIAS. See [Table 4](#).

**Table 2. Enable Control (JU1, JU2)**

SHUNT POSITION	EN_ PIN	VOUT_
1-2*	Connected to VBAT	Enabled
2-3	Connected to PGND	Disabled

\*Default configuration.

**Table 3. Mode of Operation (JU6)**

SHUNT POSITION	FSYNC PIN	MODE
1-2*	Connected to BIAS	Forced-PWM mode
2-3	Connected to AGND	Skip mode

\*Default configuration.

**Table 4. EXTVCC (JU7)**

SHUNT POSITION	EXTVCC PIN	BIAS
1-2	Connected to VOUT1	Switches to EXTVCC. Internal regulator disabled.
1-3*	Connected to PGND	Internal regulator enabled.
1-4	Connected to VOUT2	Switches to EXTVCC. Internal regulator disabled.

\*Default configuration.

**Buck Output Monitoring (PGOOD\_)**

The EV kit provides two power-good output test points (PGOOD1 and PGOOD2) to monitor the status of the two buck outputs (OUT1 and OUT2). Each PGOOD\_ goes high (high impedance) when the corresponding regulator output voltage is in regulation. Each PGOOD\_ goes low when the corresponding regulator output voltage drops below 15% (typ) or rises above 10% (typ) of its nominal regulated voltage. PGOOD\_ asserts low during soft-start

and in shutdown. PGOOD\_ becomes high impedance when OUT\_ is in regulation. To obtain a logic signal, pull up PGOOD\_ to BIAS by installing shunts on JU8 and JU9.

### Setting the Output Voltage in Buck Converters

To externally adjust the output voltage OUT1 between 1V and 10V, remove R122. Connect a resistive divider from the output OUT1 to FB1 to AGND. Place appropriate resistors in positions R119 and R120 according to the following equation:

$$R119 = R120 \left[ \left( \frac{V_{OUT1}}{V_{FB1}} \right) - 1 \right]$$

where  $V_{FB1} = 1V$  (typ).

To externally adjust the output voltage OUT2 between 1V and 10V, remove R134. Connect a resistive divider from the output OUT2 to FB2 to AGND. Place appropriate resistors in positions R131 and R132 according to the following equation:

$$R131 = R132 \left[ \left( \frac{V_{OUT2}}{V_{FB2}} \right) - 1 \right]$$

where  $V_{FB2} = 1V$  (typ).

### Evaluating the MAX17232 on the MAX17233 EV Kit

The MAX17233 EV kit can be modified to operate the MAX17232. The MAX17232 operates at a switching frequency of 400kHz, which requires a change in the following components:

- 1) Replace U1 with the MAX17232 IC.
- 2) Replace R136 ( $R_{FOSC}$ ) with 80.6k $\Omega$  to achieve 400kHz switching frequency.
- 3) Replace the buck inductors (L7, L8) with a 6.8 $\mu$ H 7A inductor.

Contact Technical Support at [www.maximintegrated.com/support](http://www.maximintegrated.com/support) for any further questions.

## Component Suppliers

SUPPLIER	WEBSITE
NXP	www.nxp.com
Fairchild Semiconductor	www.fairchildsemi.com
IRC, Inc.	www.ircft.com
Murata Electronics North America, Inc.	www.murata.com
Panasonic Corp.	www.panasonic.com
TDK Corp.	www.component.tdk.com
Vishay	www.vishay.com

**Note:** Indicate that you are using the MAX17233 when contacting these component suppliers.

## Component Information, PCB Layout, and Schematic

See the following links for component information, PCB layout diagrams, and schematic.

- [MAX17233 EV BOM](#)
- [MAX17233 EV PCB Layout](#)
- [MAX17233 EV Schematic](#)
- [MAX17233 EV Minimal Component Schematic](#)

## Ordering Information

PART	TYPE
MAX17233EVKIT#	EV Kit

#Denotes RoHS compliant.

### Revision History

REVISION NUMBER	REVISION DATE	DESCRIPTION	PAGES CHANGED
0	2/16	Initial release	—

For pricing, delivery, and ordering information, please contact Maxim Direct at 1-888-629-4642, or visit Maxim Integrated's website at [www.maximintegrated.com](http://www.maximintegrated.com).

*Maxim Integrated cannot assume responsibility for use of any circuitry other than circuitry entirely embodied in a Maxim Integrated product. No circuit patent licenses are implied. Maxim Integrated reserves the right to change the circuitry and specifications without notice at any time.*

## MAX17233EVKIT#: Rev A

Item	Component Description	Qty	Reference Designators	Manufacturer	Part Number
0001	63MIL DRILL SIZE test point (BLK)	1	AGND	Keystone Electronics	5011
0002	63MIL DRILL SIZE test points (RED)	3	FSYNC, PGOOD1 TEST, PGOOD2 TEST	Keystone Electronics	5010
0003	0.1uF±10%, 50V X7R ceramic capacitors (0603)	5	C1, C2, C3, C75, C83	Murata	GRM188R7
0004	47uF ±20%, 16V X7R ceramic capacitors (2220)	4	C76, C77, C84, C85	TDK	CGA9N3X7
0005	4700pF ±10% 50V X7R ceramic capacitors (0402)	2	C78, C86	Murata	GRM155R7
0006	22pF ±5% 50V C0G ceramic capacitor (0402)	1	C79	Murata	GRM1555C0
0007	6.8uF ±10%, 16V X7R ceramic capacitor (1206)	1	C81	TDK	C3216X7R
0008	2.2uF ±10%, 10V X7R ceramic capacitor (0603)	1	C82	Murata	GRM188R7
0009	33pF ±5% 50V C0G ceramic capacitor (0402)	1	C87	Murata	GRM1555C0
0010	47uF, 50V ±20% aluminum electrolytic capacitor (8.0x6.2mm)	1	C88	Panasonic	EEEEFK1H4
0011	4.7uF±10%, 50V X7R ceramic capacitors (1210)	6	C90-C93, C97, C116	Murata	GCM32ER7
0012	200mA, 30V Schottky diodes (SOT23)	2	D20, D21	Fairchild	BAT54
0013	5A, 40V Schottky Diodes (SOD-128)	2	D22, D23	NXP	PMEG4050
0014	3-pin headers (CUT TO FIT)	3	JU1, JU2, JU6	SULLINS	PEC36SAA
0015	4-pin header (CUT TO FIT)	1	JU7	SULLINS	PEC36SAA
0016	2-pin headers (CUT TO FIT)	2	JU8, JU9	SULLINS	PEC36SAA
0017	2.2uH 12A power inductors	2	L7, L8	Vishay	IHLP4040D
0018	40V, 7.6A N-channel MOSFETs (8-SOIC)	4	Q13-Q16	Fairchild	FDMC8015
0019	JACKS, BANNANA, UNINSULATED, PANEL MOUNT	6	PGND (3x), VBAT, VOUT1, VOUT2	JOHNSON	108-0740-0
0020	1kΩ ±5% resistors (0603)	2	R1, R2	Any	Any
0021	0Ω ± 5% resistors (0603)	8	R113-R115, R122, R125-R127, R134	Any	Any
0022	0.012Ω, ±1%, 1W sense resistors (2010)	2	R116, R128	IRC	LRF2010LF
0023	22.1kΩ ±1% resistor (0603)	1	R123	Any	Any
0024	1Ω ±5%, resistor (0603)	1	R124	Any	Any
0025	14kΩ ±1% resistor (0603)	1	R135	Any	Any
0026	13.7kΩ 1% resistor (0603)	1	R136	Any	Any
0027	100kΩ ±1% resistor (0603)	1	R137	Any	Any
0028	51.1kΩ ±1% resistors (0603)	2	R156, R157	Any	Any
0029	Dual Buck (28-pinTQFN 5x5x0.8mm)	1	U1	Maxim	MAX17233
	Not Installed Capacitors (0603)	0	C4, C5, C102, C103		
	Not Installed Capacitors (2220)	0	C117, C118		
	Not Installed Resistors (0603)	0	R119, R120, R131, R132		
0030	Shunts	6	See Jumper Table	Kycon	SX1100-B
0031	PC board: MAX17233 EV KIT	1	2 oz Cu	Network PCB	MAX17233

MAX17233 EVKIT	
	REV A
	
LAYER TOP SILKSCREEN	
DATE: JAN 2016	ALL UNITS ARE IN 0.001"

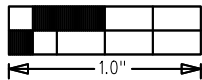
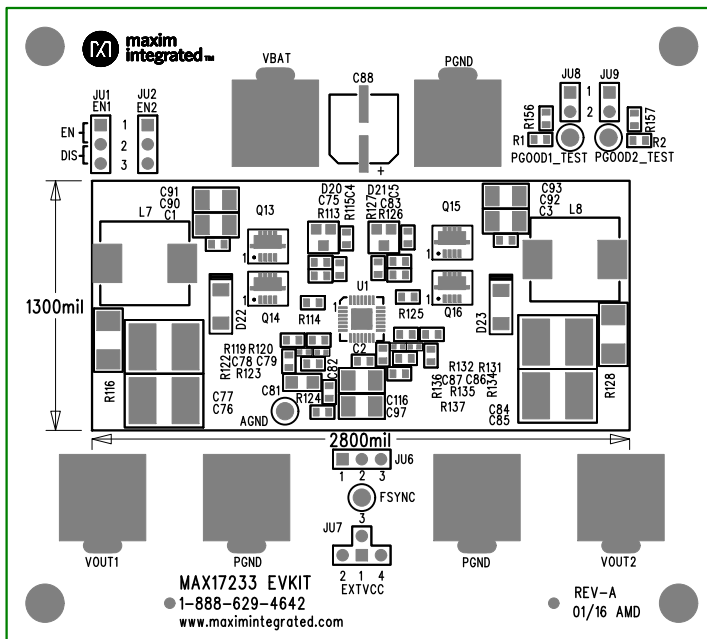

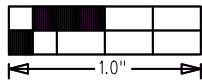
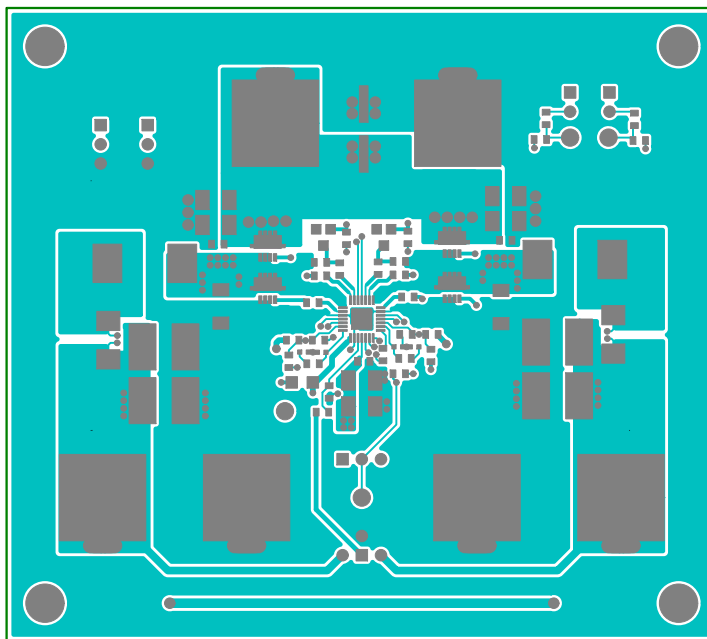

MAX17233 EVKIT	
	REV A
 <b>maxim integrated™</b>	
LAYER	COMPONENT SIDE
DATE: JAN 2016	ALL UNITS ARE IN 0.001"





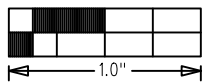
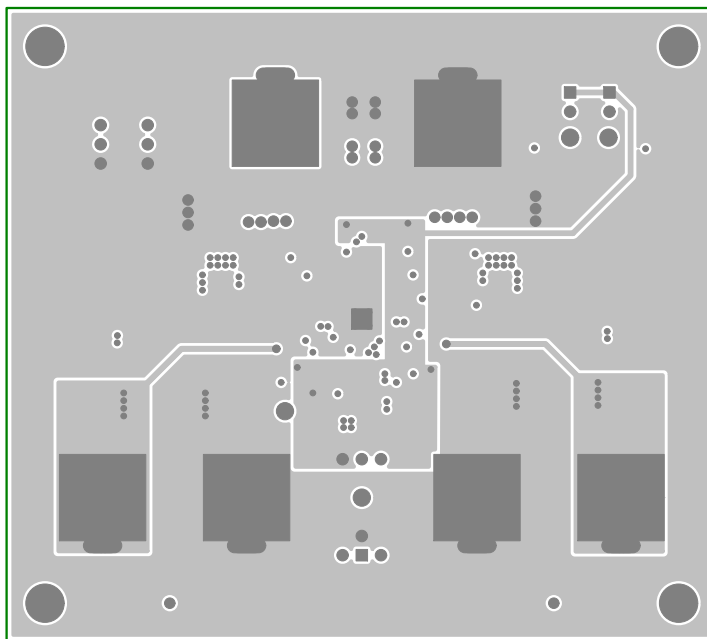

MAX17233 EVKIT	
	REV A
	
LAYER LAYER 2 GND	
DATE: JAN 2016	ALL UNITS ARE IN 0.001"

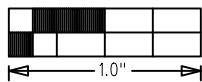
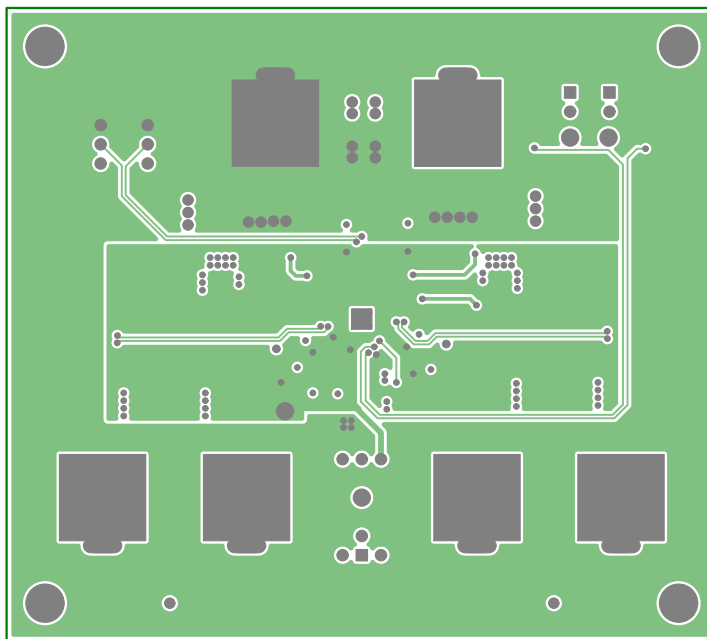

MAX17233 EVKIT	
	REV A
	
LAYER LAYER 3 PWR	
DATE: JAN 2016	ALL UNITS ARE IN 0.001"



MAX17233 EVKIT	
	REV A
 <b>maxim integrated™</b>	
LAYER SOLDER SIDE	
DATE: JAN 2016	ALL UNITS ARE IN 0.001"

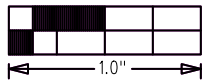
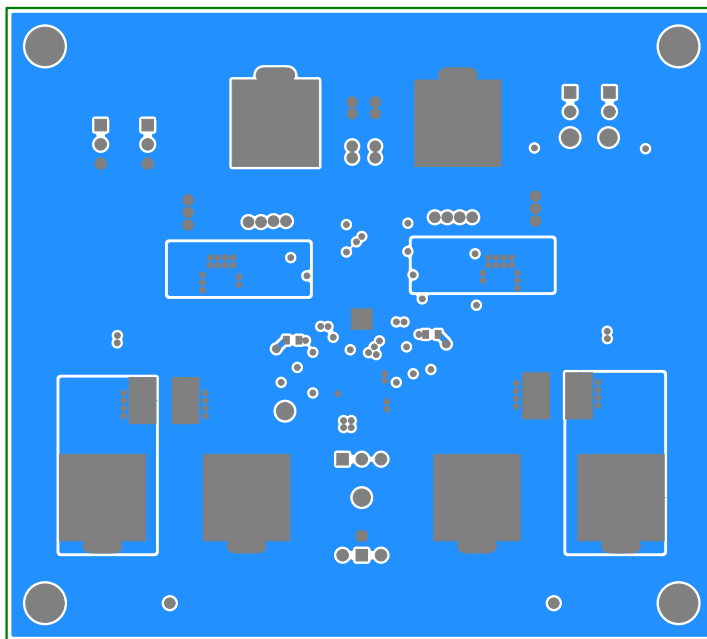

MAX17233 EVKIT	
	REV A
	
LAYER BOTTOM SILKSCREEN	
DATE: JAN 2016	ALL UNITS ARE IN 0.001"

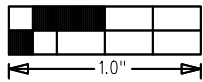
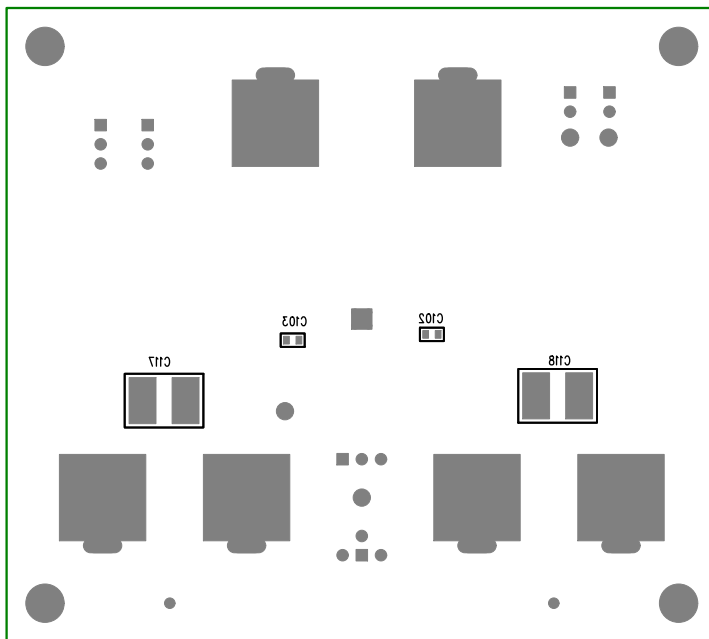

C

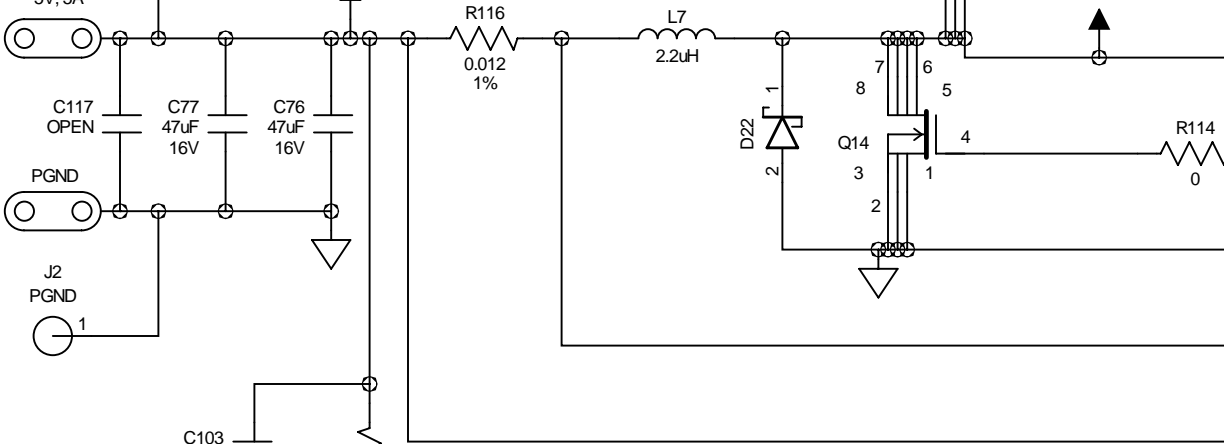

B

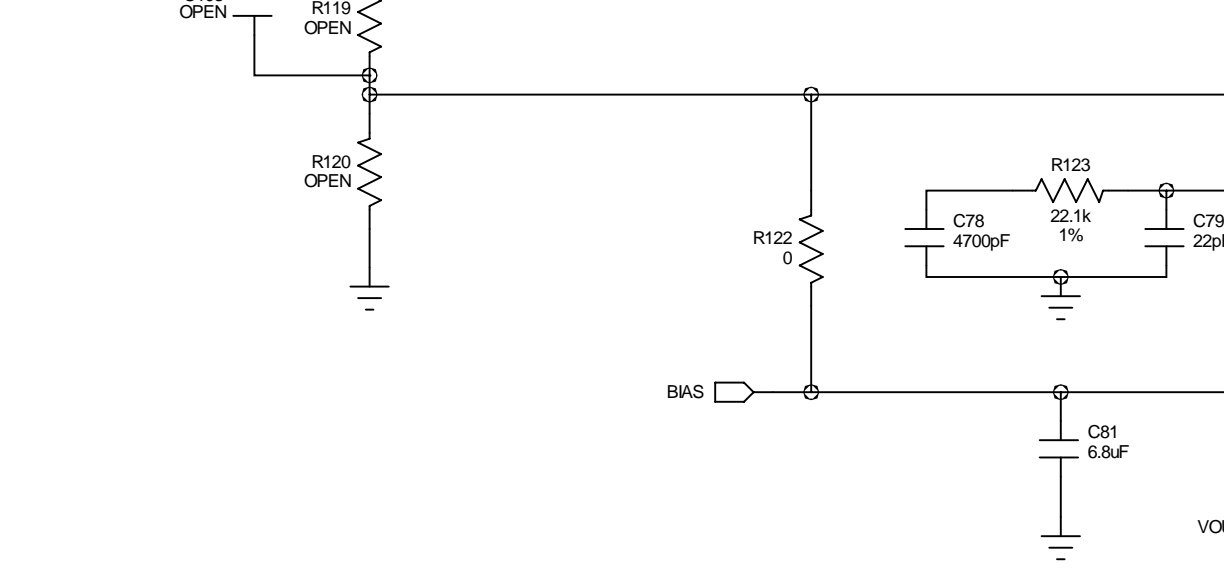

A



C

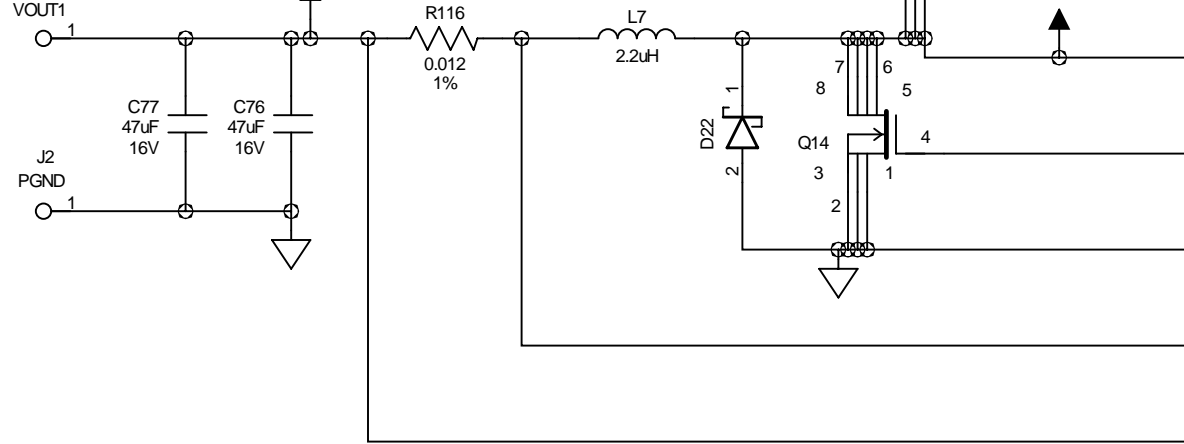

B

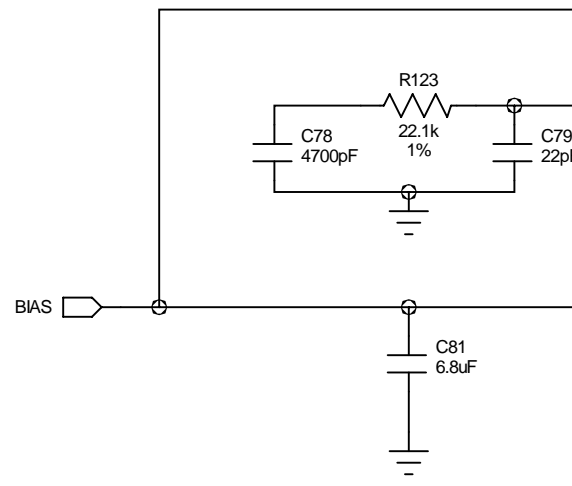

A

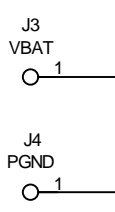

## X-ON Electronics

Largest Supplier of Electrical and Electronic Components

*Click to view similar products for [Power Management IC Development Tools](#) category:*

*Click to view products by [Maxim](#) manufacturer:*

Other Similar products are found below :

[EVB-EP5348UI](#) [MIC23451-AAAYFL EV](#) [MIC5281YMME EV](#) [124352-HMC860LP3E](#) [DA9063-EVAL](#) [ADP122-3.3-EVALZ](#) [ADP130-0.8-EVALZ](#) [ADP130-1.8-EVALZ](#) [ADP1740-1.5-EVALZ](#) [ADP1870-0.3-EVALZ](#) [ADP1874-0.3-EVALZ](#) [ADP199CB-EVALZ](#) [ADP2102-1.25-EVALZ](#) [ADP2102-1.875EVALZ](#) [ADP2102-1.8-EVALZ](#) [ADP2102-2-EVALZ](#) [ADP2102-3-EVALZ](#) [ADP2102-4-EVALZ](#) [AS3606-DB](#) [BQ25010EVM](#) [BQ3055EVM](#) [ISLUSBI2CKIT1Z](#) [LP38512TS-1.8EV](#) [EVAL-ADM1186-1MBZ](#) [EVAL-ADM1186-2MBZ](#) [ADP122UJZ-REDYKIT](#) [ADP166Z-REDYKIT](#) [ADP170-1.8-EVALZ](#) [ADP171-EVALZ](#) [ADP1853-EVALZ](#) [ADP1873-0.3-EVALZ](#) [ADP198CP-EVALZ](#) [ADP2102-1.0-EVALZ](#) [ADP2102-1-EVALZ](#) [ADP2107-1.8-EVALZ](#) [ADP5020CP-EVALZ](#) [CC-ACC-DBMX-51](#) [ATPL230A-EK](#) [MIC23250-S4YMT EV](#) [MIC26603YJL EV](#) [MIC33050-SYHL EV](#) [TPS60100EVM-131](#) [TPS65010EVM-230](#) [TPS71933-28EVM-213](#) [TPS72728YFFEVM-407](#) [TPS79318YEQEVM](#) [UCC28810EVM-002](#) [XILINXPWR-083](#) [LMR22007YMINI-EVM](#) [LP38501ATJ-EV](#)