

# MAX17242 Evaluation Kit with Preset 3.3V/2A Output

Evaluates: MAX17242

## General Description

The MAX17242 evaluation kit (EV kit) demonstrates the MAX17242 high-voltage, current-mode step-down converters with low operating current. The EV kit operates over a wide 3.5V to 36V input range and the output is set for 3.3V at 2A.

The EV kit comes with the MAX17242ETPB installed.

## Features

- Wide 3.5V to 36V Input Supply Range
- 96% Peak Efficiency at 3.5V Input in Skip Mode
- Forced-PWM or Skip-Mode Operation
- Programmable Switching Frequency (400kHz Default)
- Selectable Spread Spectrum Optimizes EMI Performance
- FSYNC Input and Power-Good Output
- Proven 4-Layer 2oz Copper PCB Layout
- Demonstrates 950mil x 835mil Solution Size
- Fully Assembled and Tested

## Quick Start

### Required Equipment

- MAX17242EV kit
- 12V, 2A DC power supply
- Electronic load capable of 2A
- Digital voltmeter (DVM)

### Procedure

The EV kit is fully assembled and tested. Follow the steps below to verify board operation. **Caution: Do not turn on supplies until all connections are made.**

- 1) Verify that jumpers JU1–JU4 are in their default positions, as shown in [Table 1](#) through [Table 4](#).
- 2) Connect the power supply between the VINSUPSW and nearest PGND 2-hole pads or test points.
- 3) Connect the 2A electronic load between the VOUT and nearest PGND 2-hole pads or test points.
- 4) Connect the DVM between the VOUT and nearest PGND test points.
- 5) Turn on the power supply.
- 6) Enable the electronic load.
- 7) Verify that the voltage at the VOUT test point is approximately 3.3V.

**Table 1. EN Configuration (JU1)**

SHUNT POSITION	EN PIN	MODE
1-2*	Connected to SUP	Normal Operation
2-3	Connected to PGND	Shutdown Mode

\*Default position.

**Table 2. Operating-Mode and Frequency Control (JU2)**

SHUNT POSITION	FSYNC PIN	MODE
1-2*	Connected to BIAS	Forced-PWM mode
2-3	Connected to AGND	Skip mode
Not installed	Connected to FSYNC test point and external clock	Forced-PWM mode (device syncs to an external clock)

\*Default position.

**Table 3. Spread Spectrum (JU3)**

SHUNT POSITION	SPS PIN	MODE
1-2*	Connected to BIAS	Spread-Spectrum Enabled
2-3	Connected to AGND	Spread-Spectrum Disabled

\*Default position.

**Table 4. PGOOD (JU4)**

SHUNT POSITION	MODE
Installed*	PGOOD pulled high to BIAS
Not installed	PGOOD pulled high to V_PULL

\*Default position.

[Ordering Information](#) appears at end of data sheet.

# MAX17242 Evaluation Kit with Preset 3.3V/2A Output

Evaluates: MAX17242

## Detailed Description of Hardware

The MAX17242EV kit demonstrates the MAX17242 high-voltage, high-frequency, step-down converter with low operating current. The EV kit operates over a wide 3.3V to 36V input range and the output is set for 3.3V at 2A. Consider thermal and switching efficiency when designing for operation in the 24V–36V input voltage range.

### Enable (EN)

Place a shunt in the 1-2 position on JU1 for normal operation. To place the device into shutdown mode, move the shunt on JU1 to the 2-3 position.

### Synchronization Input (FSYNC)

The EV kit features jumper JU2 to control the synchronization input (FSYNC). The device synchronizes to an external signal applied to FSYNC. Connect FSYNC to AGND to enable skip-mode operation. Connect to BIAS to enable Forced-PWM mode, or to an external clock to enable fixed-frequency forced-PWM mode operation.

To use an external clock, uninstall the shunt on jumper JU2 and apply the signal at the FSYNC test point and AGND. The external clock frequency at FSYNC can be higher or lower than the internal clock by 20%. Ensure that the duty cycle of the external clock used has a minimum 100ns pulse width. The external clock logic High voltage can be in the 1.4V–5V range.

### Spread-Spectrum Option (SPS)

The EV kit provides jumper JU3 that allows SPS to be pulled high (BIAS) or pulled low (AGND). Connect SPS high to enable spread spectrum where the operating frequency is varied  $\pm 3\%$  centered on FOSC. Connect SPS low to disable the spread-spectrum feature.

### Setting the Switching Frequency (FOSC)

The EV kit switches at 400kHz by default, and the switching frequency is set by a resistor,  $R_{FOSC}$  (R4), connected from FOSC to AGND. Refer to TOC08 in the *Typical Operating Characteristics* section of the MAX17242 IC data sheet for the correct  $R_{FOSC}$  (R4) value.

## Power-Good Output (PGOOD)

The EV kit provides a PGOOD test point to monitor the status of the device output. PGOOD asserts when  $V_{OUT}$  rises above 95% of its regulation voltage. PGOOD deasserts when  $V_{OUT}$  drops below 92.5% of its regulation voltage. R5 pulls PGOOD up to BIAS or  $V_{PULL}$  with respect to AGND. When operating in Skip-mode, use an external voltage source for  $V_{PULL}$ . Remove the shunt on jumper JU4 and connect an external voltage source up to 5.5V to the  $V_{PULL}$  2-hole pad.

## Output

Resistor R6 connects FB to BIAS for a fixed +3.3V (EV kit default output) or a fixed +5V output voltage. To set the output to other voltages between 1V and 10V, connect a resistive divider from output (OUT) to FB to AGND. Use the following equation to determine the R7 and R8 of the resistive divider network:

$$R7 = R8 \times \left( \frac{V_{OUT}}{V_{FB}} - 1 \right)$$

where  $V_{FB} = 1V$  and  $R8$  is  $\leq 500k\Omega$ .

## Operation at 1MHz Switching Frequency

For 1MHz switching frequency, the following components must be changed to:

- R4 = 27.4k $\Omega$
- L1 = 4.7 $\mu$ H (recommend Coilcraft XAL6060-472MEB)
- R1 = 12.1k $\Omega$
- C10 = 6,800pF

Additional capacitance on C8 may be needed, depending on transient performance.

# MAX17242 Evaluation Kit with Preset 3.3V/2A Output

Evaluates: MAX17242

## Component Suppliers

SUPPLIER	WEBSITE
Coilcraft Inc.	www.coilcraft.com
Murata Americas	www.murata.com
Panasonic Corp.	www.panasonic.com
TDK Corporation	www.tdk.com

**Note:** Indicate that you are using the MAX17242 when contacting these component suppliers.

## MAX17242 EV Bill of Materials

Ref_Des	Description	Per	Part Number
C1	150uF, 50V aluminum electrolytic capacitor (G, 10x10.2)	1	Panasonic EEE-FK1H151P
C2	4.7uF 10%, 50V X7R ceramic capacitor (1210)	1	Murata GCM32ER71H475KA55L
C3, C5	0.1uF 10%, 50V X7R ceramic capacitor (0603)	2	Murata GCM188R71H104KA57D
C4	2.2uF 10%, 50V X7R ceramic capacitor (0805)	1	TDK C2012X7R1H225K125AC
C6	0.1uF 10%, 50V X7R ceramic capacitor (0402)	1	TDK CGA2B3X7R1H104K050BB
C7	22uF 10%, 10V X7R ceramic capacitors (1210)	1	Murata GCM32ER71A226KE12L
C9	2.2uF 10%, 10V X7R ceramic capacitor (0603)	1	Murata GRM188R71A225K
C10	2200pF 10% 50V X7R ceramic capacitor (0402)	1	Murata GRM155R71H222K
C11	3pF 0.25% 50V C0G ceramic capacitor (0402)	1	Murata GRM1555C1H3R0C
SUP, VINSUPSW, VOUT	Multipurpose test points, red	3	Keystone 5010
PGND, PGND, AGND	Multipurpose test points, black	3	Keystone 5011
PGOOD	Multipurpose test point, yellow	1	Keystone 5014
JU1-JU3	3 pin header, 2.54MM, Comes in 36-40 Pin Strips (CUT TO FIT)	3	SULLINS PEC36SAAN
JU4	2 pin header, 2.54MM, Comes in 36-40 Pin Strips (CUT TO FIT)	1	SULLINS PEC36SAAN
L1	10uH, 7.6A Shielded Power inductor	1	Coilcraft XAL6060-103MEB
R1	15.8k ohms 1% resistor (0402)	1	Any
R2, R6, R11	0 ohms 5% resistor (0402)	3	Any
R3	100k ohms 5% resistor (0402)	1	Any
R4	73.2k ohms 1% resistor (0402)	1	Any
R5	10k ohms 5% resistor (0402)	1	Any
R9	0 ohms 5% resistor (1210)	1	Any
U1	220kHz to 2.2MHz, 2A Fully Integrated Step-down Converter (20 TQFN-EP)	1	Maxim max17242ETPB+
	Shunts	4	Kycon SX1100-B
2 oz.	PC board: max17242 EVALUATION KIT	1	
C8	Not installed, ceramic capacitor (1210)	0	
C13	Not installed, ceramic capacitor (0603)	0	
C12, C14, C15, C16, C17	Not installed, ceramic capacitor (0402)	0	
C18	Not installed, ceramic capacitor (0805)	0	
L2	Not Installed, Ferrite Bead (1206)	0	
FSYNC	Not Installed Multipurpose test point, yellow	0	Keystone 5014
R7, R8, R10	Not installed, resistor (0402)	0	

# MAX17242 Evaluation Kit with Preset 3.3V/2A Output

Evaluates: MAX17242

## MAX17242 EV Schematics

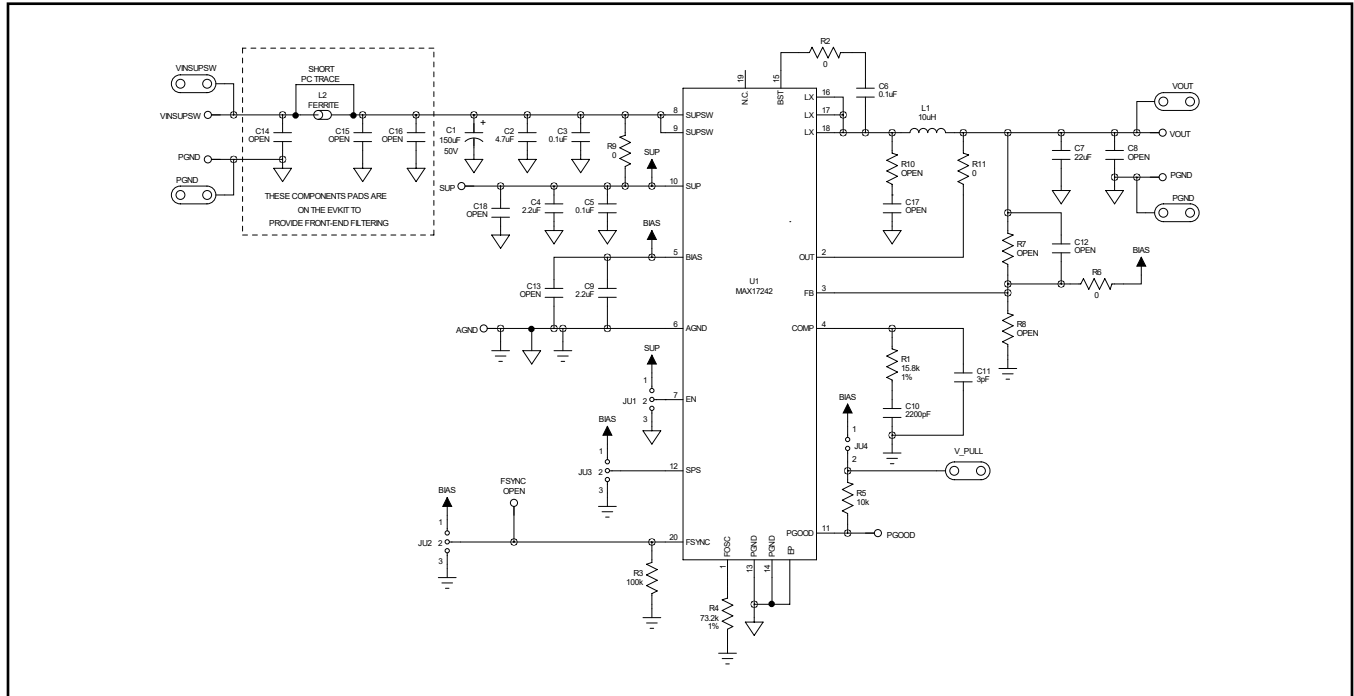

MAX17242 EV Schematic

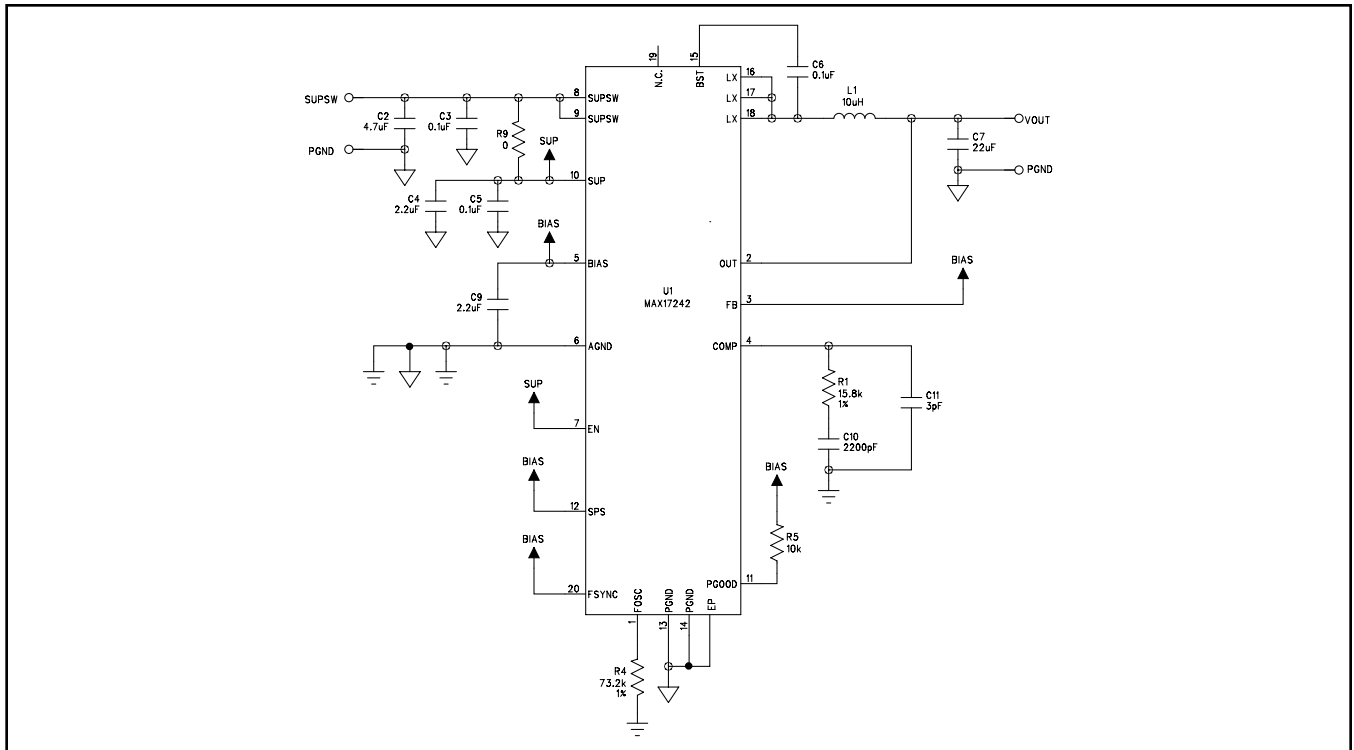

MAX17242 EV Minimal Component Schematic

# MAX17242 Evaluation Kit with Preset 3.3V/2A Output

Evaluates: MAX17242

## MAX17242 EV PCB Layout

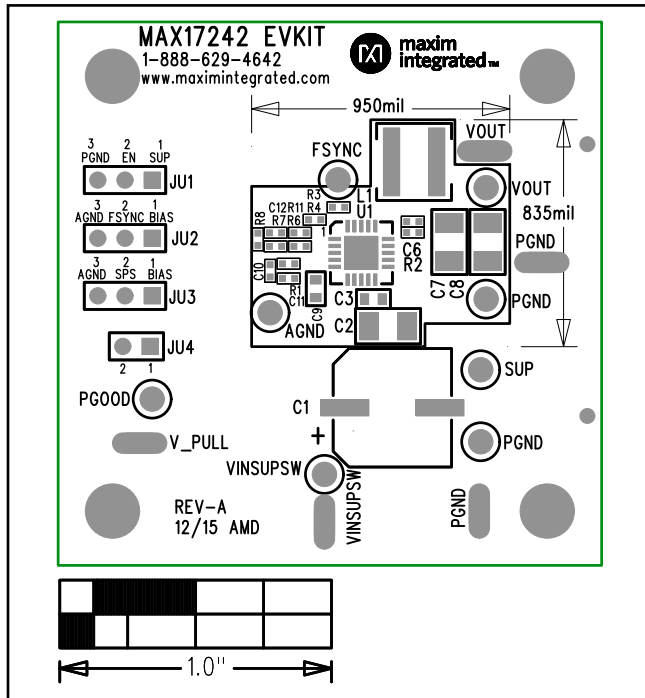

MAX17242 EV Top Silkscreen

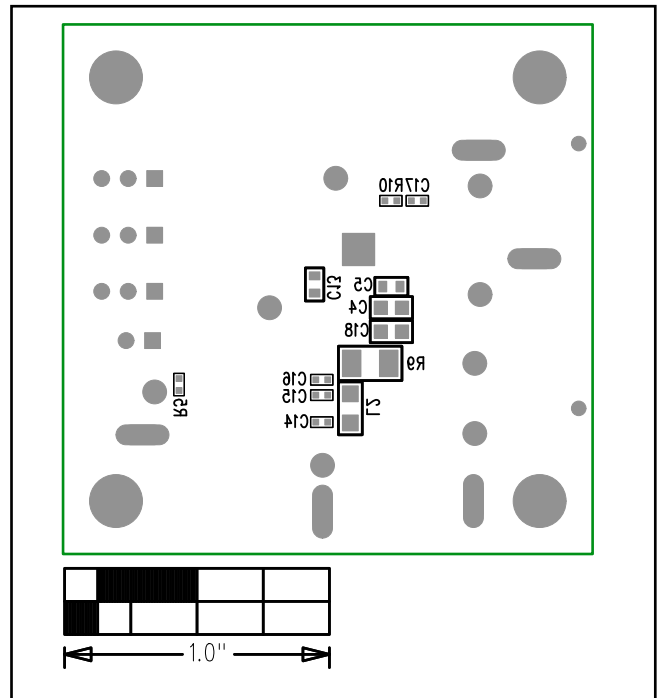

MAX17242 EV Bottom Silkscreen

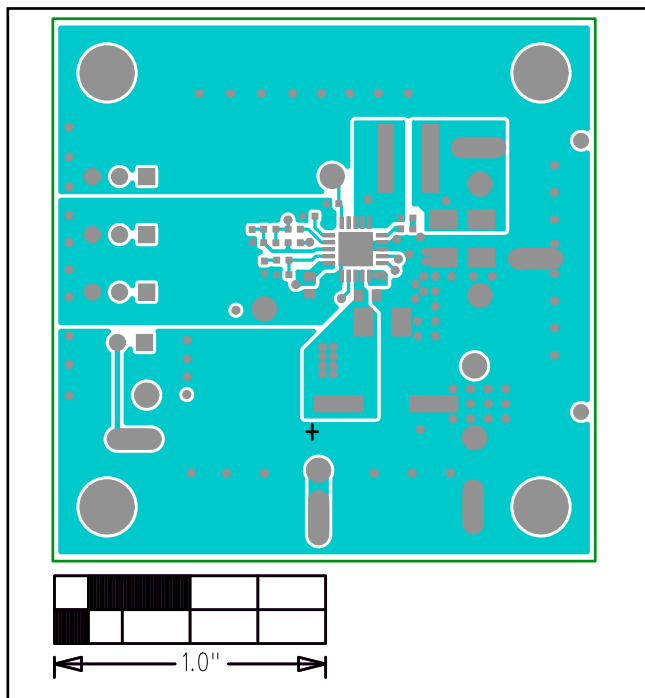

MAX17242 EV Component Side

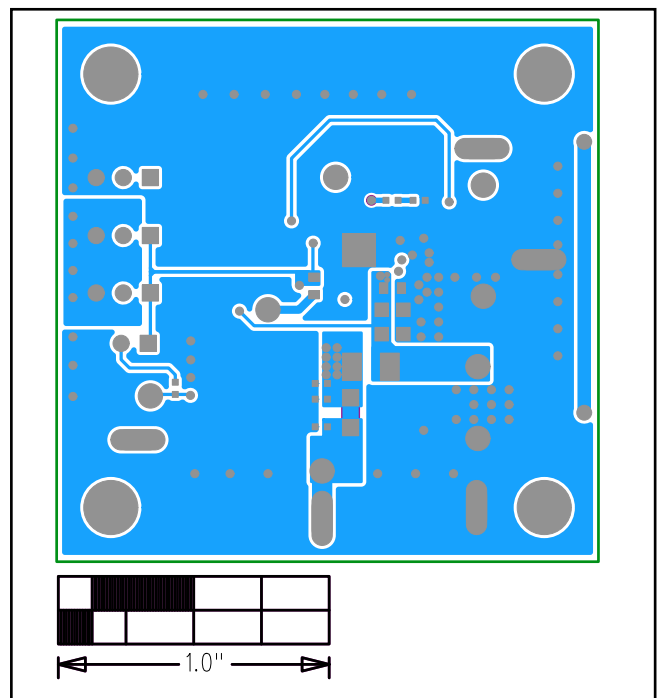

MAX17242 EV Solder Side

MAX17242 EV PCB Layout (Continued)

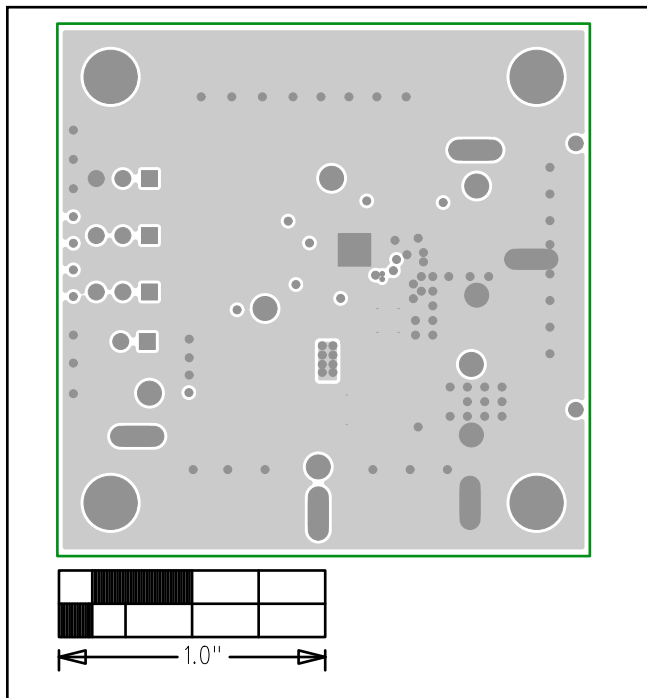

MAX17242 EV Layer 2-PGND

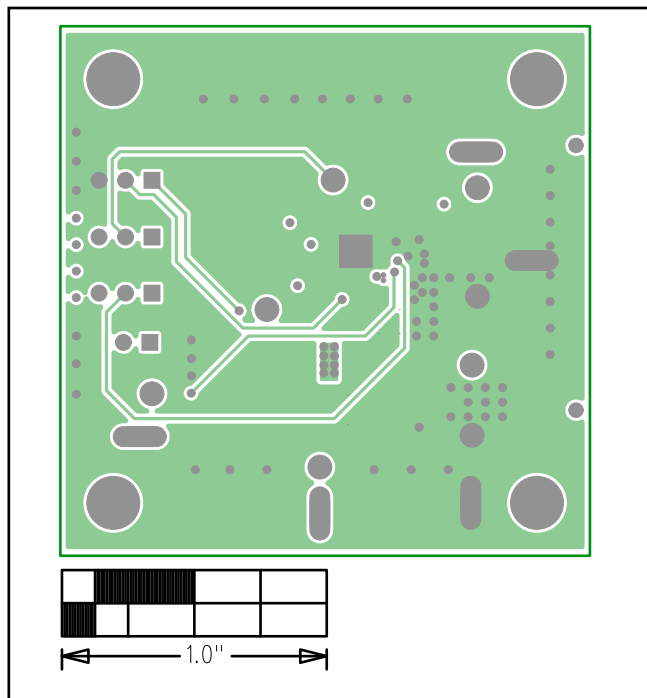

MAX17242 EV Layer 3-Signal PGND

Ordering Information

PART	TYPE
MAX17242EVKIT#	EV Kit

#Denotes RoHS compliant.

MAX17242 Evaluation Kit with Preset  
3.3V/2A Output

Evaluates: MAX17242

## Revision History

REVISION NUMBER	REVISION DATE	DESCRIPTION	PAGES CHANGED
0	12/15	Initial release	—
1	5/16	Updated Table 2	1
2	8/16	Removed FSYNC information in Table 2	1
3	5/18	Updated bill of materials, schematic, and PCB layout diagrams	3–6

For pricing, delivery, and ordering information, please contact Maxim Direct at 1-888-629-4642, or visit Maxim Integrated's website at [www.maximintegrated.com](http://www.maximintegrated.com).

*Maxim Integrated cannot assume responsibility for use of any circuitry other than circuitry entirely embodied in a Maxim Integrated product. No circuit patent licenses are implied. Maxim Integrated reserves the right to change the circuitry and specifications without notice at any time.*

## X-ON Electronics

Largest Supplier of Electrical and Electronic Components

*Click to view similar products for [Power Management IC Development Tools](#) category:*

*Click to view products by [Maxim](#) manufacturer:*

Other Similar products are found below :

[EVB-EP5348UI](#) [MIC23451-AAAYFL EV](#) [MIC5281YMME EV](#) [124352-HMC860LP3E](#) [DA9063-EVAL](#) [ADP122-3.3-EVALZ](#) [ADP130-0.8-EVALZ](#) [ADP130-1.8-EVALZ](#) [ADP1740-1.5-EVALZ](#) [ADP1870-0.3-EVALZ](#) [ADP1874-0.3-EVALZ](#) [ADP199CB-EVALZ](#) [ADP2102-1.25-EVALZ](#) [ADP2102-1.875EVALZ](#) [ADP2102-1.8-EVALZ](#) [ADP2102-2-EVALZ](#) [ADP2102-3-EVALZ](#) [ADP2102-4-EVALZ](#) [AS3606-DB](#) [BQ25010EVM](#) [BQ3055EVM](#) [ISLUSBI2CKIT1Z](#) [LP38512TS-1.8EV](#) [EVAL-ADM1186-1MBZ](#) [EVAL-ADM1186-2MBZ](#) [ADP122UJZ-REDYKIT](#) [ADP166Z-REDYKIT](#) [ADP170-1.8-EVALZ](#) [ADP171-EVALZ](#) [ADP1853-EVALZ](#) [ADP1873-0.3-EVALZ](#) [ADP198CP-EVALZ](#) [ADP2102-1.0-EVALZ](#) [ADP2102-1-EVALZ](#) [ADP2107-1.8-EVALZ](#) [ADP5020CP-EVALZ](#) [CC-ACC-DBMX-51](#) [ATPL230A-EK](#) [MIC23250-S4YMT EV](#) [MIC26603YJL EV](#) [MIC33050-SYHL EV](#) [TPS60100EVM-131](#) [TPS65010EVM-230](#) [TPS71933-28EVM-213](#) [TPS72728YFFEVM-407](#) [TPS79318YEQEVM](#) [UCC28810EVM-002](#) [XILINXPWR-083](#) [LMR22007YMINI-EVM](#) [LP38501ATJ-EV](#)