

General Description

The MAX17270 evaluation kit (EV kit) evaluates the MAX17270. The MAX17270 is a 3-output switching regulator that regulates three outputs using a single, small 2.2 μ H inductor.

The MAX17270 EV kit features two independent circuits to evaluate two different IC packages of the MAX17270. Both circuits on the EV kit operate over an input range of 2.7V to 5.5V. Each circuit provides three jumper-configurable outputs, with voltages from 0.8V to 5V for each output channel. Each circuit output on the EV kit delivers up to 50mA/75mA/80mA of current depending on the input voltage to the output voltage ratio.

The EV kit comes with the MAX17270ETE+ and the MAX17270ENE+ installed.

Features

- Two Independent Circuits on One Board
 - Evaluates the MAX17270 IC in a 16-pin TQFN
 - Evaluates the MAX17270 IC in a 4 x 4 Bump, 0.4mm Pitch WLP
- 2.7V to 5.5V Input Range
- 0.8V to 5V Configurable Output Voltage
- Up to 50mA/75mA/80mA Output Current
- Proven 4-Layer 1oz Copper PCB Layout
- Demonstrates Compact Solution Size
- Fully Assemble and Tested

Ordering Information appears at end of data sheet.

MAX17270 EV Kit Files

FILE	DESCRIPTION
MAX17270 EV BOM	EV Kit Bill of Materials
MAX17270 EV PCB Layout	EV Kit Layout
MAX17270 EV Schematic	EV Kit Schematic

Quick Start

Required Equipment

- MAX17270 EV kit
- 2.7V to 5.5V, 1A DC power supply
- Electronic load capable of 100mA
- Digital voltmeter (DVM)

Procedure

<<Testing the TQFN Circuit>>

The EV kit is fully assembled and tested. Follow the steps below to verify board operation.

Caution: Do not turn on power supply until all connections are completed.

- 1) Verify that jumpers JU1 to JU6 are in their default positions, as shown in [Table 1](#) through [Table 4](#).
- 2) Connect the 2.7V to 5.5V power supply between the IN1 and nearest PGND1 terminal posts.
- 3) Turn on the power supply and set the power supply output to 3V.
- 4) Verify that the output voltage at OUT1 and nearest PGND1 terminal posts is 1.0V.
- 5) Verify that the output voltage at OUT2 and nearest PGND1 terminal posts is 1.8V.
- 6) Verify that the output voltage at OUT3 and nearest PGND1 terminal posts is 3.3V.
- 7) Connect the electronic load between OUT1 and PGND1. Set the electronic load to 50mA
- 8) Enable the electronic load and verify that OUT1 is still 1.0V
- 9) Connect the electronic load between OUT2 and PGND1. Set the electronic load to 75mA
- 10) Enable the electronic load and verify that OUT2 is still 1.8V
- 11) Connect the electronic load between OUT3 and PGND1. Set the electronic load to 80mA
- 12) Enable the electronic load and verify that OUT3 is still 3.3V

Procedure

<<Testing the WLP Circuit>>

The EV kit is fully assembled and tested. Follow the steps below to verify board operation.

Caution: Do not turn on power supply until all connections are completed.

- 13) Verify that jumpers JU101 to JU106 are in their default positions, as shown in [Table 5](#) through [Table 8](#).
- 14) Connect the 2.7V to 5.5V power supply between the IN and nearest PGND terminal posts.
- 15) Turn on the power supply and set the power supply output to 3V.
- 16) Verify that the output voltage at OUT101 and nearest PGND terminal posts is 1.0V.
- 17) Verify that the output voltage at OUT102 and nearest PGND terminal posts is 1.8V.
- 18) Verify that the output voltage at OUT103 and nearest PGND terminal posts is 3.3V.
- 19) Connect the electronic load between OUT101 and PGND. Set the electronic load to 50mA.
- 20) Enable the electronic load and verify that OUT101 is still 1.0V.

- 21) Connect the electronic load between OUT102 and PGND. Set the electronic load to 75mA.
- 22) Enable the electronic load and verify that OUT102 is still 1.8V.
- 23) Connect the electronic load between OUT103 and PGND. Set the electronic load to 80mA.
- 24) Enable the electronic load and verify that OUT103 is still 3.3V.

Detailed Description of Hardware

The MAX17270 EV kit evaluates the MAX17270. The MAX17270 is a 3-output switching regulator that regulates three outputs using a single, small 2.2µH inductor.

The MAX17270 EV kit features two independent circuits to evaluate two different IC packages of the MAX17270, the 16-pin TQFN and the 4x4 bump, 0.4mm pitch, WLP. Both circuits on the EV kit operates over an input voltage range of 2.7V to 5.5V. Each circuit provides three output channels. Each output channel provides an output with a jumper-configurable voltage from 0.8V to 5V. Each circuit output channel delivers up to 50mA/75mA/80mA of current depending on the input voltage to the output voltage ratio.

The EV kit comes with the MAX17270ETE+ and the MAX17270ENE+ installed.

Table 1. EN1–EN3 (JU1 – JU3) on MAX17270 (TQFN) Circuit

JU1 - JU3 SHUNT POSITION	DESCRIPTION
1–2*	Enabled. EN_ = IN1
2–3	Disabled. EN_ = PGND1
OPEN	Enabled. EN_ = high (through internal pullup)

*Default position.

Table 2. RSEL1 (JU4) on MAX17270 (TQFN) Circuit

JU4 SHUNT POSITION	RSEL1 CONNECTED TO	OUT1	OUT1 CURRENT LIMIT
1–2	R4 = 1M	0.8V	0.5A
1–3*	R5 = 768k	1.0V	0.5A
1–4	R6 = 536k	1.2V	0.5A

*Default position.

Table 3. RSEL2 (JU5) on MAX17270 (TQFN) Circuit

JU5 SHUNT POSITION	RSEL2 CONNECTED TO	OUT2	OUT2 CURRENT LIMIT
1–2	R7 = 20k	1.5V	1A
1–3*	R8 = 16.9k	1.8V	1A
1–4	R9 = 14k	2.2V	1A

*Default position.

Table 4. RSEL3 (JU6) on MAX17270 (TQFN) Circuit

JU6 SHUNT POSITION	RSEL3 CONNECTED TO	OUT3	OUT3 CURRENT LIMIT
1–2	R10 = 11.8k	2.5V	1A
1–3*	R11 = 8.45k	3.3V	1A
1–4	R12 = 0	5V	1A

*Default position.

Table 5. EN101–EN103 (JU101–JU103) on MAX17270 (WLP) Circuit

JU101–JU103 SHUNT POSITION	DESCRIPTION
1–2*	Enabled. EN_ = IN
2–3	Disabled. EN_ = PGND
OPEN	Enabled. EN_ = high (via internal pull up)

*Default position.

Table 6. RSEL101 (JU104) on MAX17270 (WLP) Circuit

JU104 SHUNT POSITION	RSEL101 CONNECTED TO	OUT101	OUT101 CURRENT LIMIT
1–2	R104 = 1M	0.8V	0.5A
1–3*	R105 = 768k	1.0V	0.5A
1–4	R106 = 536k	1.2V	0.5A

*Default position.

Table 7. RSEL102 (JU105) on MAX17270 (WLP) Circuit

JU105 SHUNT POSITION	RSEL102 CONNECTED TO	OUT102	OUT102 CURRENT LIMIT
1–2	R107 = 20k	1.5V	1A
1–3*	R108 = 16.9k	1.8V	1A
1–4	R109 = 14k	2.2V	1A

*Default position.

Table 8. RSEL103 (JU106) on MAX17270 (WLP) Circuit

JU106 SHUNT POSITION	RSEL1032 CONNECTED TO	OUT103	OUT103 CURRENT LIMIT
1–2	R110 = 11.8k	2.5V	1A
1–3*	R111 = 8.45k	3.3V	1A
1–4	R112 = 0	5V	1A

*Default position.

Enable Function for the MAX17270ETE+ (TQFN) Circuit

The MAX17270 (TQFN) circuit on the EV kit provides three jumpers JU1, JU2, and JU3 to individually enable or disable each output channel. Refer to [Table 1](#) for jumper setting of jumpers JU1, JU2, and JU3.

Output Voltage Selection for the MAX17270ETE+ (TQFN) Circuit

The MAX17270 (TQFN) circuit on the EV kit provides three jumpers JU4, JU5, and JU6 (RSEL1, RSEL2 and RSEL3) to configure the output voltage for each output channel. Refer to [Table 2](#), [Table 3](#), and [Table 4](#) for jumper setting of jumpers JU4, JU5, and JU6.

Enable Function for the MAX17270ENE+ (WLP) Circuit

The MAX17270 (WLP) circuit on the EV kit provides three jumpers JU101, JU102, and JU103 to individually enable or disable each output channel. Refer to [Table 5](#) for jumper setting of jumpers JU101–JU103.

Ordering Information

PART	TYPE
MAX17270EVKIT#	EV Kit

#Denotes RoHS compliant.

Output Voltage Selection for the MAX17270ENE+ (WLP) Circuit

The MAX17270 (WLP) circuit on the EV kit provides three jumpers JU104, JU105, and JU106 (RSEL101, RSEL102, and RSEL103) to configure the output voltage for each output channel. Refer to [Table 6](#), [Table 7](#), and [Table 8](#) for jumper setting of jumpers JU104, JU105, and JU106.

Spare Inductors

The MAX17270 EV kit provides spare inductors on the PCB’s bottom side. The spare inductors can be used to reconfigure the EV kit output current ratings.

Component Suppliers

SUPPLIER	WEBSITE
Coilcraft	www.coilcraft.com
Murata/TOKO	www.murata.com
TDK	www.tdk.com
Wurth Elektronik	www.we-online.com

Note: Indicate that you are using the MAX17270 when contacting these component suppliers.

MAX17270 EV Kit Bill of Materials

ITEM	REF_DES	DNI/DNP	QTY	MFG PART #	MANUFACTURER	VALUE	DESCRIPTION
1	C1, C101	—	2	CGA2B3X7R1H104K; C1005X7R1H104K050BB; GRM155R71H104KE14	TDK,TDK,MURATA	0.1µF	CAPACITOR: SMT (0402); CERAMIC CHIP; 0.1µF; 50V; TOL = 10%; TG = -55°C TO +125°C; TC = X7R
2	C3, C103	—	2	GRM188R71A105K; C0603X7R100-105; C1608X7R1A105K080AC; LMK107B7105KA; CL10B105KP8NFN	MURATA,VENKEL LTD,TDK; TAIYO YUDEN; SAMSUNG ELECTRONICS	1µF	CAPACITOR: SMT (0603); CERAMIC CHIP; 1µF; 10V; TOL = 10%; TG = -55°C TO +125°C; TC = X7R;
3	C4, C104	—	2	C1608XSR1A109K	TDK	10µF	CAPACITOR: SMT (0603); CERAMIC CHIP; 10µF; 10V; TOL = 10%; MODEL+; TG = -55°C TO +85°C; TC = X5R
4	C5-C7, C105-C107	—	6	C1608XSR1A226M080AC; GRM188R61A226ME15	TDK,MURATA	22µF	CAPACITOR: SMT (0603); CERAMIC CHIP; 22µF; 10V; TOL = 20%; TG = -55°C TO +85°C; TC = X5R
5	EN1-EN3, EN101-EN103	—	6	PEC03SAAN	SULLINS	PEC03SAAN	CONNECTOR, MALE, THROUGH HOLE; BREAKAWAY, STRAIGHT, 3PINS
6	IN, IN1, OUT1-OUT3, PGND1, PGND1, OUT101-OUT103, PGND1_OUT1-PGND1_OUT3, PGND_OUT101-PGND_OUT103	—	16	1514-2	KEYSTONE	1514-2	TERMINAL; TURRET; PIN DIA = 0.090IN; TOTAL LENGTH = 0.105IN; BOARD HOLE = 0.098IN; BRASS; TIN PLATING;
7	LXA, LXB, LXA1, LXB1, IN1_JACK, OUT1_JACK, OUT3_JACK, IN101_JACK, OUT101_JACK, OUT103_JACK	—	12	131-4353-00	TEKTRONICS	131-4353-00	CONNECTOR, WIREMOUNT; CIRCUIT BOARD TEST POINT MINIATURE PROBE, STRAIGHT, 4PINS
8	L1, L101	—	2	XFL4020-222ME	COILCRAFT	2.2µH	INDUCTOR; SMT; METAL COMPOSITE CORE; 2.2µH; TOL = ±20%; 8A; -40°C TO +125°C
9	L1A	—	1	MLP1005M1R0D70T0S1	TDK	1µH	INDUCTOR; SMT (0402); FERRITE CHIP; 1µH; TOL = ±20%; 0.5A
10	L1B	—	1	DFE160808S-1ROM=P2	MURATA	1µH	INDUCTOR; SMT (0603); MAGNETICALLY SHIELDED; 1µH; TOL = ±20%; 1.9A
11	L1C	—	1	DFM18PAN2R2MG0L	MURATA	2.2µH	INDUCTOR; SMT (0603); CERAMIC CHIP; 2.2µH; TOL = ±20%; 1.1A;
12	L1D	—	1	DFE201612E-1ROM	MURATA	1µH	INDUCTOR; SMT (0805); WIREWOUND CHIP; 1µH; TOL = ±20%; 2.9A
13	L1E	—	1	74479299222	WURTH ELECTRONICS INC	2.2µH	INDUCTOR; SMT (1210); MOLDED CHIP; 2.2µH; TOL = ±20%; 2.1A
14	L1F	—	1	74438357022	WURTH ELECTRONICS INC	2.2µH	EVKIT PART-INDUCTOR; SMT; SHIELDED; 2.2µH; TOL = ±20%; 5.2A;
15	L1G	—	1	DFE201612E-2R2M	MURATA	2.2µH	INDUCTOR; SMT (0805); WIREWOUND CHIP; 2.2µH; TOL = ±20%; 1.8A
16	R4, R104	—	2	CRCW06031M00FK; MCR03E2PFX1004	VISHAY DALE;ROHM	1M	RESISTOR, 0603, 1M OHM, 1%, 100PPM, 0.10W, THICK FILM
17	R5, R105	—	2	CRCW0603768KFK	VISHAY DALE	768K	RESISTOR, 0603, 768K OHM, 1%, 100PPM, 0.1W, THICK FILM
18	R6, R106	—	2	ERJ-3EKF5363	PANASONIC	536K	RESISTOR, 0603, 536K OHM, 1%, 100PPM, 0.1W, THICK FILM
19	R7, R107	—	2	MCR03E2PFX2002; ERJ-3EKF2002; CR0603-FX-2002ELF	ROHM,PANASONIC,BOURNS	20K	RESISTOR, 0603, 20K OHM, 1%, 100PPM, 0.10W, THICK FILM
20	R8, R108	—	2	ERJ-3EKF1692V; RC0603FR-0716K9	PANASONIC,YAGEO PHYCOMP	16.9K	RESISTOR, 0603, 16.9K OHM, 1%, 100PPM, 0.10W, THICK FILM
21	R9, R109	—	2	RC1-0603-1402F	INTERNATIONAL MANUFACTURING SERVICE	14K	RESISTOR, 0603, 14K OHM, 1%, 100PPM, 0.1W
22	R10, R110	—	2	ERJ-3EKF1182	PANASONIC	11.8K	RESISTOR, 0603, 11.8K OHM, 1%, 100PPM, 0.1W, THICK FILM
23	R11, R111	—	2	RC0603FR-078K45L	YAGEO PHYCOMP	8.45K	RESISTOR, 0603, 8.45K OHM, 1%, 100PPM, 0.10W, THICK FILM
24	R12, R13, R112, R113	—	4	CRCW06030000ZS; MCR03E2PJ000,ERJ-3GEY0R00	VISHAY DALE,ROHM,PANASONIC	0	RESISTOR, 0603, 0Ω, 0%; JUMPER, 0.10W, THICK FILM
25	RSEL1-RSEL3, RSEL101-RSEL103	—	6	22-28-4043	MOLEX	22-28-4043	CONNECTOR, MALE, THROUGH HOLE; FLAT VERTICAL BREAKAWAY, STRAIGHT, 4PINS
26	SU1-SU6, SU101-SU106	—	12	S1100-B,SX1100-B	KYCON,KYCON	SX1100-B	TEST POINT; JUMPER; STR; TOTAL LENGTH = 0.24IN; BLACK; INSULATION = PBT; PHOSPHOR BRONZE CONTACT = GOLD PLATED
27	TP_GND1_U1, TP_GND_U101	—	2	5001	KEYSTONE	N/A	TEST POINT; PIN DIA = 0.1IN; TOTAL LENGTH = 0.3IN; BOARD HOLE = 0.04IN; BLACK; PHOSPHOR BRONZE WIRE SILVER PLATE FINISH;
28	U1	—	1	MAX17270ETE-	MAXIM	MAX17270ETE-	EVKIT PART-IC; NANOPOWER TRIPLE/DUAL-OUTPUT SINGLE INDUCTOR MULTIPLE-OUTPUT (SIMO) BUCK BOOST REGULATOR; TQFN16-EP; PKG. CODE: T1633-5; PKG. OUTLINE DWG. NO.: 21-100136; PKG. LAND PATTERN NUMBER: 90-0032
29	U101	—	1	MAX17270ENE-	MAXIM	MAX17270ENE-	EVKIT PART-IC; ULTRA-LOW POWER TRIPLE-OUTPUT SINGLE INDUCTOR MULTIPLE OUTPUT (SIMO) BUCK BOOST REGULATOR; WLP16; 0.40MM PITCH; PACKAGE CODE: N161A1-1; PACKAGE OUTLINE DRAWING: 21-100150
30	VSUP, VSUP1	—	2	5002	KEYSTONE	N/A	TEST POINT; PIN DIA = 0.1IN; TOTAL LENGTH = 0.3IN; BOARD HOLE = 0.04IN; WHITE; PHOSPHOR BRONZE WIRE SILVER;
31	PCB	—	1	MAX17270	MAXIM	PCB	PCB MAX17270
32	JU7, JU107	DNP	0	PEC02SAAN	SULLINS	PEC02SAAN	CONNECTOR, MALE, THROUGH HOLE; BREAKAWAY; STRAIGHT; 2PINS
33	L2, L102	DNP	0	XFL4020-222ME	COILCRAFT	2.2µH	INDUCTOR; SMT; METAL COMPOSITE CORE; 2.2µH; TOL = ±20%; 8A; -40°C TO +125°C
34	TP_IN, TP_IN1, TP_OUT1-TP_OUT3, TP_PGND, TP_PGND1, TP_OUT101-TP_OUT103, TP_PGND1_OUT1-TP_PGND1_OUT3, TP_PGND_OUT101-TP_PGND_OUT103	DNP	0	5000	KEYSTONE	N/A	TEST POINT; PIN DIA = 0.1IN; TOTAL LENGTH=0.3IN; BOARD HOLE=0.04IN; RED; PHOSPHOR BRONZE WIRE SILVER PLATE FINISH;
TOTAL			100				

MAX17270 EV Kit Schematic

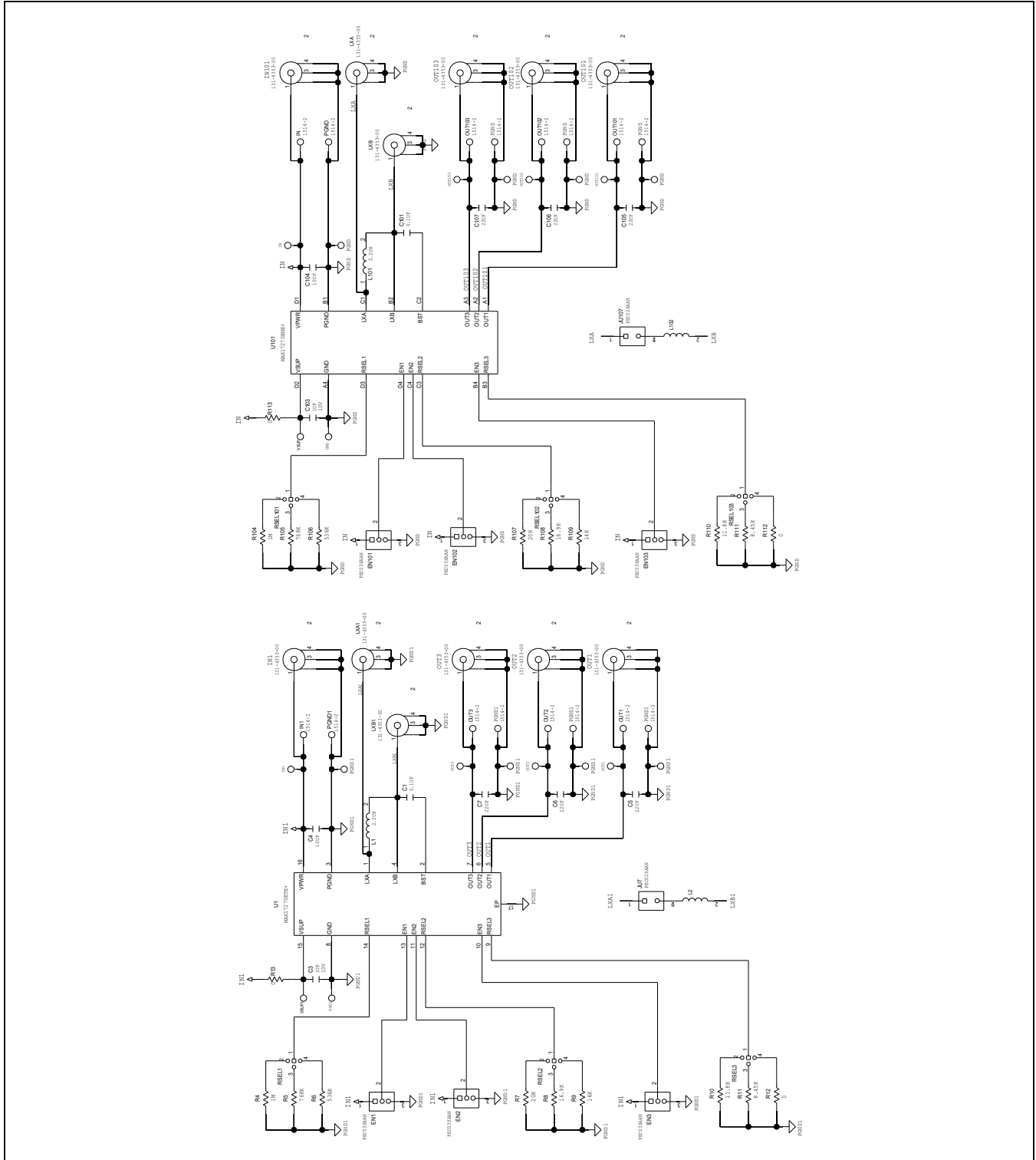

MAX17270 EV Kit PCB Layout Diagrams

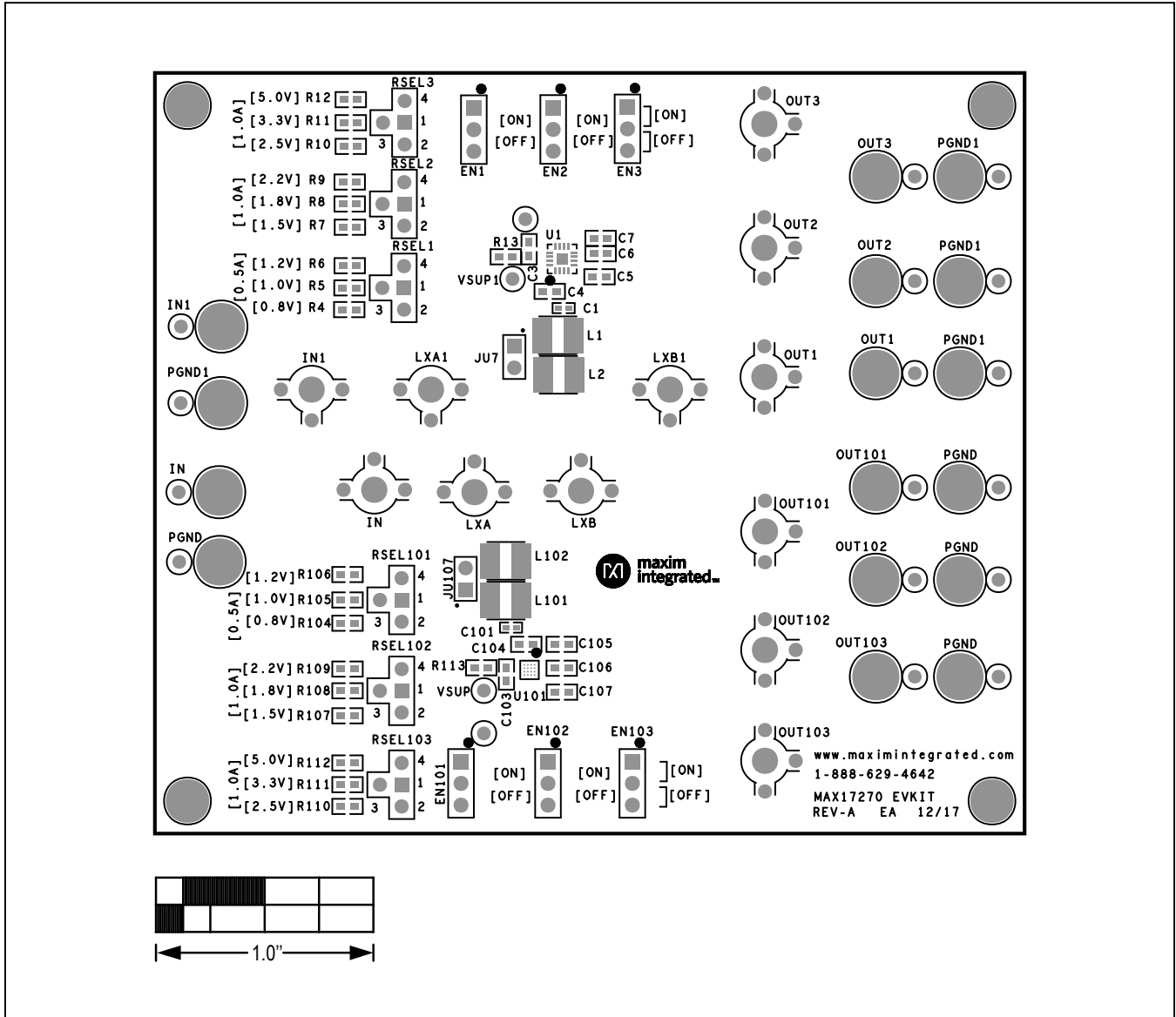

MAX17270 EV PCB—Top Silkscreen

MAX17270 EV Kit PCB Layout Diagrams (continued)

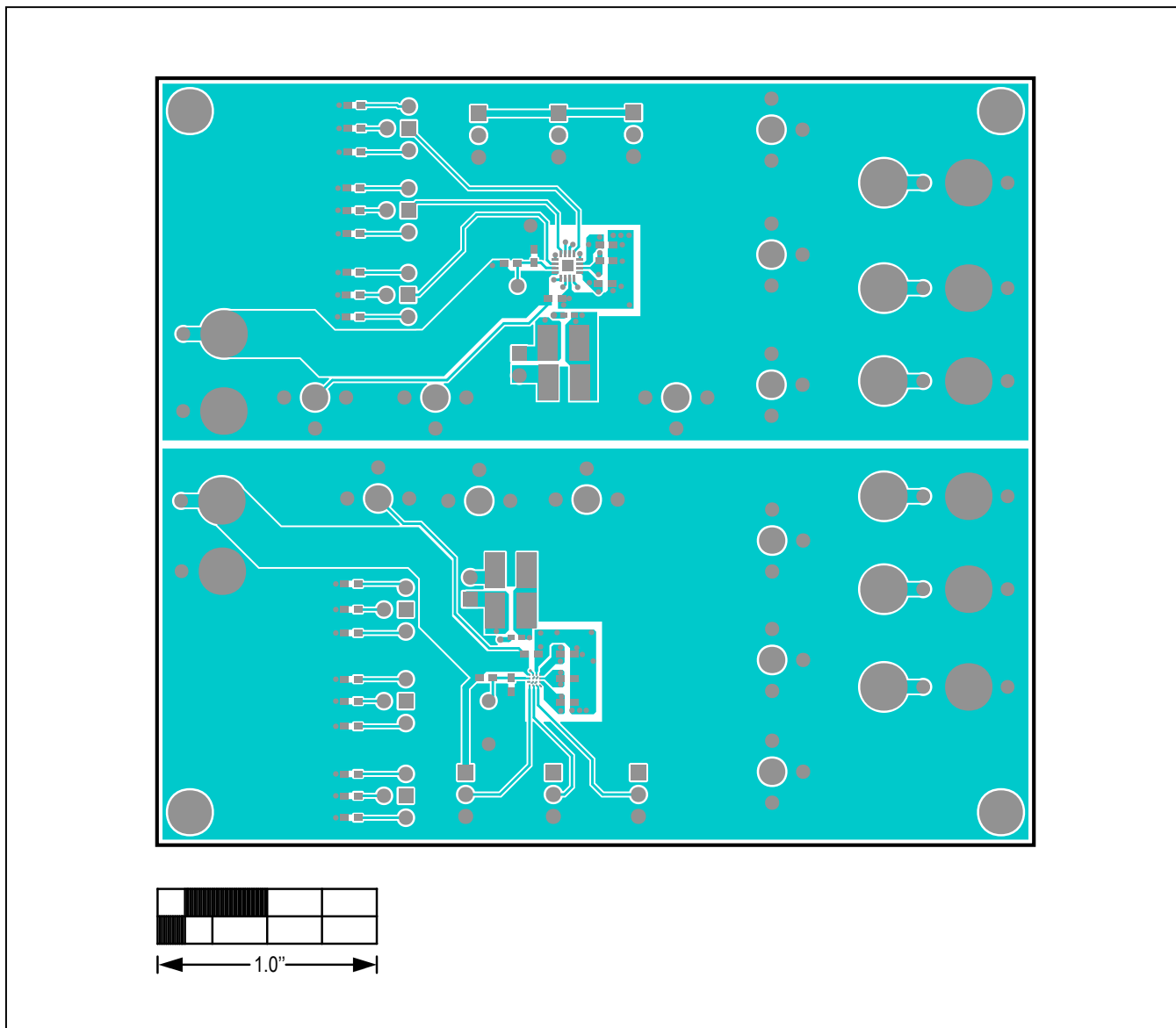

MAX17270 EV PCB—Top Layer

MAX17270 EV Kit PCB Layout Diagrams (continued)

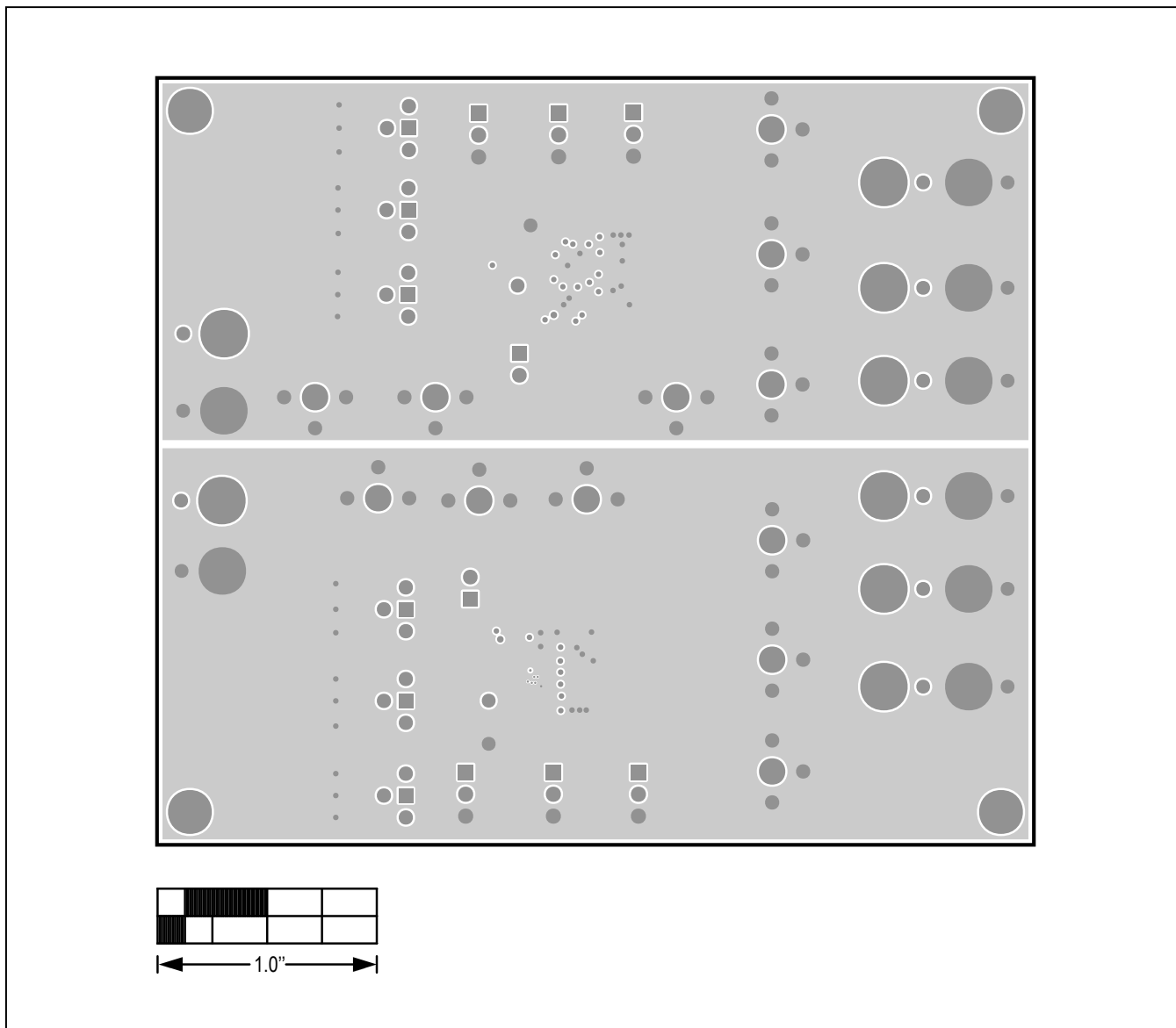

MAX17270 EV PCB—Internal 2

MAX17270 EV Kit PCB Layout Diagrams (continued)

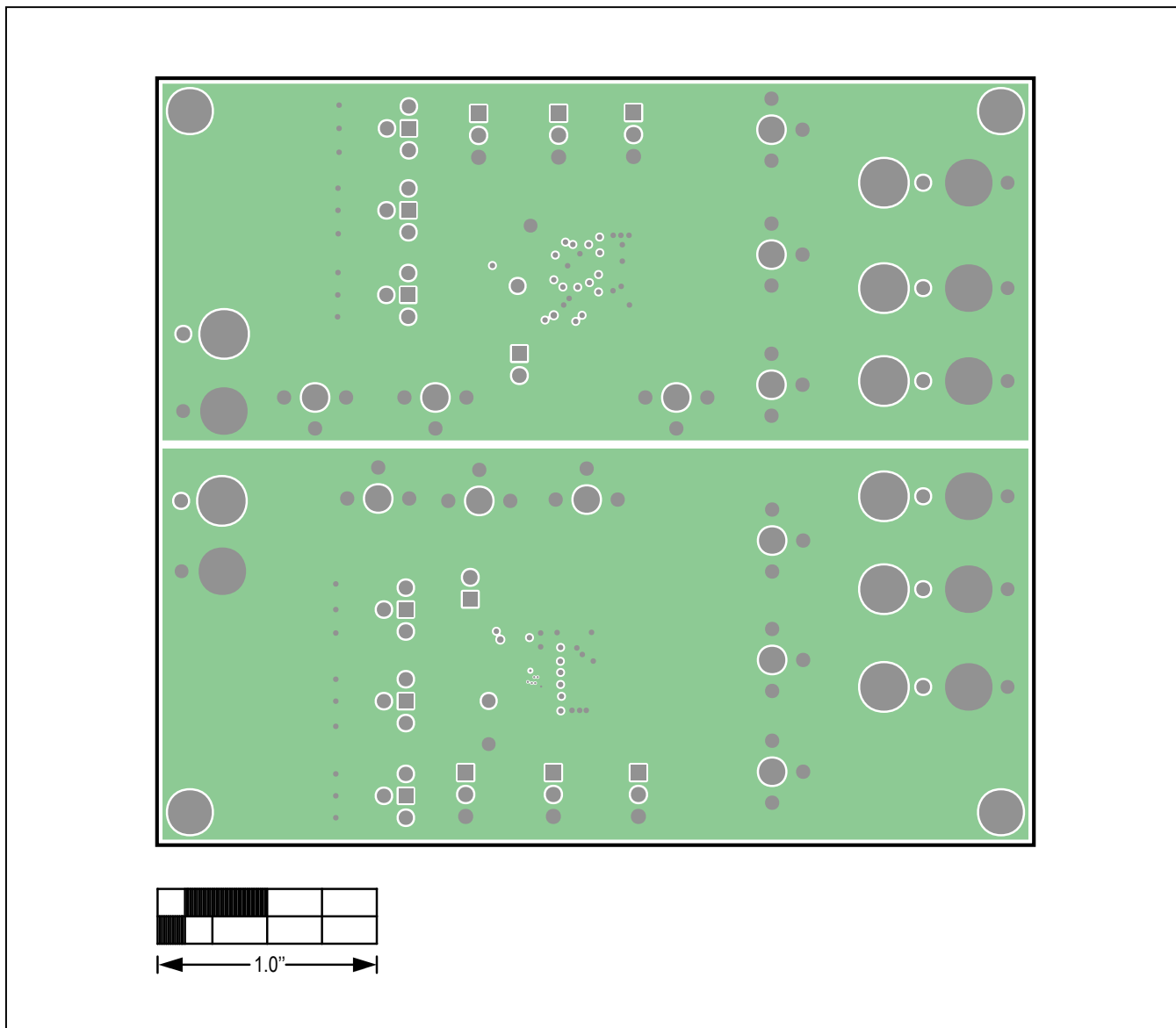

MAX17270 EV PCB—Internal 3

MAX17270 EV Kit PCB Layout Diagrams (continued)

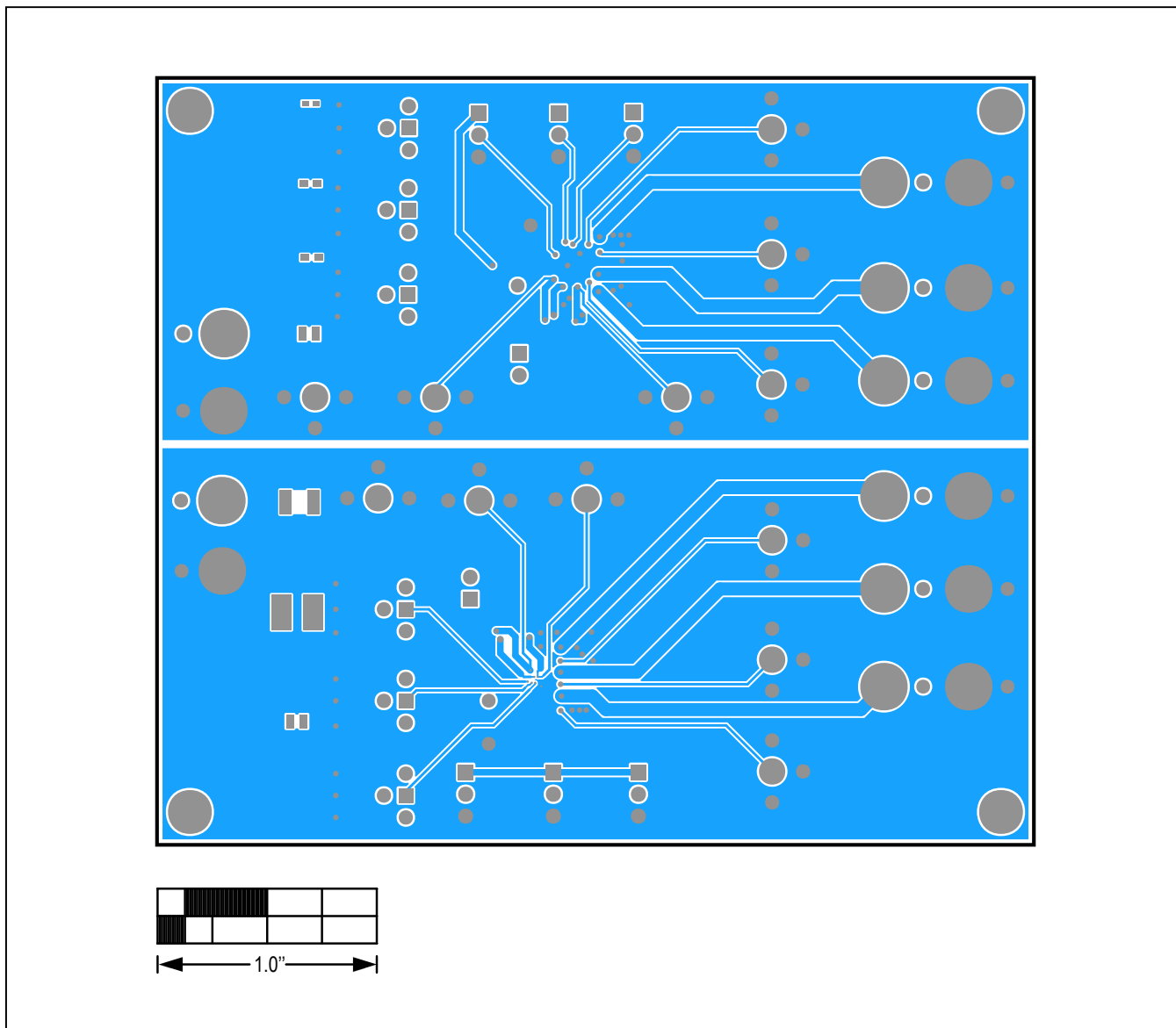

MAX17270 EV PCB—Bottom Layer

MAX17270 EV Kit PCB Layout Diagrams (continued)

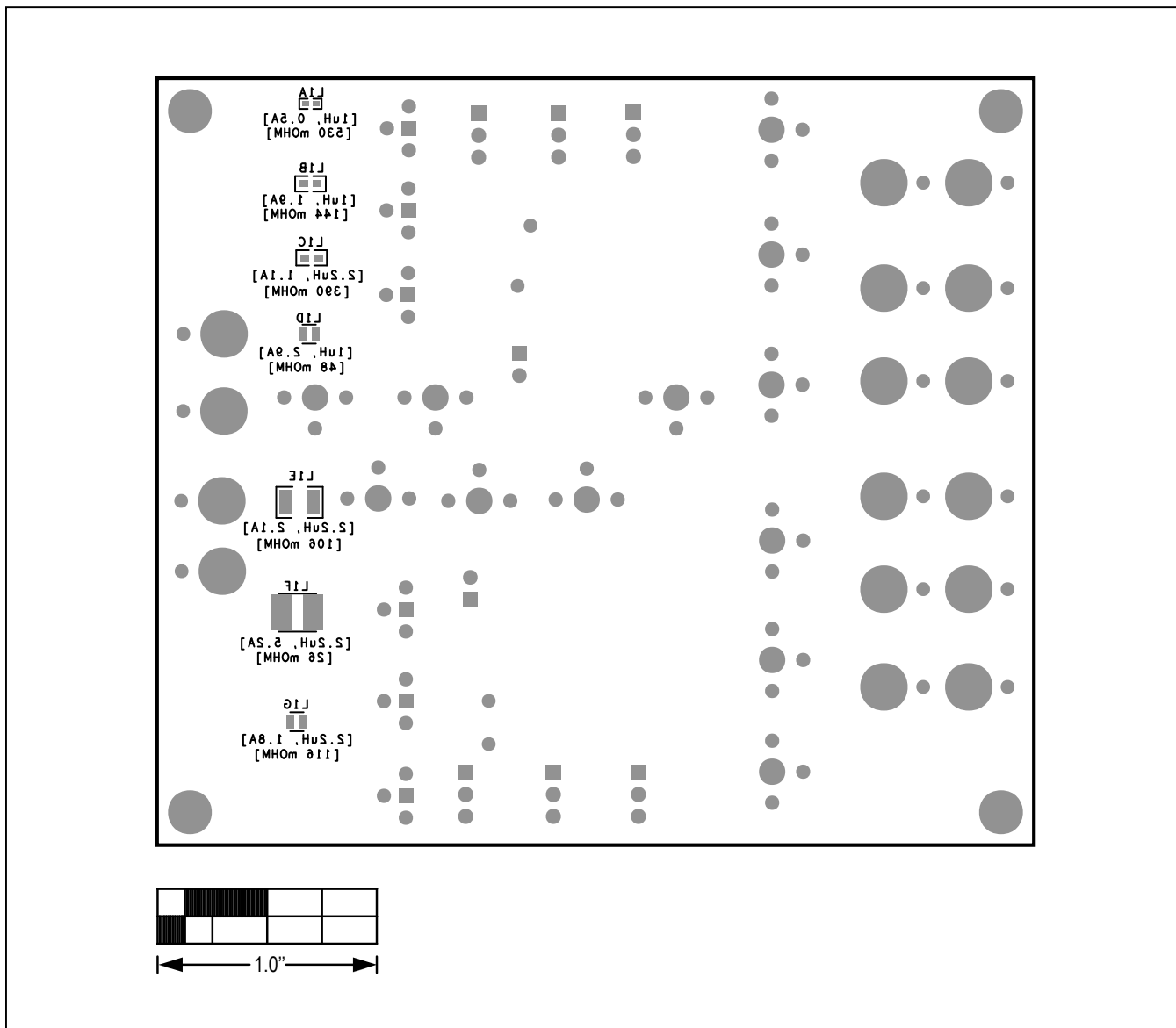

MAX17270 EV PCB—Bottom Silkscreen

Revision History

REVISION NUMBER	REVISION DATE	DESCRIPTION	PAGES CHANGED
0	2/18	Initial release	—

For pricing, delivery, and ordering information, please contact Maxim Direct at 1-888-629-4642, or visit Maxim Integrated's website at www.maximintegrated.com.

Maxim Integrated cannot assume responsibility for use of any circuitry other than circuitry entirely embodied in a Maxim Integrated product. No circuit patent licenses are implied. Maxim Integrated reserves the right to change the circuitry and specifications without notice at any time.

X-ON Electronics

Largest Supplier of Electrical and Electronic Components

Click to view similar products for [Power Management IC Development Tools](#) category:

Click to view products by [Maxim](#) manufacturer:

Other Similar products are found below :

[EVB-EP5348UI](#) [MIC23451-AAAYFL EV](#) [MIC5281YMME EV](#) [124352-HMC860LP3E](#) [DA9063-EVAL](#) [ADP122-3.3-EVALZ](#) [ADP130-0.8-EVALZ](#) [ADP130-1.8-EVALZ](#) [ADP1740-1.5-EVALZ](#) [ADP1870-0.3-EVALZ](#) [ADP1874-0.3-EVALZ](#) [ADP199CB-EVALZ](#) [ADP2102-1.25-EVALZ](#) [ADP2102-1.875EVALZ](#) [ADP2102-1.8-EVALZ](#) [ADP2102-2-EVALZ](#) [ADP2102-3-EVALZ](#) [ADP2102-4-EVALZ](#) [AS3606-DB](#) [BQ25010EVM](#) [BQ3055EVM](#) [ISLUSBI2CKIT1Z](#) [LP38512TS-1.8EV](#) [EVAL-ADM1186-1MBZ](#) [EVAL-ADM1186-2MBZ](#) [ADP122UJZ-REDYKIT](#) [ADP166Z-REDYKIT](#) [ADP170-1.8-EVALZ](#) [ADP171-EVALZ](#) [ADP1853-EVALZ](#) [ADP1873-0.3-EVALZ](#) [ADP198CP-EVALZ](#) [ADP2102-1.0-EVALZ](#) [ADP2102-1-EVALZ](#) [ADP2107-1.8-EVALZ](#) [ADP5020CP-EVALZ](#) [CC-ACC-DBMX-51](#) [ATPL230A-EK](#) [MIC23250-S4YMT EV](#) [MIC26603YJL EV](#) [MIC33050-SYHL EV](#) [TPS60100EVM-131](#) [TPS65010EVM-230](#) [TPS71933-28EVM-213](#) [TPS72728YFFEVM-407](#) [TPS79318YEQEVM](#) [UCC28810EVM-002](#) [XILINXPWR-083](#) [LMR22007YMINI-EVM](#) [LP38501ATJ-EV](#)