

# MAXIM

## MAX1737 Evaluation Kit

### General Description

The MAX1737 evaluation kit (EV kit) is an assembled and tested PC board that implements a step-down, switching lithium-ion (Li+) battery charger. It can be set to charge 1 to 4 series cells. The cell voltage can be set between 4.0V and 4.4V, using standard 1% resistors, while maintaining 1% overall regulation accuracy.

The MAX1737 detects faulty cells and terminates charging. Two capacitors are used to set the charge termination, prequalification, and fault timeout periods. Three LEDs indicate the charging status. A user-supplied thermistor can be connected to the MAX1737 EV kit to monitor battery temperature and suspend charging for over- and undertemperature conditions.

### Features

- ◆ Complete Li+ Charging Solution for 1 to 4 Cells
- ◆ Low Heat and High Efficiency
- ◆ 300kHz PWM Operation
- ◆ Up to 28V Input Voltage Range
- ◆ 28-Pin QSOP Package
- ◆ Surface-Mount Construction
- ◆ Fully Assembled and Tested

### Ordering Information

PART	TEMP. RANGE	IC PACKAGE
MAX1737EVKIT	0°C to +70°C	28 QSOP

### Component List

DESIGNATION	QTY	DESCRIPTION
C1	1	4.7 $\mu$ F, 10V X5R ceramic capacitor Taiyo Yuden LMK316BJ475ML or Murata GRM42-6X5R475K10
C2, C4, C7, C10, C11	5	0.1 $\mu$ F, 50V X7R ceramic capacitors (0805) Murata GRM40034X7R104K050 or Taiyo Yuden UMK212BJ104KG
C3	1	0.22 $\mu$ F, 50V X7R ceramic capacitor Taiyo Yuden UMK316BJ224ML
C5, C6	2	0.047 $\mu$ F, 50V X7R ceramic capacitors
C8, C9	2	0.1 $\mu$ F, 50V X7R ceramic capacitors (1206)
C12, C13, C14, C21, C22, C23	6	1000pF, 50V X7R ceramic capacitors
C15	1	68 $\mu$ F, 20V, 0.150 $\Omega$ , low-ESR tantalum capacitor AVX TPSE686M020R0150
C18, C19	2	22 $\mu$ F, 35V, 0.300 $\Omega$ , low-ESR tantalum capacitors AVX TPSE226M035R0300 or Kemet T495X226M035AS
D1, D4	2	Schottky diodes, 3A, 40V Fairchild MBRS340, General Semiconductor SS34, Motorola MBRS340, or Vishay Liteon/Diodes, Inc. B340

DESIGNATION	QTY	DESCRIPTION
D2, D3	2	Diodes 1N4148-type Fairchild MMSD4148, General Semiconductor 1N4148W, or Vishay Liteon/Diodes, Inc. 1N4148W
JU1, JU3, JU4	5	2-pin headers
JU2, JU5	2	3-pin headers
JU6	1	4-pin header
JU7, JU8	0	Not installed
L1	1	22 $\mu$ H, 2.8A inductor Sumida CDRH124-220
LED1, LED2	2	Light-emitting diodes (green)
LED3	1	Light-emitting diode (red)
N1 (N1A, N1B)	1	Dual N-channel MOSFET Fairchild FDS6990A
R1, R11	2	10k $\Omega$ $\pm$ 5% resistors
R2, R3, R4	3	1k $\Omega$ $\pm$ 5% resistors
R5–R10	6	100k $\Omega$ $\pm$ 1% resistors
R12	1	0.05 $\Omega$ $\pm$ 1%, 0.5W sense resistor Dale-Vishay WSL-2010-R050F or IRC LRC-LR2010-01-R050-F
R13, R14, R19, R20	4	4.7 $\Omega$ $\pm$ 5% resistors
R15, R17	0	Not installed
R18	1	0.1 $\Omega$ $\pm$ 1%, 0.5W sense resistor Dale-Vishay WSL-2512-R100F or IRC LRC-LR2512-01-R100-F
U1	1	MAX1737EEI
None	5	Shunts

Evaluates: MAX1737

# MAX1737 Evaluation Kit

## Quick Start

The MAX1737 EV kit is a fully assembled and tested surface-mount board. Follow the steps below to verify board operation. **Do not turn on the power supply until all connections are completed. Observe all precautions on the battery manufacturer's data sheet. Use only lithium-ion cells with this charger:**

- 1) Set jumper JU6 to indicate the number of cells in the battery pack (Table 1).
- 2) Place a shunt on jumper JU1 to disable the temperature monitoring function.
- 3) Place a shunt across pins 1-2 on JU2 to enable the MAX1737.
- 4) Place a shunt across JU3 to enable 2A charging current limit.
- 5) Place a shunt across JU4 to enable 2A input current limit.
- 6) Remove any shunt from JU5 to set the cell voltage to 4.2V. If a different battery regulation voltage is required, refer to the MAX1737 data sheet.
- 7) Connect a +7VDC to +28VDC power supply with sufficient power rating across the VIN and GND pads.
- 8) Connect a lithium-ion battery pack between the BATT+ and BATT- pads.
- 9) Turn on the power supply.
- 10) Measure the battery voltage and verify that the LEDs indicate the correct state.

## Detailed Description

When battery charging is initiated, the charger enters the prequalification state. In this state, the batteries are charged at 1/20 of the programmed current limit while the charger measures the battery to determine if it can be charged. If the battery voltage is above 2.5V per cell, charging begins. At this time, the batteries are charged at a constant current (Fast Charge state) and a constant voltage (Full Charge state). The charger exits the Full Charge state and enters the Top Off state once the battery current drops to 10% of the Fast Charge current, or the Fast Charge timer expires. The charger remains in the Top Off state for 45 minutes, at which time charging is terminated.

Once charging is terminated, if the battery voltage drops 5% from the fully charged voltage, charging automatically restarts.

If, at any time during charging, the thermistor input senses a temperature below 0°C or above +50°C, charging suspends until the temperature returns to a safe level. If the charger is unable to enter the Fast Charge or Full Charge state, charging is terminated and the Fault LED

(red) lights indicate a faulty battery. This kit is shipped with a 10kΩ resistor to disable the temperature monitoring function. If temperature monitoring is required, connect the appropriate thermistor (see *Jumper Selection* section).

For more information on the operation of the MAX1737, refer to the *Detailed Description* section of the MAX1737 data sheet.

## Charging Status

The three LEDs on the EV kit indicate the charging status:

- LED1 (FULLCHG) indicates that the battery pack is being charged with a constant voltage.
- LED2 (FASTCHG) indicates that the battery pack is being charged with a constant current.
- LED3 (FAULT) indicates that charging terminated abnormally.

## Jumper Selection

Jumper JU1 connects the MAX1737 thermistor input (THERM) to GND through a 10kΩ resistor, disabling temperature qualification. To enable temperature qualification (charging between 0°C and 50°C), remove the shunt from JU1, and connect a thermistor (BC Components part number 2322-640-63103 or equivalent) to the THERM and GND pads. For more information, refer to the MAX1737 data sheet.

The MAX1737 can be placed in shutdown mode using jumper JU2. See Table 1 for jumper settings.

Jumper JU3 sets the charging current limit (current to the battery). A shunt across this jumper limits the output current to 2A. With the shunt removed, a resistor-divider formed by R5 and R6 sets the current. The EV kit comes with the resistors selected for a 1A current limit. A different current can be selected by changing the resistors (refer to the MAX1737 data sheet).

Jumper JU4 sets the input current limit (current from the power supply). A shunt across this jumper limits the input current to 2A. With the shunt removed, a resistor-divider formed by R7 and R8 sets the current. The EV kit comes with the resistors selected for a 1A current limit. A different current can be selected by changing the resistors (refer to the MAX1737 data sheet).

Jumper JU5 sets the voltage per cell. Jumper JU6 selects the number of series cells to be charged. See Table 1 for jumper settings.

# MAX1737 Evaluation Kit

**Evaluates: MAX1737**

**Table 1. Jumper Selection**

JUMPER	JUMPER POSITION	FUNCTION
JU1	Open	Open before connecting a thermistor from THERM to GND pads.
	Closed*	Bypasses THERM with 10kΩ resistor.
JU2	1-2*	SHDN = high. MAX1737 enabled.
	2-3	SHDN = low. MAX1737 disabled.
	Open	Drive SHDN pad with an external signal.
JU3	Open	ISETOUT = REF/2. Charging current limited to 1A.
	Closed*	ISETOUT = REF. Charging current limited to 2A.
JU4	Open	ISETIN = REF/2. Input current limited to 1A.
	Closed*	ISETIN = REF. Input current limited to 2A.
JU5	1-2	VADJ = REF. Voltage per cell = 4.4V.
	2-3	VADJ = GND. Voltage per cell = 4.0V.
	Open*	VADJ = REF/2. Voltage per cell = 4.2V. Set by resistor-dividers R9 and R10.†
JU6	1-2*	CELL = GND. Cell count = 1.
	1-3	CELL = VL. Cell count = 4.
	1-4	CELL = REF. Cell count = 3.
	Open	CELL = Float. Cell count = 2.

\*Default position

†For other voltages, refer to the Setting the Battery Regulation Voltage section of the MAX1737 data sheet.

## Component Suppliers

SUPPLIER	PHONE	FAX
AVX	803-946-0690	803-626-3123
BC Components	803-772-2500	
Dale-Vishay	402-564-3131	402-563-6418
Fairchild	408-822-2000	408-822-2102
General Semiconductor	631-847-3000	631-847-3236
International Resistive Co. (IRC)	310-322-3331	310-322-3332
Kemet	408-986-0424	408-986-1442
Motorola	303-675-2140	303-675-2150
Murata	814-237-1431	814-238-0490
Sumida	847-956-0666	847-956-0702
Taiyo Yuden	408-573-4150	408-573-4159
Vishay Liteon/Diodes, Inc.	805-446-4800	805-446-4850

# MAX1737 Evaluation Kit

Evaluates: MAX1737

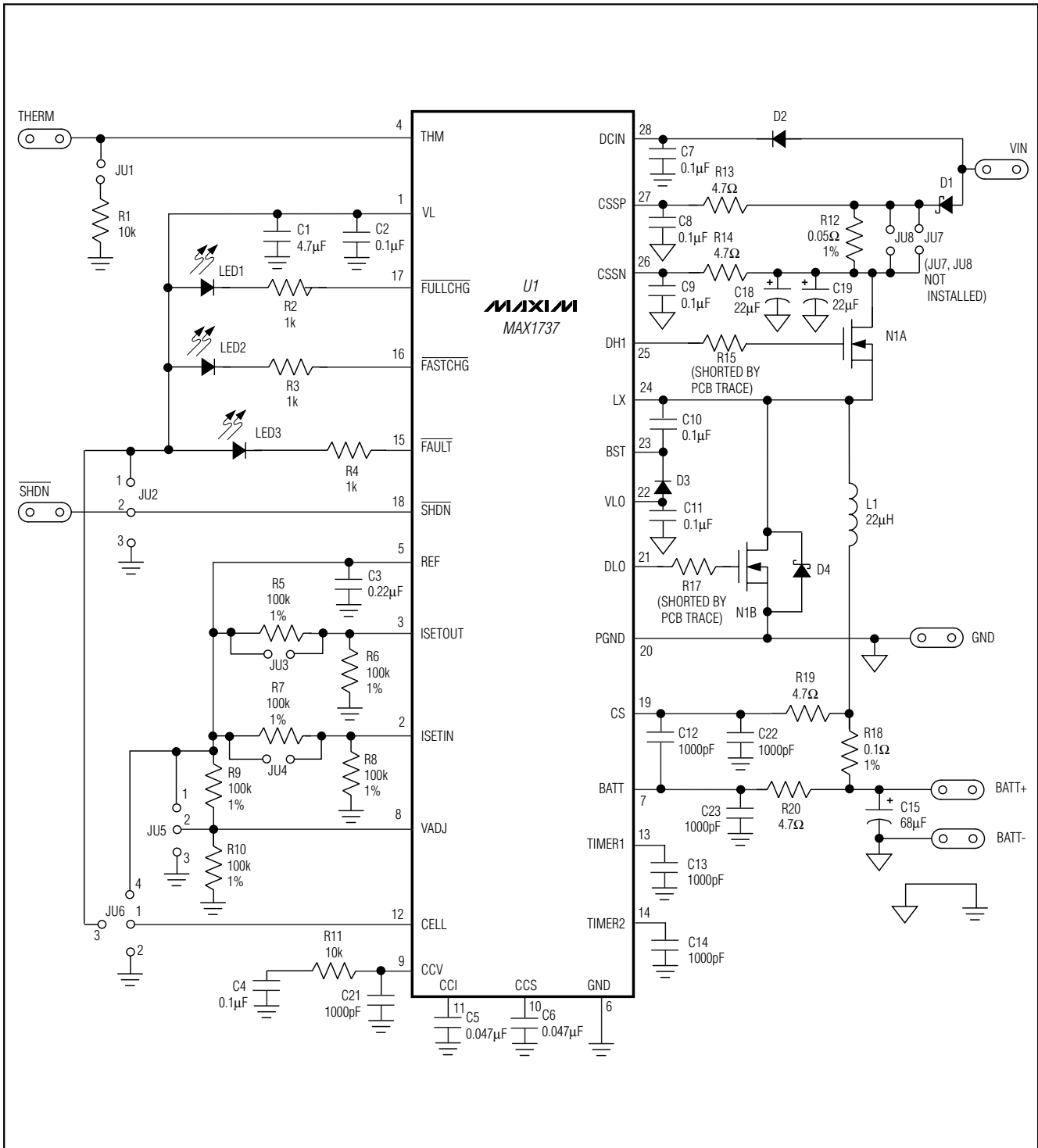

Figure 1. MAX1737 EV Kit Schematic

# MAX1737 Evaluation Kit

Evaluates: MAX1737

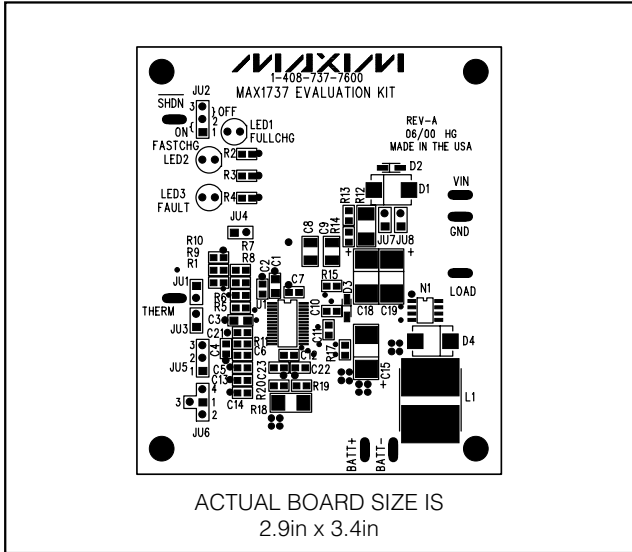

Figure 2. MAX1737 EV Kit Component Placement Guide—Component Side

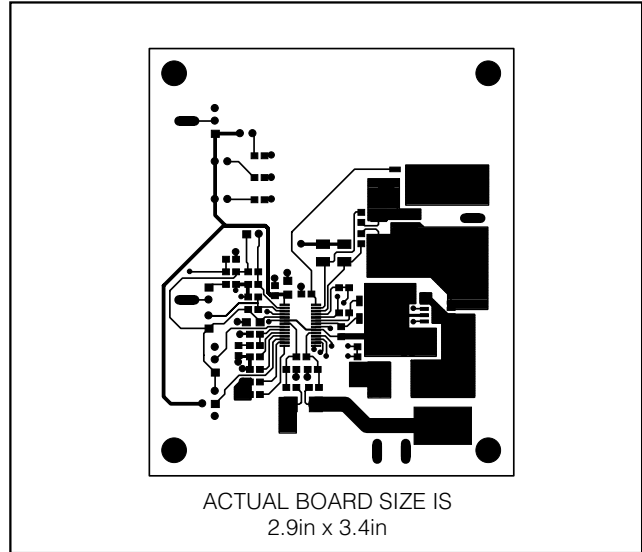

Figure 3. MAX1737 EV Kit PC Board Layout—Component Side

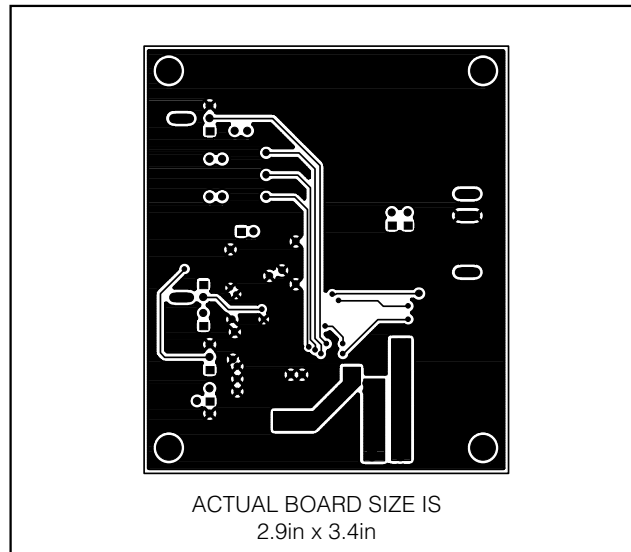

Figure 4. MAX1737 EV Kit PC Board Layout—Solder Side

Maxim cannot assume responsibility for use of any circuitry other than circuitry entirely embodied in a Maxim product. No circuit patent licenses are implied. Maxim reserves the right to change the circuitry and specifications without notice at any time.

Maxim Integrated Products, 120 San Gabriel Drive, Sunnyvale, CA 94086 408-737-7600 \_\_\_\_\_ 5

## X-ON Electronics

Largest Supplier of Electrical and Electronic Components

*Click to view similar products for [Power Management IC Development Tools](#) category:*

*Click to view products by [Maxim](#) manufacturer:*

Other Similar products are found below :

[EVB-EP5348UI](#) [MIC23451-AAAYFL EV](#) [MIC5281YMME EV](#) [124352-HMC860LP3E](#) [DA9063-EVAL](#) [ADP122-3.3-EVALZ](#) [ADP130-0.8-EVALZ](#) [ADP130-1.8-EVALZ](#) [ADP1740-1.5-EVALZ](#) [ADP1870-0.3-EVALZ](#) [ADP1874-0.3-EVALZ](#) [ADP199CB-EVALZ](#) [ADP2102-1.25-EVALZ](#) [ADP2102-1.875EVALZ](#) [ADP2102-1.8-EVALZ](#) [ADP2102-2-EVALZ](#) [ADP2102-3-EVALZ](#) [ADP2102-4-EVALZ](#) [AS3606-DB](#) [BQ25010EVM](#) [BQ3055EVM](#) [ISLUSBI2CKIT1Z](#) [LP38512TS-1.8EV](#) [EVAL-ADM1186-1MBZ](#) [EVAL-ADM1186-2MBZ](#) [ADP122UJZ-REDYKIT](#) [ADP166Z-REDYKIT](#) [ADP170-1.8-EVALZ](#) [ADP171-EVALZ](#) [ADP1853-EVALZ](#) [ADP1873-0.3-EVALZ](#) [ADP198CP-EVALZ](#) [ADP2102-1.0-EVALZ](#) [ADP2102-1-EVALZ](#) [ADP2107-1.8-EVALZ](#) [ADP5020CP-EVALZ](#) [CC-ACC-DBMX-51](#) [ATPL230A-EK](#) [MIC23250-S4YMT EV](#) [MIC26603YJL EV](#) [MIC33050-SYHL EV](#) [TPS60100EVM-131](#) [TPS65010EVM-230](#) [TPS71933-28EVM-213](#) [TPS72728YFFEVM-407](#) [TPS79318YEQEVM](#) [UCC28810EVM-002](#) [XILINXPWR-083](#) [LMR22007YMINI-EVM](#) [LP38501ATJ-EV](#)