

General Description

The MAX17497A evaluation kit (EV kit) demonstrates the MAX17497A controller IC offline AC-DC flyback converter design and features an integrated step-down regulator. The EV kit circuit uses the MAX17497AATE current-mode fixed-frequency flyback converter in a 16-pin TQFN package with an exposed pad.

The EV kit demonstrates the IC's cycle-by-cycle current limit, soft-start, and UVLO features optimized for universal offline applications (+85V AC to +265V AC). The EV kit circuit is configured for output voltages of +12V and +3.3V and provides up to 300mA and 600mA of current from the respective outputs.

The transformer secondary +12V output is used as the input source for the IC step-down regulator that provides +3.3V at VOUT2.

Warning: The EV kit is designed to operate with high voltages. Dangerous voltages are present on this EV kit and on equipment connected to it. Users who power up this EV kit or power the sources connected to it must be careful to follow safety procedures appropriate to working with high-voltage electrical equipment.

Under severe fault or failure conditions, this EV kit may dissipate large amounts of power, which could result in the mechanical ejection of a component or of component debris at high velocity. Operate this kit with care to avoid possible personal injury.

Component List

DESIGNATION	QTY	DESCRIPTION
C1, C12	2	0.1 μ F \pm 10%, 630V film capacitors Panasonic ECQ-E6104KF
C2, C3	2	100 μ F, 400V electrolytic capacitors (25mm x 25mm) Panasonic ECO-S2GP101CA
C4	1	2.2 μ F \pm 10%, 50V X7R ceramic capacitor (1206) Murata GRM31CR71H225K
C5	1	0.47 μ F \pm 10%, 50V X7R ceramic capacitor (0805) Murata GRM21BR71H474K
C6	1	0.047 μ F \pm 10%, 50V X7R ceramic capacitor (0603) Murata GRM188R71H473K

Features

- +85V AC to +265V AC Input Voltage Range
- Dual Non-Isolated Outputs
 - +12V Provides Up to 300mA (VOUT1)
 - +3.3V Provides Up to 600mA (VOUT2)
- 250kHz Switching Frequency
- RESETN Open-Drain Output
- Undervoltage Lockout (UVLO)
- Low-Cost Flyback Design
- Proven PCB Layout
- Fully Assembled and Tested

[Ordering Information](#) appears at end of data sheet.

DESIGNATION	QTY	DESCRIPTION
C7	1	2.2 μ F \pm 10%, 16V X7R ceramic capacitor (0805) Murata GRM21BR71C225K
C8	1	330pF \pm 20%, 100V X7R ceramic capacitor (0603) Murata GRM188R72A331M
C9	1	0.022 μ F \pm 10%, 25V X7R ceramic capacitor (0603) Murata GRM188R71E223K
C10	1	0.1 μ F \pm 10%, 50V X7R ceramic capacitor (0603) Murata GRM188R71H104K
C11	1	10 μ F \pm 10%, 16V X7R ceramic capacitor (1206) Murata GRM31CR71C106K

Component List (continued)

DESIGNATION	QTY	DESCRIPTION
C13	1	22 μ F \pm 10%, 25V X7R ceramic capacitor (1210) Murata GRM32ER71E226K
C14	0	Not installed, ceramic capacitor (1210)
C15	1	10 μ F \pm 10%, 25V X7R ceramic capacitor (1206) Murata GRM31CR71E106K
D1	1	1000V, 1A diode (41 DO1) Fairchild 1N4007
D2	1	100V, 300mA diode (SOD123) Diodes Inc. 1N4148W-7-F
D3	1	800V, 1A diode (SMA) Diodes Inc. US1K-TP
D4	1	18V zener diode (SOD123) Rohm BZT52C18-7-F
D5	1	200V, 1A Schottky diode (SMA) Micro Comm SS1200-LTP
D6	1	200V zener diode (SMA) Micro Comm 3SMAJ5956B
L1	1	1000 μ H, 120mA inductor (6.5mm x 6.5mm) Bourns SRR0604-102KL
L2	1	15 μ H, 1A inductor (4mm x 4mm) Coilcraft LPS4018-153ML
N1	1	800V, 1A n-channel MOSFET (DPAK) Fairchild FQD1N80TM

DESIGNATION	QTY	DESCRIPTION
N2	1	800V, 200mA n-channel MOSFET (SOT223) Fairchild FQT1N80TF-WS
Q1	1	30V, 100mA BJT transistor (SOT23) NXP Semi BC849W.115
R1–R4	4	1.2M Ω \pm 5% resistors (1206)
R5–R8	4	3M Ω \pm 5% resistors (1206)
R9–R12	4	845K Ω \pm 1% resistors (1206)
R13	1	44.2K Ω \pm 1% resistor (0603)
R14, R20, R22	3	10K Ω \pm 0.1% resistors (0603)
R15	1	27.4K Ω \pm 1% resistor (0603)
R16	1	49.9K Ω \pm 0.5% resistor (0603)
R17	1	442K Ω \pm 1% resistor (0603)
R18	1	3.32K Ω \pm 1% resistor (0603)
R19	1	10 Ω \pm 1% resistor (0603)
R21	0	Not installed, resistor (0603)
R23	1	220 Ω \pm 1% resistor (0603)
RT1	1	10 Ω current-limiting thermistor EPCOS B57153S0100M000
T1	1	1:0.25 transformer (15 EFD) Coilcraft CR8076-AL
U1	1	Offline 250kHz peak-current-mode converter (16 TQFN-EP*) Maxim MAX17497AATE+
—	1	PCB: MAX17497A EVALUATION KIT

*EP = Exposed pad.

Component Suppliers

SUPPLIER	PHONE	WEBSITE
Bourns, Inc.	408-496-0706	www.bourns.com
Coilcraft, Inc.	847-639-6400	www.coilcraft.com
Diodes Incorporated	805-446-4800	www.diodes.com
EPCOS AG	732-906-4300	www.epcos.com
Fairchild Semiconductor	888-522-5372	www.fairchildsemi.com
Murata Electronics North America, Inc.	770-436-1300	www.murata-northamerica.com
NXP Semiconductors	408-474-8142	www.nxp.com
Panasonic Corp.	800-344-2112	www.panasonic.com
ROHM Co., Ltd.	858-625-3630	www.rohm.com

Note: Indicate that you are using the MAX17497A when contacting these component suppliers.

Quick Start

Required Equipment

- MAX17497A EV kit
- AC source (+85V AC to +265V AC)
- Three voltmeters
- 300mA load
- 600mA load

Procedure

The EV kit is fully assembled and tested. Follow the steps below to verify board operation. **Warning: Exercise caution when connecting and measuring offline voltages.**

- 1) Connect the first voltmeter to the VOUT1 and PGND PCB pads.
- 2) Connect the second voltmeter to the VOUT2 and PGND PCB pads.
- 3) Connect the 300mA load to VOUT1 and PGND PCB pads.
- 4) Connect the 600mA load to VOUT2 and PGND PCB pads.
- 5) Connect the +85V AC to +265V AC power supply to the LINE and NEUTRAL PCB pads.
- 6) Turn on the AC power supply.
- 7) Verify that the voltmeter at VOUT1 reads approximately +12V.
- 8) Verify that the voltmeter at VOUT2 reads approximately +3.3V.

Detailed Description of Hardware

The MAX17497A EV kit is a 5.58W, nonisolated fly-back DC-DC converter that provides dual outputs of +12V/300mA and +3.3V/600mA at VOUT1 and VOUT2, respectively. The circuit can be powered from a +85V AC to +265V AC power source connected at the LINE and NEUTRAL PCB pads.

The transformer secondary +12V output (VOUT1) is used as the input source for the IC integrated regulator, which provides +3.3V at VOUT2.

The EV kit circuit VOUT1 voltage is set to +12V using the transformer T1 secondary output and feedback

resistors R17 and R16. Capacitor C5 sets VOUT1 soft-start to 5.6ms. VOUT2 uses the IC integrated step-down regulator, whose output is internally set to +3.3V. The VOUT2 step-down converter output has an internal 2ms soft-start time.

The IC IN pin circuit preregulation circuitry consists of transistor Q1, resistors R5–R8, capacitors C4 and C5, and diode D2 and allows the startup of the converter. During startup, when the input voltage is applied, the R5–R8 startup resistors charge the C4 and C5 startup capacitors, causing the voltage at the IN pin to increase towards the rising IN UVLO threshold (+20V typ). During this time, the IC draws a low startup current through the resistors. When the voltage at IN reaches the rising IN UVLO threshold, the IC commences switching operations and drives external MOSFET N1, whose drain is connected to the IC LXF input. Since this current cannot be supported by the current through the startup resistors, IN is bootstrapped by VOUT1. VOUT1 then provides power to IN upon reaching its regulated +12V output. If the IN voltage falls below its UVLO falling threshold (+4.5V, typ) before VOUT1 is energized, the controllers turn off and reinitiate the startup process.

The EV kit provides cycle-by-cycle primary-side current-limit protection using MOSFET N1 and the IC LXF input. Resistor R15 sets the current limit to 548mA. The EV kit features zener clamp snubber network (D6 and D3) to minimize leakage-energy ringing and clamp the voltage at the drain of MOSFET N1 during switching.

The EV kit provides VOUT1 and VOUT2 PCB pads for monitoring the circuit's outputs and various PCB pads for monitoring the circuit's inputs and outputs.

Output Voltages (VOUT1, VOUT2)

The EV kit's VOUT1 voltage is set to +12V using the T1 secondary output and feedback resistors R17 and R16.

VOUT2 is set internally to +3.3V by the IC and uses VOUT1 as its input power source.

Refer to the *Programming the Output Voltage of the Flyback/Boost Converter (SSF)* section in the MAX17497A/MAX17497B IC data sheet for additional information on setting the VOUT1 voltage.

Current Limiting

The IC features current limiting for the transformer's primary side by monitoring the peak current entering the IC LXF input. Resistor R15 sets the EV kit circuit current limit to 548mA. The IC turns off switching MOSFET N1 when the peak current at the LXF pin reaches the current limit.

To reconfigure the peak current limit to a different value, use the following equation to choose a new R15 resistor:

$$R15 = 50 \times I_{PEAK}$$

where I_{PEAK} is in amps and R15 is in $k\Omega$.

When the instantaneous peak current through the LXF pin reaches a level 20% higher than the programmed peak current limit, then the IC enters into hiccup mode, which keeps the respective converters in shutdown mode and retries after 32ms. This limits the average short-circuit current equal to:

$$I_{SS} = I_{PEAK} \times t_{SS} / (t_{SS} + t_{HICCUP})$$

where t_{HICCUP} is 32ms and t_{SS} is the short-circuit time duration.

Undervoltage (UVLO) and Overvoltage (OVI) Lockout

The EV kit features UVLO and OVI circuit protection that prevent operation below the programmed input supply start voltage. Resistors R9–R12 set the undervoltage-threshold level. Resistors R13 and R14 set the overvoltage-threshold levels. The EV kit circuit undervoltage and overvoltage are set to +78V and +422V, respectively. To reconfigure the OVLO and UVLO, refer to the *Startup Voltage and Input Overvoltage-Protection Setting (EN/UVLO, OVI)* section in the MAX17497A/MAX17497B IC data sheet.

Open-Drain Output (RESETN)

The EV kit provides a PCB pad to monitor the status of the open-drain output (RESTN). RESETN is high when VOUT is within 5% of its regulated voltage. When VOUT falls below 92% (typ) of its regulated voltage, RESETN is pulled low. RESETN is pulled up to VCC through resistor R20.

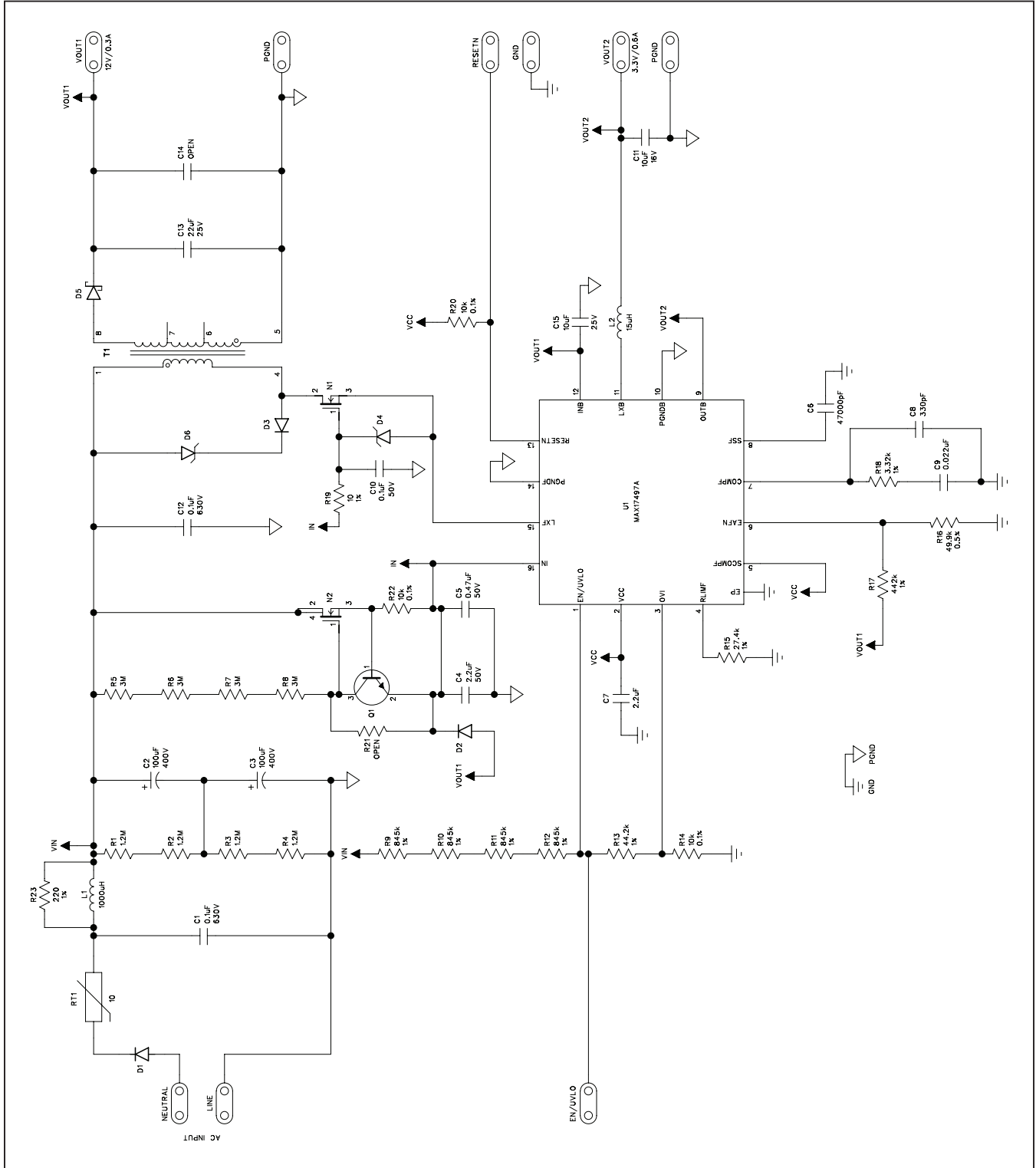

Figure 1. MAX17497A EV Kit Schematic

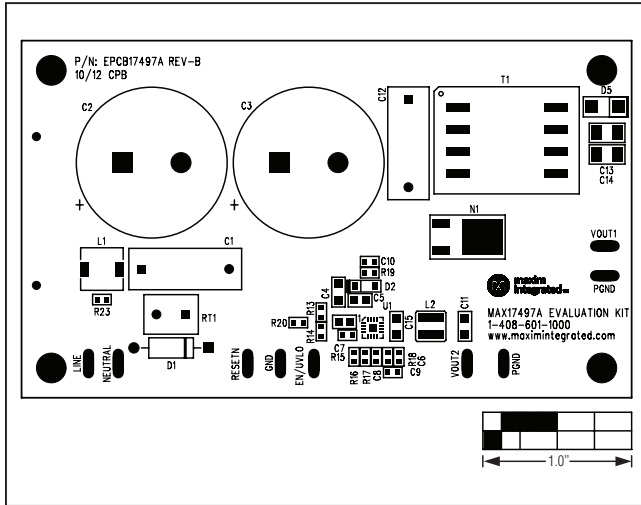

Figure 2. MAX17497A EV Kit Component Placement Guide—Component Side

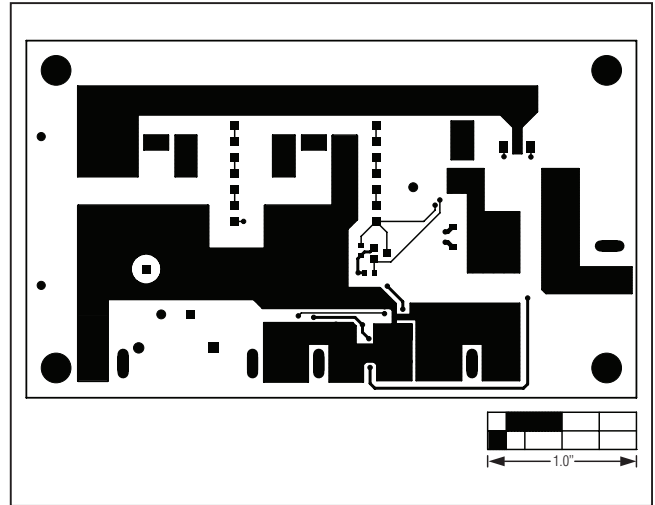

Figure 4. MAX17497A EV Kit PCB Layout—Solder Side

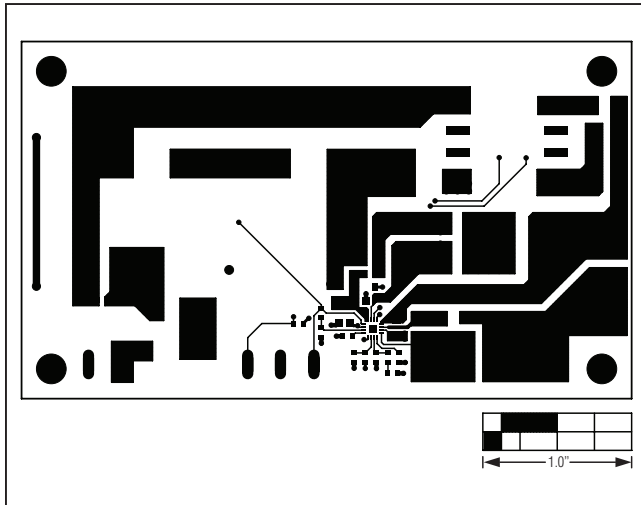

Figure 3. MAX17497A EV Kit PCB Layout—Component Side

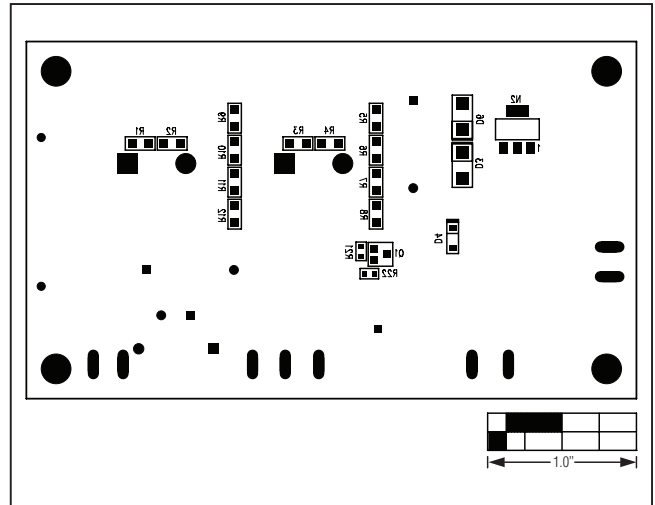

Figure 5. MAX17497A EV Kit Component Placement Guide—Solder Side

Ordering Information

PART	TYPE
MAX17497AEVKIT#	EV Kit

#Denotes RoHS compliant.

Revision History

REVISION NUMBER	REVISION DATE	DESCRIPTION	PAGES CHANGED
0	5/12	Initial release	—
1	11/12	Revised <i>Component List</i> , EV kit specifications, and Figure 1	1-6
2	8/15	Updated <i>General Description</i>	1, 3

For pricing, delivery, and ordering information, please contact Maxim Direct at 1-888-629-4642, or visit Maxim Integrated's website at www.maximintegrated.com.

Maxim Integrated cannot assume responsibility for use of any circuitry other than circuitry entirely embodied in a Maxim Integrated product. No circuit patent licenses are implied. Maxim Integrated reserves the right to change the circuitry and specifications without notice at any time.

X-ON Electronics

Largest Supplier of Electrical and Electronic Components

Click to view similar products for [Power Management IC Development Tools](#) category:

Click to view products by [Maxim](#) manufacturer:

Other Similar products are found below :

[EVB-EP5348UI](#) [MIC23451-AAAYFL EV](#) [MIC5281YMME EV](#) [124352-HMC860LP3E](#) [DA9063-EVAL](#) [ADP122-3.3-EVALZ](#) [ADP130-0.8-EVALZ](#) [ADP130-1.8-EVALZ](#) [ADP1740-1.5-EVALZ](#) [ADP1870-0.3-EVALZ](#) [ADP1874-0.3-EVALZ](#) [ADP199CB-EVALZ](#) [ADP2102-1.25-EVALZ](#) [ADP2102-1.875EVALZ](#) [ADP2102-1.8-EVALZ](#) [ADP2102-2-EVALZ](#) [ADP2102-3-EVALZ](#) [ADP2102-4-EVALZ](#) [AS3606-DB](#) [BQ25010EVM](#) [BQ3055EVM](#) [ISLUSBI2CKIT1Z](#) [LP38512TS-1.8EV](#) [EVAL-ADM1186-1MBZ](#) [EVAL-ADM1186-2MBZ](#) [ADP122UJZ-REDYKIT](#) [ADP166Z-REDYKIT](#) [ADP170-1.8-EVALZ](#) [ADP171-EVALZ](#) [ADP1853-EVALZ](#) [ADP1873-0.3-EVALZ](#) [ADP198CP-EVALZ](#) [ADP2102-1.0-EVALZ](#) [ADP2102-1-EVALZ](#) [ADP2107-1.8-EVALZ](#) [ADP5020CP-EVALZ](#) [CC-ACC-DBMX-51](#) [ATPL230A-EK](#) [MIC23250-S4YMT EV](#) [MIC26603YJL EV](#) [MIC33050-SYHL EV](#) [TPS60100EVM-131](#) [TPS65010EVM-230](#) [TPS71933-28EVM-213](#) [TPS72728YFFEVM-407](#) [TPS79318YEQEVM](#) [UCC28810EVM-002](#) [XILINXPWR-083](#) [LMR22007YMINI-EVM](#) [LP38501ATJ-EV](#)