

MAX17498BB Evaluation Kit

Evaluates: MAX17498B in a Step-Up (Boost) Configuration

General Description

The MAX17498BB evaluation kit (EV kit) is a fully assembled and tested surface-mount circuit board to evaluate the MAX17498B peak-current-mode controller in a step-up (boost) configuration. The EV kit output is configured for 24V output voltage, which can supply up to 100mA of current. The input voltage range is from 4.5V to 10V.

The EV kit features a 500kHz fixed frequency for optimum efficiency and component size. High efficiency up to 94.2% is achieved using a boost converter, providing an output power up to 2.4W.

Features

- 4.5V to 10V Input Range
- Output Voltage: 24V at 100mA
- 500kHz Switching Frequency
- Integrated n-Channel MOSFET
- Efficiency Up to 94.2%
- Resistor-Programmable UVLO/OVI Threshold
- Open-Drain Power-Good Signal (PGOOD)
- Low-Cost Boost Converter Design
- Proven PCB Layout
- Fully Assembled and Tested

[Ordering Information](#) appears at end of data sheet.

Component List

DESIGNATION	QTY	DESCRIPTION
C1	1	10 μ F \pm 20%, 25V aluminum electrolytic capacitor (4.3mm x 4.3mm) Panasonic EEE-FK1E100R
C2	1	2.2 μ F \pm 10%, 10V X7R ceramic capacitor (0805) Murata GRM21BR71A225K
C3	1	0.1 μ F \pm 10%, 16V X7R ceramic capacitor (0402) Murata GRM155R71C104K
C4	1	270pF \pm 5%, 50V C0G ceramic capacitor (0402) Murata GRM1555C1H271J
C5	1	47000pF \pm 10%, 16V X7R ceramic capacitor (0402) Murata GRM155R71C473K
C6	1	2.2 μ F \pm 10%, 50V X7R ceramic capacitor (1206) Murata GRM31CR71H225K
C7	1	1 μ F \pm 10%, 25V X7R ceramic capacitor (0805) Murata GRM21BR71E105K

DESIGNATION	QTY	DESCRIPTION
D1	1	40V, 1A Schottky diode (SOD123) Central Semi CMMSH1-40
L1	1	56 μ H, 0.75A inductor (6mm x 6mm) Coilcraft LPS6235-563ML
R1	1	43.2k Ω \pm 1% resistor (0402)
R2	1	71.5k Ω \pm 0.1% resistors (0402)
R3	1	374k Ω \pm 1% resistor (0402)
R4	1	20k Ω \pm 1% resistor (0402)
R5	1	2.37k Ω \pm 1% resistor (0402)
R6, R8	2	0 Ω \pm 5% resistors (0402)
R7	0	Not installed, resistor (0402)
R9	1	10k Ω \pm 5% resistor (0402)
U1	1	Peak-current-mode, boost regulator (16 TQFN-EP*) Maxim MAX17498BATE+
—	1	PCB: MAX17498BB EVALUATION KIT

*EP = Exposed pad.

Component Suppliers

SUPPLIER	PHONE	WEBSITE
Coilcraft, Inc.	847-639-6400	www.coilcraft.com
Central Semiconductor Corp	631-435-1110	www.centralsemi.com
Murata Electronics North America, Inc.	770-436-1300	www.murata-northamerica.com
Panasonic Corp	800-344-2112	www.panasonic.com

Note: Indicate that you are using the MAX17498BATE+ when contacting these component suppliers.

Quick Start

Required Equipment

- MAX17498BB EV kit
- 4.5V to 10V, 600mA DC power supply
- Voltmeter

VOUT Setup Procedure

The EV kit is fully assembled and tested. Follow the steps below to verify board operation:

- 1) Connect the positive lead of the DC voltmeter to the VOUT PCB pad.
- 2) Connect the negative lead of the DC voltmeter to the PGND PCB pad.
- 3) Set the DC power-supply output to 5V. Disable the power supply.
- 4) Connect the power-supply positive terminal to the VIN PCB pad.
- 5) Connect the power-supply negative terminal to the PGND PCB pad.
- 6) Enable the power supply.
- 7) Verify that VOUT is 24V throughout the 4.5V to 10V input voltage range.

Detailed Description

The MAX17498BB EV kit provides a proven design to evaluate the MAX17498B high-efficiency step-up DC-DC converter in a space-saving 16-pin TQFN package. The EV kit is configured for a 24V output voltage that can supply up to 100mA of current. The EV kit features a 500kHz fixed switching frequency for optimum efficiency and component size.

This EV kit uses the device, a peak-current-mode, pulse-width modulating (PWM) regulator with an integrated

switch. This PWM controller varies the duty cycle to compensate for the variation in input voltage and the output load to maintain a constant output voltage. The duty cycle determines the on/off duration of the internal switch. The duty cycle is controlled by the feedback loop consisting of voltage-divider resistors (R3, R4), internal error amplifier, compensation components (R5, C3, C4), and the PWM comparator inside the device.

The EV kit sets the peak inductor current-limit threshold to 864mA using resistor R1. Capacitor C5 sets VOUT soft-start to 5.7ms.

Current Limit

Resistor R1 sets the EV kit's inductor peak-current limit to 864mA. The device turns off its internal switch when the peak current reaches the current limit. To reconfigure the peak current limit to a different value, use the following equation to choose a new value for R1:

$$R1 = 50 \times I_{PK} k\Omega$$

where I_{PK} is the peak inductor current in amps.

Undervoltage Lockout and Overvoltage Protection

The EV kit features a UVLO and OVI circuit that prevent operation below the programmed input-supply startup voltage and above the overvoltage threshold. Resistors R6–R8 set the undervoltage and overvoltage thresholds. With 0Ω resistors in the place of R6 and R8, the undervoltage threshold is set at 4.5V (typ) and the overvoltage detection is disabled. To reconfigure the UVLO and OVI voltages, refer to the *Startup Voltage and Input Overvoltage-Protection Setting (EN/UVLO, OVI)* section in the MAX17498B IC data sheet

EN/UVLO and OVI PCB pads are available for monitoring the voltages present at the respective inputs.

MAX17498BB Evaluation Kit

Evaluates: MAX17498B in a Step-Up (Boost) Configuration

Soft-Start

The EV kit provides an option to configure the circuit soft-start. Capacitor C5 configures the soft-start time (t_{SS}) to 5.7ms. To reconfigure the soft-start time to a different value, use the following equation to choose a new C5 value:

$$C5 = 8.13 \times t_{SS} \text{ nF}$$

where t_{SS} is expressed in ms.

Slope Compensation

Slope compensation is necessary for stable operation of the device when operated at a duty cycle greater than 50%, in addition to the loop compensation required for small-signal stability. The EV kit operates at a maximum steady state duty cycle of 82%. To reconfigure the slope compensation to a different value, use the following equation to choose a new R2 resistor:

$$R2 = 0.5 \times S_E \text{ k}\Omega$$

where R2 is in k Ω and S_E is in mV/ μ s.

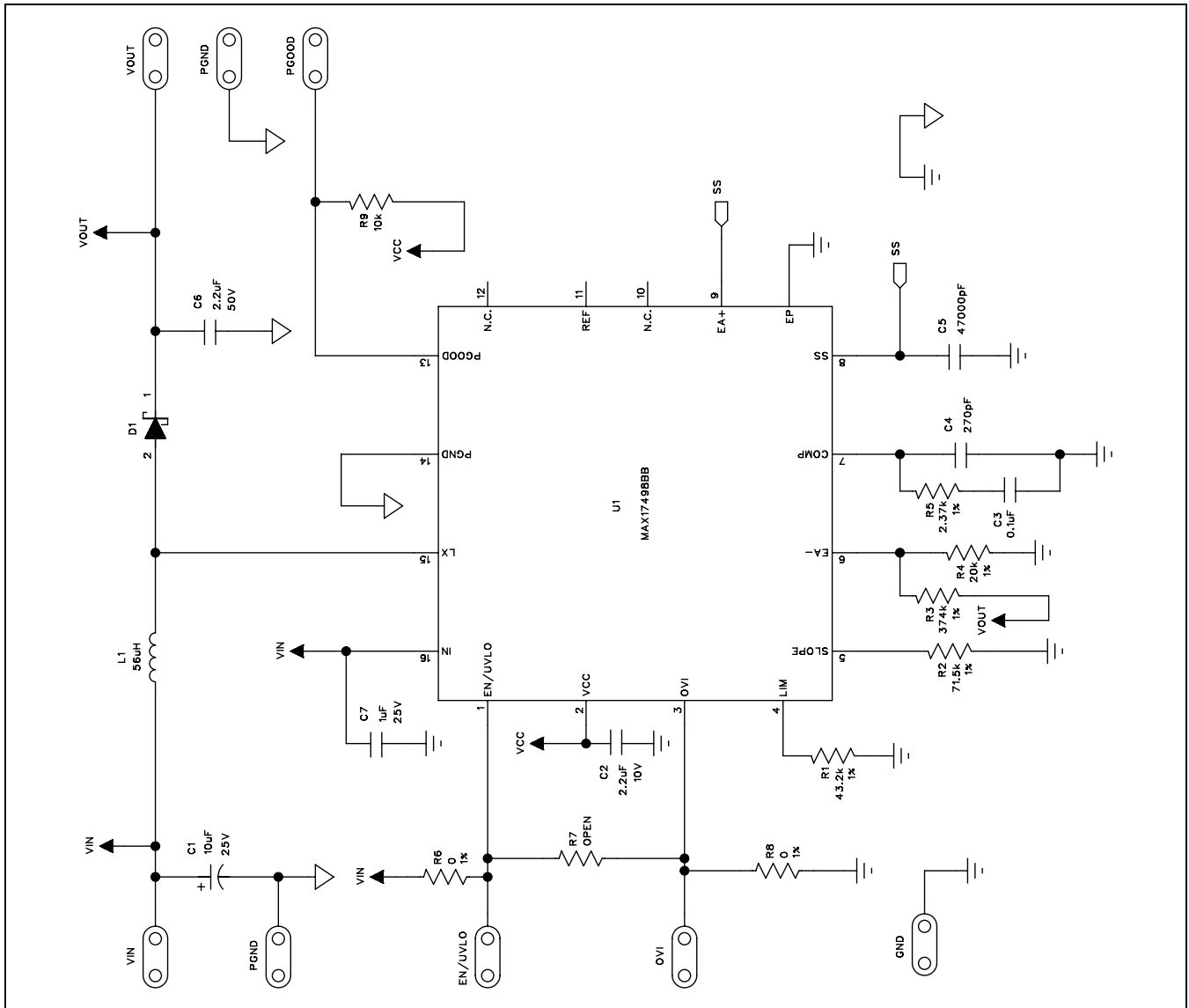

Figure 1. MAX17498BB EV Kit Schematic

MAX17498BB
Evaluation Kit

Evaluates: MAX17498B in a
Step-Up (Boost) Configuration

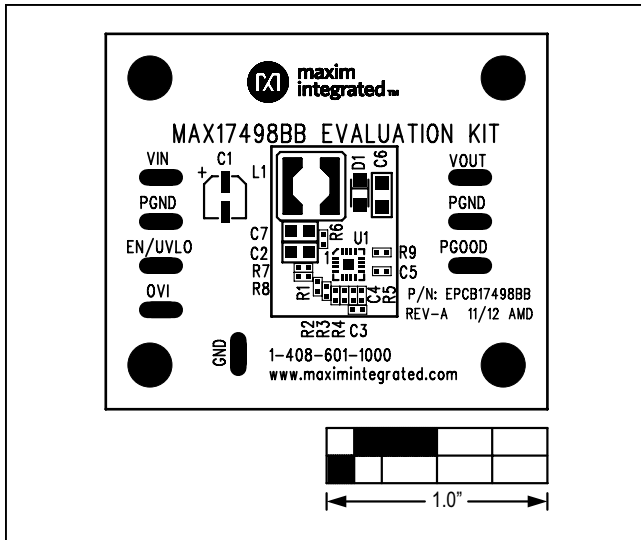

Figure 2. MAX17498BB EV Kit Component Placement Guide—Component Side

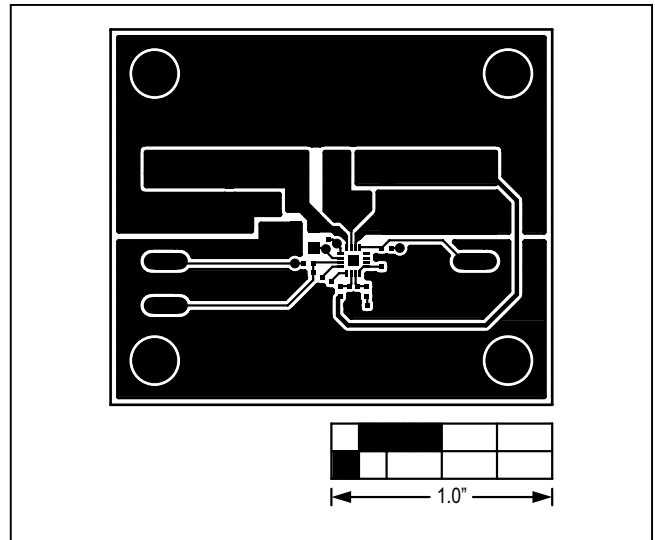

Figure 3. MAX17498BB EV Kit PCB Layout—Component Side

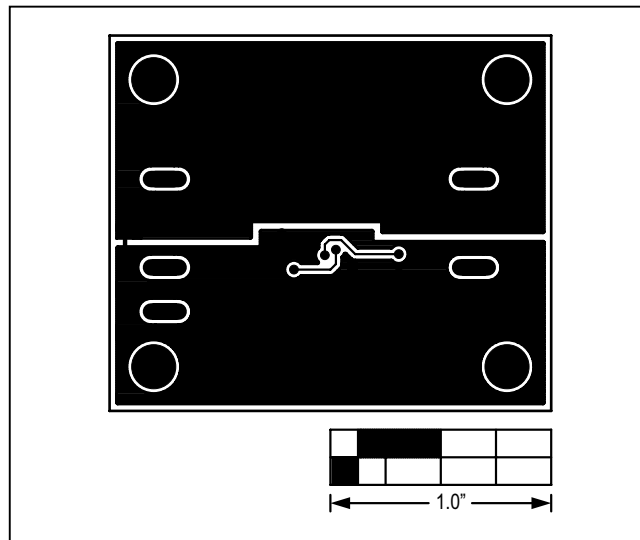

Figure 4. MAX17498BB EV Kit PCB Layout—Solder Side

MAX17498BB
Evaluation Kit

Evaluates: MAX17498B in a
Step-Up (Boost) Configuration

Ordering Information

PART	TYPE
MAX17498BBEVKIT#	EV Kit

#Denotes RoHS compliant.

MAX17498BB
Evaluation Kit

Evaluates: MAX17498B in a
Step-Up (Boost) Configuration

Revision History

REVISION NUMBER	REVISION DATE	DESCRIPTION	PAGES CHANGED
0	1/13	Initial release	—

For pricing, delivery, and ordering information, please contact Maxim Direct at 1-888-629-4642, or visit Maxim Integrated's website at www.maximintegrated.com.

Maxim Integrated cannot assume responsibility for use of any circuitry other than circuitry entirely embodied in a Maxim Integrated product. No circuit patent licenses are implied. Maxim Integrated reserves the right to change the circuitry and specifications without notice at any time.

X-ON Electronics

Largest Supplier of Electrical and Electronic Components

Click to view similar products for [Power Management IC Development Tools](#) category:

Click to view products by [Maxim](#) manufacturer:

Other Similar products are found below :

[EVB-EP5348UI](#) [MIC23451-AAAYFL EV](#) [MIC5281YMME EV](#) [124352-HMC860LP3E](#) [DA9063-EVAL](#) [ADP122-3.3-EVALZ](#) [ADP130-0.8-EVALZ](#) [ADP130-1.8-EVALZ](#) [ADP1740-1.5-EVALZ](#) [ADP1870-0.3-EVALZ](#) [ADP1874-0.3-EVALZ](#) [ADP199CB-EVALZ](#) [ADP2102-1.25-EVALZ](#) [ADP2102-1.875EVALZ](#) [ADP2102-1.8-EVALZ](#) [ADP2102-2-EVALZ](#) [ADP2102-3-EVALZ](#) [ADP2102-4-EVALZ](#) [AS3606-DB](#) [BQ25010EVM](#) [BQ3055EVM](#) [ISLUSBI2CKIT1Z](#) [LP38512TS-1.8EV](#) [EVAL-ADM1186-1MBZ](#) [EVAL-ADM1186-2MBZ](#) [ADP122UJZ-REDYKIT](#) [ADP166Z-REDYKIT](#) [ADP170-1.8-EVALZ](#) [ADP171-EVALZ](#) [ADP1853-EVALZ](#) [ADP1873-0.3-EVALZ](#) [ADP198CP-EVALZ](#) [ADP2102-1.0-EVALZ](#) [ADP2102-1-EVALZ](#) [ADP2107-1.8-EVALZ](#) [ADP5020CP-EVALZ](#) [CC-ACC-DBMX-51](#) [ATPL230A-EK](#) [MIC23250-S4YMT EV](#) [MIC26603YJL EV](#) [MIC33050-SYHL EV](#) [TPS60100EVM-131](#) [TPS65010EVM-230](#) [TPS71933-28EVM-213](#) [TPS72728YFFEVM-407](#) [TPS79318YEQEVM](#) [UCC28810EVM-002](#) [XILINXPWR-083](#) [LMR22007YMINI-EVM](#) [LP38501ATJ-EV](#)