

# MAX17561 Evaluation Kit

# Evaluates: MAX17561, MAX17562, and MAX17563—Highly Integrated, Adjustable Overcurrent and Overvoltage Protection Solutions

## General Description

The MAX17561 evaluation kit (EV kit) is a fully assembled and tested circuit board that demonstrates the MAX17561 adjustable overvoltage and overcurrent protector in a 14-pin TSSOP surface-mount package with an exposed pad. The EV kit features TVS diode on input, schottky diode on output and jumper-configurable SET1 resistors for setting different current limits. Input power to the EV kit uses a 4.5V to 36V input supply.

The EV kit can also be used to evaluate MAX17562 and MAX17563 devices by replacing the appropriate IC (U1). Request free samples from the factory when ordering the EV kit.

## Features

- 4.5V to 36V Operating Voltage Range
- Features TVS Diode and Schottky Diode
- Jumper-Configurable Current Limit
- Proven PCB Layout
- Fully Assembled and Tested

Ordering Information appears at end of data sheet.

## Quick Start

### Required Equipment

- MAX17561 EV kit
- 36V DC power supply
- Multimeter
- USB type-A to USB type-B cable or 5V DC power supply

### Procedure

The EV kit is fully assembled and tested. Perform the following steps to verify board operation. **Caution: Do not turn on the power supply until all connections are completed.**

- 1) Verify that all jumpers are in their default positions.
- 2) Connect the USB cable to J1 from a computer or connect a 5V DC power supply to TP3.
- 3) Verify that LED1 is on.
- 4) Connect a 20V DC power supply to IN. Verify that OUT is 20V.
- 5) Gradually increase the DC power supply voltage and verify that OUT voltage goes down and LED2 is ON when input reached approximately 33V.
- 6) Gradually decrease voltage on the DC power supply and verify that OUT comes back and LED2 is OFF when the input reaches approximately 32V.

## MAX17561 Evaluation Kit

## Evaluates: MAX17561, MAX17562, and MAX17563—Highly Integrated, Adjustable Overcurrent and Overvoltage Protection Solutions

### Detailed Description of Hardware

The MAX17561 EV kit is a fully assembled and tested circuit board that demonstrates the MAX17561 adjustable overvoltage and overcurrent protector in a 14-pin TSSOP-EP surface-mount package.

The jumper configurations by default are configured to test internal UVLO and internal OVLO thresholds. There are jumpers that can be configured and resistor pads to test user-defined UVLO and OVLO thresholds. The overcurrent threshold is determined by external resistors connected to the SET1 pin and is jumper configurable through jumper JU1. The EV kit also features an LED to indicate the power for logic pins.

### External Power Supply

The EV kit is powered by a user-supplied 4.5V to 36V DC power supply connected between BP1 (INPUT POWER) and GND.

### Current Limit Threshold

The EV kit features a jumper (JU1) to select current-limit threshold. Install a jumper as shown in [Table 2](#) to change the current-limit threshold.

Use the following equation to calculate the current limit:

$$R_{SET1}(k\Omega) = \frac{11500}{I_{LIM}}(mA)$$

### Overvoltage Lockout (OVLO)

Jumper JU4 (shunted by default) connects the OVLO pin to GND and configures the device to have the internal 33V preset OVLO. To configure a user-defined OVLO, disconnect JU4 and connect a shunt on jumper JU5. This allows the device to monitor the IN voltage. Connect a resistor on R12 to set the user-defined OVLO threshold.

Use the following equation to set the OVLO threshold:

$$V_{OVLO} = V_{BG} \times \left[ 1 + \frac{R11}{R12} \right]$$

where:

R11 is 2.2M $\Omega$

V<sub>BG</sub> is 1.21V

External LED2 indicates that an OVLO fault has occurred.

### Undervoltage Lockout (UVLO)

Jumper JU3 (shunted by default) connects the UVLO pin to GND and configures the device to have the internal 19.2V preset UVLO. To configure a user-defined UVLO, disconnect JU3 and connect a shunt on JU5. This allows the device to monitor the IN voltage. Connect a resistor on R10 to set the user-defined UVLO threshold. Use the following equation to set the UVLO threshold:

$$V_{UVLO} = V_{BG} \times \left[ 1 + \frac{R9}{R10} \right]$$

where:

R9 is 2.2M $\Omega$

V<sub>BG</sub> is 1.21V

### Enable (J1)

To enable the device, connect a USB connector from the computer to the USB connector, J1. This provides 5V to VBUS and to the EN pin (JU8 connects VBUS to IN by default). If no cable is available, connect a 5V DC power supply between test point TP3 and the corresponding GND test point, TP4.

### Negative Input Test

When applying a negative input to V<sub>IN</sub>, the negative input test should be performed when the output capacitors are fully discharged and VBUS should not be supplied.

**Table 1. Default Jumper Settings (JU1–JU11, JU13)**

JUMPER	SHUNT POSITION	DESCRIPTION
JU1	1-2*	Sets current threshold to 0.709A.
	3-4	Sets current threshold to 2.304A.
	5-6	Sets current threshold to 4.197A.
	7-8	Adjustable current limit using a potentiometer.
JU2	1-2	Connects the SETI pin to GND, asserts the $\overline{\text{FLAG}}$ output, and sets the current limit to 0A.
	Open*	Allows the user to connect JU1 shunts to configure the current limit.
JU3	1-2*	Connects the UVLO pin to GND and enables the internal UVLO threshold.
	Open	Allows the user to connect an external resistor-divider to set a user-defined UVLO threshold. <b>Note:</b> JU5 should also be connected.
JU4	1-2*	Connects the OVLO pin to GND and enables the internal OVLO threshold.
	Open	Allows the user to connect an external resistor-divider to set a user-defined OVLO threshold. <b>Note:</b> JU5 should also be connected.
JU5	1-2	Allows the user to connect an external resistor-divider to set a user-defined OVLO and UVLO threshold.
	Open*	Connect JU3 and JU4 or connect an external resistor-divider for normal UVLO/OVLO operation.
JU6	1-2	Connects $\overline{\text{HVEN}}$ to $V_{\text{IN}}$ and disables the device.
	Open*	If open, connect JU7.
JU7	1-2*	Connects $\overline{\text{HVEN}}$ to GND for normal operation.
	Open	If open, connect JU6.
JU8	1-2*	Connects EN to VBUS and enables the device for normal operation.
	Open	Disables the device.
JU9	1-2	Disables reverse-current flow protection.
	Open*	Enables reverse-current flow protection.
JU10	1-2*	Allows LED2 to indicate a $\overline{\text{FLAG}}$ fault.
	Open	Use external circuitry to connect to the $\overline{\text{FLAG}}$ output.
JU11	1-2	Connects OUT to IN.
	Open*	Normal operation.
JU13	1-2	Adds 2 330 $\mu$ F capacitors to OUT.
	Open*	Normal operation.

\*Default position.

**Table 2. Current-Limit/Threshold Setting (JU1)**

SHUNT POSITION	RSETI	ILIM (mA)
1-2	16.2k $\Omega$	709mA
3-4	4.99k $\Omega$	2.304A
5-6	2.74k $\Omega$	4.197A
7-8	1k $\Omega$ + 25k $\Omega$ (Adjustable pot)	Adjustable

## MAX17561 Evaluation Kit

Evaluates: MAX17561, MAX17562, and  
MAX17563—Highly Integrated, Adjustable  
Overcurrent and Overvoltage Protection Solutions

### Component Suppliers

SUPPLIER	WEBSITE
FCI (Berg Electronics)	<a href="http://www.fciconnect.com">www.fciconnect.com</a>
Keystone Electronics Corp.	<a href="http://www.keyelco.com">www.keyelco.com</a>
Lumex Inc.	<a href="http://www.lumex.com">www.lumex.com</a>
Murata Electronics North America, Inc.	<a href="http://www.murata-northamerica.com">www.murata-northamerica.com</a>
Panasonic Corp.	<a href="http://www.panasonic.com">www.panasonic.com</a>
STMicroelectronics	<a href="http://www.us.st.com">www.us.st.com</a>
Sullins	<a href="http://www.vishay.com">www.vishay.com</a>

**Note:** Indicate that you are using the MAX17561 when contacting these component suppliers.

### Ordering Information

PART	TYPE
MAX17561EVKIT#	EV Kit

#Denotes RoHS compliant.

# MAX17561 Evaluation Kit

Evaluates: MAX17561, MAX17562, and  
MAX17563—Highly Integrated, Adjustable  
Overcurrent and Overvoltage Protection Solutions

## Component List

PART REFERENCE	QTY	DESCRIPTION	MANUFACTURE PART NUMBER
C1	1	1uF 10%, 25V X7R ceramic capacitors (0603)	Murata GRM188R71E105K
C2	1	0.1uF 10%, 25V X7R ceramic capacitors (0603)	Murata GRM188R71E104K
C3	1	0.47uF 10%, 50V X7R ceramic capacitors (0603)	TDK C1608X5R1H474K
C4	1	4.7uF 10%, 50V X7R ceramic capacitors (1206)	Murata GRM31CR71H475K
C5, C6, C7, C8	4	330uF 20%, 50V aluminum (12.5mm)	Panasonic EEVFK1H331Q
D1	1	Power Schottky Diode, 60V, 5A (SMC)	STMicroelectronics STPS5L60S
D2	1	TVS Diode, 600W (SMB)	STMicroelectronics SM6T36CA
J1	1	USB B connector	FCI 61729-0010BLF
JU1	1	2x4 Dual-Row Header, 0.1in centers, cut to fit	Sullins Connector PEC36DAAN
JU2-JU11, JU13	11	2-Pin Single-Row Header, 0.1in centers, cut to fit	Sullins Connector PEC36SAAN
LED1	1	Green LED (1206)	Lumex SML-LX1206GW-TR
LED2	1	Red LED (1206)	Lumex SML-LX1206IC-TR
R1, R3, R15	3	1k ohm 5% resistors (0805)	-
R2	1	10k ohm 5% resistors (0805)	-
R4, R13, R14, R17	4	100k ohm 5% resistors (0805)	-
R6	1	16.2k ohm 1% resistor (0805)	-
R7	1	4.99k ohm 1% resistor (0805)	-
R8	1	2.74k ohm 1% resistor (0805)	-
R9, R11	2	2.2M ohm 1% resistor (0805)	-
R16	1	25k ohm Trimmer Potentiometers	Murata PV37Y253C01B00
TP1, TP9, TP10, TP11, TP12, TP13	6	Yellow Test Point	Keystone Electronic Corp 5014
TP2, TP4, TP5, TP7	4	Black Test Point	Keystone Electronic Corp 5011
TP3, TP6, TP8	3	Red Test Point	Keystone Electronic Corp 5010
U1	1	Overvoltage and Overcurrent Protector (14-pin SSOP-EP, 5mm x 6.5mm)	MAX17561AUD+
U2	1	Dual Buffer (6-pin SC70, 1.25mm Wide)	Fairchild Semiconductor NC7WZ07P6X
R5, R10, R12	0	Not Installed, (0805) Resistor	-
PCB	1	PCB:MAX17561 Evaluation Kit	-

# MAX17561 Evaluation Kit

Evaluates: MAX17561, MAX17562, and  
MAX17563—Highly Integrated, Adjustable  
Overcurrent and Overvoltage Protection Solutions

## MAX17561 EV Kit Schematic

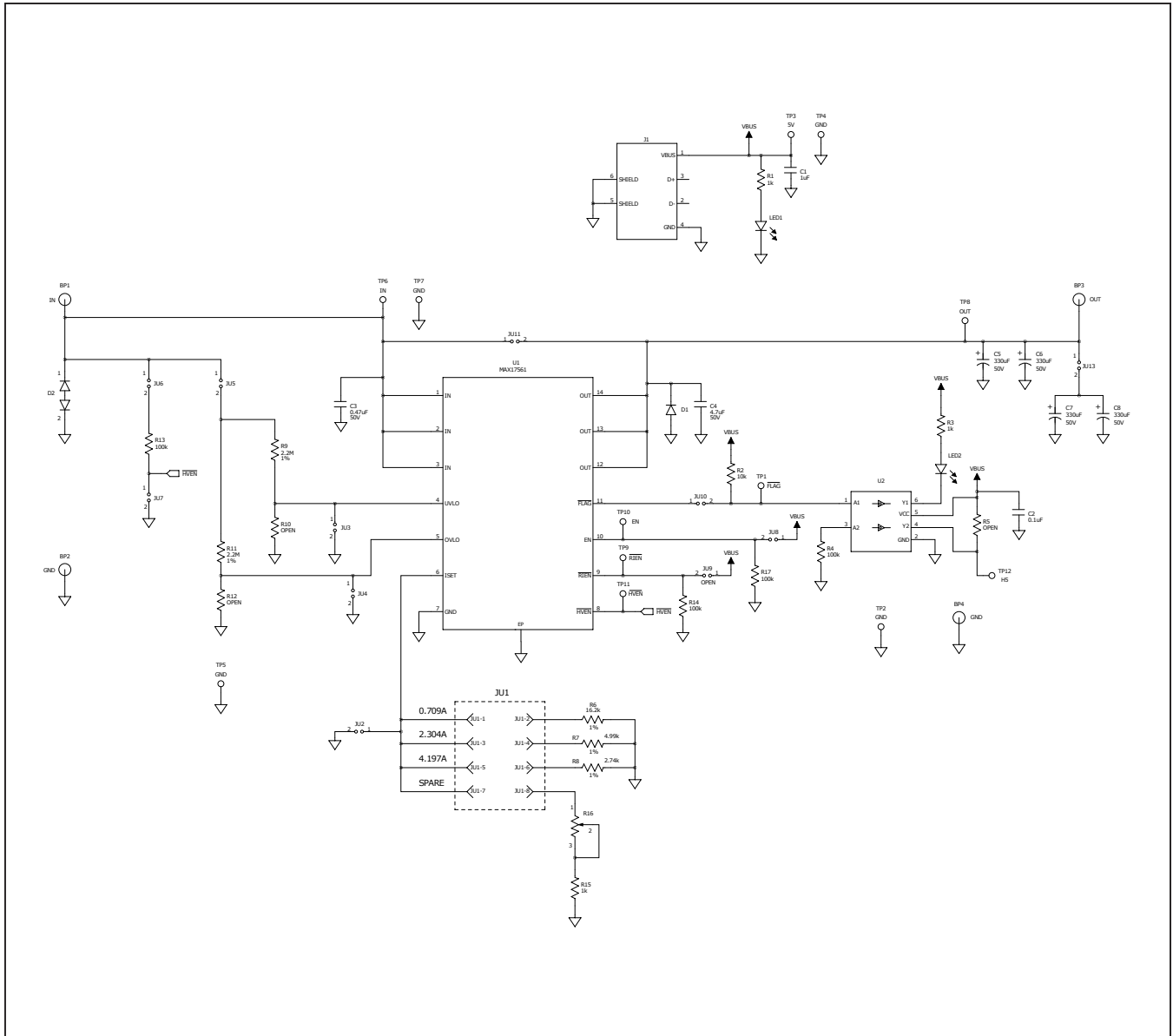

MAX17561 EV Kit PCB Layout Diagrams

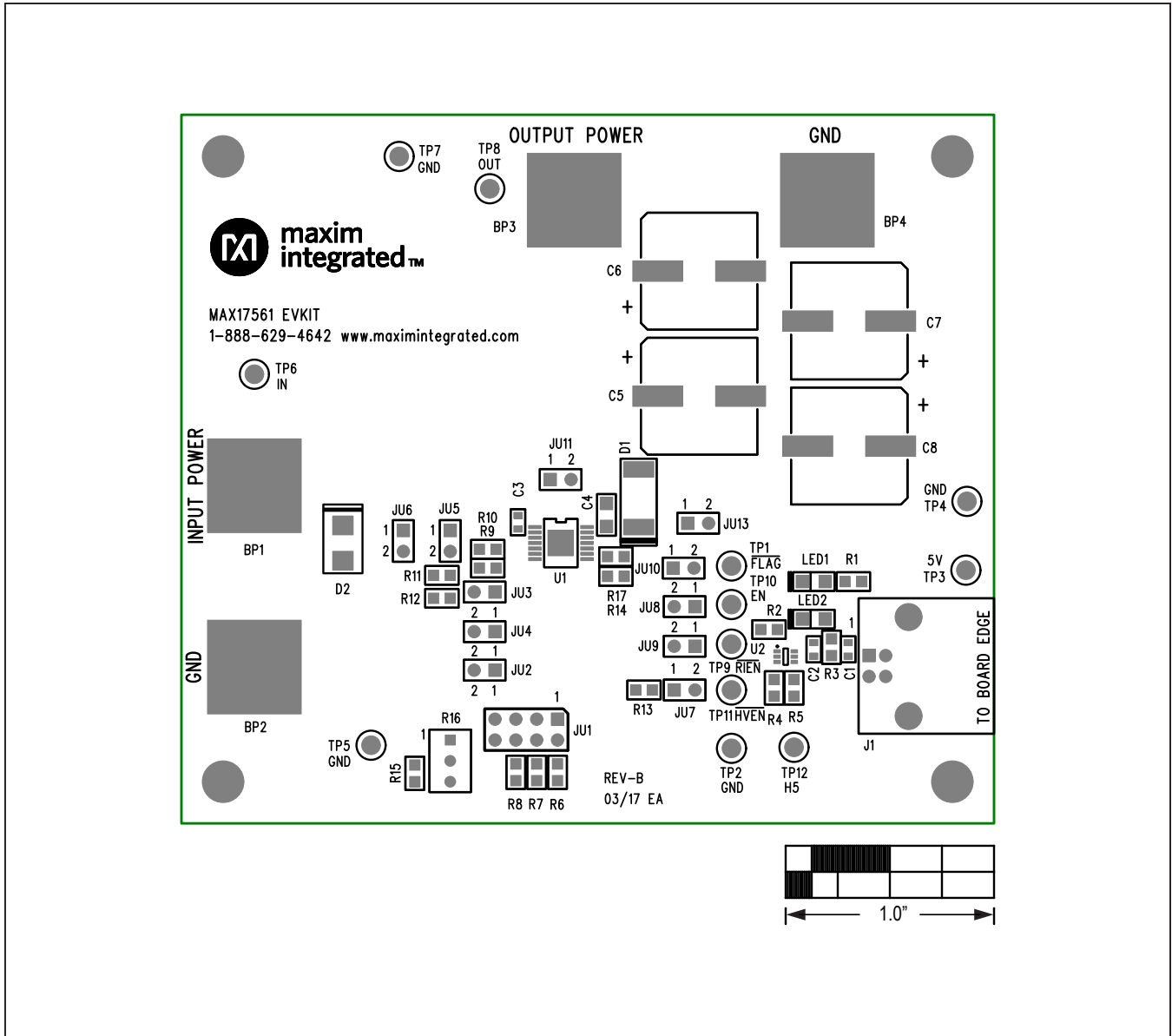

MAX17561 EV Kit Component Placement Guide—Component Side

MAX17561 EV Kit PCB Layout Diagrams (continued)

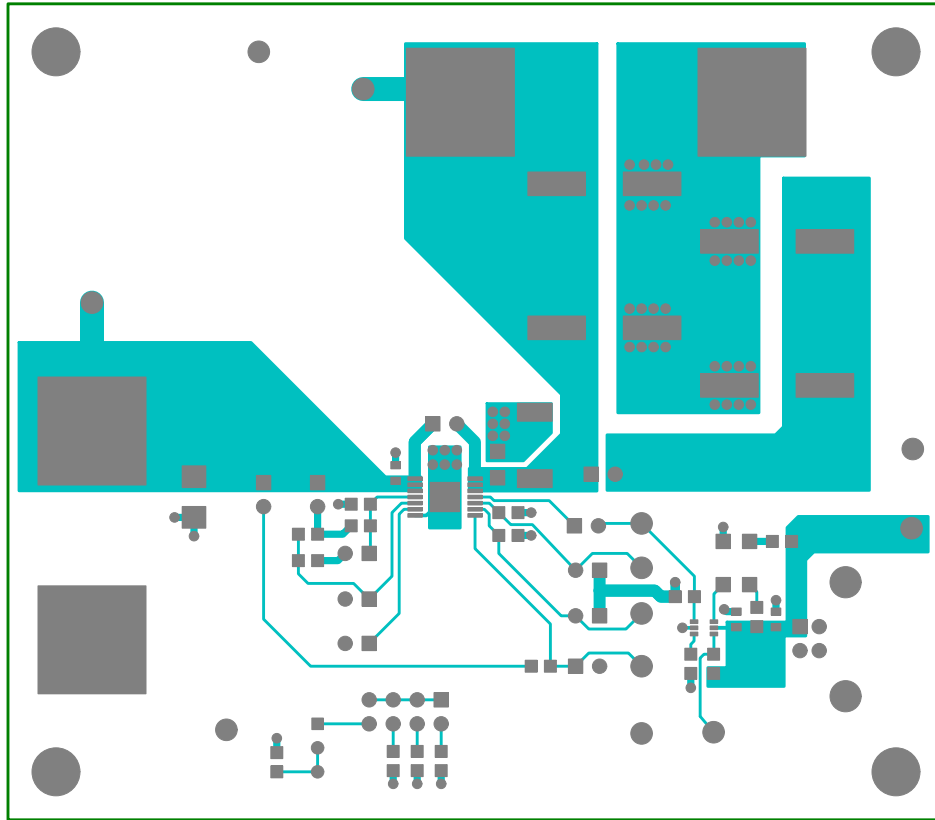

MAX17561 EV Kit PCB Layout—Component Side



MAX17561 EV Kit PCB Layout Diagrams (continued)

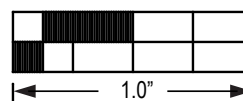
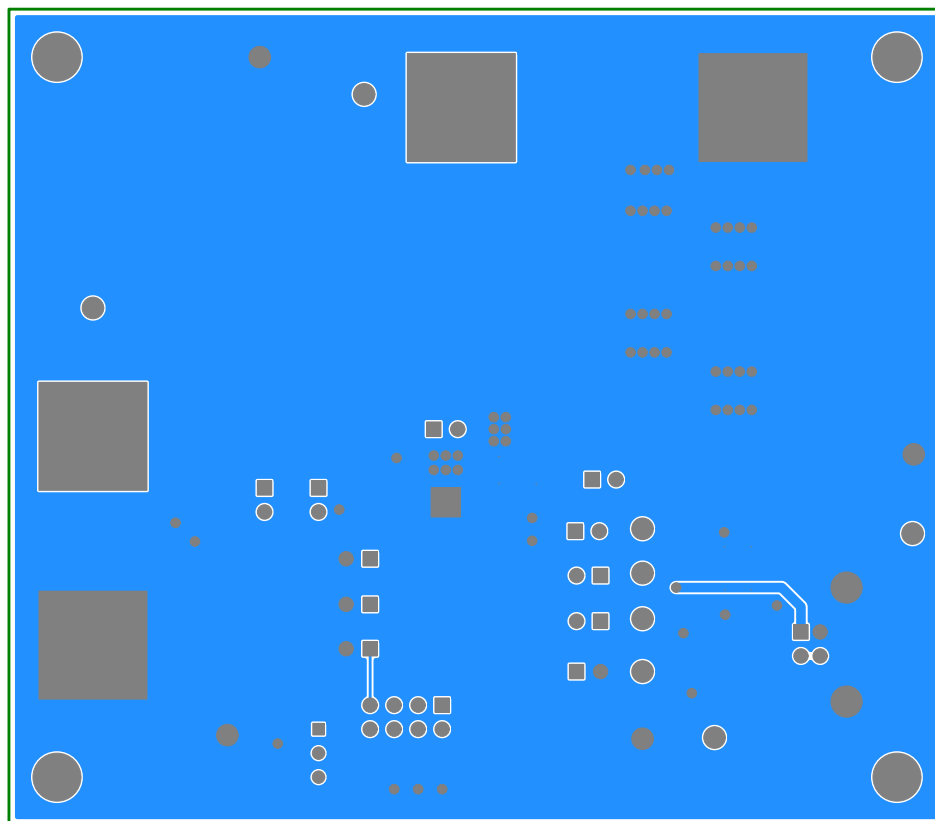

MAX17561 EV Kit PCB Layout—Solder Side

---

## MAX17561 Evaluation Kit

Evaluates: MAX17561, MAX17562, and  
MAX17563—Highly Integrated, Adjustable  
Overcurrent and Overvoltage Protection Solutions

### Revision History

REVISION NUMBER	REVISION DATE	DESCRIPTION	PAGES CHANGED
0	6/17	Initial release	—

For pricing, delivery, and ordering information, please contact Maxim Direct at 1-888-629-4642, or visit Maxim Integrated's website at [www.maximintegrated.com](http://www.maximintegrated.com).

*Maxim Integrated cannot assume responsibility for use of any circuitry other than circuitry entirely embodied in a Maxim Integrated product. No circuit patent licenses are implied. Maxim Integrated reserves the right to change the circuitry and specifications without notice at any time.*

## X-ON Electronics

Largest Supplier of Electrical and Electronic Components

*Click to view similar products for [Power Management IC Development Tools](#) category:*

*Click to view products by [Maxim](#) manufacturer:*

Other Similar products are found below :

[EVB-EP5348UI](#) [MIC23451-AAAYFL EV](#) [MIC5281YMME EV](#) [124352-HMC860LP3E](#) [DA9063-EVAL](#) [ADP122-3.3-EVALZ](#) [ADP130-0.8-EVALZ](#) [ADP130-1.8-EVALZ](#) [ADP1740-1.5-EVALZ](#) [ADP1870-0.3-EVALZ](#) [ADP1874-0.3-EVALZ](#) [ADP199CB-EVALZ](#) [ADP2102-1.25-EVALZ](#) [ADP2102-1.875EVALZ](#) [ADP2102-1.8-EVALZ](#) [ADP2102-2-EVALZ](#) [ADP2102-3-EVALZ](#) [ADP2102-4-EVALZ](#) [AS3606-DB](#) [BQ25010EVM](#) [BQ3055EVM](#) [ISLUSBI2CKIT1Z](#) [LP38512TS-1.8EV](#) [EVAL-ADM1186-1MBZ](#) [EVAL-ADM1186-2MBZ](#) [ADP122UJZ-REDYKIT](#) [ADP166Z-REDYKIT](#) [ADP170-1.8-EVALZ](#) [ADP171-EVALZ](#) [ADP1853-EVALZ](#) [ADP1873-0.3-EVALZ](#) [ADP198CP-EVALZ](#) [ADP2102-1.0-EVALZ](#) [ADP2102-1-EVALZ](#) [ADP2107-1.8-EVALZ](#) [ADP5020CP-EVALZ](#) [CC-ACC-DBMX-51](#) [ATPL230A-EK](#) [MIC23250-S4YMT EV](#) [MIC26603YJL EV](#) [MIC33050-SYHL EV](#) [TPS60100EVM-131](#) [TPS65010EVM-230](#) [TPS71933-28EVM-213](#) [TPS72728YFFEVM-407](#) [TPS79318YEQEVM](#) [UCC28810EVM-002](#) [XILINXPWR-083](#) [LMR22007YMINI-EVM](#) [LP38501ATJ-EV](#)