

MAX17600–MAX17605 Evaluation Kits

Evaluate: MAX17600–MAX17605

General Description

The MAX17600–MAX17605 evaluation kits (EV kits) provide a proven design to evaluate the MAX17600–MAX17605 dual, high-speed, low-side MOSFET drivers that can source/sink up to a 4A peak current. Each EV kit provides four separate designs to evaluate four different IC packages. The EV kits use a 4V to 14V (MAX17600/MAX17601/MAX17602), or a 6V to 14V (MAX17603/MAX17604/MAX17605) input supply.

Installed on the EV kits are the MAX17600–MAX17605 (in 8-pin TDFN, μ MAX[®], and SO packages).

Benefits and Features

- ◆ 4V to 14V Input Range (MAX17600/MAX17601/MAX17602)
- ◆ 6V to 14V Input Range (MAX17603/MAX17604/MAX17605)
- ◆ Sources/Sinks Up to 4A Peak Current
- ◆ Enable Inputs
- ◆ TTL (MAX17600/MAX17601/MAX17602) or High Noise Margin (HNM) (MAX17603/MAX17604/MAX17605) Logic-Level Inputs with Hysteresis for Noise Immunity
- ◆ Evaluates Four Different Packages
- ◆ Proven PCB Layout
- ◆ Fully Assembled and Tested

[Ordering Information/Selector Guide](#) appears at end of data sheet.

Component List

DESIGNATION	QTY	DESCRIPTION
C1, C4, C7, C10	4	2.2 μ F \pm 10%, 25V X7R ceramic capacitors (1206) Murata GRM31MR71E225M
C2, C3, C5, C6, C8, C9, C11, C12	8	0.01 μ F \pm 10%, 50V X7R ceramic capacitors (0603) Murata GRM188R71H103K
C13–C16	4	10 μ F, 25V aluminum electrolytic SMD capacitors (4mm x 5.8mm) Panasonic EEEFK1E100R

DESIGNATION	QTY	DESCRIPTION
JU1–JU8	8	2-pin headers, 0.1in centers
U1	1	See the <i>EV Kit-Specific Component List</i>
U2	1	See the <i>EV Kit-Specific Component List</i>
U3	1	See the <i>EV Kit-Specific Component List</i>
U4	0	Not installed (8 TDFN-EP*)
—	8	Shunts
—	1	PCB: MAX17600/1/2/3/4/5 EVALUATION KIT

*EP = Exposed pad.

μ MAX is a registered trademark of Maxim Integrated Products, Inc.

MAX17600–MAX17605 Evaluation Kits

Evaluate: MAX17600–MAX17605

EV Kit-Specific Component List

PART	REFERENCE DESIGNATOR	DESCRIPTION
MAX17600EVKIT#	U1	MAX17600ATA+ Dual MOSFET driver (8 TDFN-EP*)
	U2	MAX17600ASA+ Dual MOSFET driver (8 SO)
	U3	MAX17600AUA+ Dual MOSFET driver (8 μ MAX-EP*)
MAX17601EVKIT#	U1	MAX17601ATA+ Dual MOSFET driver (8 TDFN-EP*)
	U2	MAX17601ASA+ Dual MOSFET driver (8 SO)
	U3	MAX17601AUA+ Dual MOSFET driver (8 μ MAX-EP*)
MAX17602EVKIT#	U1	MAX17602ATA+ Dual MOSFET driver (8 TDFN-EP*)
	U2	MAX17602ASA+ Dual MOSFET driver (8 SO)
	U3	MAX17602AUA+ Dual MOSFET driver (8 μ MAX-EP*)

PART	REFERENCE DESIGNATOR	DESCRIPTION
MAX17603EVKIT#	U1	MAX17603ATA+ Dual MOSFET driver (8 TDFN-EP*)
	U2	MAX17603ASA+ Dual MOSFET driver (8 SO)
	U3	MAX17603AUA+ Dual MOSFET driver (8 μ MAX-EP*)
MAX17604EVKIT#	U1	MAX17604ATA+ Dual MOSFET driver (8 TDFN-EP*)
	U2	MAX17604ASA+ Dual MOSFET driver (8 SO)
	U3	MAX17604AUA+ Dual MOSFET driver (8 μ MAX-EP*)
MAX17605EVKIT#	U1	MAX17605ATA+ Dual MOSFET driver (8 TDFN-EP*)
	U2	MAX17605ASA+ Dual MOSFET driver (8 SO)
	U3	MAX17605AUA+ Dual MOSFET driver (8 μ MAX-EP*)

*EP = Exposed pad.

Component Suppliers

SUPPLIER	PHONE	WEBSITE
Murata Electronics North America, Inc.	770-436-1300	www.murata-northamerica.com
Panasonic Corp.	800-344-2112	www.panasonic.com

Note: Indicate that you are using the MAX17600–MAX17605 when contacting these component suppliers.

MAX17600–MAX17605 Evaluation Kits

Evaluate: MAX17600–MAX17605

Quick Start

Required Equipment

- MAX17600–MAX17605 EV kit
- 4V to 14V DC power supply

Procedure

The EV kits are fully assembled and tested. Follow the steps below to verify U1 board operation. **Caution: Do not turn on the power supply until all connections are completed.**

- 1) Verify that all jumpers are in their default positions, as shown in Table 1.
- 2) Connect the positive terminal of the power supply to the VDD1 PCB pad and the negative terminal to the nearest GND PCB pad on the EV kit.
- 3) Set the VDD1 power supply to 14V and enable its output.
- 4) Drive INA1 high and verify that the OUTA1 polarity is according to Table 2.
- 5) Drive INB1 high and verify that the OUTB1 polarity is according to Table 2.
- 6) Drive INA1 low and verify that the OUTA1 polarity is according to Table 2.
- 7) Drive INB1 low and verify that the OUTB1 polarity is according to Table 2.
- 8) Repeat accordingly for the other circuits.

Table 1. Jumper Descriptions (JU1–JU8)

JUMPER	SHUNT POSITION	DESCRIPTION
JU1	1-2	Disables channel A for the TDFN-EP (3mm x 3mm) package
	Open*	Enables channel A for the TDFN-EP (3mm x 3mm) package
JU2	1-2	Disables channel B for the TDFN-EP (3mm x 3mm) package
	Open*	Enables channel B for the TDFN-EP (3mm x 3mm) package
JU3	1-2	Disables channel A for the SO (3.9mm x 4.9mm) package
	Open*	Enables channel A for the SO (3.9mm x 4.9mm) package
JU4	1-2	Disables channel B for the SO (3.9mm x 4.9mm) package
	Open*	Enables channel B for the SO (3.9mm x 4.9mm) package
JU5	1-2	Disables channel A for the μMAX-EP (3mm x 3mm) package
	Open*	Enables channel A for the μMAX-EP (3mm x 3mm) package
JU6	1-2	Disables channel B for the μMAX-EP (3mm x 3mm) package
	Open*	Enables channel B for the μMAX-EP (3mm x 3mm) package
JU7	1-2	Disables channel A for the TDFN-EP (2mm x 3mm) package
	Open*	Enables channel A for the TDFN-EP (2mm x 3mm) package
JU8	1-2	Disables channel B for the TDFN-EP (2mm x 3mm) package
	Open*	Enables channel B for the TDFN-EP (2mm x 3mm) package

*Default position.

Table 2. OUTA/OUTB Polarity vs. INA/INB Polarity

PART	OUTA POLARITY	OUTB POLARITY
MAX17600EVKIT#	Inverting	Inverting
MAX17601EVKIT#	Noninverting	Noninverting
MAX17602EVKIT#	Inverting	Noninverting
MAX17603EVKIT#	Inverting	Inverting
MAX17604EVKIT#	Noninverting	Noninverting
MAX17605EVKIT#	Inverting	Noninverting

MAX17600–MAX17605 Evaluation Kits

Evaluate: MAX17600–MAX17605

Detailed Description of Hardware

The MAX17600–MAX17605 EV kits operate on a 4V to 14V (MAX17600/MAX17601/MAX17602) or a 6V to 14V (MAX17603/MAX17604/MAX17605) wide-input voltage range and sources/sinks 4A peak current.

Enable (EN_ _)

Each EV kit has four separate sets of enables to evaluate each package:

- 1) ENA1/ENB1 enables/disables the TDFN-EP package
- 2) ENA2/ENB2 enables/disables the SO package
- 3) ENA3/ENB3 enables/disables the μ MAX-EP package
- 4) ENA4/ENB4 enables/disables the TDFN-EP package

Input (IN_ _)

Each EV kit has four separate sets of inputs to evaluate each package:

- 1) INA1/INB1 inputs control the output state for the TDFN-EP package
- 2) INA2/INB2 inputs control the output state for the SO package

3) INA3/INB3 inputs control the output state for the μ MAX-EP package

4) INA4/INB4 inputs control the output state for the TDFN-EP package

Power Supply Input (VDD_)

Each EV kit has four separate VDD inputs to evaluate each package:

- 1) VDD1 supplies power to the TDFN-EP package
- 2) VDD2 supplies power to the SO package
- 3) VDD3 supplies power to the μ MAX-EP package
- 4) VDD4 supplies power to the TDFN-EP package

Ground (GND)

Each EV kit has four circuits to evaluate each package. Each circuit has its own ground plane and each GND is not connected to the GND of the nearby circuit.

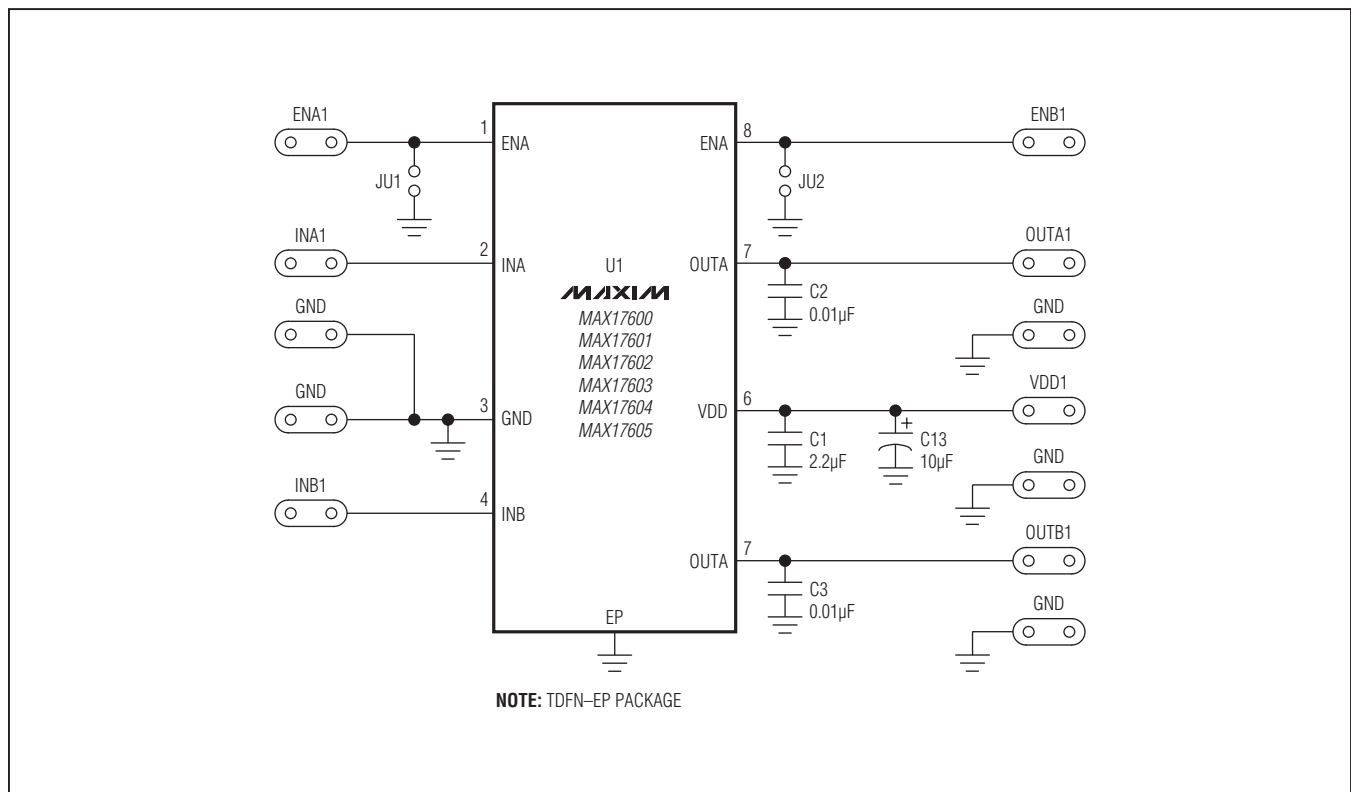

Figure 1a. MAX17600–MAX17605 EV Kit Schematic (U1)

MAX17600–MAX17605 Evaluation Kits

Evaluate: MAX17600–MAX17605

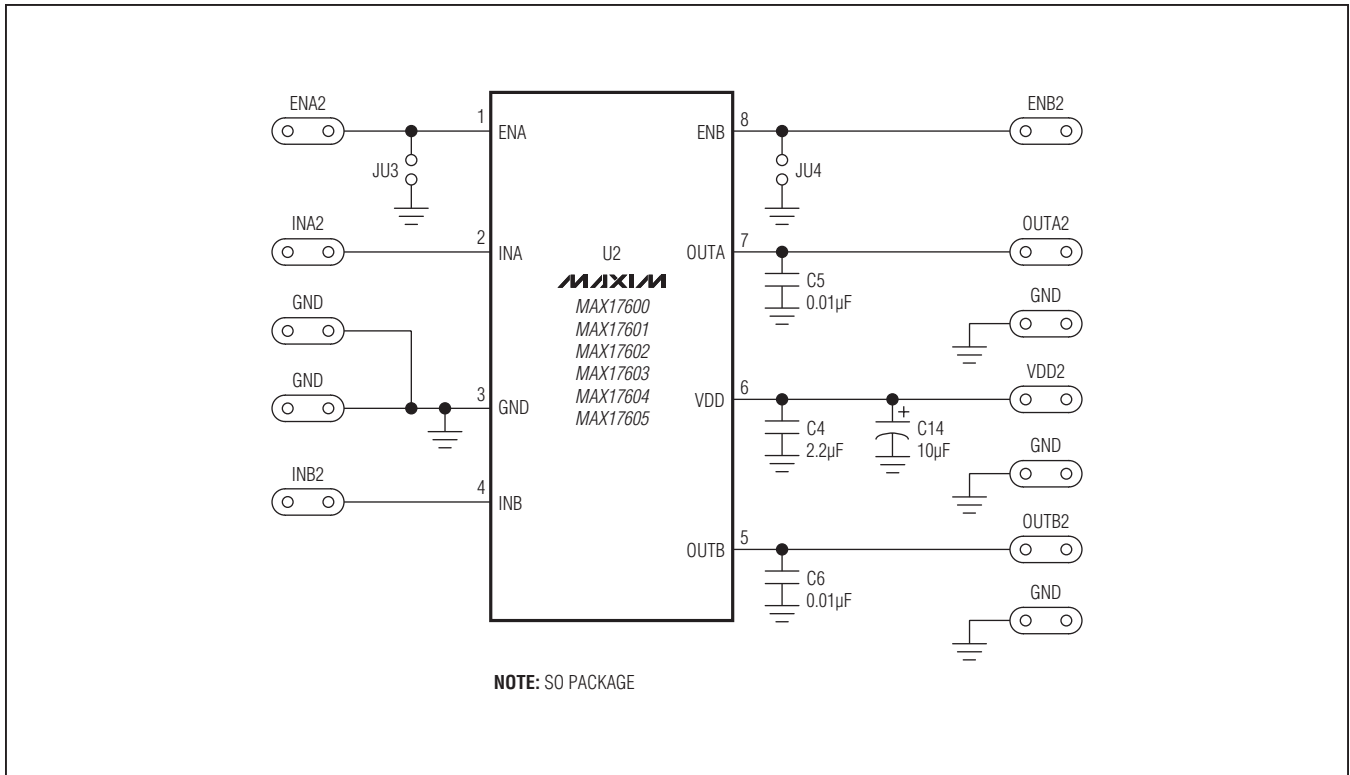

Figure 1b. MAX17600–MAX17605 EV Kit Schematic (U2)

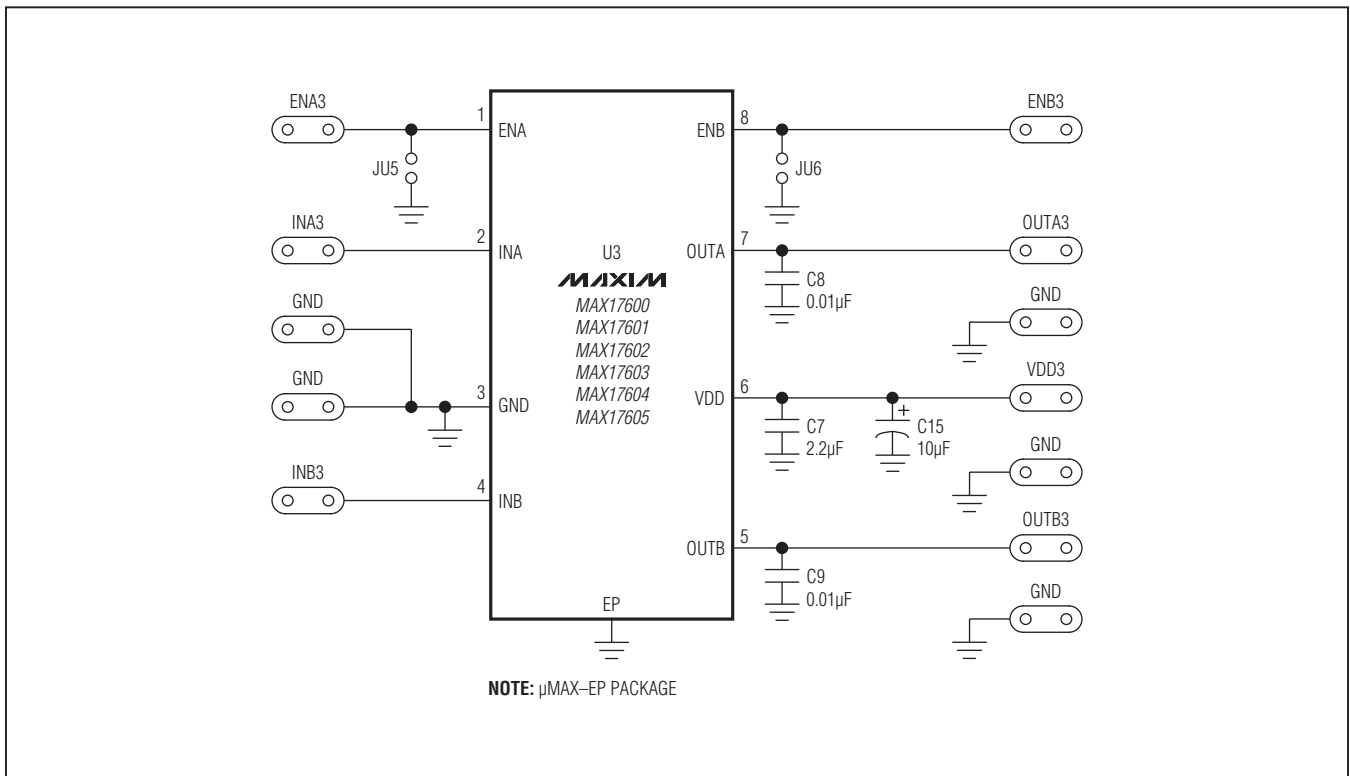

Figure 1c. MAX17600–MAX17605 EV Kit Schematic (U3)

MAX17600–MAX17605 Evaluation Kits

Evaluate: MAX17600–MAX17605

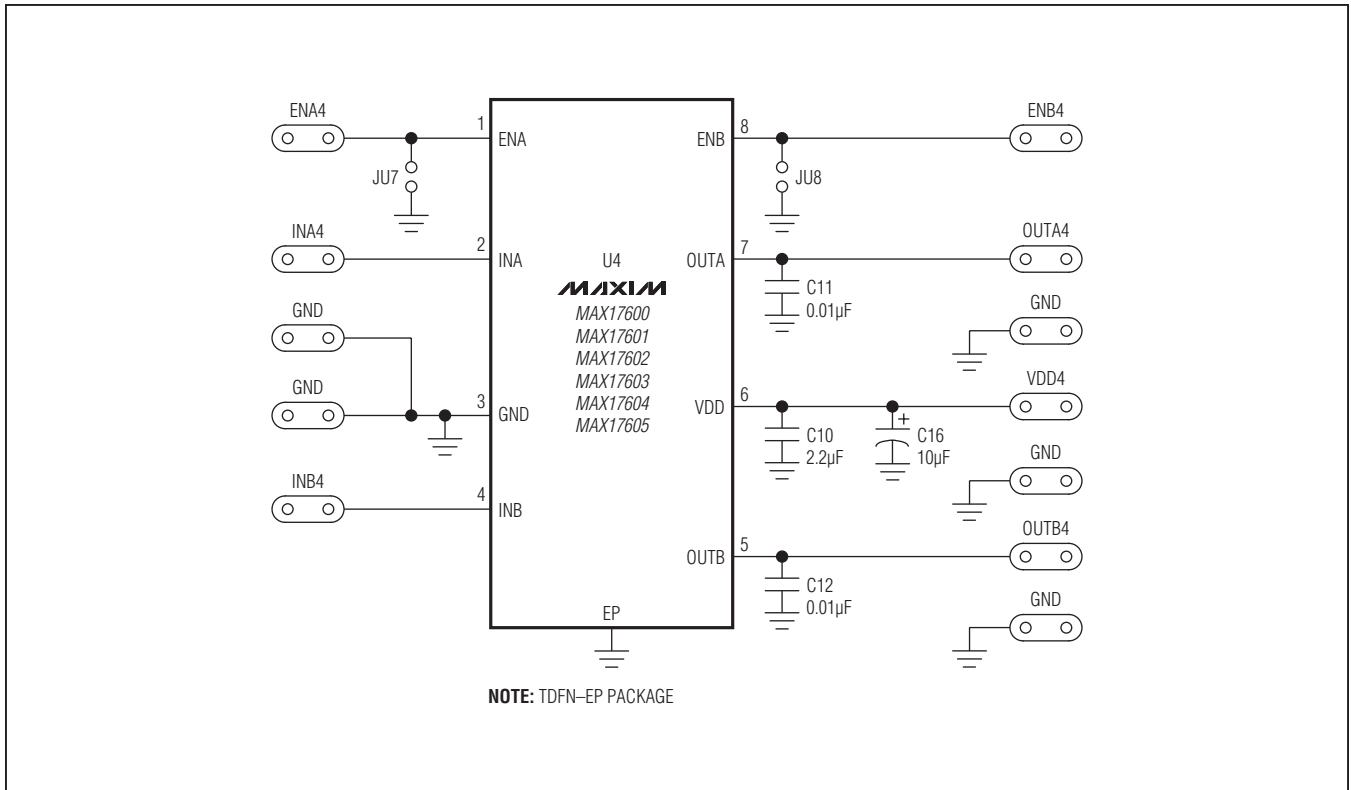

Figure 1d. MAX17600–MAX17605 EV Kit Schematic (U4)

MAX17600–MAX17605 Evaluation Kits

Evaluate: MAX17600–MAX17605

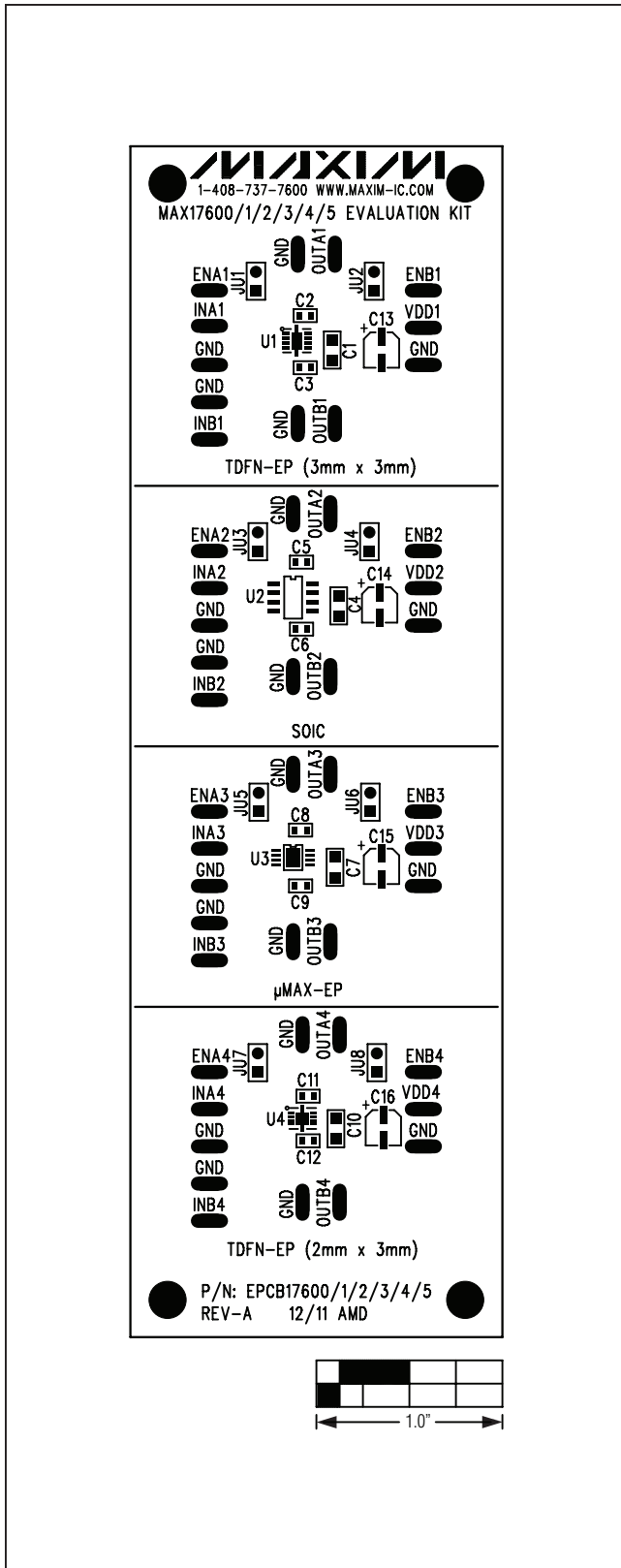

Figure 2. MAX17600–MAX17605 EV Kit Component Placement Guide—Component Side

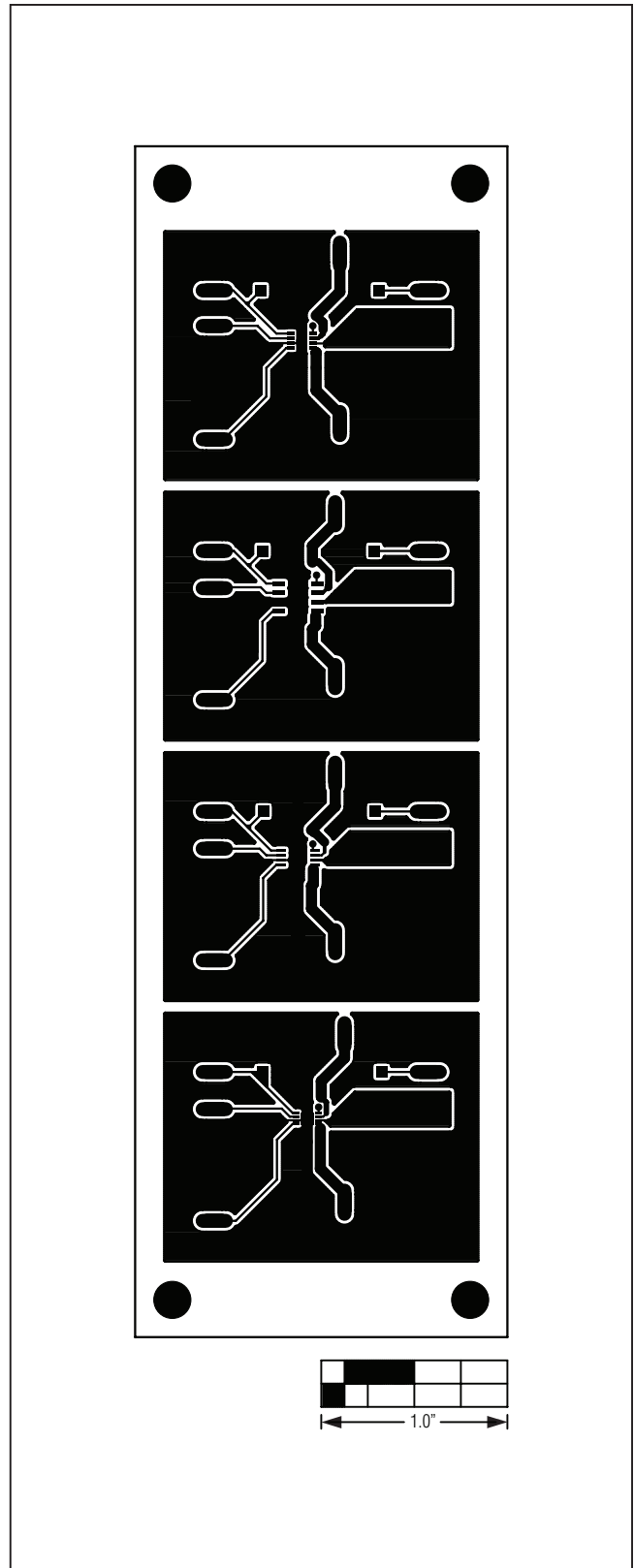

Figure 3. MAX17600–MAX17605 EV Kit PCB Layout—Component Side

MAX17600–MAX17605 Evaluation Kits

Evaluate: MAX17600–MAX17605

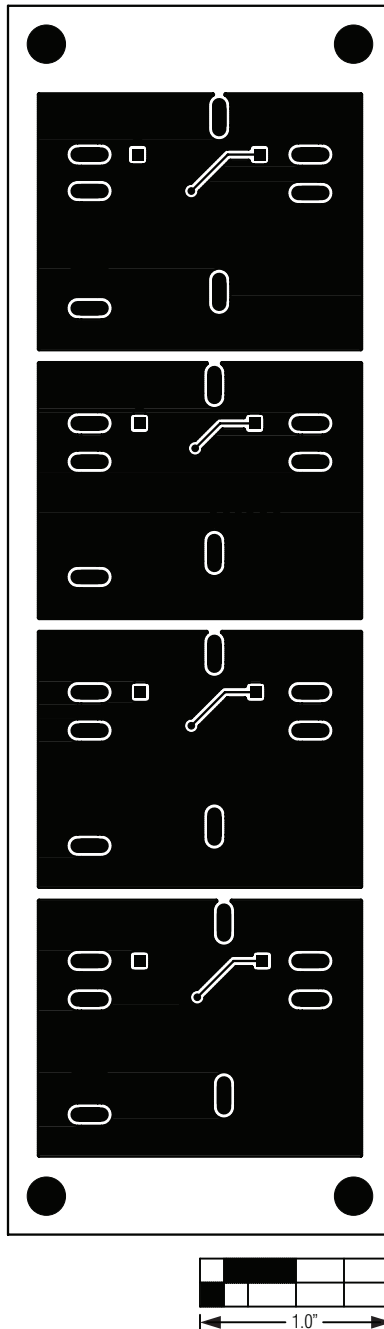

Figure 4. MAX17600–MAX17605 EV Kit PCB Layout—Solder Side

MAX17600–MAX17605 Evaluation Kits

Evaluate: MAX17600–MAX17605

Ordering Information/Selector Guide

PART	TYPE	INPUT LOGIC TYPE	OUTA POLARITY	OUTB POLARITY
MAX17600EVKIT#*	EV Kit	TTL	Inverting	Inverting
MAX17601EVKIT#	EV Kit	TTL	Noninverting	Noninverting
MAX17602EVKIT#	EV Kit	TTL	Inverting	Noninverting
MAX17603EVKIT#	EV Kit	HNM	Inverting	Inverting
MAX17604EVKIT#	EV Kit	HNM	Noninverting	Noninverting
MAX17605EVKIT#	EV Kit	HNM	Inverting	Noninverting

#Denotes RoHS compliant.

*Future product—contact factory for availability.

MAX17600–MAX17605 Evaluation Kits

Evaluate: MAX17600–MAX17605

Revision History

REVISION NUMBER	REVISION DATE	DESCRIPTION	PAGES CHANGED
0	6/12	Initial release	—

Maxim cannot assume responsibility for use of any circuitry other than circuitry entirely embodied in a Maxim product. No circuit patent licenses are implied. Maxim reserves the right to change the circuitry and specifications without notice at any time.

Maxim Integrated Products, Inc. 160 Rio Robles, San Jose, CA 95134 USA 1-408-601-1000 _____ 10

X-ON Electronics

Largest Supplier of Electrical and Electronic Components

Click to view similar products for [Power Management IC Development Tools](#) category:

Click to view products by [Maxim](#) manufacturer:

Other Similar products are found below :

[EVB-EP5348UI](#) [MIC23451-AAAYFL EV](#) [MIC5281YMME EV](#) [124352-HMC860LP3E](#) [DA9063-EVAL](#) [ADP122-3.3-EVALZ](#) [ADP130-0.8-EVALZ](#) [ADP130-1.8-EVALZ](#) [ADP1740-1.5-EVALZ](#) [ADP1870-0.3-EVALZ](#) [ADP1874-0.3-EVALZ](#) [ADP199CB-EVALZ](#) [ADP2102-1.25-EVALZ](#) [ADP2102-1.875EVALZ](#) [ADP2102-1.8-EVALZ](#) [ADP2102-2-EVALZ](#) [ADP2102-3-EVALZ](#) [ADP2102-4-EVALZ](#) [AS3606-DB](#) [BQ25010EVM](#) [BQ3055EVM](#) [ISLUSBI2CKIT1Z](#) [LP38512TS-1.8EV](#) [EVAL-ADM1186-1MBZ](#) [EVAL-ADM1186-2MBZ](#) [ADP122UJZ-REDYKIT](#) [ADP166Z-REDYKIT](#) [ADP170-1.8-EVALZ](#) [ADP171-EVALZ](#) [ADP1853-EVALZ](#) [ADP1873-0.3-EVALZ](#) [ADP198CP-EVALZ](#) [ADP2102-1.0-EVALZ](#) [ADP2102-1-EVALZ](#) [ADP2107-1.8-EVALZ](#) [ADP5020CP-EVALZ](#) [CC-ACC-DBMX-51](#) [ATPL230A-EK](#) [MIC23250-S4YMT EV](#) [MIC26603YJL EV](#) [MIC33050-SYHL EV](#) [TPS60100EVM-131](#) [TPS65010EVM-230](#) [TPS71933-28EVM-213](#) [TPS72728YFFEVM-407](#) [TPS79318YEQEVM](#) [UCC28810EVM-002](#) [XILINXPWR-083](#) [LMR22007YMINI-EVM](#) [LP38501ATJ-EV](#)