

# MAX17623/MAX17624 Evaluation Kits

# Evaluates: MAX17623/MAX17624 Converters in Application

## General Description

The MAX17623/MAX17624 evaluation kits (EV kits) provide a proven design to evaluate the performance of the MAX17623/MAX17624 converters. Each of these devices operates over an input range from 2.9V to 5.5V and delivers up to 1A output current. The devices are configured to demonstrate optimum performance and component sizes in the EV kits.

The MAX17623 converter delivers up to 1A at a switching frequency of 2MHz. The converter is configured for a 1.5V output over a 2.9V to 5.5V input range.

The MAX17624 converter delivers up to 1A at a switching frequency of 4MHz. The converter is configured for a 3.3V output over a 3.6V to 5.5V input range.

The EV kits feature provisions for selecting Mode of operation (PWM/PFM), enabling or disabling the output and PGOOD signal. The *MAX17623/MAX17624 converter data sheet* provides a complete description of the parts, that should be read in conjunction with this data sheet prior to operating the EV kits.

## Features

- 2.9V to 5.5V Input-Voltage Range
- MAX17623 Offers High 92.2% Efficiency ( $V_{IN} = 3.3V$ ,  $V_{OUT} = 1.5V$ ,  $I_{OUT} = 300\text{ mA}$ )
- MAX17624 Offers High 94.5% Efficiency ( $V_{IN} = 5V$ ,  $V_{OUT} = 3.3V$ ,  $I_{OUT} = 500\text{ mA}$ )
- Selectable PWM and PFM Modes of Operation
- Internal 1ms Soft-Start Time
- PGOOD Output with Pullup Resistor to Respective Input Voltages
- Low-Profile, Surface-Mount Components
- Proven PCB Layout
- Fully Assembled and Tested

[Ordering Information](#) at end of data sheet.

## EV Kits Top View

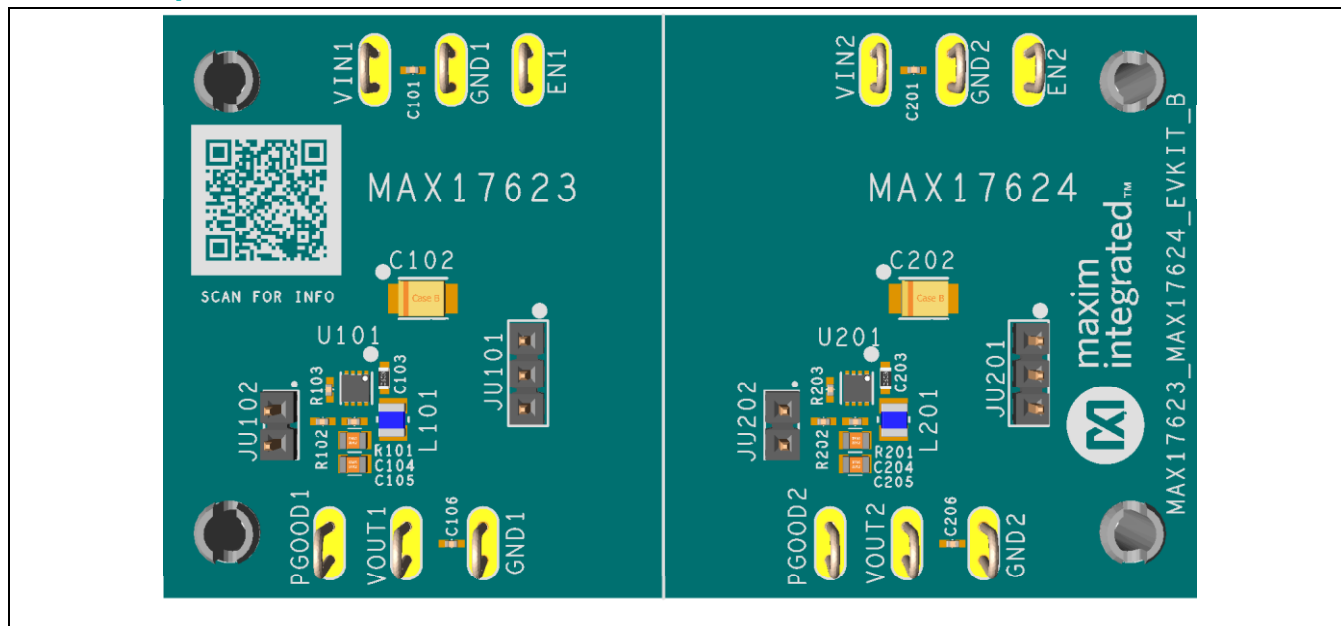

## Quick Start

### Configuration Diagram

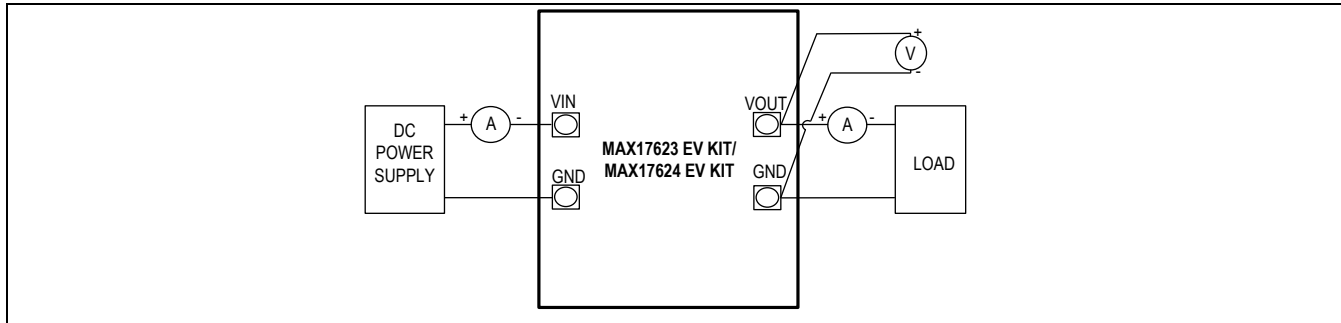

Figure 1. MAX17623/MAX17624 EV Kits Setup Diagram

### Required Equipment

- One 2.9V to 5.5V DC, 1A power supply
- Load resistors capable of sinking up to 1A at 1.5V and 3.3V
- Digital multimeter (DMM)

### Procedure

A typical bench setup for MAX17623/MAX17624 EV Kits is shown in [Figure 1](#).

The EV kits are fully assembled and tested. Follow the steps below to verify and test individual converters operation.

**Caution: Do not turn on power supply until all connections are completed.**

1. Disable the power supply and set the input power supply at a voltage between 2.9V and 5.5V for MAX17623, or between 3.6V to 5.5V for MAX17624.
2. Connect the positive terminal and negative terminal of the power supply to the VIN pad and its adjacent GND pad of the converter under evaluation, respectively.
3. Connect a maximum 1A resistive load across the VOUT pad and its nearest GND pad of the corresponding converter.
4. Verify that shunts are installed in default position on jumpers (JU101 and JU201) (see [Table 1](#) for details).
5. Select the shunt position on jumpers (JU102, JU202) according to the required mode of operation (see [Table 2](#) for details).
6. Connect the digital multimeter (in voltage measurement mode) across the VOUT and its respective GND pad.
7. Turn on the input power supply.
8. Verify that the digital multimeter displays 1.5V for MAX17623, and 3.3V for MAX17624 output terminal voltages, respectively with respect to GND.

## Detailed Description

The MAX17623/MAX17624 EV kits are designed to demonstrate the salient features of the MAX17623/MAX17624 power converters. The EV kits consist of typical application circuits of two different converters. Each of these circuits are electrically isolated from each other and hosted on the same PCB. Each of the converters can be evaluated by powering them from their respective input terminals. Individual converter settings can be adjusted to evaluate their performance under different operating conditions.

### MODE Selection

The MAX17623/MAX17624 supports PWM and PFM modes of operation. In the EV kits, leave the jumpers (JU102, JU202) open for operating the converters in PFM mode at light-load. Install shunts to configure the converters in PWM mode. See [Table 2](#) for jumpers (JU102 and JU202) settings.

### Adjusting Output Voltage

The MAX17623 supports a 0.8V to 1.5V adjustable output voltage and the MAX17623 EV kit output voltage is preset to 1.5V.

The MAX17624 supports a 1.5V to 3.3V adjustable output voltage and the MAX17624 EV kit output voltage is preset to 3.3V.

Output voltage can be programmed using the feedback resistive-divider from VOUT to FB to GND (R101 and R102 for MAX17623, and R201 and R202 for MAX17624). For programming the output to a different voltage, use values calculated based on the guidelines given in the *MAX17623/MAX17624 converter data sheet*.

### Output Capacitor Selection

X7R ceramic output capacitors are preferred due to their stability over temperature in industrial applications. The required output capacitors (C104 and C204) are selected based on the values given in the *MAX17623/MAX17624 converter data sheet* as 22 $\mu$ F/6.3V and 10 $\mu$ F/6.3V, respectively.

### Input Capacitor Selection

The input capacitors (C103 and C203) serve to reduce current peaks drawn from the input power supply and reduce switching frequency ripple at the input. The input capacitance must be greater than or equal to the value calculated by the equations given in the *MAX17623/MAX17624 converter data sheet*. Input capacitors (C103 and C203) are chosen to be 2.2 $\mu$ F/10V.

### Hot Plug-In and Long cables

The MAX17623/MAX17624 EV kit PCB provides optional Tantalum capacitors (C102 and C202, 47 $\mu$ F/8V) to dampen input-voltage peaks and oscillations that can arise during hot-plug-in and/or due to long input cables. These capacitors limit the peak voltage at the input of the device when the EV kits are powered directly from a precharged capacitive source or an industrial backplane PCB. Long input cables, between input power source and the EV kits circuit can cause input-voltage oscillations due to the inductance of the cables. The equivalent series resistance (ESR) of the Tantalum capacitor helps damp out the oscillations caused by long input cables. Further, capacitors C101, C106, C201, C206 (0.1 $\mu$ F/100V) placed near the edge of the board near the input and output terminals, help in attenuating high frequency noise.

**Table 1. EN Jumper Description (JU101, JU201)**

SHUNT POSITION	EN PIN	OUTPUT
1–2*	Connected to $V_{IN}$	Enabled
2–3	Connected to GND	Disabled

\*Default Position

**Table 2. MODE Jumper Description (JU102, JU202)**

SHUNT	MODE PIN	MODE
1–2	Connected to GND	Operates in PWM Mode in all load conditions
Not Installed*	Unconnected	Operates in PFM Mode in light-load conditions

\*Default Position

## Ordering Information

PART NUMBER	TYPE
MAX17623EVKIT#	EV Kit
MAX17624EVKIT#	EV Kit

# Denotes RoHS compliance.

## Component Suppliers

SUPPLIER	WEBSITE
Murata Americas	<a href="http://www.murata.com">www.murata.com</a>
Vishay	<a href="http://www.vishay.com">www.vishay.com</a>
Panasonic	<a href="http://www.panasonic.com">www.panasonic.com</a>
TDK Corp.	<a href="http://www.tdk.com">www.tdk.com</a>
Kemet	<a href="http://www.kemet.com">www.kemet.com</a>

MAX17623/MAX17624 EV Kits Performance

( $V_{IN} = 3.3V$  for MAX17623,  $V_{IN} = 5V$  for MAX17624,  $T_A = 25^\circ C$ , unless otherwise noted.)

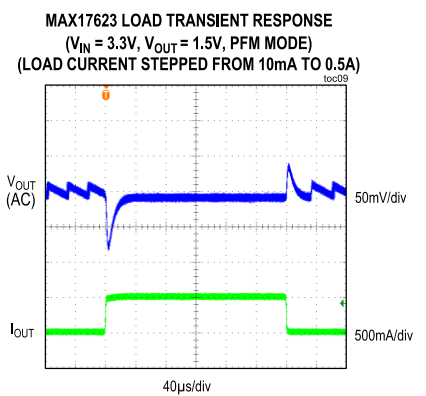
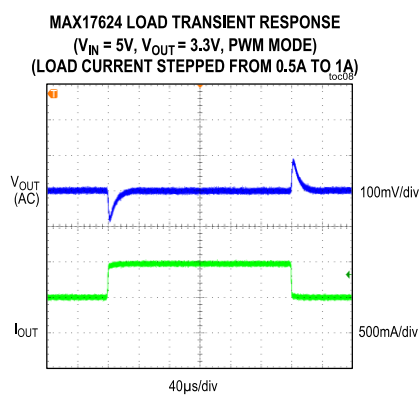
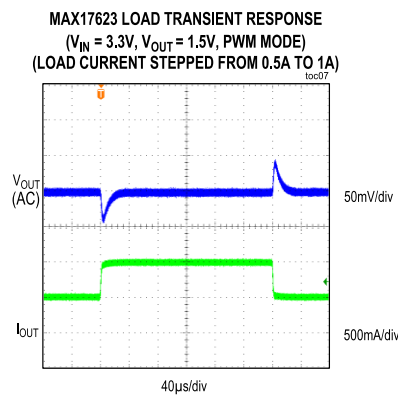
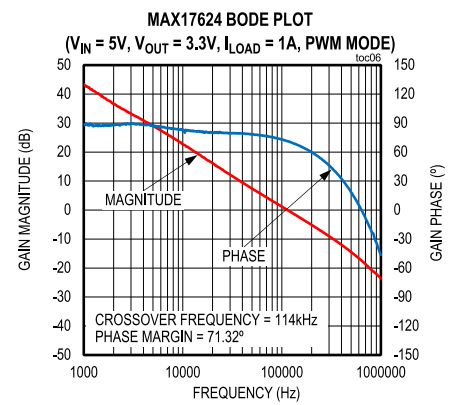
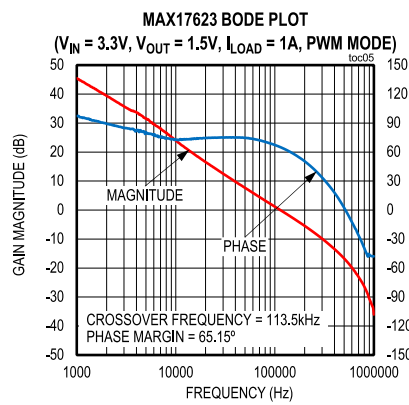
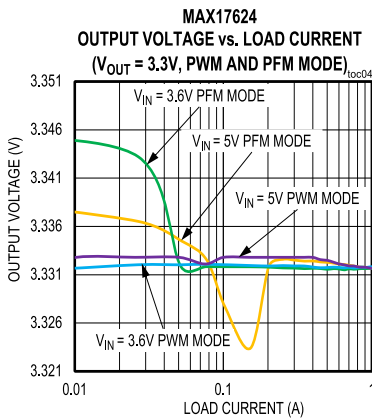
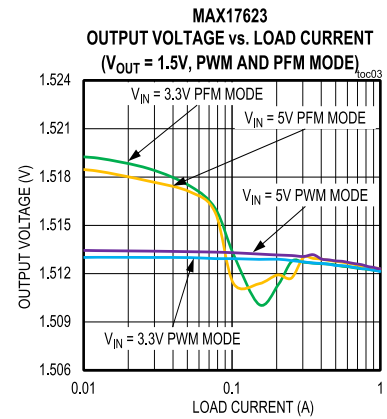
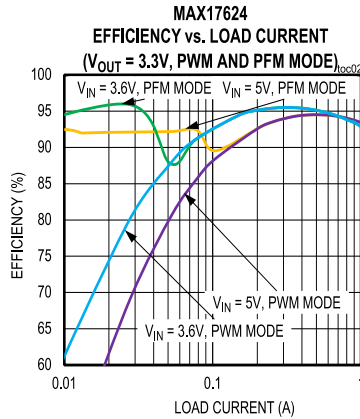
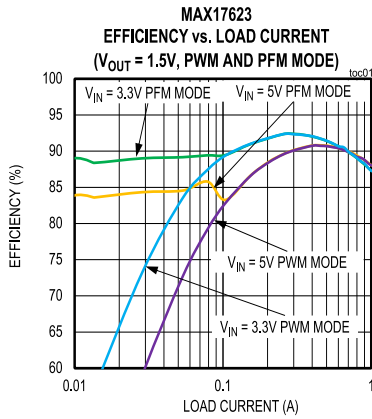

**MAX17623/MAX17624 EV Kits Performance**

( $V_{IN} = 3.3V$  for MAX17623,  $V_{IN} = 5V$  for MAX17624,  $T_A = 25^\circ C$ , unless otherwise noted.)

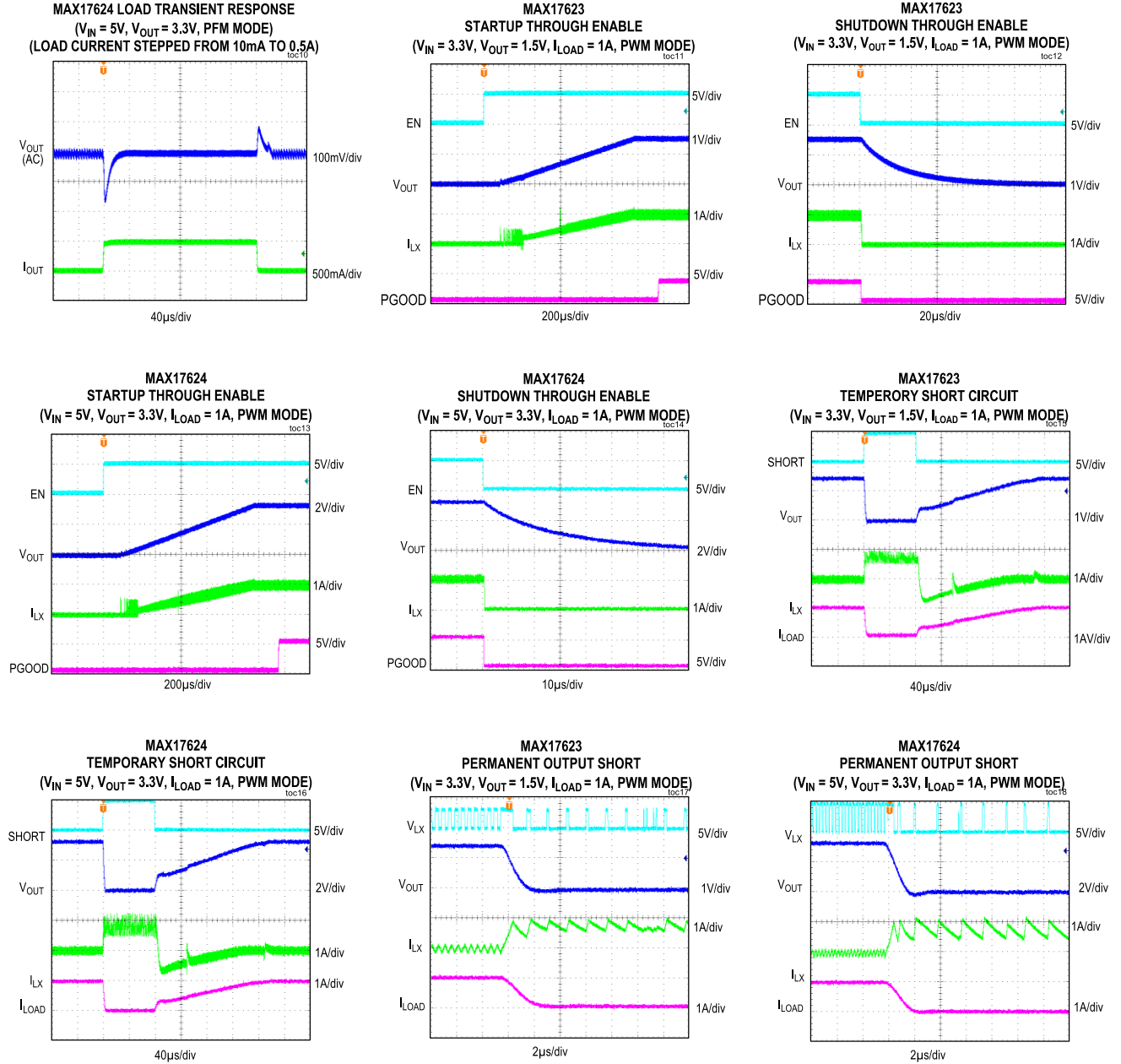

### MAX17623/MAX17624 EV Kits Performance

( $V_{IN} = 3.3V$  for MAX17623,  $V_{IN} = 5V$  for MAX17624,  $T_A = 25^\circ C$ , unless otherwise noted.)

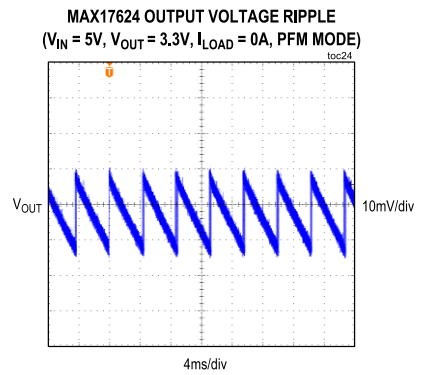
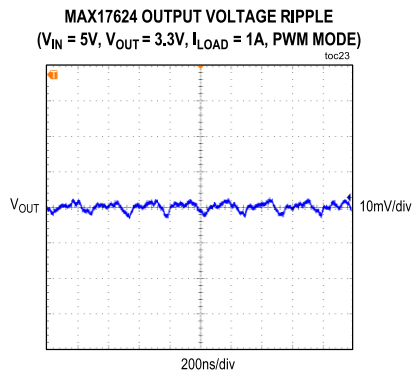
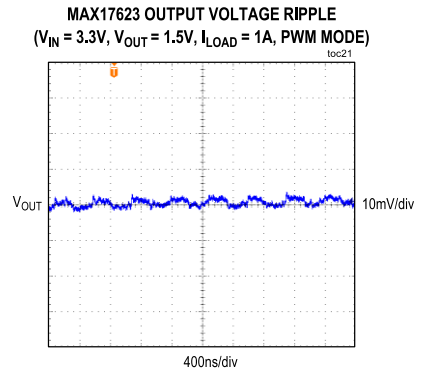
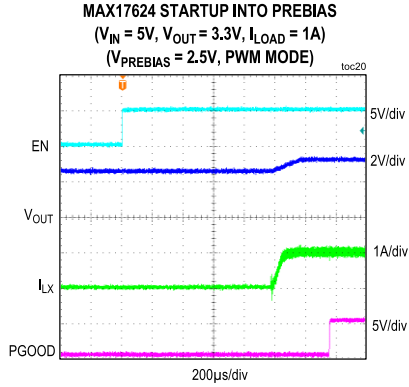
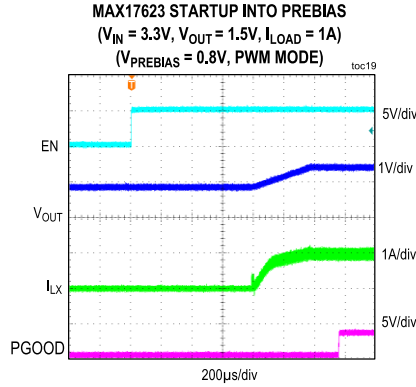

**MAX17623/MAX17624 EV Kits Bill of Materials**

ITEM	QTY	DESIGNATOR	DESCRIPTION	MANUFACTURER PART NUMBER
1	4	C101, C106, C201, C206	0.1 $\mu$ F $\pm$ 10%, 10V, X7R, ceramic capacitor (0402)	TDK C1005X5R1A104050BA
2	2	C102, C202	47 $\mu$ F $\pm$ 20%, 8V, Tantalum capacitor (3528)	Kemet T520B476M008ATE035
3	2	C103, C203	2.2 $\mu$ F $\pm$ 10%, 10V, X7R, ceramic capacitor (0603)	Murata GRM188R71A225KE15
4	1	C104	22 $\mu$ F $\pm$ 20%, 6.3V, X7R, ceramic capacitor (0805)	Murata GRM21BZ70J226ME44
5	1	C204	10 $\mu$ F $\pm$ 10%, 6.3V, X7R, ceramic capacitor (0805)	Murata GRM21BR70J106K
6	1	L101	1.5 $\mu$ H $\pm$ 20%, 2.7A, Inductor (2520)	Murata DFE252012F-1R5M
7	1	L201	1 $\mu$ H $\pm$ 20%, 3.8A, Inductor (2520)	Murata DFE252012F-1R0M
8	1	R101	33.2k $\Omega$ $\pm$ 1% resistor (0402)	Vishay CRCW04023322FK
9	1	R201	118k $\Omega$ $\pm$ 1% resistor (0402)	Vishay CRCW0402118KFK
10	2	R102, R202	37.4k $\Omega$ $\pm$ 1% resistor (0402)	Vishay CRCW040237K4FK
11	2	R103, R203	100k $\Omega$ $\pm$ 1% resistor (0402)	Panasonic ERJ-2RKF1003X
12	1	U101	MAX17623 TDFN8-EP	MAX17623ATA+
13	1	U201	MAX17624 TDFN8-EP	MAX17624ATA+



MAX17623/MAX17624 EV Kits Schematic Diagram

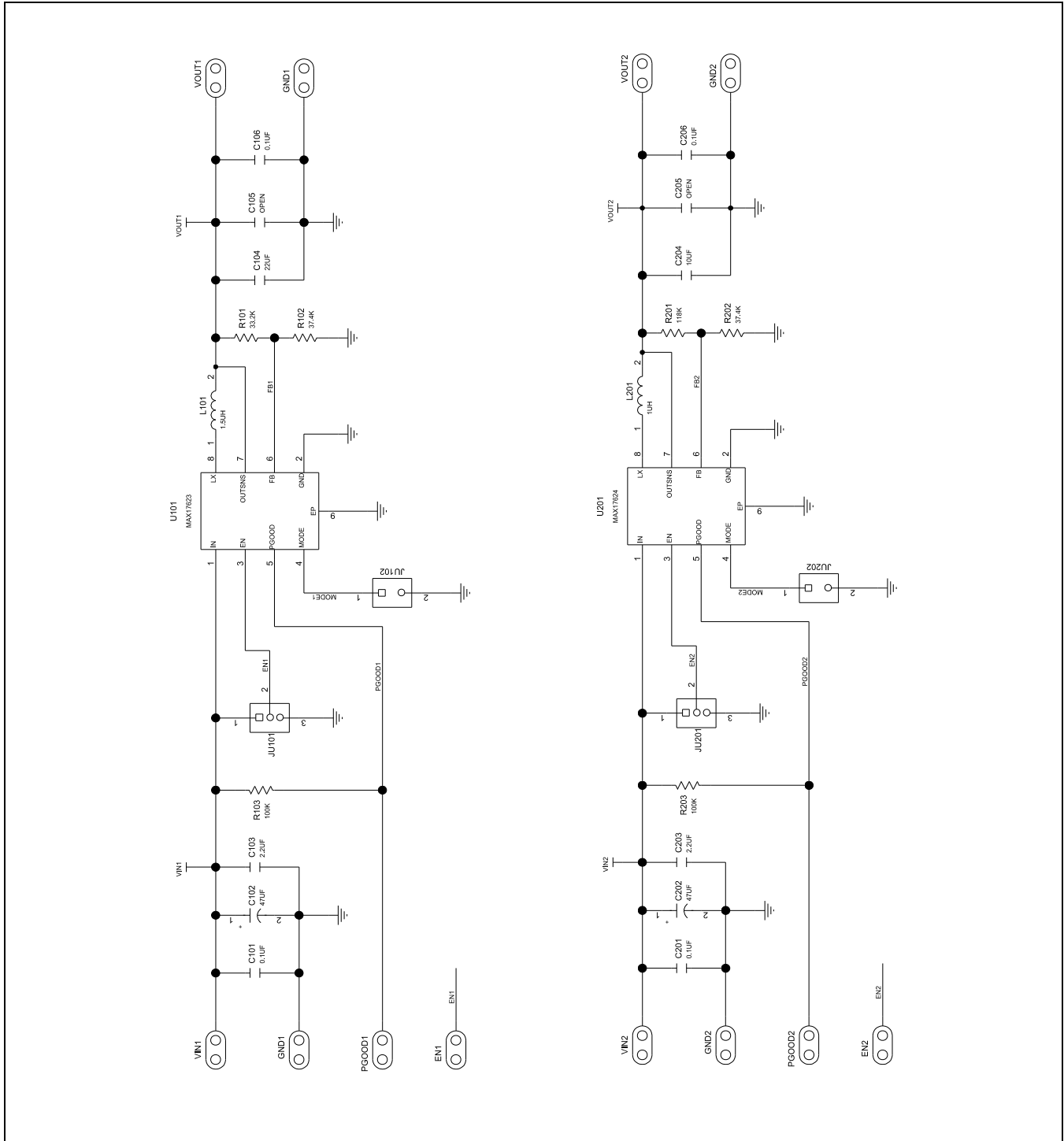

MAX17623/MAX17624 EV Kits PCB Layout Diagrams

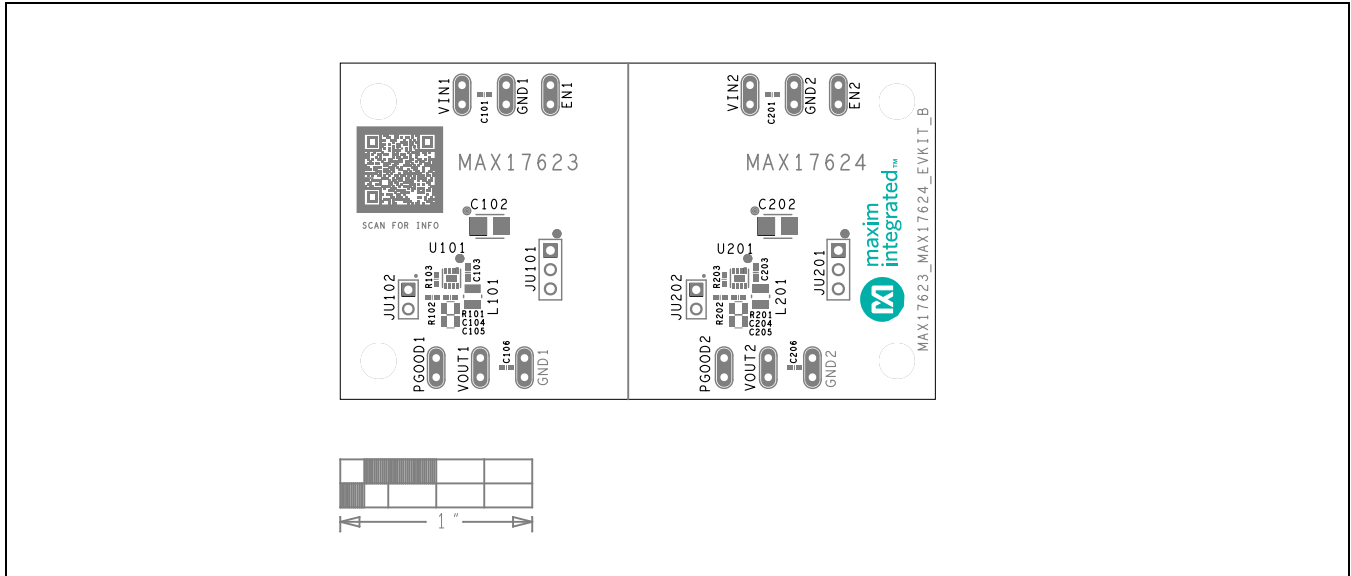

MAX17623/MAX17624 EV Kits PCB Layout—Top Silkscreen

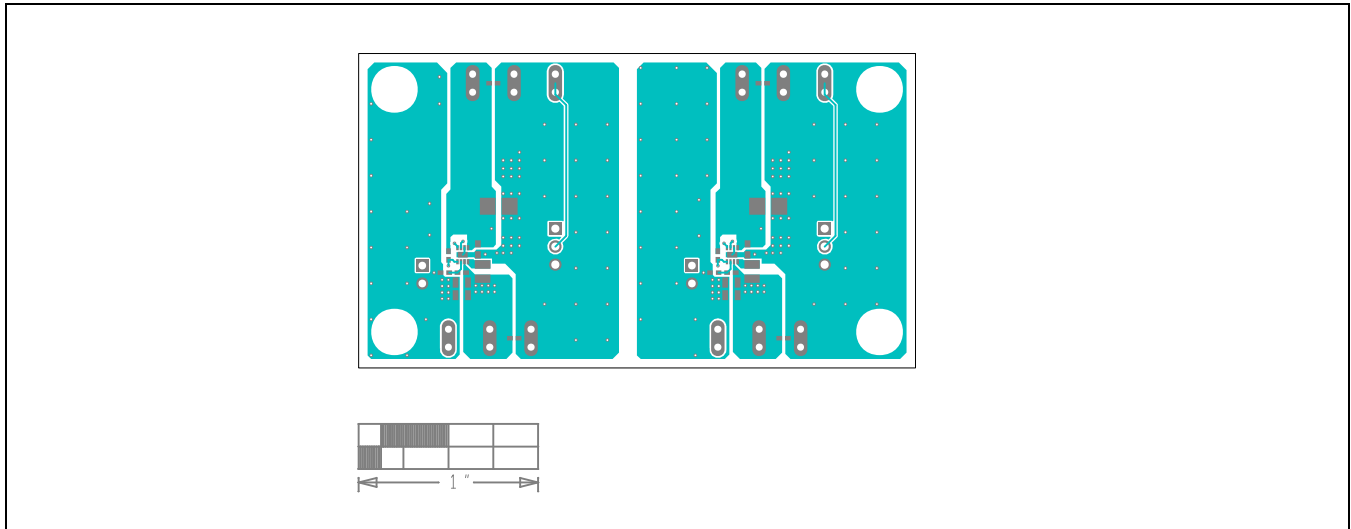

MAX17623/MAX17624 EV Kits PCB Layout—Top Layer

### MAX17623/MAX17624 EV Kits PCB Layout Diagrams

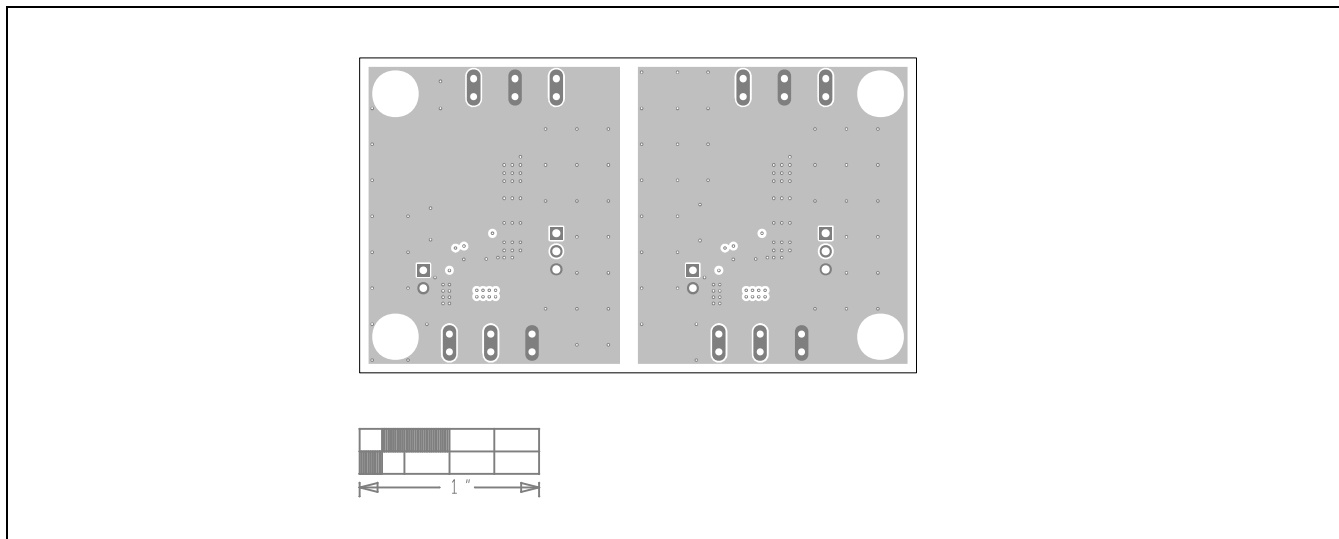

MAX17623/MAX17624 EV Kits PCB Layout—Layer 2

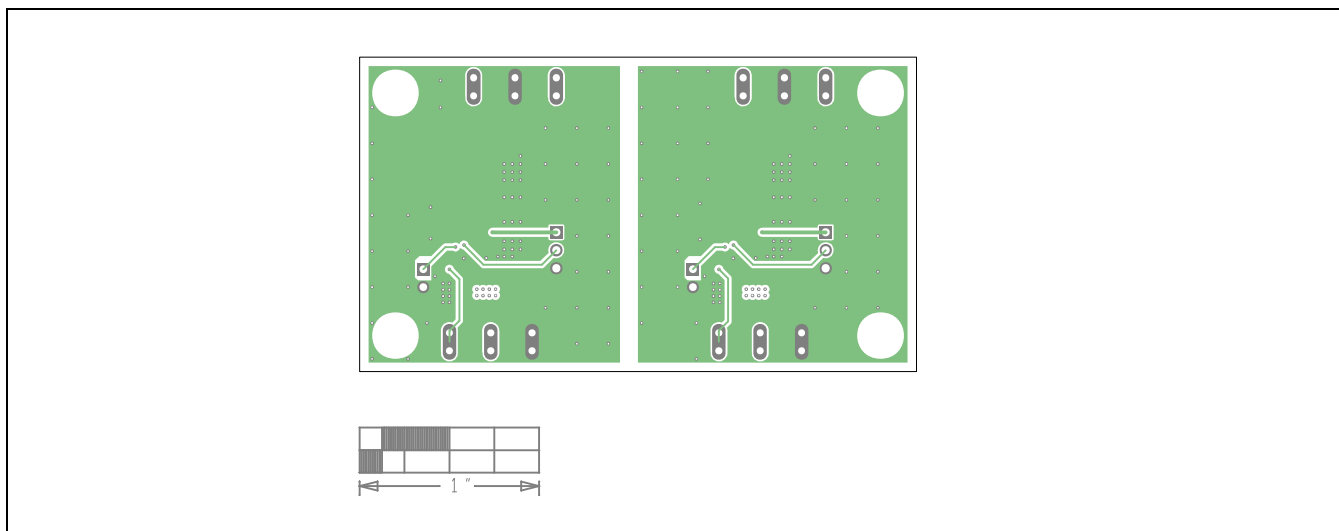

MAX17623/MAX17624 EV Kits PCB Layout—Layer 3

### MAX17623/MAX17624 EV Kits PCB Layout Diagrams

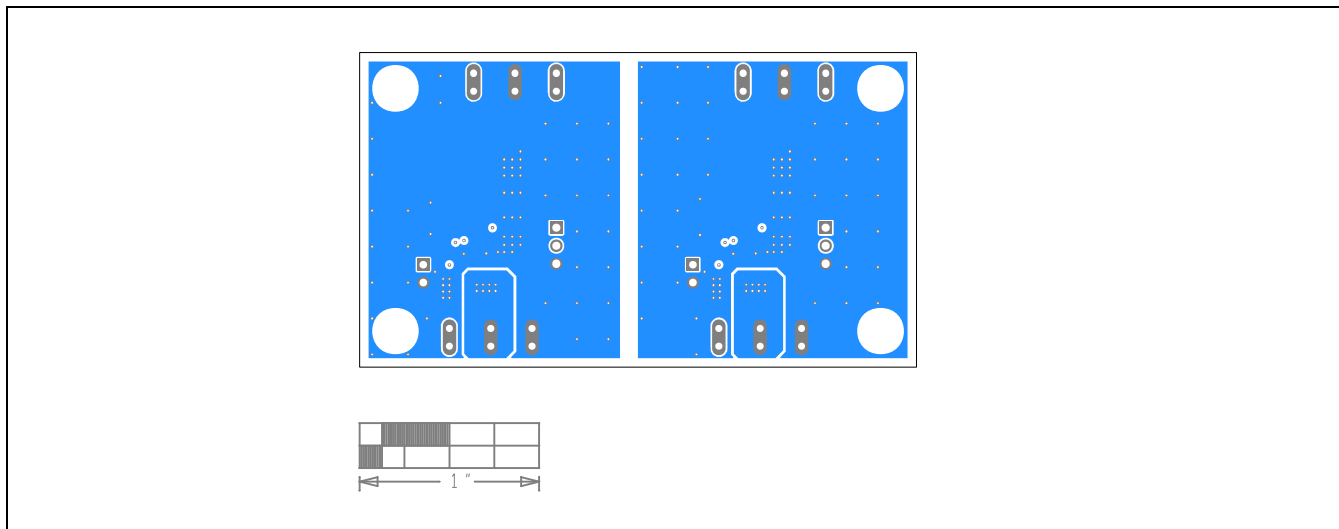

MAX17623/MAX17624 EV Kits PCB Layout—Bottom Layer

MAX17623/MAX17624

Evaluation Kits

Evaluates: MAX17623/MAX17624

Converters in Application

### Revision History

REVISION NUMBER	REVISION DATE	DESCRIPTION	PAGES CHANGED
0	12/20	Release for Market Intro	—
1	12/20	Updated the <i>Ordering Information</i> table	4

For pricing, delivery, and ordering information, please visit Maxim Integrated's online storefront at <https://www.maximintegrated.com/en/storefront/storefront.html>.

*Maxim Integrated cannot assume responsibility for use of any circuitry other than circuitry entirely embodied in a Maxim Integrated product. No circuit patent licenses are implied. Maxim Integrated reserves the right to change the circuitry and specifications without notice at any time. The parametric values (min and max limits) shown in the Electrical Characteristics table are guaranteed. Other parametric values quoted in this data sheet are provided for guidance.*

## X-ON Electronics

Largest Supplier of Electrical and Electronic Components

*Click to view similar products for [Power Management IC Development Tools](#) category:*

*Click to view products by [Maxim](#) manufacturer:*

Other Similar products are found below :

[EVAL-ADM1168LQEBZ](#) [EVB-EP5348UI](#) [MIC23451-AAAYFL EV](#) [MIC5281YMME EV](#) [DA9063-EVAL](#) [ADP122-3.3-EVALZ](#) [ADP130-0.8-EVALZ](#) [ADP130-1.2-EVALZ](#) [ADP130-1.5-EVALZ](#) [ADP130-1.8-EVALZ](#) [ADP1712-3.3-EVALZ](#) [ADP1714-3.3-EVALZ](#) [ADP1715-3.3-EVALZ](#) [ADP1716-2.5-EVALZ](#) [ADP1740-1.5-EVALZ](#) [ADP1752-1.5-EVALZ](#) [ADP1828LC-EVALZ](#) [ADP1870-0.3-EVALZ](#) [ADP1871-0.6-EVALZ](#) [ADP1873-0.6-EVALZ](#) [ADP1874-0.3-EVALZ](#) [ADP1882-1.0-EVALZ](#) [ADP199CB-EVALZ](#) [ADP2102-1.25-EVALZ](#) [ADP2102-1.875EVALZ](#) [ADP2102-1.8-EVALZ](#) [ADP2102-2-EVALZ](#) [ADP2102-3-EVALZ](#) [ADP2102-4-EVALZ](#) [ADP2106-1.8-EVALZ](#) [ADP2147CB-110EVALZ](#) [AS3606-DB](#) [BQ24010EVM](#) [BQ24075TEVM](#) [BQ24155EVM](#) [BQ24157EVM-697](#) [BQ24160EVM-742](#) [BQ24296MEVM-655](#) [BQ25010EVM](#) [BQ3055EVM](#) [NCV891330PD50GEVB](#) [ISLUSBI2CKIT1Z](#) [LM2744EVAL](#) [LM2854EVAL](#) [LM3658SD-AEV/NOPB](#) [LM3658SDEV/NOPB](#) [LM3691TL-1.8EV/NOPB](#) [LM4510SDEV/NOPB](#) [LM5033SD-EVAL](#) [LP38512TS-1.8EV](#)