

Click [here](#) for production status of specific part numbers.

## MAX17662

## 3.5V to 36V, 2A, High-Efficiency, Synchronous Step-Down DC-DC Converter

### General Description

The MAX17662 is a high-efficiency, synchronous step-down DC-DC converter with integrated MOSFETs operating over an input-voltage range of 3.5V to 36V. It can deliver up to 2A current. Output voltage is programmable from 0.6V up to 90% of  $V_{IN}$ . Built-in compensation across the output-voltage range eliminates the need for external compensation components.

The MAX17662 features a peak-current-mode control architecture. The MAX17662 can be operated in forced pulse-width modulation (PWM), or discontinuous-conduction mode (DCM) to enable high efficiency under full-load and light-load conditions. The MAX17662 offers a low minimum on-time that allows high switching frequencies and a smaller solution size.

The feedback-voltage regulation accuracy over  $-40^{\circ}\text{C}$  to  $+125^{\circ}\text{C}$  is  $\pm 1.33\%$ . The device is available in a 16-pin (3mm x 3mm) TQFN package. Simulation models are available.

### Applications

- Industrial Control Power Supplies
- General-Purpose Point-of-Load
- Distributed Supply Regulation
- Base Station Power Supplies
- Wall Transformer Regulation
- High-Voltage, Single-Board Systems

### Benefits and Features

- Reduces External Components and Total Cost
  - No Schottky—Synchronous Operation
  - Internal Compensation Components
  - All-Ceramic Capacitors, Compact Layout
- Reduces Number of DC-DC Regulators to Stock
  - Wide 3.5V to 36V Input
  - Adjustable Output Voltage Range from 0.6V up to 90% of  $V_{IN}$
  - Delivers Up to 2A Over the Temperature Range
  - 400kHz to 2.2MHz Adjustable Frequency
  - Available in a 16-pin, 3mm x 3mm TQFN Package
- Reduces Power Dissipation
  - Peak Efficiency of 95%
  - DCM Mode Enable Enhanced Light-Load Efficiency
  - Wide 2.4V to 12V Bootstrap Bias Input (EXTVCC) for Improved Efficiency
  - 6.5 $\mu\text{A}$  Shutdown Current
- Operates Reliably in Adverse Industrial Environments
  - Hiccup-Mode Overload Protection
  - Adjustable and Monotonic Startup with Prebiased Output Voltage
  - Built-in Output-Voltage Monitoring with  $\overline{\text{RESET}}$
  - Programmable EN/UVLO Threshold
  - Overtemperature Protection
  - High Industrial  $-40^{\circ}\text{C}$  to  $+125^{\circ}\text{C}$  Ambient Operating Temperature Range/ $-40^{\circ}\text{C}$  to  $+150^{\circ}\text{C}$  Junction Temperature Range

*Ordering Information appears at end of data sheet.*

### Typical Application Circuit

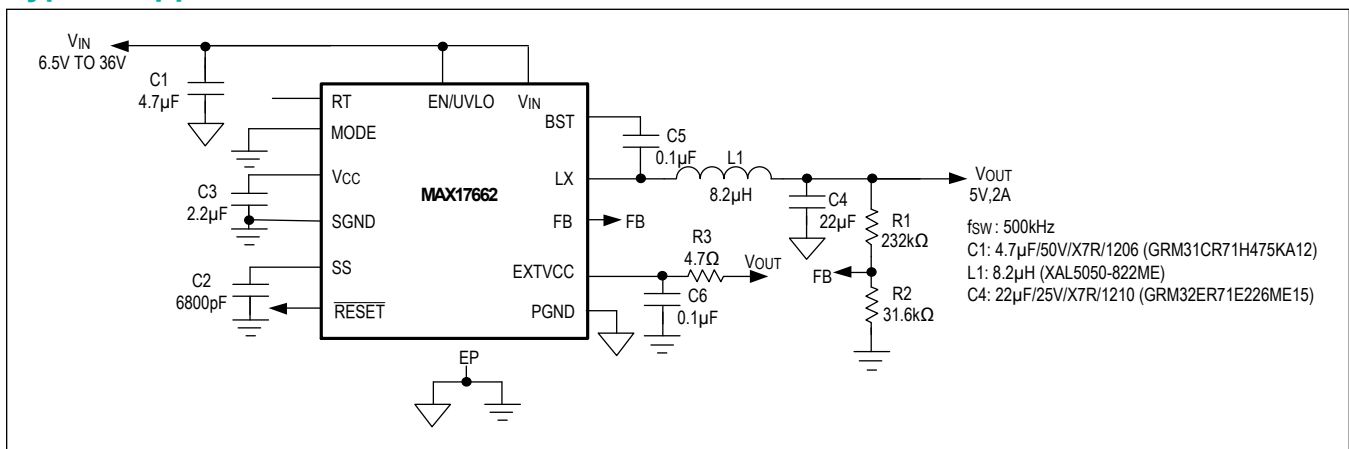

**Absolute Maximum Ratings**

V <sub>IN</sub> to PGND.....	-0.3V to +40V	LX total RMS current.....	±3.8A
EN/UVLO to SGND .....	-0.3V to +40V	Output Short-Circuit duration .....	Continuous
LX to PGND.....	-0.3V to (V <sub>IN</sub> + 0.3V)	Continuous Power Dissipation (T <sub>A</sub> = +70°C)	
EXTVCC to SGND.....	-0.3V to +14V	TQFN Multilayer Board (derate 23.1mW/°C above	
BST to PGND .....	-0.3V to +42V	+70°C).....	1847.6mW
BST to LX .....	-0.3V to +2.2V	Operating Temperature Range (Note 1) .....	-40°C to +125°C
BST to V <sub>CC</sub> .....	-0.3V to +40V	Junction Temperature .....	+150°C
FB, SS, V <sub>CC</sub> , RT to SGND .....	-0.3V to +2.2V	Storage Temperature Range .....	-65°C to +150°C
MODE, RESET to SGND .....	-0.3V to +6V	Lead Temperature (soldering, 10s).....	+300°C
PGND to SGND.....	-0.3V to +0.3V	Soldering Temperature (reflow) .....	+260°C

**Note 1:** Junction temperature greater than +125°C degrades operating lifetimes.

*Stresses beyond those listed under "Absolute Maximum Ratings" may cause permanent damage to the device. These are stress ratings only, and functional operation of the device at these or any other conditions beyond those indicated in the operational sections of the specifications is not implied. Exposure to absolute maximum rating conditions for extended periods may affect device reliability.*

**Package Information**

**TQFN**

Package Code	T1633+5C
Outline Number	<a href="#">21-0136</a>
Land Pattern Number	<a href="#">90-0032</a>
<b>Thermal Resistance, Four-Layer Board (Note 2)</b>	
Junction-to-Ambient (θ <sub>JA</sub> )	38°C/W
Junction-to-Case Thermal Resistance (θ <sub>JC</sub> )	4°C/W

For the latest package outline information and land patterns (footprints), go to [www.maximintegrated.com/packages](http://www.maximintegrated.com/packages). Note that a "+", "#", or "-" in the package code indicates RoHS status only. Package drawings may show a different suffix character, but the drawing pertains to the package regardless of RoHS status.

**Note 2:** Package thermal resistances were obtained using the MAX17662 Evaluation Kit with no airflow.

## Electrical Characteristics

( $V_{IN} = V_{EN/UVLO} = 24V$ , RT = Unconnected ( $f_{SW} = 500kHz$ ),  $C_{VCC} = 2.2\mu F$ ,  $V_{MODE} = V_{EXTVCC} = V_{SGND} = V_{PGND} = 0$ ,  $V_{FB} = 0.64V$ , LX = SS = RESET = Open,  $V_{BST}$  to  $V_{LX} = 1.8V$ ,  $T_A = T_J = -40^\circ C$  to  $125^\circ C$ , unless otherwise noted. Typical values are at  $T_A = +25^\circ C$ . All voltages are referenced to SGND, unless otherwise noted. (Note 3))

PARAMETER	SYMBOL	CONDITIONS	MIN	TYP	MAX	UNITS
<b>INPUT SUPPLY (<math>V_{IN}</math>)</b>						
Input Voltage Range	$V_{IN}$		3.5		36	V
Input Shutdown Current	$I_{IN\_SH}$	$V_{EN/UVLO} = 0V$ (Shutdown mode)		6.5	24	$\mu A$
Input Quiescent Current	$I_{Q\_DCM}$	DCM mode, $V_{LX} = 0.1V$		2		mA
	$I_{Q\_PWM}$	Normal Switching mode, $V_{FB} = 0.58V$		8.2		
Input UVLO	$V_{IN\_UVLO\_R}$	$V_{IN}$ rising	2.95		3.26	V
	$V_{IN\_HYS}$	Hysteresis		0.246		
<b>ENABLE/UVLO (<math>EN/UVLO</math>)</b>						
EN/UVLO Threshold	$V_{ENR}$	$V_{EN/UVLO}$ rising	1.194	1.25	1.303	V
	$V_{EN\_HYS}$	Hysteresis		0.1		
	$V_{EN\_TRUESD}$	$V_{EN/UVLO}$ falling, true shutdown		0.75		
EN/UVLO Input Leakage Current	$I_{EN}$	$V_{EN/UVLO} = 0V$ , $T_A = +25^\circ C$	-50	0	+50	nA
<b><math>V_{CC}</math> (LDO)</b>						
$V_{CC}$ Output Voltage Range	$V_{CC}$	$3.5V < V_{IN} < 36V$ , $I_{VCC} = 1mA$	1.74	1.80	1.86	V
		$1mA < I_{VCC} < 25mA$	1.70	1.80	1.86	
$V_{CC}$ UVLO	$V_{CC\_UVR}$	$V_{CC}$ rising	1.605	1.640	1.683	V
	$V_{CC\_HYS}$	Hysteresis		0.065		
<b>EXTVCC (EXT LDO)</b>						
EXTVCC Operating Voltage Range			2.448		12	V
EXTVCC Switchover Threshold		EXTVCC rising	2.348	2.400	2.448	V
		Hysteresis		0.09		
EXTVCC Shutdown Current		$V_{EN/UVLO} = 0$ , $EXTVCC = 12V$			19	$\mu A$
<b>POWER MOSFETS</b>						
High-Side nMOS On-Resistance	$R_{DS\_ONH}$	$I_{LX} = 0.3A$ , sourcing		130	250	m $\Omega$
Low-Side nMOS On-Resistance	$R_{DS\_ONL}$	$I_{LX} = 0.3A$ , sinking		90	170	m $\Omega$
LX Leakage Current	$I_{LX\_LKG}$	$V_{IN} = 36V$ , $T_A = +25^\circ C$ , $V_{LX} = (V_{PGND} + 1)V$ to $(V_{IN} - 1)V$ , $V_{EN/UVLO} = 0V$	-2		+2	$\mu A$
<b>SOFT-START (SS)</b>						
Charging Current	$I_{SS}$	$V_{SS} = 0.3V$	4.7	5	5.3	$\mu A$
<b>FEEDBACK (FB)</b>						
FB Regulation Voltage	$V_{FB\_REG}$	$V_{MODE} = V_{SGND}$	0.592	0.600	0.608	V
		$V_{MODE} = V_{CC}$	0.592	0.600	0.608	
FB Input Bias Current	$I_{FB}$	$V_{FB} = 1V$ , $T_A = +25^\circ C$	-50		+50	nA

**Electrical Characteristics (continued)**

( $V_{IN} = V_{EN/UVLO} = 24V$ ,  $R_T = \text{Unconnected}$  ( $f_{SW} = 500kHz$ ),  $C_{VCC} = 2.2\mu F$ ,  $V_{MODE} = V_{EXTVCC} = V_{SGND} = V_{PGND} = 0$ ,  $V_{FB} = 0.64V$ ,  $LX = SS = \text{RESET} = \text{Open}$ ,  $V_{BST}$  to  $V_{LX} = 1.8V$ ,  $T_A = T_J = -40^\circ C$  to  $125^\circ C$ , unless otherwise noted. Typical values are at  $T_A = +25^\circ C$ . All voltages are referenced to  $SGND$ , unless otherwise noted. (Note 3))

PARAMETER	SYMBOL	CONDITIONS	MIN	TYP	MAX	UNITS
<b>MODE</b>						
MODE Threshold	$V_{M\_DCM}$	$V_{MODE} = V_{CC}$ (DCM mode)	1.22			V
	$V_{M\_PWM}$	$V_{MODE} = V_{SGND}$ (PWM mode)			0.66	
<b>CURRENT LIMIT</b>						
Peak Current-Limit Threshold	$I_{PEAK\_LIMIT}$		2.8	3.4	4.1	A
Valley Current-Limit Threshold	$I_{VALLEY\_LIMIT}$	$V_{MODE} = V_{CC}$	-0.1	0	+0.1	A
		$V_{MODE} = V_{SGND}$		-1.8		
<b>TIMING (RT)</b>						
Switching Frequency	$f_{SW}$	$R_{RT} = 51.1k\Omega$	375	400	425	kHz
		$R_{RT} = 8.25k\Omega$	1980	2200	2420	
		$R_{RT} = \text{Open}$	475	500	525	
$V_{FB}$ Undervoltage Trip Level to Cause Hiccup	$V_{FB\_HICF}$		0.375	0.390	0.405	V
HICCUP Timeout		(Note 4)		32768		Cycles
Minimum On-Time	$t_{ON\_MIN}$			60	90	ns
Minimum Off-Time	$t_{OFF\_MIN}$		126		176	ns
<b>RESET</b>						
RESET Output Level Low	$V_{RESETL}$	$I_{RESET} = 10mA$			0.4	V
RESET Output Leakage Current	$I_{RESETLKG}$	$T_A = T_J = +25^\circ C$	-0.1		+0.1	$\mu A$
FB Threshold for RESET Deassertion	$V_{FB\_OKR}$	$V_{FB}$ rising	93.1	95.0	97.0	% of $V_{FB\_REG}$
FB Threshold for RESET Assertion	$V_{FB\_OKF}$	$V_{FB}$ falling	89.8	92.0	93.2	% of $V_{FB\_REG}$
RESET Delay After FB Reaches 95% Regulation				1024		Cycles
<b>THERMAL SHUTDOWN (TEMP)</b>						
Thermal-Shutdown Threshold		Temperature rising		155		$^\circ C$
Thermal-Shutdown Hysteresis				20		$^\circ C$

**Note 3:** Electrical specifications are production tested at  $T_A = +25^\circ C$ . Specifications over the entire operating temperature range are guaranteed by design and characterization.

**Note 4:** See [Overcurrent Protection/Hiccup Mode](#) section for more details.

Typical Operating Characteristics

(( $V_{EN}/UVLO = V_{IN} = 24V$ ,  $V_{SGND} = V_{PGND} = 0V$ ,  $C_{VCC} = 2.2\mu F$ ,  $C_{BST} = 0.1\mu F$ ,  $C_{SS} = 6800pF$ ,  $T_A = -40^{\circ}C$  to  $+125^{\circ}C$ , unless otherwise noted. Typical values are at  $T_A = +25^{\circ}C$ . All voltages are referenced to SGND, unless otherwise noted.))

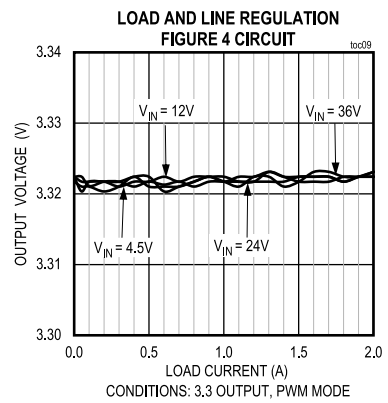
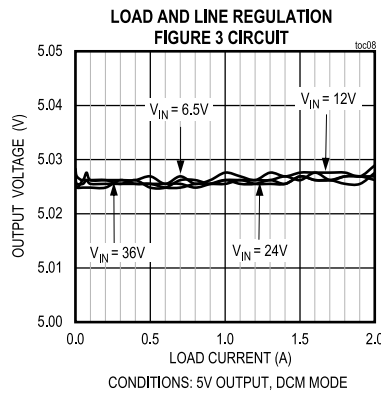
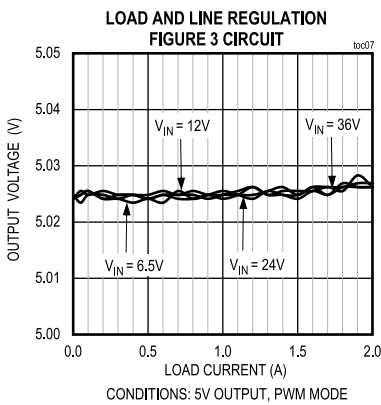
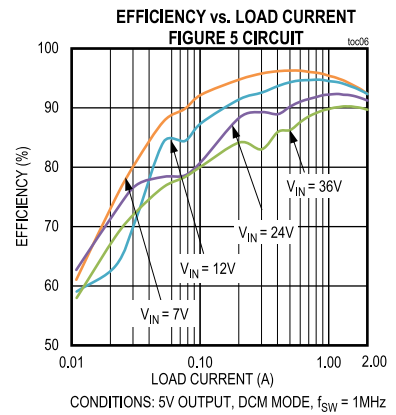
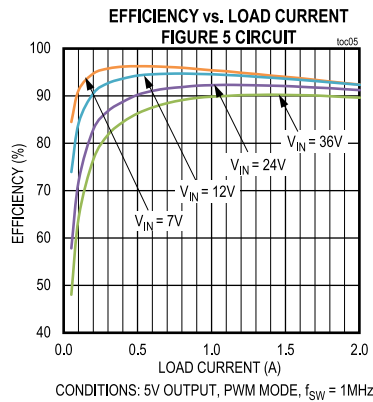
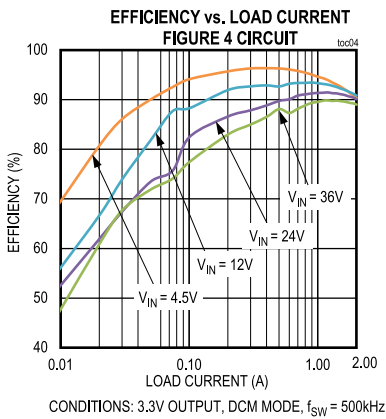
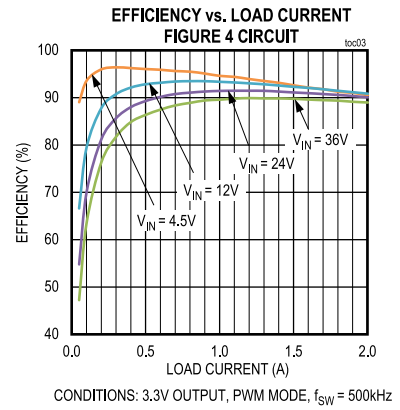
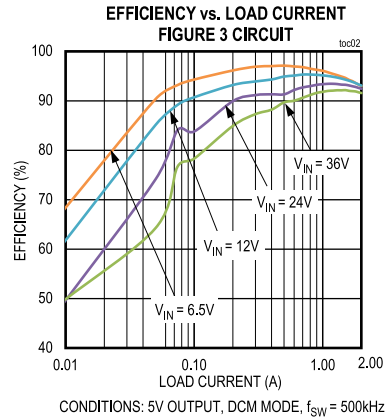
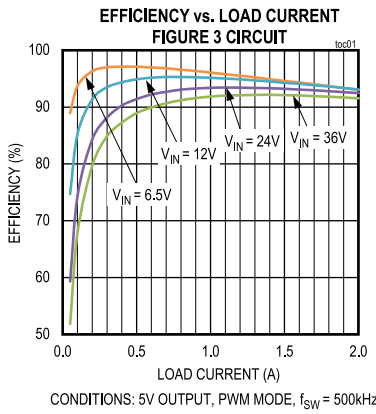

Typical Operating Characteristics (continued)

(( $V_{EN/UVLO} = V_{IN} = 24V$ ,  $V_{SGND} = V_{PGND} = 0V$ ,  $C_{VCC} = 2.2\mu F$ ,  $C_{BST} = 0.1\mu F$ ,  $C_{SS} = 6800pF$ ,  $T_A = -40^{\circ}C$  to  $+125^{\circ}C$ , unless otherwise noted. Typical values are at  $T_A = +25^{\circ}C$ . All voltages are referenced to SGND, unless otherwise noted.))

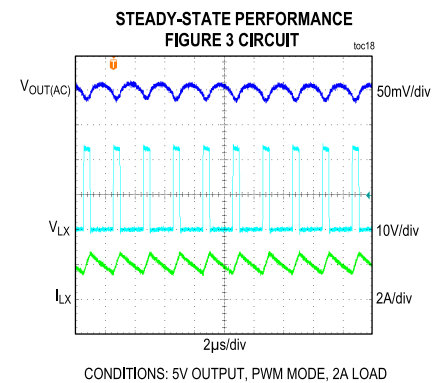
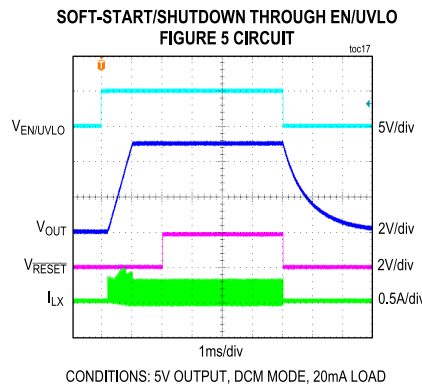
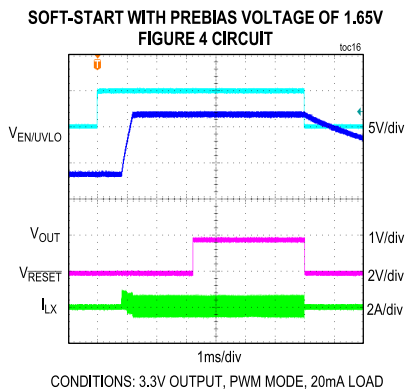
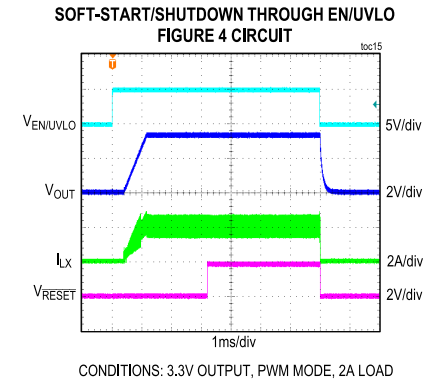
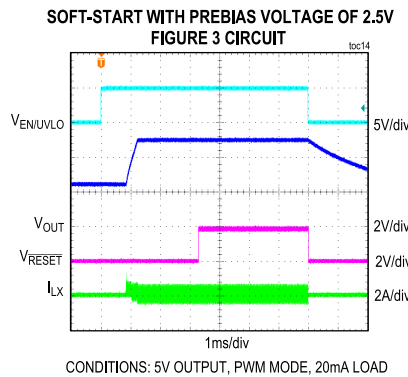
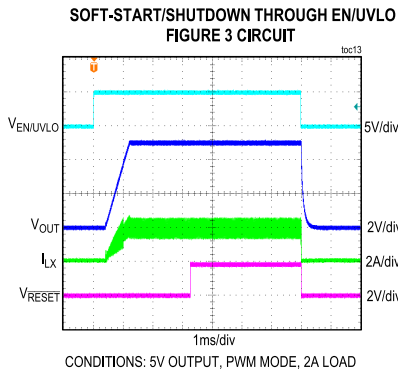
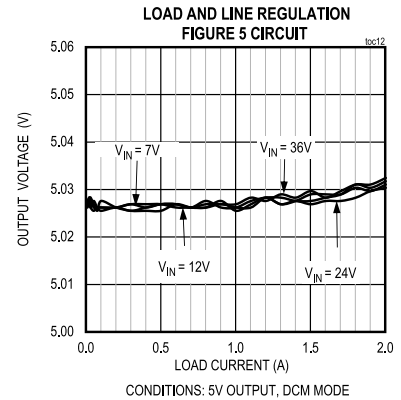
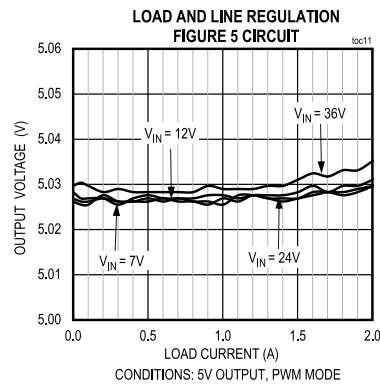
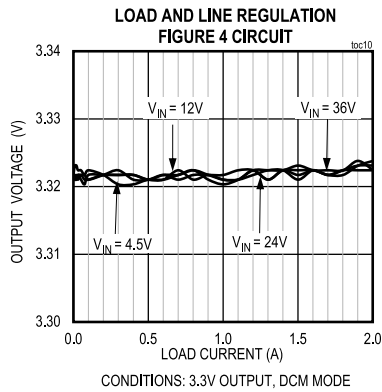

Typical Operating Characteristics (continued)

(( $V_{EN}/UVLO = V_{IN} = 24V$ ,  $V_{SGND} = V_{PGND} = 0V$ ,  $C_{VCC} = 2.2\mu F$ ,  $C_{BST} = 0.1\mu F$ ,  $C_{SS} = 6800pF$ ,  $T_A = -40^{\circ}C$  to  $+125^{\circ}C$ , unless otherwise noted. Typical values are at  $T_A = +25^{\circ}C$ . All voltages are referenced to SGND, unless otherwise noted.))

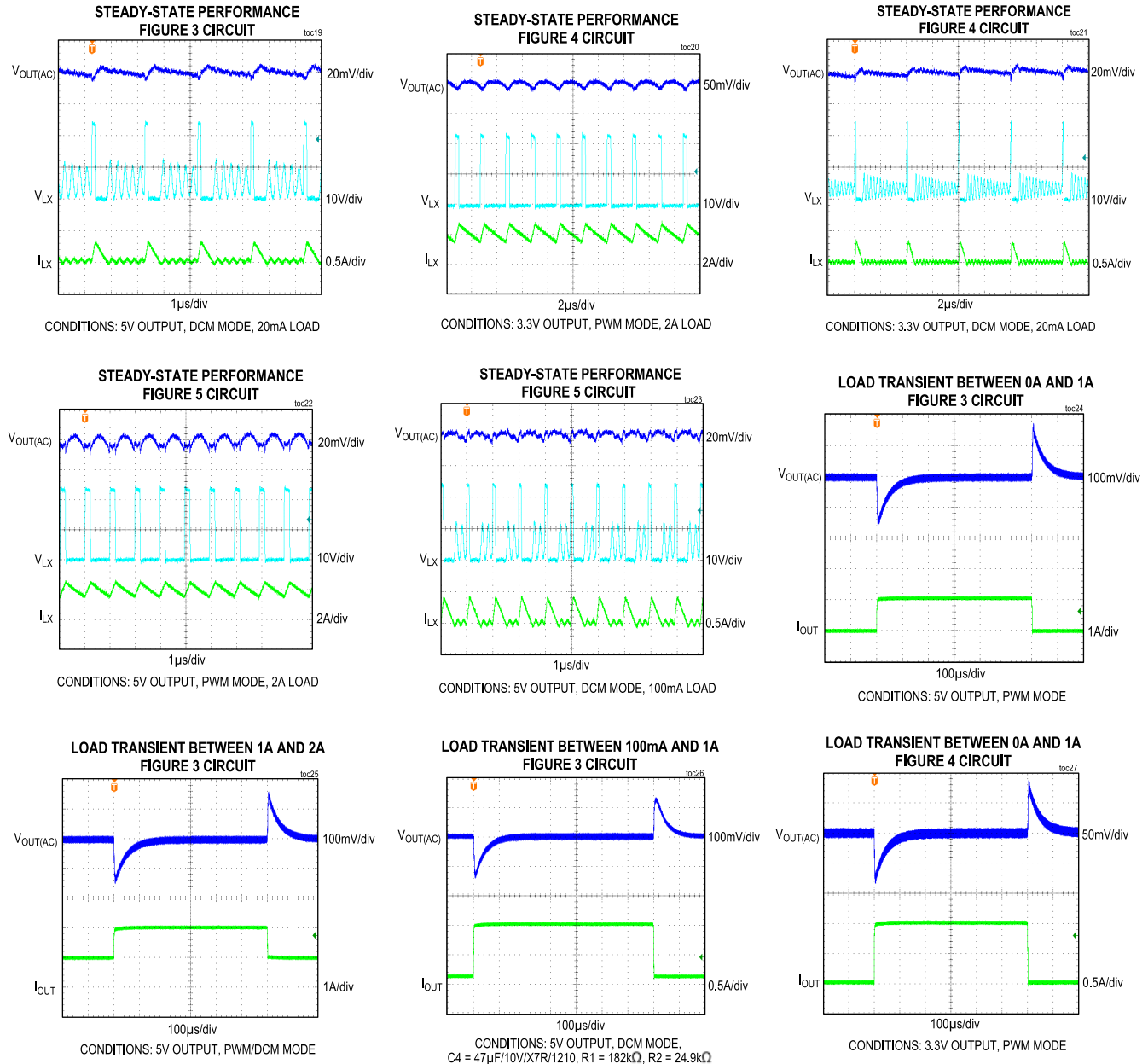

Typical Operating Characteristics (continued)

(( $V_{EN}/UVLO = V_{IN} = 24V$ ,  $V_{SGND} = V_{PGND} = 0V$ ,  $C_{VCC} = 2.2\mu F$ ,  $C_{BST} = 0.1\mu F$ ,  $C_{SS} = 6800pF$ ,  $T_A = -40^{\circ}C$  to  $+125^{\circ}C$ , unless otherwise noted. Typical values are at  $T_A = +25^{\circ}C$ . All voltages are referenced to SGND, unless otherwise noted.))

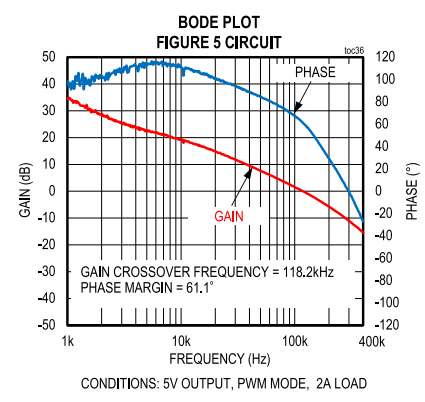
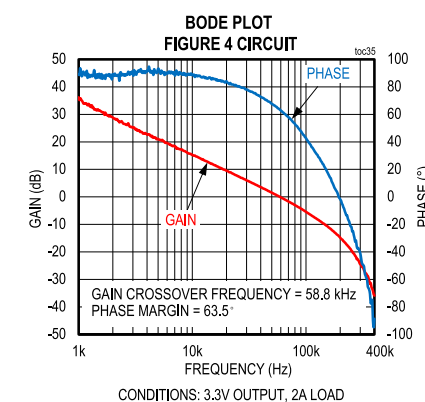
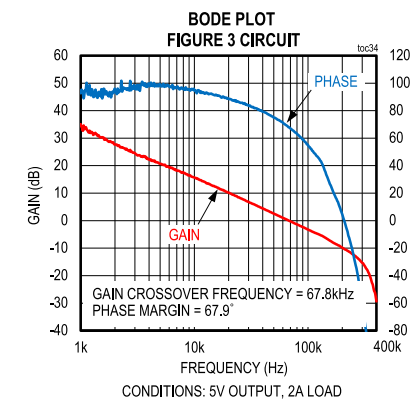
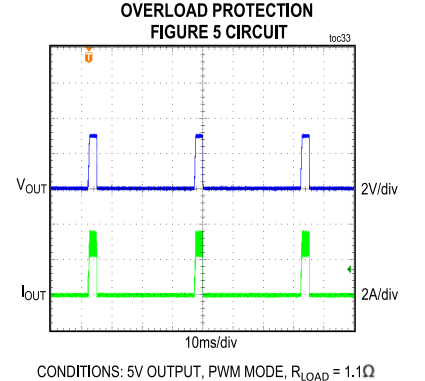
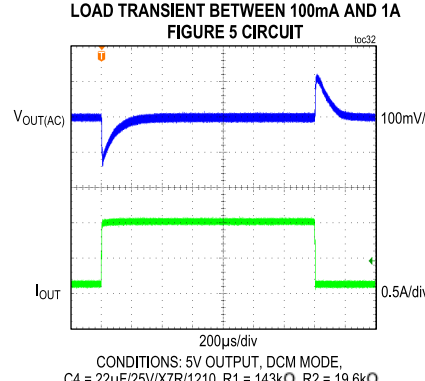
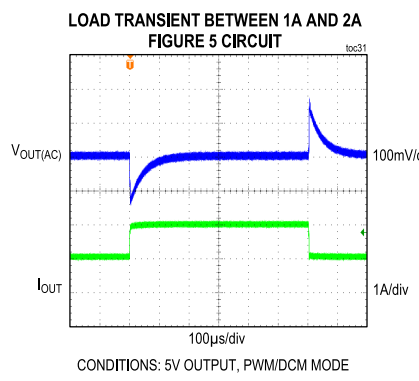
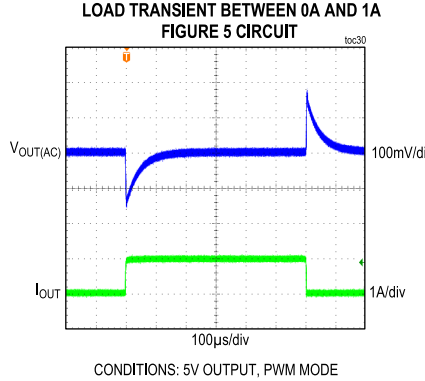
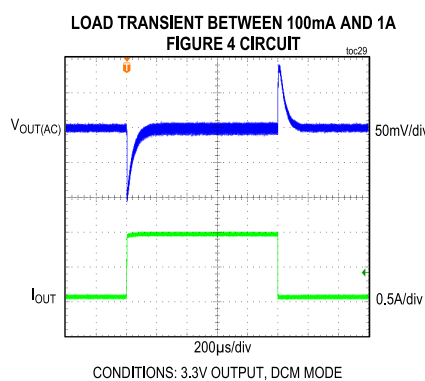
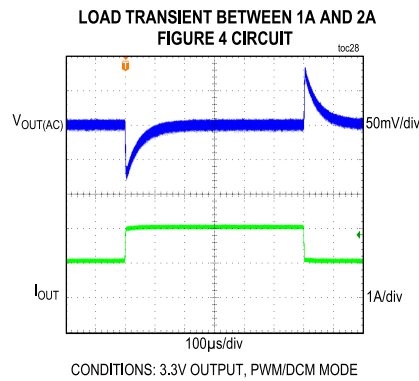



Typical Operating Characteristics (continued)

(( $V_{EN/UVLO} = V_{IN} = 24V$ ,  $V_{SGND} = V_{PGND} = 0V$ ,  $C_{VCC} = 2.2\mu F$ ,  $C_{BST} = 0.1\mu F$ ,  $C_{SS} = 6800pF$ ,  $T_A = -40^{\circ}C$  to  $+125^{\circ}C$ , unless otherwise noted. Typical values are at  $T_A = +25^{\circ}C$ . All voltages are referenced to SGND, unless otherwise noted.))

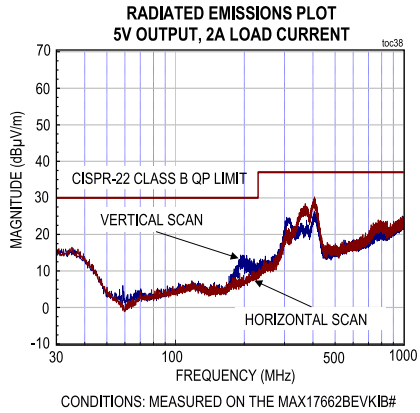
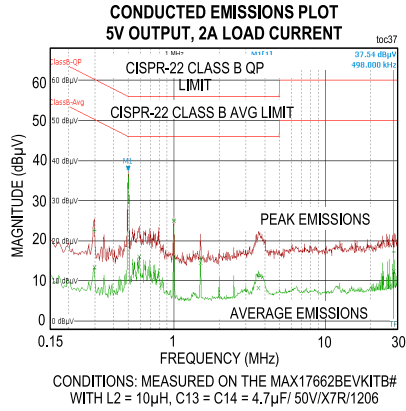

Pin Configuration

16 TQFN

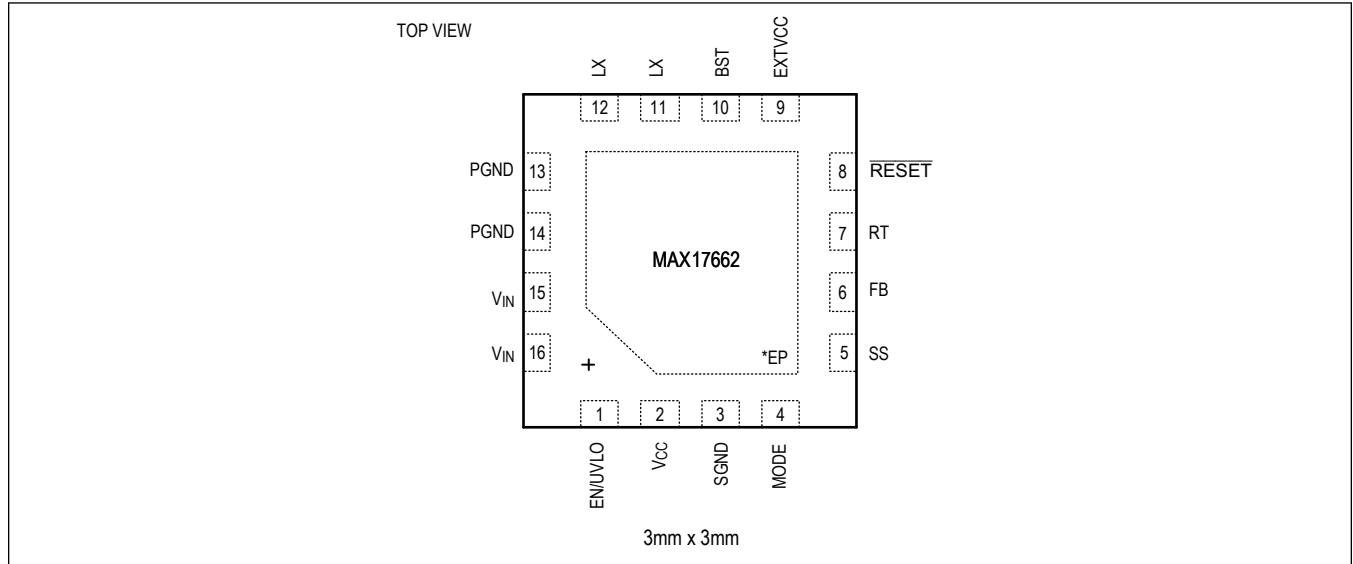

Pin Description

PIN	NAME	FUNCTION
1	EN/UVLO	Enable/Undervoltage Lockout Pin. Drive EN/UVLO high to enable the output. Connect to the center of the resistor-divider between $V_{IN}$ and SGND to set the input voltage at which the part turns on. Connect to $V_{IN}$ pins for always-on operation. Pull low (lower than $V_{EN\_TRUESD}$ ) for disabling the device.
2	$V_{CC}$	1.8V LDO Output. Bypass $V_{CC}$ with a 2.2 $\mu$ F ceramic capacitance to SGND. LDO does not support the external loading on $V_{CC}$
3	SGND	Signal Ground
4	MODE	The MODE pin configures the device to operate in either PWM or DCM modes of operation. Connect MODE to SGND for constant-frequency PWM operation at all loads. Connect MODE to $V_{CC}$ for DCM operation (at light loads). See the <a href="#">Mode Selection (MODE)</a> section for more details.
5	SS	Soft-Start Input. Connect a capacitor from SS to SGND to set the soft-start time.
6	FB	Feedback Input. Connect FB to the center node of an external resistor-divider from the output to SGND to set the output voltage. See the <a href="#">Adjusting Output Voltage</a> section for more details.
7	RT	Programmable Switching Frequency Input. Connect a resistor from RT to SGND to set the regulator's switching frequency between 400kHz and 2.2MHz. Leave RT pin open for the default 500kHz frequency. See the <a href="#">Setting the Switching Frequency (RT)</a> section for more details.
8	$\overline{\text{RESET}}$	Open-Drain $\overline{\text{RESET}}$ Output. The $\overline{\text{RESET}}$ output is driven low if FB drops below $V_{FB\_OKF}$ . $\overline{\text{RESET}}$ goes high 1024 cycles after FB rises above $V_{FB\_OKR}$ .
9	EXTVCC	External Power Supply Input. Applying a voltage between 2.448V and 12V at EXTVCC will bypass the internal LDO and improve overall converter efficiency. Connect a buck regulator output to EXTVCC through an RC filter (4.7 $\Omega$ , 0.1 $\mu$ F) to protect the EXTVCC pin from reaching its absolute maximum rating (-0.3V) during an output short-circuit condition. When EXTVCC is not used, connect it to SGND.
10	BST	Boost Flying Capacitor. Connect a 0.1 $\mu$ F ceramic capacitor between BST and LX.

**Pin Description (continued)**

<b>PIN</b>	<b>NAME</b>	<b>FUNCTION</b>
11, 12	LX	Switching Node Pins. Connect LX pins to the switching side of the inductor.
13, 14	PGND	Power Ground Pins of the Converter. Connect externally to the power ground plane. Refer to the MAX17662 Evaluation Kit data sheet for a layout example.
15, 16	V <sub>IN</sub>	Power-Supply Input Pins. 3.5V to 36V input-supply range. Decouple to PGND with a minimum 2.2µF capacitor; place the capacitor close to the V <sub>IN</sub> and PGND pins. See <a href="#">Input Capacitor Selection</a> for more details.
—	EP	Exposed Pad. Always connect EP to the SGND pin of the IC. Also, connect EP to a large plane with several thermal vias for best thermal performance. Refer to the MAX17662 Evaluation Kit data sheet for an example of the correct method for EP connection and thermal vias.

Block Diagram

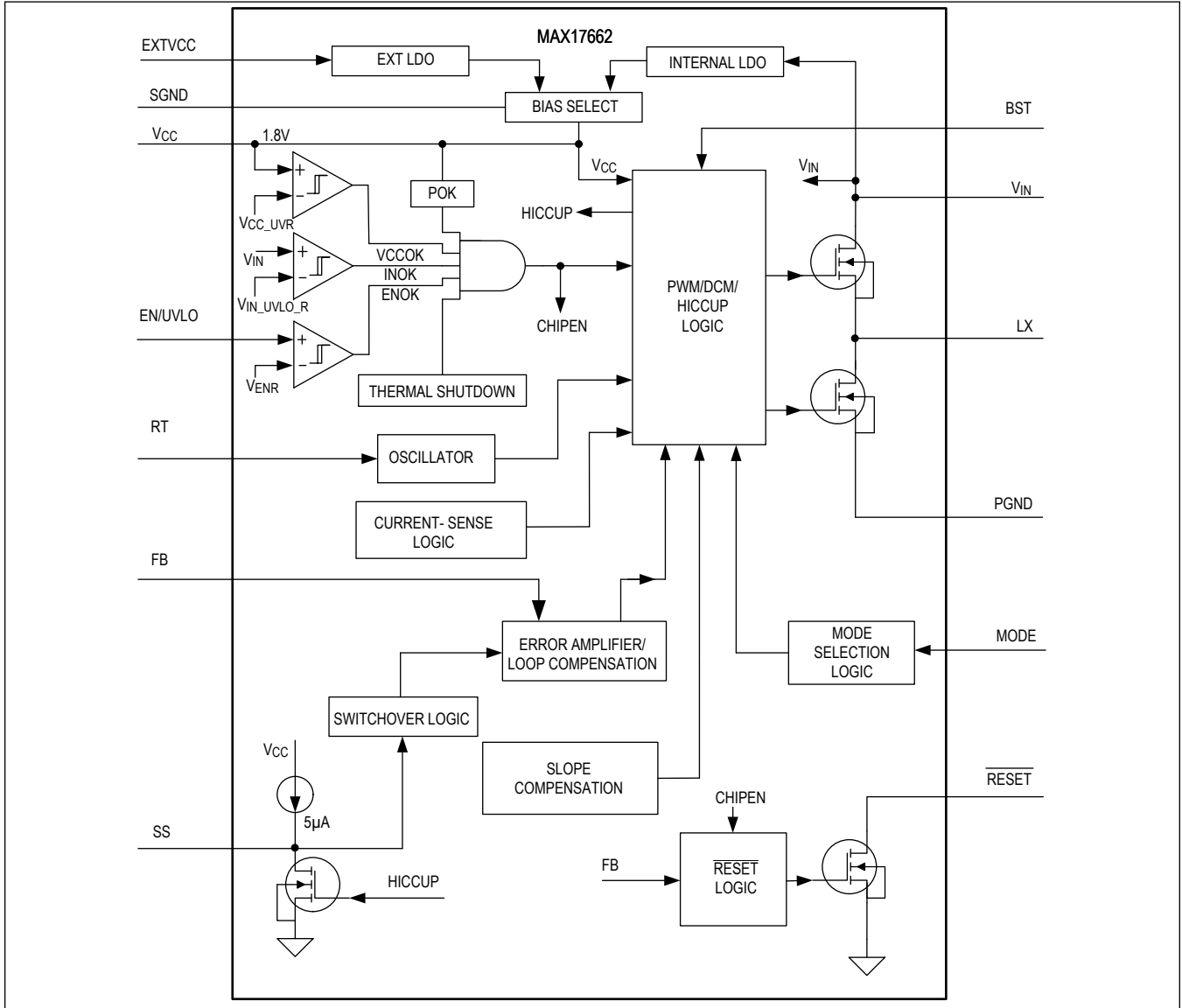

## Detailed Description

The MAX17662 is a high-efficiency, synchronous step-down DC-DC converter with integrated MOSFETs. It can deliver up to 2A over an input voltage range of 3.5V to 36V. Built-in compensation across the output-voltage range eliminates the need for external compensation components. The feedback-voltage regulation accuracy over  $-40^{\circ}\text{C}$  to  $+125^{\circ}\text{C}$  is  $\pm 1.33\%$ .

The device features a peak-current-mode control architecture. An internal transconductance error amplifier produces an integrated error voltage at an internal node, which sets the duty cycle using a PWM comparator, a high-side current-sense amplifier, and a slope-compensation generator. At each rising edge of the clock, the high-side MOSFET turns on and remains on until either the appropriate or maximum duty cycle is reached, or the peak current limit is detected. During the high-side MOSFET's on-time, the inductor current ramps up. During the second half of the switching cycle, the high-side MOSFET turns off and the low-side MOSFET turns on. The inductor releases the stored energy as its current ramps down and provides current to the output.

The device features a MODE pin that can be used to operate the device in PWM or DCM mode. The device also features adjustable-input undervoltage lockout, adjustable soft-start, and output voltage monitoring with open-drain  $\overline{\text{RESET}}$ . The MAX17662 offers a low minimum on time that allows high switching frequencies and a smaller solution size.

### Mode Selection (MODE)

The MAX17662 supports forced PWM and DCM mode of operation. The device enters the required mode of operation based on the setting of the MODE pin as detected during power-up after  $V_{\text{IN}}$ ,  $V_{\text{CC}}$ , and EN/UVLO voltages exceed their respective UVLO rising thresholds ( $V_{\text{IN\_UVLO\_R}}$ ,  $V_{\text{CC\_UVR}}$ ,  $V_{\text{ENR}}$ ). If the state of the MODE pin is high ( $> V_{\text{M\_DCM}}$ ), the device operates in DCM mode at light loads. If the state of the MODE pin is low ( $< V_{\text{M\_PWM}}$ ), the device operates in constant-frequency PWM mode at all loads. See the MODE section in the [Electrical Characteristics](#) table for details.

### PWM Mode Operation

In PWM mode, the inductor current is allowed to go negative. PWM operation provides constant frequency operation at all loads and is useful in applications sensitive to switching frequency. However, the PWM mode of operation gives lower efficiency at light loads compared to the DCM mode of operation.

### DCM Mode Operation

In DCM mode of operation, the inductor current can be discontinuous at light loads. The inductor current is not allowed to go negative. Switching pulses are skipped when the buck converter is operated close to no-load condition. DCM operation offers better efficiency performance compared to PWM at light loads. The steady-state output voltage ripple in DCM mode is comparable to PWM mode.

### Linear Regulator ( $V_{\text{CC}}$ and EXT $V_{\text{CC}}$ )

The MAX17662 has two built-in low dropout (LDO) linear regulators that power  $V_{\text{CC}}$ . One LDO is powered from  $V_{\text{IN}}$  (internal LDO), while the other LDO is powered from EXT $V_{\text{CC}}$  (EXT LDO). The internal LDO is enabled either during power-up or when voltage on EN/UVLO pin is recycled. Only one of the two LDOs is in operation at a time, depending on the voltage present at EXT $V_{\text{CC}}$ . If EXT $V_{\text{CC}}$  is greater than 2.4V (typ),  $V_{\text{CC}}$  is powered by EXT LDO. Powering  $V_{\text{CC}}$  from EXT $V_{\text{CC}}$  increases efficiency at higher input voltages. The typical  $V_{\text{CC}}$  output voltage is 1.8V. Bypass  $V_{\text{CC}}$  to SGND with a 2.2 $\mu\text{F}$  low-ESR ceramic capacitor.  $V_{\text{CC}}$  powers the internal blocks and the low-side MOSFET driver.  $V_{\text{CC}}$  also recharges the external bootstrap capacitor.

The MAX17662 employs an undervoltage-lockout circuit that forces the buck converter off when  $V_{\text{CC}}$  falls below the falling threshold ( $V_{\text{CC\_UVR}} - V_{\text{CC\_HYS}}$ ). The buck converter can be immediately enabled again when  $V_{\text{CC}} > V_{\text{CC\_UVR}}$ . The 65mV (typ) UVLO hysteresis prevents chattering on power-up/power-down.

If the buck converter output is shorted to ground in applications where the converter output is connected to the EXT $V_{\text{CC}}$  pin, then the transfer from EXT LDO to the internal LDO happens seamlessly, without any impact to normal functionality. Add a local bypass capacitor of 0.1 $\mu\text{F}$  on the EXT $V_{\text{CC}}$  pin to SGND, and a 4.7 $\Omega$  resistor from the buck regulator output

node to the EXTVCC pin, to protect the EXTVCC pin from reaching its absolute maximum rating (-0.3V) during output short-circuit conditions. Connect EXTVCC pin to SGND when not in use.

### Setting the Switching Frequency (RT)

The switching frequency of the device can be programmed between 400kHz and 2.2MHz by using a resistor connected from the RT pin to SGND. The switching frequency ( $f_{SW}$ ) is related to the resistor connected at the RT pin ( $R_{RT}$ ) by the following equation:

$$R_{RT} = \frac{20625}{f_{SW}} - 1$$

where,  $R_{RT}$  is in k $\Omega$  and  $f_{SW}$  is in kHz. Leaving the RT pin open makes the device operate at the default switching frequency of 500kHz. See [Table 1](#) for RT resistor values for a few common switching frequencies.

**Table 1. Switching Frequency vs. RT Resistor**

SWITCHING FREQUENCY (kHz)	RT RESISTOR (k $\Omega$ )
400	51.1
500	Open
500	40.2
2200	8.25

### Operating Input Voltage Range

The minimum and maximum operating input voltages for a given output voltage setting should be calculated as follows:

$$V_{IN(MIN)} = \frac{V_{OUT} + (I_{OUT(MAX)} \times (R_{DCR(MAX)} + R_{DS\_ONL(MAX)}))}{1 - (f_{SW(MAX)} \times t_{OFF\_MIN(MAX)})} + (I_{OUT(MAX)} \times (R_{DS\_ONH(MAX)} - R_{DS\_ONL(MAX)}))$$

$$V_{IN(MAX)} = \frac{V_{OUT}}{f_{SW(MAX)} \times t_{ON\_MIN(MAX)}}$$

where:

$V_{OUT}$  = Programmed steady-state output voltage

$I_{OUT(MAX)}$  = Maximum load current

$R_{DCR(MAX)}$  = Worst-case DC resistance of the inductor

$f_{SW(MAX)}$  = Maximum switching frequency

$t_{OFF\_MIN(MAX)}$  = Worst-case minimum switch off-time (176ns)

$t_{ON\_MIN(MAX)}$  = Worst-case minimum switch on-time (90ns)

$R_{DS\_ONL(MAX)}$  and  $R_{DS\_ONH(MAX)}$  = Worst-case on-state resistances of low-side and high-side internal MOSFETs, respectively.

The minimum input voltage ( $V_{IN\_SU}$ ) for startup/restart of the buck converter should be as follows:

$$V_{IN\_SU} \geq V_{OUT\_BIAS} + 1.8$$

where:

$V_{OUT\_BIAS}$  = Prebias voltage on output node.

The maximum slew rate that can be applied on input voltage is 30V/ $\mu$ sec.

### Overcurrent Protection (OCP)/Hiccup Mode

The device is provided with a robust overcurrent-protection (OCP) scheme that protects the device under overload and output short-circuit conditions. A cycle-by-cycle peak current limit turns off the high-side MOSFET whenever the high-side switch current exceeds an internal limit of  $I_{PEAK\_LIMIT}$  (3.4A (typ)). The short-circuit protection scheme protects the device by using an hysteretic control of the current during the soft start and by using the feedback under voltage fault in steady state. In hysteretic control, the positive current limit is triggered when the peak value of the inductor current hits a fixed threshold ( $I_{PEAK\_LIMIT} - 3.4A$ , typ). At this point, the high-side switch is turned off and the low-side switch is turned on. The low-side switch is kept on until the inductor current reduces below  $0.7 \times I_{PEAK\_LIMIT}$ . If the feedback voltage drops below  $V_{FB\_HICF}$  due to a fault condition any time after soft-start is completed, then the hiccup mode is activated.

In hiccup mode, the converter is protected by suspending switching for a hiccup timeout period of 32,768 clock cycles of the switching frequency. Once the hiccup timeout period expires, soft-start is attempted again. Note that when soft-start is attempted under overload condition, if feedback voltage does not exceed  $V_{FB\_HICF}$ , the device continues to switch in hysteretic control for the duration of the programmed soft-start time and 2048 clock cycles. Hiccup mode of operation ensures low average power dissipation under output short-circuit conditions.

### RESET Output

The device includes a  $\overline{RESET}$  comparator to monitor the status of the output voltage. The open-drain  $\overline{RESET}$  output requires an external pullup resistor.  $\overline{RESET}$  goes high (high impedance) 1024 switching cycles after the FB voltage increases above  $V_{FB\_OKR}$ .  $\overline{RESET}$  goes low when the FB voltage drops to below  $V_{FB\_OKF}$ .  $\overline{RESET}$  also goes low during thermal shutdown or when the EN/UVLO pin goes below EN/UVLO falling threshold ( $V_{ENR} - V_{EN\_HYS}$ ).

### Prebiased Output

When the device starts into a prebiased output, the minimum input voltage ( $V_{IN\_SU}$ ) to enable buck converter startup should be calculated as follows:

$$V_{IN\_SU} \geq V_{OUT\_BIAS} + 1.8$$

where:

$V_{OUT\_BIAS}$  = Prebias voltage on output node.

In a prebiased output condition, both the high-side and the low-side switches are turned off so that the converter does not sink current from the output. High-side and low-side switches do not start switching until the PWM comparator commands the first PWM pulse, at which point switching commences. The output voltage is then smoothly ramped up to the target value in alignment with the internal reference.

### Thermal Shutdown Protection

Thermal shutdown protection limits junction temperature of the device. When the junction temperature of the device exceeds +155°C, an on-chip thermal sensor shuts down the device, allowing the device to cool. The device turns on with soft-start after the junction temperature reduces by 20°C. Carefully evaluate the total power dissipation (see the [Power Dissipation](#) section) to avoid unwanted triggering of thermal shutdown during normal operation.

## Applications Information

### Input Capacitor Selection

The input filter capacitor reduces peak currents drawn from the power source and reduces noise and voltage ripple on the input caused by the circuit's switching. The input capacitor RMS current requirement ( $I_{RMS}$ ) is defined by the following equation:

$$I_{RMS} = I_{OUT(MAX)} \times \frac{\sqrt{V_{OUT} \times (V_{IN} - V_{OUT})}}{V_{IN}}$$

where,  $I_{OUT(MAX)}$  is the maximum load current.  $I_{RMS}$  has a maximum value when the input voltage equals twice the output voltage ( $V_{IN} \approx 2 \times V_{OUT}$ ), so

$$I_{RMS(MAX)} = \frac{I_{OUT(MAX)}}{2}$$

Choose an input capacitor that exhibits less than +10°C temperature rise at the RMS input current for optimal long-term reliability. Use low-ESR ceramic capacitors with high-ripple-current capability at the input. X7R capacitors are recommended in industrial applications for their temperature stability. Calculate the input capacitance using the following equation:

$$C_{IN} = \frac{I_{OUT(MAX)} \times D \times (1 - D)}{\eta \times f_{SW} \times \Delta V_{IN}}$$

where:

$D = V_{OUT}/V_{IN}$  is the duty ratio of the converter

$f_{SW}$  = switching frequency

$\Delta V_{IN}$  = allowable input-voltage ripple

$\eta$  = efficiency

In applications where the source is located distant from the device input, an appropriate electrolytic capacitor should be added in parallel to the ceramic capacitor to provide necessary damping for potential oscillations caused by the inductance of the longer input power path and input ceramic capacitor.

### Inductor Selection

Three key inductor parameters must be specified for operation with the device: inductance value (L), inductor saturation current ( $I_{SAT}$ ) and DC resistance ( $R_{DCR}$ ). The switching frequency and output voltage determine the inductor value as follows:

$$L = \frac{V_{OUT}}{1.25 \times f_{SW}}$$

where  $V_{OUT}$  and  $f_{SW}$  are nominal values and  $f_{SW}$  is in Hz. Select an inductor whose value is nearest to the value calculated by the previous formula. Select a low-loss inductor closest to the calculated value with acceptable dimensions and having the lowest possible DC resistance. The saturation current rating ( $I_{SAT}$ ) of the inductor must be high enough to ensure that saturation can occur only above the peak current-limit value of  $I_{PEAK\_LIMIT}$ .



### Output Capacitor Selection

X7R ceramic output capacitors are preferred due to their stability over temperature in industrial applications. The output capacitors are usually sized to support a step load of 50% of the maximum output current in the application, so output-voltage deviation is contained to 3% of the output-voltage change. The minimum required output capacitance can be calculated as follows:

$$C_{OUT} = \frac{1}{2} \times \frac{I_{STEP} \times t_{RESPONSE}}{\Delta V_{OUT}}$$

$$t_{RESPONSE} \cong \frac{0.33}{f_C}$$

where:

$I_{STEP}$  = Load current step

$t_{RESPONSE}$  = Response time of the controller

$\Delta V_{OUT}$  = Allowable output-voltage deviation

$f_C$  = Target closed-loop crossover frequency

$f_{SW}$  = Switching frequency.

Select  $f_C$  to be 1/9th of  $f_{SW}$  if the switching frequency is less than or equal to 900kHz. If the switching frequency is more than 900kHz, select  $f_C$  to be 100kHz. Actual derating of ceramic capacitors with DC-bias voltage must be considered while selecting the output capacitor. Derating curves are available from all major ceramic capacitor manufacturers.

### Soft-Start Capacitor Selection

The device implements adjustable soft-start operation to reduce inrush current. A capacitor connected from the SS pin to SGND programs the soft-start time. The selected output capacitance ( $C_{SEL}$ ) and the output voltage ( $V_{OUT}$ ) determine the minimum required soft-start capacitor as follows:

$$C_{SS} \geq 28 \times 10^{-6} \times C_{SEL} \times V_{OUT}$$

The soft-start time ( $t_{SS}$ ) is related to the capacitor connected at SS ( $C_{SS}$ ) by the following equation:

$$t_{SS} = \frac{C_{SS}}{8.325 \times 10^{-6}}$$

For example, to program a 0.82ms soft-start time, a 6.8nF capacitor should be connected from the SS pin to SGND. Note that, during startup, the device operates at half the programmed switching frequency until the output voltage reaches 65% of set output nominal voltage.

### Setting the Input Undervoltage-Lockout Level

The device offers an adjustable input undervoltage-lockout level. Set the voltage at which the device turns on with a resistive voltage-divider connected from  $V_{IN}$  to SGND (See [Figure 1](#)). Connect the center node of the divider to EN/UVLO. Choose R1 to be 3.3M $\Omega$  and then calculate R2 as follows:

$$R2 = \frac{R1 \times 1.25}{(V_{INU} - 1.25)}$$

where  $V_{INU}$  is the input-voltage level at which the device is required to turn on. Ensure that  $V_{INU}$  is higher than  $0.8 \times V_{OUT}$  to avoid hiccup during slow power-up (slower than soft-start)/power-down. If the EN/UVLO pin is driven from an external signal source, a series resistance of minimum 1k $\Omega$  is recommended to be placed between the output pin of signal source and the EN/UVLO pin, to reduce voltage ringing on the line.

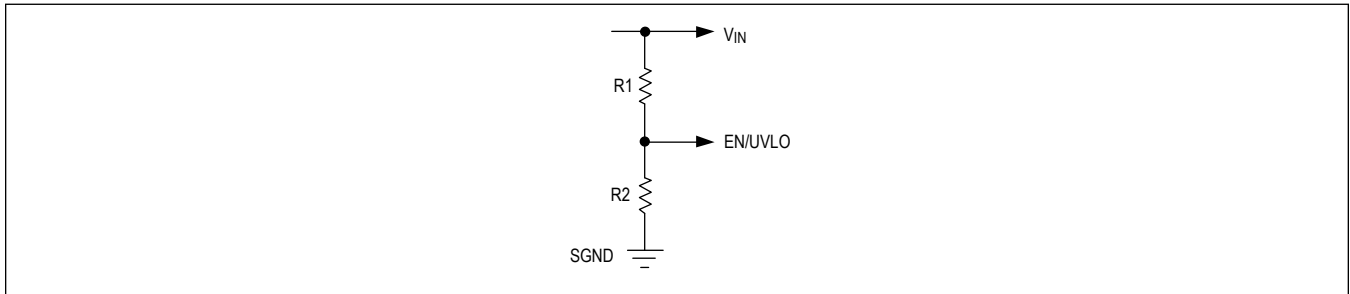

Figure 1. Setting the Input Undervoltage Lockout

### Adjusting Output Voltage

The output voltage of the buck converter can be programmed between 0.6V to 90% of  $V_{IN}$ . However, for the output voltage setting range between 0.6V and 1.8V, the minimum load should be 100 $\mu$ A for output voltage regulation.

Set the output voltage with a resistive voltage-divider connected from the output-voltage node ( $V_{OUT}$ ) to SGND (see [Figure 2](#)). Connect the center node of the divider to the FB pin. Use the following procedure to choose the resistive voltage-divider values:

Calculate resistor  $R_{TOP}$  from the output to the FB pin as follows:

$$R_{TOP} = \frac{203}{(f_C \times C_{OUT\_SEL})}$$

where:

$R_{TOP}$  is in k $\Omega$

$f_C$  = Crossover frequency in Hz

$C_{OUT\_SEL}$  = Actual capacitance of selected output capacitor at DC-bias voltage in F.

Calculate resistor  $R_{BOT}$  from the FB pin to SGND as follows:

$$R_{BOT} = \frac{R_{TOP} \times 0.6}{(V_{OUT} - 0.6)}$$

$R_{BOT}$  is in k $\Omega$ .

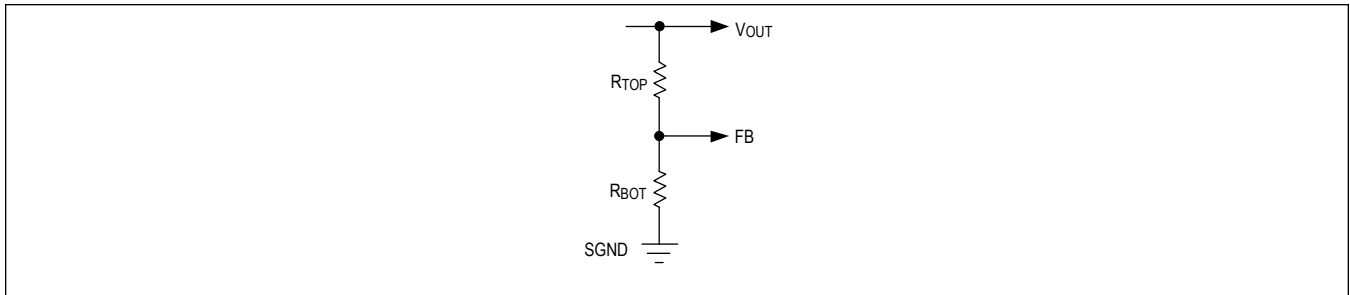

Figure 2. Setting the Output Voltage

### Power Dissipation

At a particular operating condition, the power losses that lead to temperature rise of the part are estimated as follows:

$$P_{\text{LOSS}} = \left( P_{\text{OUT}} \times \left( \frac{1}{\eta} - 1 \right) \right) - \left( I_{\text{OUT}}^2 \times R_{\text{DCR}} \right)$$

$$P_{\text{OUT}} = V_{\text{OUT}} \times I_{\text{OUT}}$$

where:

$P_{\text{OUT}}$  = Output power

$\eta$  = Efficiency of the converter

$R_{\text{DCR}}$  = DC resistance of the inductor (see the Typical Operating Characteristics for more information on efficiency at typical operating conditions).

For a typical multilayer board, the thermal performance metrics for the package are given below:

$$\theta_{\text{JA}} = 38^\circ\text{C/W}$$

$$\theta_{\text{JC}} = 4^\circ\text{C/W}$$

The junction temperature of the device can be estimated at any given maximum ambient temperature ( $T_{\text{A(MAX)}}$ ) from the following equation:

$$T_{\text{J(MAX)}} = T_{\text{A(MAX)}} + (\theta_{\text{JA}} \times P_{\text{LOSS}})$$

If the application has a thermal-management system that ensures that the exposed pad of the device is maintained at a given temperature ( $T_{\text{EP(MAX)}}$ ) by using proper heat sinks, then the junction temperature of the device can be estimated at any given maximum ambient temperature as:

$$T_{\text{J(MAX)}} = T_{\text{EP(MAX)}} + (\theta_{\text{JC}} \times P_{\text{LOSS}})$$

**Note:** Junction temperatures greater than +125°C degrade operating lifetimes.

**PCB Layout Guidelines**

All connections carrying pulsed currents must be very short and as wide as possible. The inductance of these connections must be kept to an absolute minimum due to the high  $di/dt$  of the currents. Since inductance of a current-carrying loop is proportional to the area enclosed by the loop, if the loop area is made very small, inductance is reduced. Additionally, small-current loop areas reduce radiated EMI.

A ceramic input filter capacitor should be placed close to the  $V_{IN}$  pins of the IC. This eliminates as much trace inductance effects as possible and gives the IC a cleaner voltage supply. A bypass capacitor for the  $V_{CC}$  pin also should be placed close to the pin to reduce effects of trace impedance.

When routing the circuitry around the IC, the signal ground and the power ground for switching currents must be kept separate. They should be connected together at a point where switching activity is minimum. This helps to keep the signal ground quiet. The power ground plane should be kept continuous (unbroken) as far as possible. No trace carrying high switching current should be placed directly over any ground plane discontinuity.

PCB layout also affects the thermal performance of the design. A number of thermal throughputs or vias that connect to a large plane should be provided under the exposed pad of the device for efficient heat dissipation.

For a sample layout that ensures first pass success, refer to the MAX17662 evaluation kit layout available at [www.maximintegrated.com](http://www.maximintegrated.com).

Typical Application Circuits

Typical Application Circuit—5V Output with 500kHz Switching Frequency

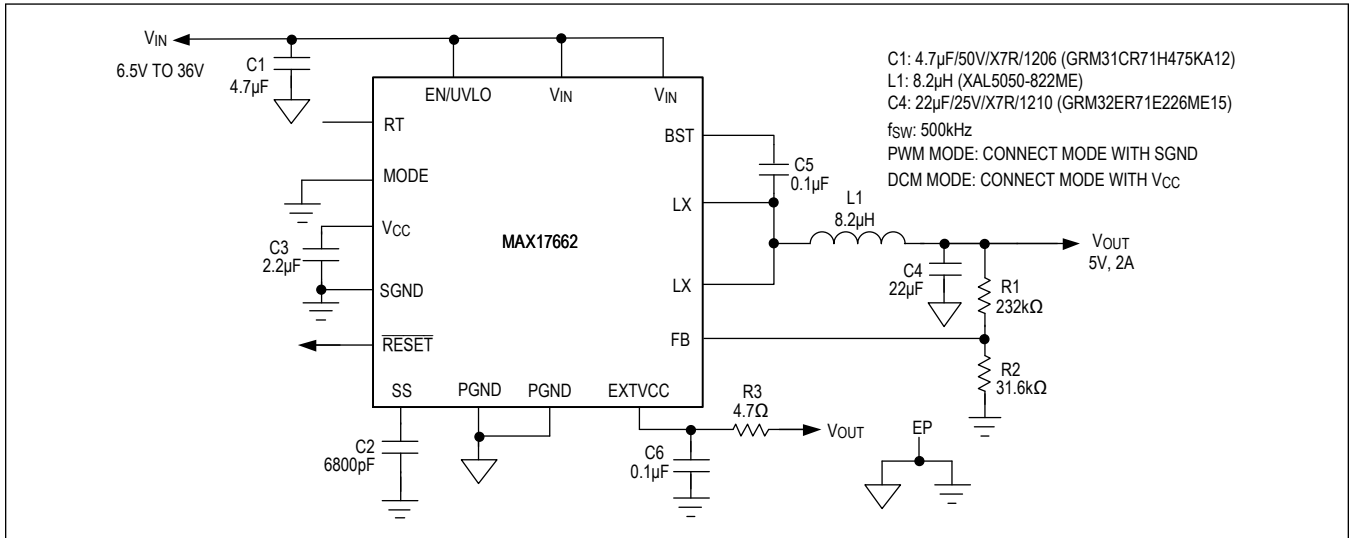

Typical Application Circuit—3.3V Output with 500kHz Switching Frequency

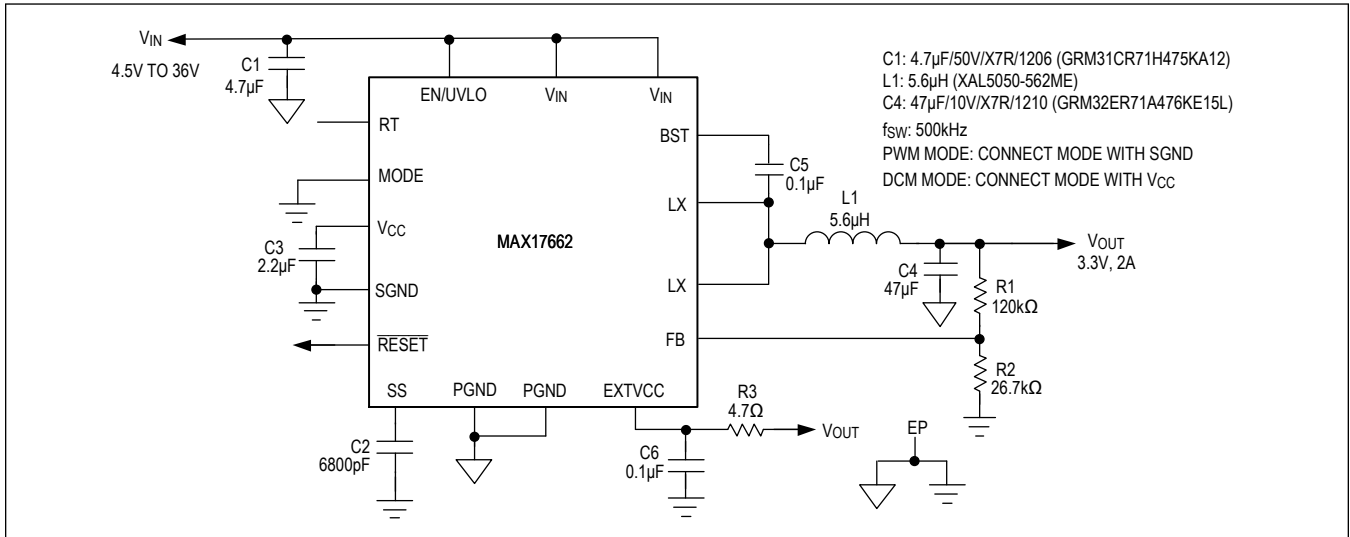

Typical Application Circuits (continued)

Typical Application Circuit—5V Output with 1MHz Switching Frequency

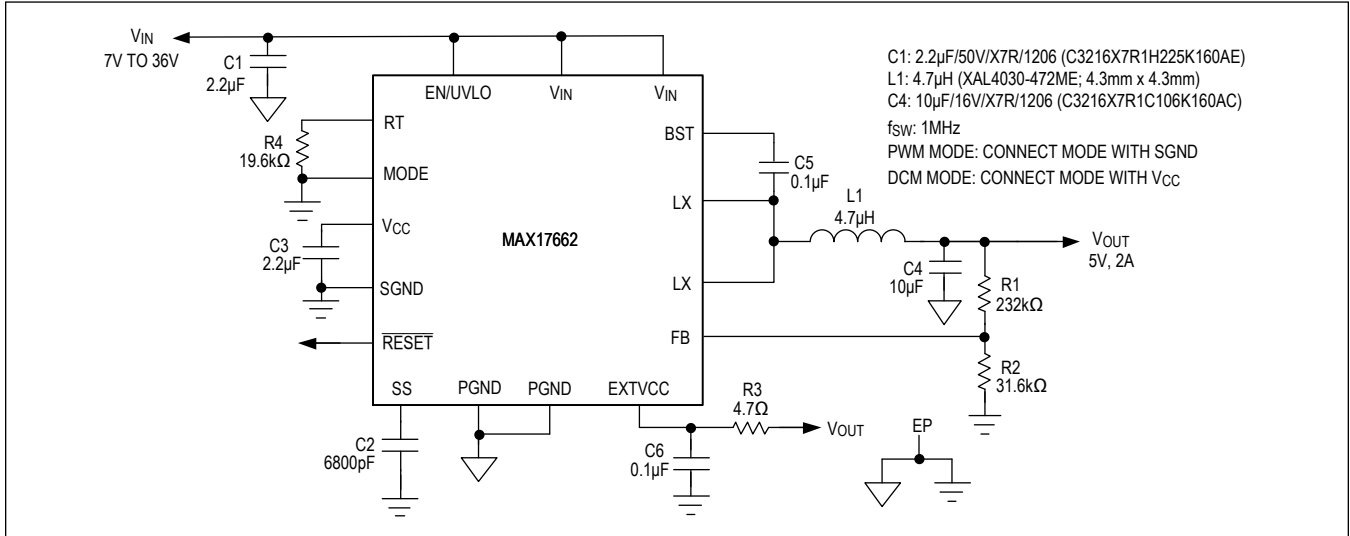

Ordering Information

PART NUMBER	MODE OF OPERATION	PIN-PACKAGE
MAX17662BATE+	PWM, DCM	16 TQFN

+ Denotes a lead(Pb)-free/RoHS-compliant package.

MAX17662

3.5V to 36V, 2A, High-Efficiency, Synchronous  
Step-Down DC-DC Converter

## Revision History

REVISION NUMBER	REVISION DATE	DESCRIPTION	PAGES CHANGED
0	7/19	Initial release	—

For pricing, delivery, and ordering information, please visit Maxim Integrated's online storefront at <https://www.maximintegrated.com/en/storefront/storefront.html>.

*Maxim Integrated cannot assume responsibility for use of any circuitry other than circuitry entirely embodied in a Maxim Integrated product. No circuit patent licenses are implied. Maxim Integrated reserves the right to change the circuitry and specifications without notice at any time. The parametric values (min and max limits) shown in the Electrical Characteristics table are guaranteed. Other parametric values quoted in this data sheet are provided for guidance.*

## X-ON Electronics

Largest Supplier of Electrical and Electronic Components

*Click to view similar products for [Switching Voltage Regulators](#) category:*

*Click to view products by [Maxim](#) manufacturer:*

Other Similar products are found below :

[FAN53610AUC33X](#) [FAN53611AUC123X](#) [FAN48610BUC33X](#) [FAN48610BUC45X](#) [FAN48617UC50X](#) [R3](#) [430464BB](#) [KE177614](#)  
[MAX809TTR](#) [NCV891234MW50R2G](#) [NCP81103MNTXG](#) [NCP81203PMNTXG](#) [NCP81208MNTXG](#) [NCP81109GMNTXG](#)  
[SCY1751FCCT1G](#) [NCP81109JMNTXG](#) [AP3409ADNTR-G1](#) [LTM8064IY](#) [LT8315EFE#TRPBF](#) [NCV1077CSTBT3G](#) [XCL207A123CR-G](#)  
[MPM54304GMN-0002](#) [MPM54304GMN-0003](#) [XDPE132G5CG000XUMA1](#) [DA9121-B0V76](#) [LTC3644IY#PBF](#) [MP8757GL-P](#)  
[MIC23356YFT-TR](#) [LD8116CGL](#) [HG2269M/TR](#) [OB2269](#) [XD3526](#) [U6215A](#) [U6215B](#) [U6620S](#) [LTC3803ES6#TR](#) [LTC3803ES6#TRM](#)  
[LTC3412IFE](#) [LT1425IS](#) [MAX25203BATJA/VY+](#) [MAX77874CEWM+](#) [XC9236D08CER-G](#) [ISL95338IRTZ](#) [MP3416GJ-P](#) [BD9S201NUX-](#)  
[CE2](#) [MP5461GC-Z](#) [MPQ4415AGQB-Z](#) [MPQ4590GS-Z](#) [MCP1642B-18IMC](#) [MCP1642D-ADJIMC](#)