



Current-Limited Switch for Two USB Ports

MAX1930

General Description

The MAX1930 current-limited 70mΩ switch with built-in fault blanking provides an accurate, preset 1.2A to 2.3A current limit, making it ideal for dual USB applications. Its low quiescent supply current (16μA) and standby current (1μA) conserve battery power in portable applications. The MAX1930 operates with inputs from 2.7V to 5.5V, making it ideal for both 3V and 5V systems.

The MAX1930 has several safety features to ensure that the USB port is protected. Built-in thermal-overload protection limits power dissipation and junction temperature. The device also has accurate internal current-limiting circuitry to protect the input supply against overload.

The MAX1930 is offered in a space-saving 8-pin SO package and operates over the extended (-40°C to +85°C) temperature range.

Features

- ◆ Pin Compatible with TPS2010–TPS2013
- ◆ Accurate Current Limit (1.2A min, 2.3A max)
- ◆ 125mΩ (max) High-Side MOSFET
- ◆ Short-Circuit and Thermal Protection
- ◆ Undervoltage Lockout
- ◆ 16μA Quiescent Supply Current
- ◆ 1μA (max) Standby Supply Current
- ◆ 2.7V to 5.5V Supply Range
- ◆ UL Recognized: UL# E211395

Applications

Notebook Computers

USB Ports and Hubs

Docking Stations

Ordering Information

PART	TEMP RANGE	PIN-PACKAGE
MAX1930ESA	-40°C to +85°C	8 SO

Pin Configuration

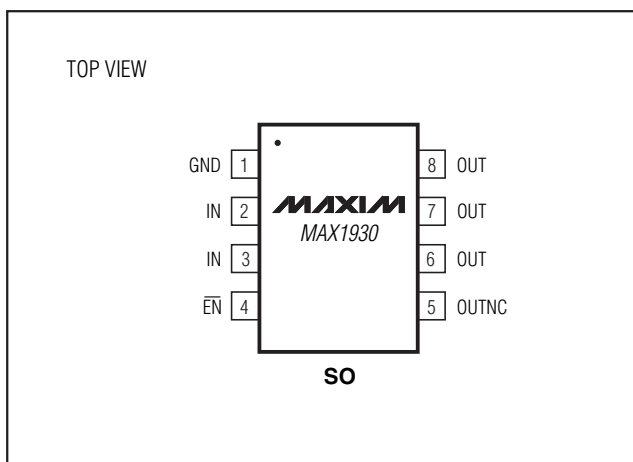

Typical Operating Circuit

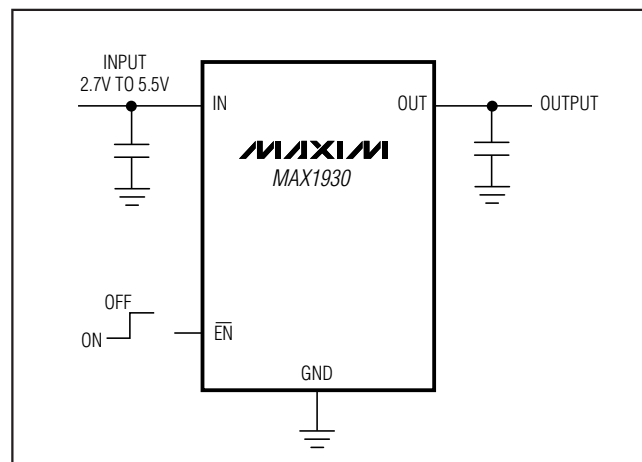

Current-Limited Switch for Two USB Ports

ABSOLUTE MAXIMUM RATINGS

IN, $\overline{\text{EN}}$ to GND-0.3V to +6V
 OUT to GND-0.3V to ($V_{\text{IN}} + 0.3\text{V}$)
 Maximum Switch Current.....2.3A (internally limited)
 OUT Short Circuit to GNDContinuous

Continuous Power Dissipation ($T_A = +70^\circ\text{C}$)
 8-Pin SO (derate 5.88mW/ $^\circ\text{C}$ above $+70^\circ\text{C}$).....471mW
 Operating Temperature Range (extended)..... -40°C to $+85^\circ\text{C}$
 Storage Temperature Range -65°C to $+150^\circ\text{C}$
 Lead Temperature (soldering, 10s) $+300^\circ\text{C}$

Stresses beyond those listed under "Absolute Maximum Ratings" may cause permanent damage to the device. These are stress ratings only, and functional operation of the device at these or any other conditions beyond those indicated in the operational sections of the specifications is not implied. Exposure to absolute maximum rating conditions for extended periods may affect device reliability.

ELECTRICAL CHARACTERISTICS

($V_{\text{IN}} = 5\text{V}$, $T_A = 0^\circ\text{C}$ to $+85^\circ\text{C}$, unless otherwise noted. Typical values are at $T_A = +25^\circ\text{C}$.)

PARAMETER	SYMBOL	CONDITIONS	MIN	TYP	MAX	UNITS	
OPERATING CONDITION							
Input Voltage	V_{IN}		2.7		5.5	V	
POWER SWITCH							
Switch Static Drain-Source On-Resistance	$R_{\text{DS(ON)}}$	$T_A = +25^\circ\text{C}$	$V_{\text{IN}} = 4.4\text{V}$ to 5.5V		70	100	m Ω
		$T_A = 0^\circ\text{C}$ to $+85^\circ\text{C}$	$V_{\text{IN}} = 4.4\text{V}$ to 5.5V			125	
			$V_{\text{IN}} = 3\text{V}$		72	150	
Switch Turn-On Time	t_{ON}	$I_{\text{LOAD}} = 400\text{mA}$		80	200	μs	
Switch Turn-Off Time	t_{OFF}	$I_{\text{LOAD}} = 400\text{mA}$	3	6	20	μs	
ENABLE INPUT ($\overline{\text{EN}}$)							
$\overline{\text{EN}}$ High-Level Input Voltage	V_{IH}	$V_{\text{IN}} = 2.7\text{V}$ to 3.6V	2.0			V	
		$V_{\text{IN}} = 3.7\text{V}$ to 5.5V	2.4				
$\overline{\text{EN}}$ Low-Level Input Voltage	V_{IL}	$V_{\text{IN}} = 2.7\text{V}$ to 5.5V			0.8	V	
$\overline{\text{EN}}$ Input Current		$V_{\overline{\text{EN}}} = V_{\text{IN}}$ or GND	-1		+1	μA	
Startup Time		$V_{\text{IN}} = 5\text{V}$, $C_{\text{OUT}} = 150\mu\text{F}$ from $\overline{\text{EN}}$ driven low to 50% full V_{OUT}		1		ms	
CURRENT LIMIT							
Overload Output Current	I_{LIMIT}	Force V_{OUT} to 4.5V	1.2	1.75	2.3	A	
Short-Circuit Output Current	I_{SC}	OUT shorted to GND		1	1.5	A	
SUPPLY CURRENT							
Supply Current, Low-Level Input		$V_{\overline{\text{EN}}} = V_{\text{IN}} = V_{\text{OUT}} = 5.5\text{V}$		0.002	1	μA	
Supply Current, High-Level Input	I_{Q}	$V_{\overline{\text{EN}}} = 0$, $I_{\text{OUT}} = 0$	Timer not running	16	25	μA	
			Timer running	35			
Supply Leakage Current		$V_{\overline{\text{EN}}} = V_{\text{IN}} = 5.5\text{V}$, $V_{\text{OUT}} = 0$	$T_A = +25^\circ\text{C}$	0.01	2	μA	
			$T_A = 0^\circ\text{C}$ to $+85^\circ\text{C}$	15			
UNDERVOLTAGE LOCKOUT							
Undervoltage Lockout	UVLO	Rising edge, 100mV hysteresis	2.0	2.4	2.6	V	
THERMAL SHUTDOWN							
Thermal-Shutdown Threshold				165		$^\circ\text{C}$	

Current-Limited Switch for Two USB Ports

MAX1930

ELECTRICAL CHARACTERISTICS

($V_{IN} = 5V$, $T_A = -40^{\circ}C$ to $+85^{\circ}C$, unless otherwise noted.) (Note 1)

PARAMETER	SYMBOL	CONDITIONS	MIN	TYP	MAX	UNITS
OPERATING CONDITION						
Input Voltage	V_{IN}		3.0		5.5	V
POWER SWITCH						
Switch Static Drain-Source On-Resistance	$R_{DS(ON)}$	$V_{IN} = 4.4V$ to $5.5V$			125	m Ω
		$V_{IN} = 3V$			150	
Switch Turn-On Time	t_{ON}	$I_{LOAD} = 400mA$			200	μs
Switch Turn-Off Time	t_{OFF}	$I_{LOAD} = 400mA$	1		20	μs
ENABLE INPUT (\overline{EN})						
\overline{EN} High-Level Input Voltage	V_{IH}	$V_{IN} = 3V$ to $3.6V$	2.0			V
		$V_{IN} = 3.7V$ to $5.5V$	2.4			
\overline{EN} Low-Level Input Voltage	V_{IL}	$V_{IN} = 3V$ to $5.5V$			0.8	V
\overline{EN} Input Current		$V_{\overline{EN}} = V_{IN}$ or GND	-1		+1	μA
CURRENT LIMIT						
Overload Output Current	I_{LIMIT}	Force V_{OUT} to 4.5V	1.2		2.3	A
Short-Circuit Output Current	I_{SC}	OUT shorted to GND			1.5	A
SUPPLY CURRENT						
Supply Current, Low-Level Input		$V_{\overline{EN}} = V_{IN} = V_{OUT} = 5.5V$			2	μA
Supply Current, High-Level Input	I_Q	$V_{\overline{EN}} = GND$, $I_{OUT} = 0$, timer not running			25	μA
Supply Leakage Current		$V_{\overline{EN}} = V_{IN} = 5.5V$, $V_{OUT} = GND$			15	μA
UNDERVOLTAGE LOCKOUT						
Undervoltage Lockout	UVLO	Rising edge, 100mV hysteresis	2.0		2.9	V

Note 1: Specifications to $-40^{\circ}C$ are guaranteed by design, not production tested.

Typical Operating Characteristics

(Circuit of Figure 2, $V_{IN} = 5V$, $T_A = +25^{\circ}C$, unless otherwise noted.)

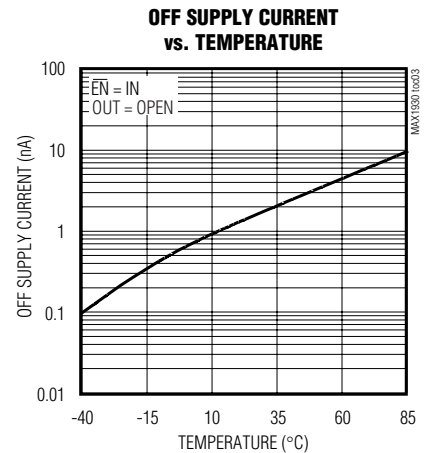
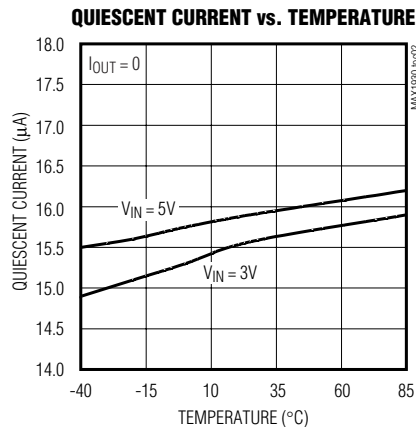
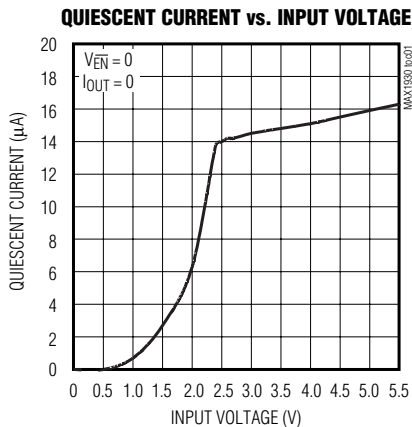

Current-Limited Switch for Two USB Ports

Typical Operating Characteristics (continued)

(Circuit of Figure 2, $V_{IN} = 5V$, $T_A = +25^\circ C$, unless otherwise noted.)

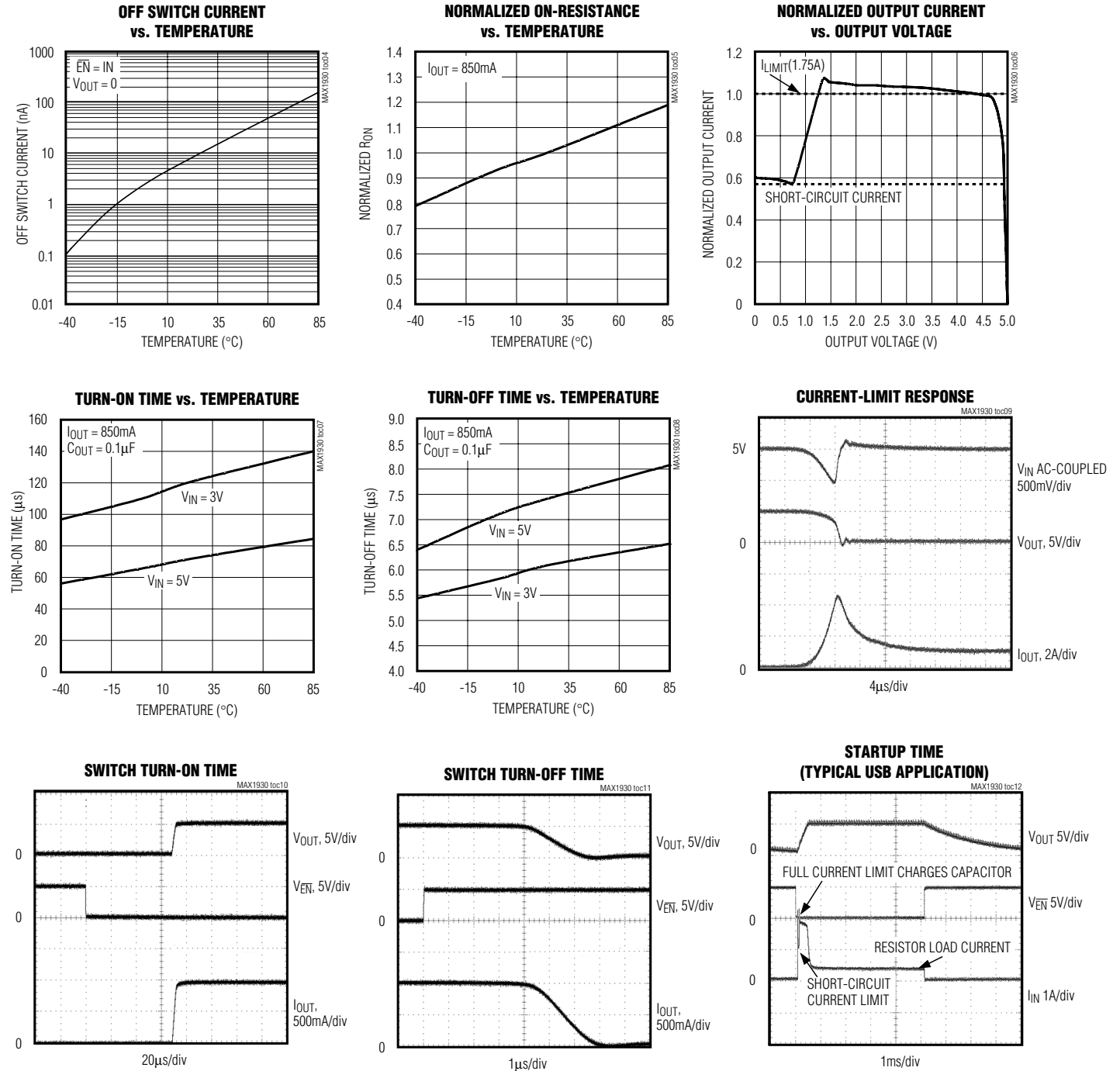

Current-Limited Switch for Two USB Ports

Pin Description

PIN	NAME	FUNCTION
1	GND	Ground
2, 3	IN	Input. P-channel MOSFET source—connect all IN pins together and bypass with a 1μF capacitor to ground.
4	$\overline{\text{EN}}$	Active-Low Switch Enable Input. A logic low turns on the switch.
5	OUTNC	No Connection. This pin is not internally connected and can be connected to OUT.
6, 7, 8	OUT	Switch Output. P-channel MOSFET drain—connect all OUT pins together and bypass with a 0.1μF capacitor to ground.

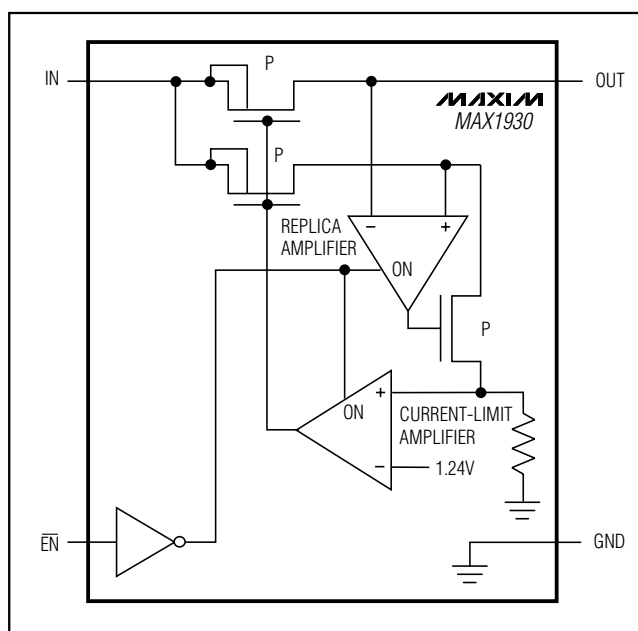

Figure 1. Functional Diagram

Detailed Description

The MAX1930 P-channel MOSFET power switch limits output current to 1.2A (min) and 2.3A (max). When the output current increases beyond the current limit (I_{LIMIT}), the current also increases through the replica switch ($I_{OUT} / 13,000$). The current-limit error amplifier compares the voltage to the internal 1.24V reference and regulates the current back to the I_{LIMIT} (Figure 1).

These switches are not bidirectional. As a result, the input voltage must be higher than the output voltage.

Continuous Short-Circuit Protection

The MAX1930 is a short-circuit protected switch. In the event of an output short-circuit condition, the current through the switch is foldback-current-limited to 1A continuous.

Thermal Shutdown

The MAX1930 has a thermal shutdown feature. The switch turns off when the junction temperature exceeds +165°C. When the MAX1930 cools 20°C, the switch turns back on. If the fault short-circuit condition is not removed, the switch cycles on and off, resulting in a pulsed output.

Applications Information

Input Capacitor

To limit the input voltage drop during momentary output short-circuit conditions, connect a capacitor from IN to GND. A 1μF ceramic capacitor is adequate for most applications; however, higher capacitor values further reduce the voltage drop at the input (Figure 2).

Output Capacitor

Connect a 0.1μF capacitor from OUT to GND. This capacitor helps to prevent inductive parasitics from pulling OUT negative during turn-off.

Layout and Thermal Dissipation

It is important to optimize the switch response time to output short-circuit conditions by keeping all traces as short as possible to reduce the effect of undesirable parasitic inductance. Place input and output capacitors as close as possible to the device (no more than 5mm away). All IN and OUT pins must be connected with short traces to the power bus. Wide power-bus planes provide superior heat dissipation through the MAX1930's IN and OUT pins.

Under normal operating conditions, the package can dissipate and channel heat away. Calculate the maximum power dissipation as follows:

$$P = (I_{LIMIT})^2 \times R_{ON}$$

where I_{LIMIT} is the preset current limit (2.3A max) and R_{ON} is the on-resistance of the switch (125mΩ max).

When the output is short circuited, foldback-current-limiting activates and the voltage drop across the switch equals the input supply voltage. The power dissipated across the switch increases, as does the die tempera-

Current-Limited Switch for Two USB Ports

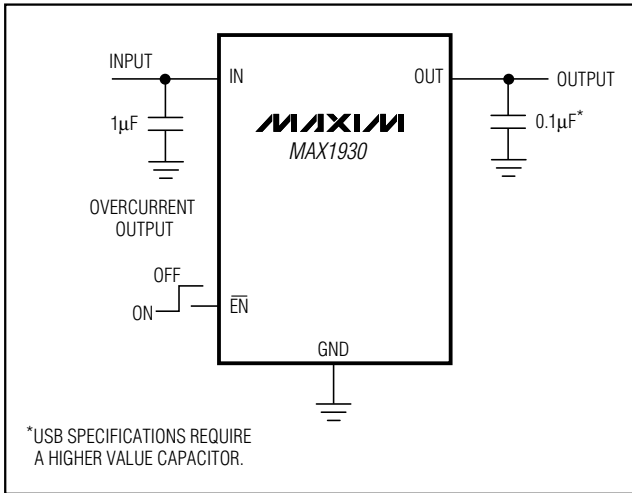

Figure 2. Typical Application Circuit

ture. If the fault condition is not removed, the thermal-overload protection circuitry activates (see the *Thermal Shutdown* section). Wide power-bus planes connected to IN and OUT and a ground plane in contact with the device help dissipate additional heat.

Driving Inductive Loads

A wide variety of devices (mice, keyboards, cameras, and printers) can load the USB port. These devices commonly connect to the port with cables, which can add an inductive component to the load. This inductance causes the output voltage at the USB port to ring during a load step. The MAX1930 is capable of driving inductive loads, but avoid exceeding the device's absolute maximum ratings. Usually the load inductance is relatively small, and the MAX1930's input includes a substantial bulk capacitance from an upstream regulator, as well as local bypass capacitors, limiting overshoot. If severe ringing occurs due to large load inductance, clamp the MAX1930 output below 6V and above -0.3V.

Chip Information

TRANSISTOR COUNT: 715

PROCESS: BiCMOS

Current-Limited Switch for Two USB Ports

Package Information

(The package drawing(s) in this data sheet may not reflect the most current specifications. For the latest package outline information, go to www.maxim-ic.com/packages.)

MAX1930

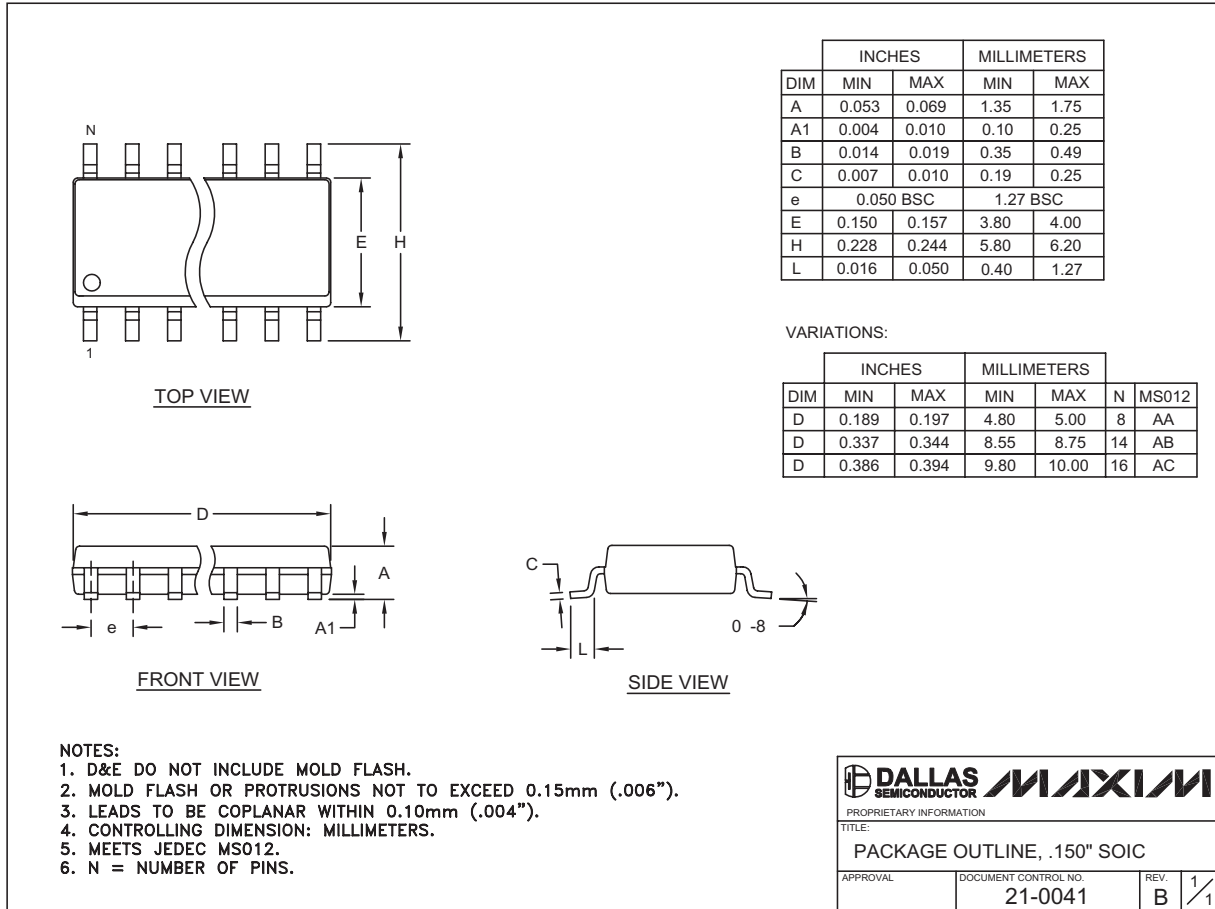

Maxim cannot assume responsibility for use of any circuitry other than circuitry entirely embodied in a Maxim product. No circuit patent licenses are implied. Maxim reserves the right to change the circuitry and specifications without notice at any time.

Maxim Integrated Products, 120 San Gabriel Drive, Sunnyvale, CA 94086 408-737-7600 _____ **7**

X-ON Electronics

Largest Supplier of Electrical and Electronic Components

Click to view similar products for [Power Switch ICs - Power Distribution category](#):

Click to view products by [Maxim manufacturer](#):

Other Similar products are found below :

[TCK111G,LF\(S\)](#) [FPF1018](#) [DS1222](#) [TCK2065G,LF](#) [SZNCP3712ASNT3G](#) [MIC2033-05BYMT-T5](#) [MIC2033-12AYMT-T5](#) [MIC2033-05BYM6-T5](#) [SLG5NT1437VTR](#) [SZNCP3712ASNT1G](#) [DML1008LDS-7](#) [KTS1670EDA-TR](#) [KTS1640QGDV-TR](#) [KTS1641QGDV-TR](#) [U6513A](#) [MIC2012YM-TR](#) [MP5095GJ-P](#) [TPS2021IDRQ1](#) [TPS2104DBVR](#) [TPS22958NDGKR](#) [MIC2098-1YMT-TR](#) [MIC94062YMT TR](#) [MP6231DN-LF](#) [MIC2015-1.2YM6 TR](#) [MIC2075-2YM](#) [MIC94068YML-TR](#) [SIP32461DB-T2-GE1](#) [NCP335FCT2G](#) [TCK105G,LF\(S\)](#) [AP2411S-13](#) [AP2151DSG-13](#) [AP2172MPG-13](#) [MIC94094YC6-TR](#) [MIC94093YC6-TR](#) [MIC94064YC6-TR](#) [MIC94061YMT-TR](#) [MIC2505-1YM](#) [MIC94085YFT-TR](#) [MIC94042YFL-TR](#) [MIC2005-1.2YM6-TR](#) [NCP333FCT2G](#) [NCP331SNT1G](#) [TPS2092DR](#) [TPS2063DR](#) [MIC2008YML-TR](#) [MIC94084YFT-TR](#) [MIC2040-1YMM](#) [DIO1280WL12](#) [AP22814ASN-7](#) [MIC2043-2YTS](#)