



# Current-Limited Switch for Single USB Port

MAX1931

## General Description

The MAX1931 is a current-limited, 60mΩ switch with built-in fault blanking. Its accurate preset current limit of 0.64A to 1.06A makes it ideally suited for USB applications. The device's low quiescent supply current (14μA) and shutdown current (1μA) conserve battery power in portable applications. The MAX1931 operates with inputs from 2.7V to 5.5V, making it ideal for both 3V and 5V systems.

A fault signal notifies the microprocessor that the internal current limit has been reached. A 10ms fault-blanking feature allows momentary faults (such as those caused when hot-swapping into a capacitive load) to be ignored, thus preventing false alarms to the host system. This fault blanking also prevents a fault signal from being issued when the device is powering up.

In the MAX1931, an output overcurrent condition causes the switch to current limit at 0.64A to 1.06A and  $\overline{\text{FAULT}}$  to go low after the 10ms blanking period. When the overcurrent condition is removed,  $\overline{\text{FAULT}}$  returns to its high-impedance state.

The MAX1931 has several safety features to ensure that the USB port is protected. Built-in thermal overload protection limits power dissipation and junction temperatures. The device has an accurate internal current-limiting circuitry to protect the input supply against overload. The MAX1931 is available in a space-saving 10-pin μMAX package.

## Applications

- USB Ports and Hubs
- Notebook Computers
- Portable Equipment
- Docking Stations
- Hot Plug-In Power Supplies
- Battery-Charger Circuits

## Features

- ◆ 0.5A Guaranteed Output Current
- ◆ Guaranteed 0.75A Short-Circuit Protection
- ◆ 10ms Internal Fault-Blanking Timeout
- ◆ No Fault Signal During Power-Up
- ◆ Thermal Shutdown Protection
- ◆ 2.7V to 5.5V Supply Range
- ◆ 14μA Supply Current
- ◆ Small 10-Pin μMAX Package

## Ordering Information

PART	TEMP RANGE	PIN-PACKAGE
MAX1931EUB	-40°C to +85°C	10μMAX

## Pin Configuration

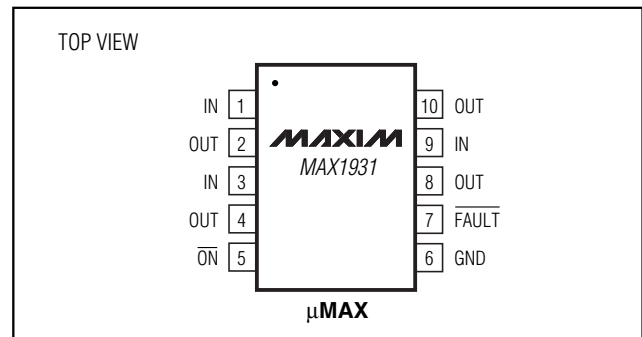

## Typical Operating Circuit

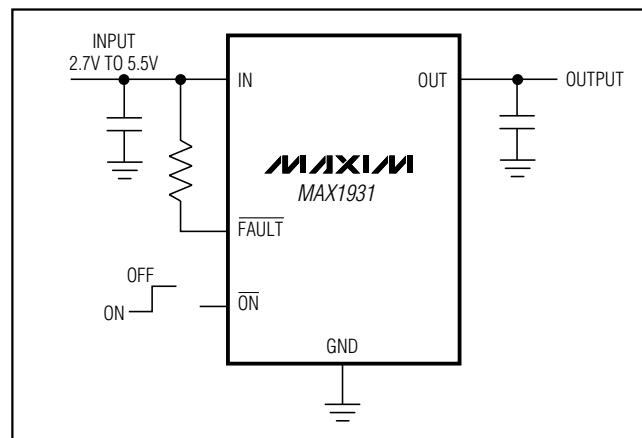

# Current-Limited Switch for Single USB Port

## ABSOLUTE MAXIMUM RATINGS

IN, $\overline{\text{ON}}$ (ON), $\overline{\text{FAULT}}$ to GND .....	-0.3V to +6V	Operating Temperature Range .....	-40°C to +85°C
OUT to GND .....	-0.3V to ( $V_{\text{IN}} + 0.3\text{V}$ )	Storage Temperature Range .....	-65°C to +150°C
Maximum Continuous Switch Current .....	1.2A (internally limited)	Lead Temperature (soldering, 10s) .....	+300°C
OUT Short Circuit to GND .....	Continuous		
Continuous Power Dissipation ( $T_{\text{A}} = +70^{\circ}\text{C}$ )			
10-Pin $\mu\text{MAX}$ (derate 5.6mW/°C above +70°C) .....	444mW		

Stresses beyond those listed under "Absolute Maximum Ratings" may cause permanent damage to the device. These are stress ratings only, and functional operation of the device at these or any other conditions beyond those indicated in the operational sections of the specifications is not implied. Exposure to absolute maximum rating conditions for extended periods may affect device reliability.

## ELECTRICAL CHARACTERISTICS

( $V_{\text{IN}} = 5\text{V}$ ,  $T_{\text{A}} = 0^{\circ}\text{C}$  to  $+85^{\circ}\text{C}$ , unless otherwise noted. Typical values are at  $T_{\text{A}} = +25^{\circ}\text{C}$ .)

PARAMETER	SYMBOL	CONDITIONS		MIN	TYP	MAX	UNITS	
Operating Voltage	$V_{\text{IN}}$			2.7		5.5	V	
Quiescent Current	$I_{\text{Q}}$	$V_{\overline{\text{ON}}} = \text{GND}$ , $I_{\text{OUT}} = 0$	Timer not running		14	35	$\mu\text{A}$	
			Timer running		35			
Off Supply Current		$V_{\overline{\text{ON}}} = V_{\text{IN}} = V_{\text{OUT}} = 5.5\text{V}$			0.001	1	$\mu\text{A}$	
Undervoltage Lockout	UVLO	Rising edge, 100mV hysteresis		2.0		2.6	V	
Off Switch Leakage		$V_{\overline{\text{ON}}} = V_{\text{IN}}$ $V_{\text{IN}} = 5.5\text{V}$ , $V_{\text{OUT}} = \text{GND}$	$T_{\text{A}} = +25^{\circ}\text{C}$		0.01	4	$\mu\text{A}$	
			$T_{\text{A}} = 0^{\circ}\text{C}$ to $+85^{\circ}\text{C}$					20
On-Resistance	$R_{\text{ON}}$	$T_{\text{A}} = +25^{\circ}\text{C}$ $T_{\text{A}} = 0^{\circ}\text{C}$ to $+85^{\circ}\text{C}$	$V_{\text{IN}} = 4.4\text{V}$ to $5.5\text{V}$		60	110	$\text{m}\Omega$	
			$V_{\text{IN}} = 4.4\text{V}$ to $5.5\text{V}$					150
			$V_{\text{IN}} = 3\text{V}$					72
Current Limit	$I_{\text{LIMIT}}$	$V_{\text{OUT}} = 4.5\text{V}$		640	850	1060	$\text{mA}$	
Continuous Short-Circuit Current Limit	$I_{\text{SC}}$	OUT shorted to GND			500	700	$\text{mA}$	
$\overline{\text{ON}}$ Input Logic Low Voltage	$V_{\text{IL}}$	$V_{\text{IN}} = 2.7\text{V}$ to $5.5\text{V}$				0.8	V	
$\overline{\text{ON}}$ Input Logic High Voltage	$V_{\text{IH}}$	$V_{\text{IN}} = 2.7\text{V}$ to $3.6\text{V}$		2			V	
		$V_{\text{IN}} = 3.7\text{V}$ to $5.5\text{V}$		2.4				
$\overline{\text{ON}}$ Input Leakage		$V_{\overline{\text{ON}}} = V_{\text{IN}}$ or GND				$\pm 1$	$\mu\text{A}$	
$\overline{\text{FAULT}}$ Output Logic Low Voltage	$V_{\text{OL}}$	$I_{\text{SINK}} = 1\text{mA}$ , $V_{\text{IN}} = 3\text{V}$				0.4	V	
$\overline{\text{FAULT}}$ Output High Leakage Current		$V_{\text{IN}} = V_{\overline{\text{FAULT}}} = 5.5\text{V}$				1	$\mu\text{A}$	
Fault-Blanking Timeout Period	$t_{\text{FB}}$	From overcurrent condition to $\overline{\text{FAULT}}$ assertion		6	10	13	ms	
Startup Time		$V_{\text{IN}} = 5\text{V}$ , $C_{\text{OUT}} = 150\mu\text{F}$ , $R_{\text{L}} = 15\Omega$ , from $\overline{\text{ON}}$ driven low to 50% full $V_{\text{OUT}}$			1		ms	
Switch Turn-On Time	$t_{\text{ON}}$	$I_{\text{LOAD}} = 400\text{mA}$			80	200	$\mu\text{s}$	
Switch Turn-Off Time	$t_{\text{OFF}}$	$I_{\text{LOAD}} = 400\text{mA}$		3	6	20	$\mu\text{s}$	
Thermal Shutdown Threshold					165		$^{\circ}\text{C}$	

# Current-Limited Switch for Single USB Port

MAX1931

## ELECTRICAL CHARACTERISTICS

( $V_{IN} = 5V$ ,  $T_A = -40^{\circ}C$  to  $+85^{\circ}C$ , unless otherwise noted.) (Note 1)

PARAMETER	SYMBOL	CONDITIONS	MIN	TYP	MAX	UNITS
Operating Voltage	$V_{IN}$		3		5.5	V
Quiescent Current	$I_Q$	$\overline{ON} = GND$ , $I_{OUT} = 0$ , timer not running			35	$\mu A$
Off Supply Current		$\overline{ON} = V_{IN} = V_{OUT} = 5.5V$			2	$\mu A$
Undervoltage Lockout	UVLO	Rising edge, 100mV hysteresis	2.0		2.9	V
Off Switch Leakage		$\overline{ON} = V_{IN} = 5.5V$ , $V_{OUT} = GND$			20	$\mu A$
On-Resistance	$R_{ON}$	$V_{IN} = 4.4V$ to $5.5V$			150	$m\Omega$
		$V_{IN} = 3V$			180	
Current Limit	$I_{LIMIT}$	$V_{OUT} = 4.5V$	600		1100	mA
Continuous Short-Circuit Current Limit		OUT shorted to GND			750	mA
$\overline{ON}$ Input Logic Low Voltage	$V_{IL}$	$V_{IN} = 3V$ to $5.5V$			0.8	V
$\overline{ON}$ Input Logic High Voltage	$V_{IH}$	$V_{IN} = 3V$ to $3.6V$	2			V
		$V_{IN} = 3.7V$ to $5.5V$	2.4			
$\overline{ON}$ Input Leakage		$\overline{ON} = V_{IN}$ or GND			$\pm 1$	$\mu A$
$\overline{FAULT}$ Output Logic Low Voltage	$V_{OL}$	$I_{SINK} = 1mA$ , $V_{IN} = 3V$			0.4	V
$\overline{FAULT}$ Output High Leakage Current		$V_{IN} = V_{\overline{FAULT}} = 5.5V$			1	$\mu A$
Fault-Blanking Timeout Period	$t_{FB}$	From overcurrent condition to $\overline{FAULT}$ assertion	6		14	ms
Switch Turn-On Time	$t_{ON}$	$I_{LOAD} = 400mA$			200	$\mu s$
Switch Turn-Off Time	$t_{OFF}$	$I_{LOAD} = 400mA$	1		20	$\mu s$

**Note 1:** Specifications to  $-40^{\circ}C$  are guaranteed by design, not production tested.

# Current-Limited Switch for Single USB Port

## Typical Operating Characteristics

( $V_{IN} = 5V$ ,  $T_A = +25^\circ C$ , unless otherwise noted.)

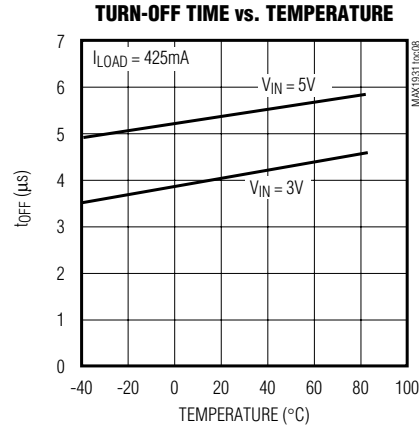
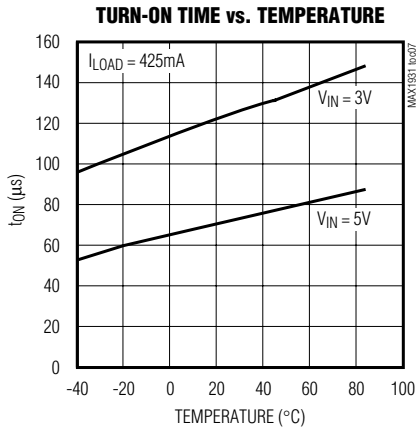
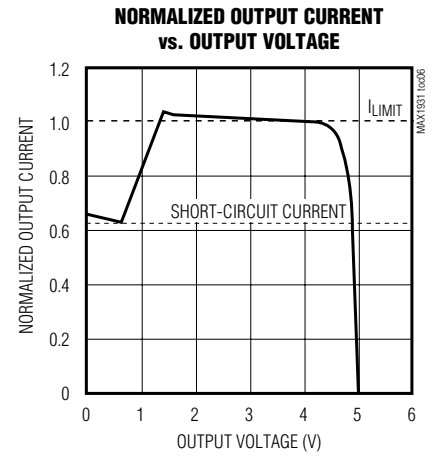
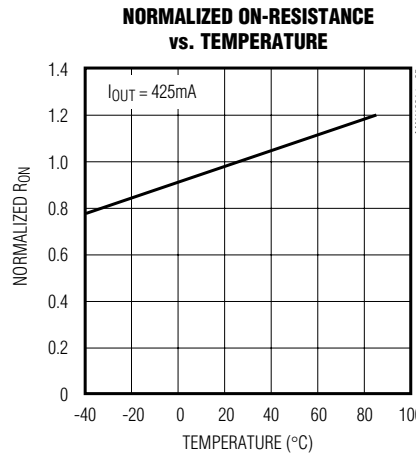
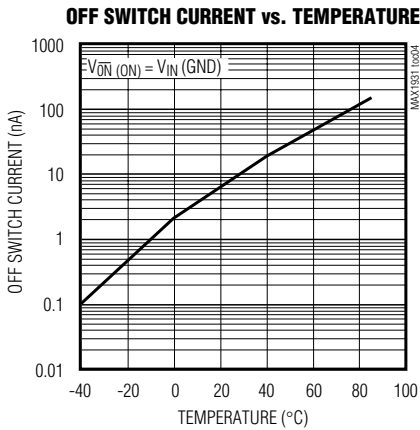
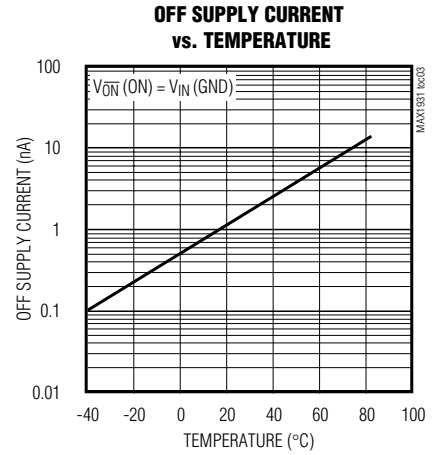
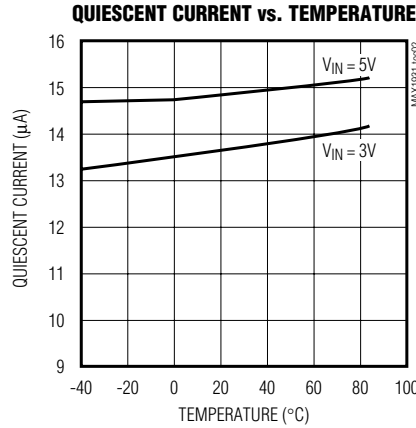
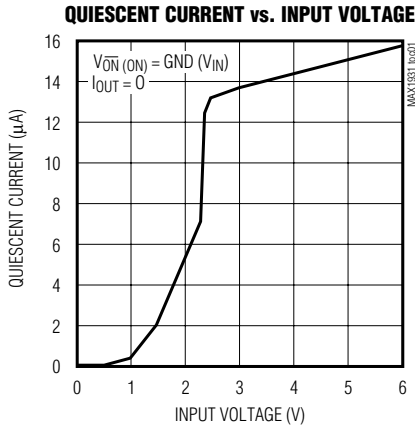

# Current-Limited Switch for Single USB Port

MAX1931

## Typical Operating Characteristics (continued)

( $V_{IN} = 5V$ ,  $T_A = +25^\circ C$ , unless otherwise noted.)

**FAULT-BLANKING TIMEOUT vs. TEMPERATURE**

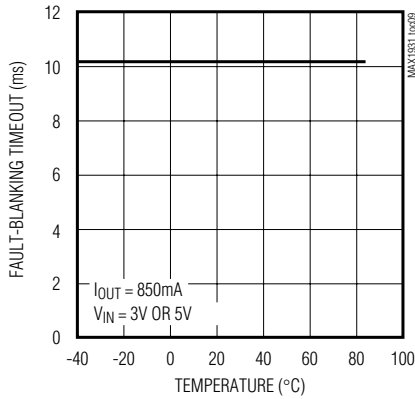

**CURRENT-LIMIT AND FAULT RESPONSE**

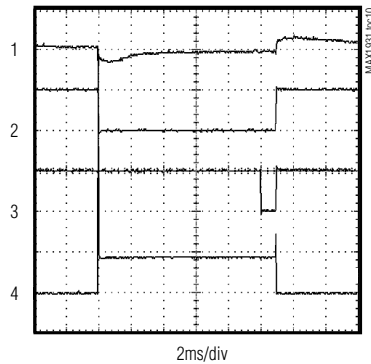

CH1 =  $V_{IN}$ , 200mV/div, AC-COUPLED; CH2 =  $V_{OUT}$ , 5V/div; CH3 =  $V_{FAULT}$ , 5V/div; CH4 =  $I_{OUT}$ , 500mA/div

**CURRENT-LIMIT RESPONSE**

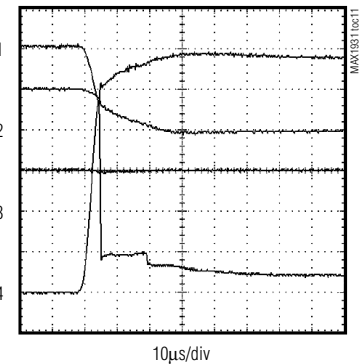

CH1 =  $V_{IN}$ , 200mV/div, AC-COUPLED; CH2 =  $V_{OUT}$ , 5V/div; CH3 =  $V_{FAULT}$ , 5V/div; CH4 =  $I_{OUT}$ , 1A/div

**SWITCH TURN-ON TIME**

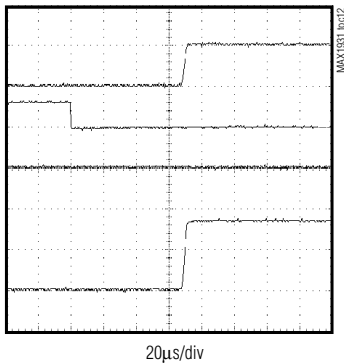

CH1 =  $V_{OUT}$ , 5V/div; CH2 =  $V_{ON}$ , 5V/div; CH3 =  $V_{FAULT}$ , 5V/div; CH4 =  $I_{OUT}$ , 200mA/div

**SWITCH TURN-OFF TIME**

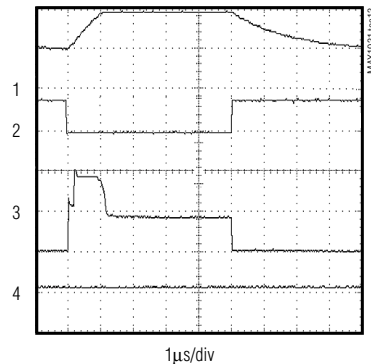

CH1 =  $V_{OUT}$ , 5V/div; CH2 =  $V_{ON}$ , 5V/div; CH3 =  $V_{FAULT}$ , 5V/div; CH4 =  $I_{OUT}$ , 200mA/div

**STARTUP TIME (TYPICAL USB APPLICATION)**

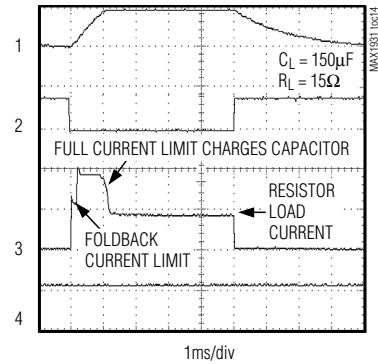

CH1 =  $V_{OUT}$ , 5V/div; CH2 =  $V_{ON}$ , 5V/div; CH3 =  $I_{OUT}$ , 500mA/div; CH4 =  $V_{FAULT}$ , 5V/div

# Current-Limited Switch for Single USB Port

## Pin Description

PIN	NAME	FUNCTION
1, 3, 9	IN	Input. P-channel MOSFET source. Connect all IN pins together and bypass with a 1 $\mu$ F ceramic capacitor to ground.
2, 4, 8, 10	OUT	Switch Output. P-channel MOSFET drain. Connect all OUT pins together and bypass with a 0.1 $\mu$ F capacitor to ground.
5	$\overline{\text{ON}}$	Active-Low Switch On Input. A logic low turns the switch on.
6	GND	Ground
7	$\overline{\text{FAULT}}$	Fault-Indicator Output. This open-drain output goes low when the device is in thermal shut-down, undervoltage lockout, or on a sustained (>10ms) current-limit condition.

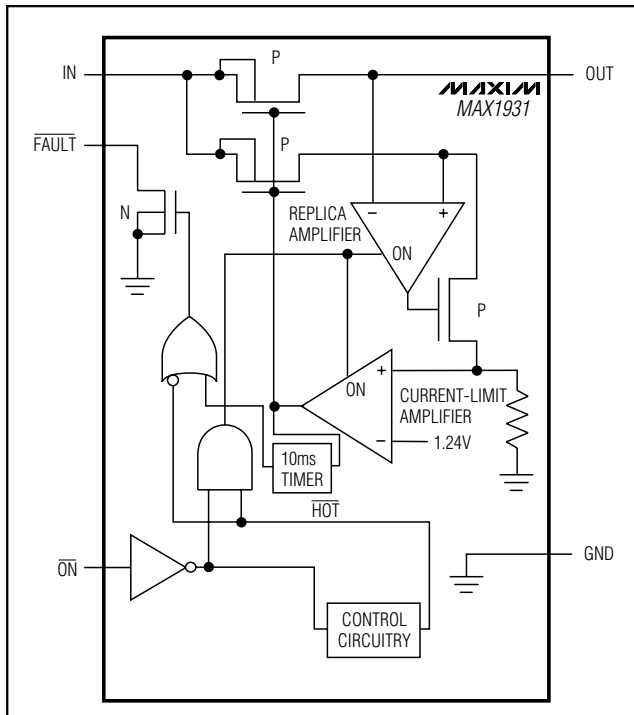

Figure 1. Functional Diagram

## Detailed Description

The MAX1931 P-channel MOSFET power switch limits output current to 0.64A (min) to 1.06A (max). When the output current is increased beyond the current limit (LIMIT), the current also increases through the replica switch ( $I_{OUT} / 6500$ ). The current-limit error amplifier compares the voltage to the internal 1.24V reference and regulates the current back to the LIMIT.

This switch is not bidirectional; therefore, the input voltage must be higher than the output voltage.

## Continuous Short-Circuit Protection

The MAX1931 is a foldback short-circuit-protected switch. In the event of an output short-circuit or current-overload condition, the current through the switch is foldback-current-limited to 500mA continuous.

## Thermal Shutdown

The MAX1931 features thermal shutdown. The switch turns off and the  $\overline{\text{FAULT}}$  output goes low immediately (no fault blanking) when the junction temperature exceeds +165°C. When the MAX1931 cools 20°C, the switch turns back on. If the fault short-circuit condition is not removed, the switch cycles on and off, resulting in a pulsed output.

## $\overline{\text{FAULT}}$ Indicator

The MAX1931 provides a fault output ( $\overline{\text{FAULT}}$ ). A 100k $\Omega$  pullup resistor from  $\overline{\text{FAULT}}$  to IN provides a logic control signal. This open-drain output goes low when any of the following conditions occur:

- The input voltage is below the undervoltage lockout (UVLO) threshold.
- The die temperature exceeds the thermal shutdown temperature limit of +165°C.
- The device is in current limit and the 10ms fault-blanking period is exceeded.

## Fault Blanking

The MAX1931 features 10ms fault blanking. Fault blanking allows current-limit faults, including momentary short-circuit faults that occur when hot-swapping a capacitive load, and also ensures that no fault is issued during power-up. When a load transient causes the device to enter current limit, an internal counter starts. If the load fault persists beyond the 10ms fault-blanking timeout, the  $\overline{\text{FAULT}}$  output asserts low. Ensure that the MAX1931's input is adequately bypassed to prevent input glitches from triggering spurious  $\overline{\text{FAULT}}$  outputs. Input voltage glitches less than 150mV do not cause a

# Current-Limited Switch for Single USB Port

spurious  $\overline{\text{FAULT}}$  output. Load-transient faults less than 10ms (typ) do not cause a  $\overline{\text{FAULT}}$  output assertion.

Only current-limit faults are blanked. Die overtemperature faults and input voltage droops below the UVLO threshold cause an immediate fault output.

## Applications Information

### Input Capacitor

To limit the input voltage drop during momentary output short-circuit conditions, connect a capacitor from IN to GND. A 1 $\mu\text{F}$  ceramic capacitor is adequate for most applications; however, higher capacitor values further reduce the voltage drop at the input (see Figure 2).

### Output Capacitor

Connect a 0.1 $\mu\text{F}$  capacitor from OUT to GND. This capacitor helps prevent inductive parasitics from pulling OUT negative during turn-off.

### Layout and Thermal Dissipation

To optimize the switch-response time to output short-circuit conditions, it is very important to keep all traces as short as possible to reduce the effect of undesirable parasitic inductance. Place input and output capacitors as close to the device as possible (no more than 5mm).

All IN and all OUT pins must be connected with short traces to the power bus. Wide power bus planes provide superior heat dissipation through the switch IN and OUT pins. Figure 3 shows suggested pin connections for a single-layer board.

Under normal operating conditions, the package can dissipate and channel heat away. Calculate the maximum power dissipation as follows:

$$P = (I_{\text{LIMIT}})^2 \times R_{\text{ON}}$$

where  $I_{\text{LIMIT}}$  is the preset current limit (1.1A max) and  $R_{\text{ON}}$  is the on-resistance of the switch (150m $\Omega$  max).

When the output is short-circuited, foldback-current-limiting activates and the voltage drop across the switch equals the input supply. The power dissipated across the switch increases, as does the die temperature. If the fault condition is not removed, the thermal-overload protection circuitry activates (see the *Thermal Shutdown* section). Wide power-bus planes connected to IN and OUT and a ground plane in contact with the device help dissipate additional heat.

## Chip Information

TRANSISTOR COUNT: 715

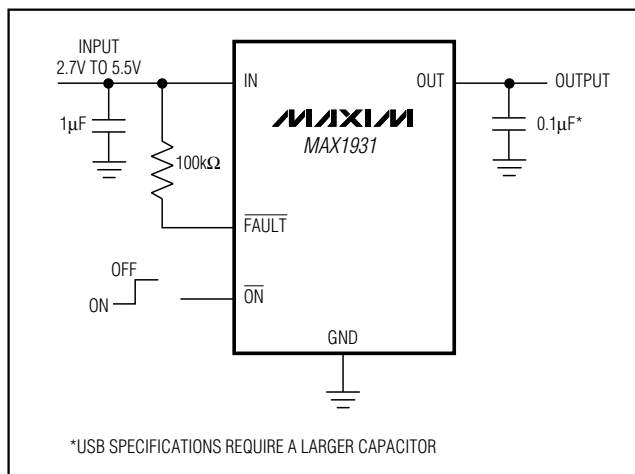

Figure 2. Typical Application Circuit

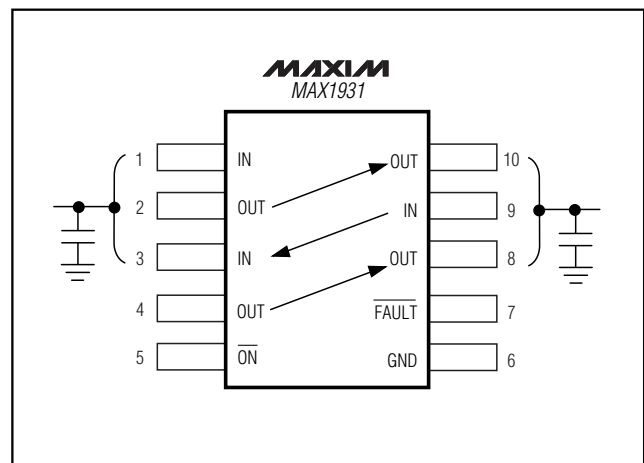

Figure 3. IN and OUT Cross Connections for a Single-Layer Board

# Current-Limited Switch for Single USB Port

## Package Information

(The package drawing(s) in this data sheet may not reflect the most current specifications. For the latest package outline information, go to [www.maxim-ic.com/packages](http://www.maxim-ic.com/packages).)

10LUMAX.EPS

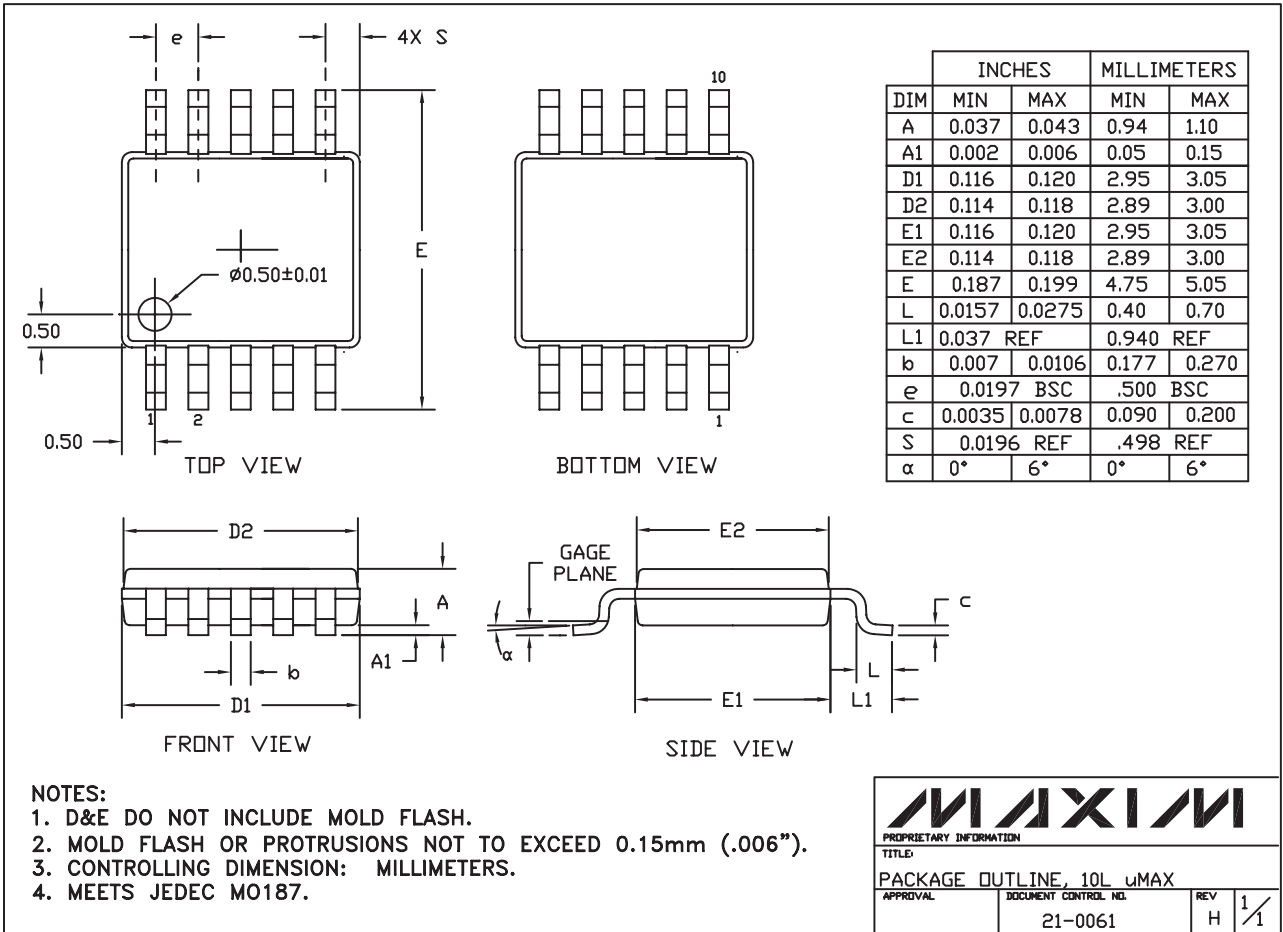

Note: MAX1931 does not have an exposed pad.

Maxim cannot assume responsibility for use of any circuitry other than circuitry entirely embodied in a Maxim product. No circuit patent licenses are implied. Maxim reserves the right to change the circuitry and specifications without notice at any time.

Maxim Integrated Products, 120 San Gabriel Drive, Sunnyvale, CA 94086 408-737-7600



## X-ON Electronics

Largest Supplier of Electrical and Electronic Components

*Click to view similar products for [Power Switch ICs - Power Distribution](#) category:*

*Click to view products by [Maxim](#) manufacturer:*

Other Similar products are found below :

[TCK111G,LF\(S\)](#) [FPF1018](#) [DS1222](#) [TCK2065G,LF](#) [SZNCP3712ASNT3G](#) [MIC2033-05BYMT-T5](#) [MIC2033-12AYMT-T5](#) [MIC2033-05BYM6-T5](#) [SLG5NT1437VTR](#) [SZNCP3712ASNT1G](#) [DML1008LDS-7](#) [KTS1670EDA-TR](#) [KTS1640QGDV-TR](#) [KTS1641QGDV-TR](#) [U6513A](#) [MIC2012YM-TR](#) [MP5095GJ-P](#) [TPS2021IDRQ1](#) [TPS2104DBVR](#) [TPS22958NDGKR](#) [MIC2098-1YMT-TR](#) [MIC94062YMT TR](#) [MP6231DN-LF](#) [MIC2015-1.2YM6 TR](#) [MIC2075-2YM](#) [MIC94068YML-TR](#) [SIP32461DB-T2-GE1](#) [NCP335FCT2G](#) [TCK105G,LF\(S\)](#) [AP2411S-13](#) [AP2151DSG-13](#) [AP2172MPG-13](#) [MIC94094YC6-TR](#) [MIC94093YC6-TR](#) [MIC94064YC6-TR](#) [MIC94061YMT-TR](#) [MIC2505-1YM](#) [MIC94085YFT-TR](#) [MIC94042YFL-TR](#) [MIC2005-1.2YM6-TR](#) [NCP333FCT2G](#) [NCP331SNT1G](#) [TPS2092DR](#) [TPS2063DR](#) [MIC2008YML-TR](#) [MIC94084YFT-TR](#) [MIC2040-1YMM](#) [DIO1280WL12](#) [AP22814ASN-7](#) [MIC2043-2YTS](#)