

General Description

The MAX20074 evaluation kit demonstrates the performance and behavior of the MAX20074, a part in the MAX20015–MAX20018/MAX20073/MAX20074 family of pin-compatible, low-voltage, step-down switching regulator ICs.

The regulator delivers current up to 3A at an output voltage between 0.5V and 3.8V. The device operates from a 2.7V to 5.5V input supply voltage, making it ideal for post-regulation and point-of-load applications. The total error over load, line, and temperature ranges is 1.5%. The base switching frequency is 2.2MHz, which allows for all-ceramic capacitor application designs. The regulator can either be synchronized to an external clock or placed in a power-saving skip mode for increased efficiency at light loads.

The regulator provides an enable input and fault flag output. The output voltage can be set using an external resistor-divider and an internal 0.5V reference. Alternatively, it can be programmed at the factory for a specific output voltage, achieving 1.5% output accuracy without resorting to expensive 0.1% resistors. The soft-start time and fault hold time can also be factory programmed.

The regulators include overtemperature shutdown and overcurrent limiting. They are designed to continuously operate over the -40°C to 125°C ambient temperature range.

Ordering Information appears at end of data sheet.

Benefits and Features

- 2.7V to 5.5V Input Voltage Range
- 0.5V to 3.8V Output Voltage Range
 - Set by External Resistive Divider or Preprogrammed at Factory
 - Base EV Kit Configuration Set to 1.8V/3A Output
- High-Frequency Switching (2.2MHz) Allows for an All-Ceramic Capacitor Design
- Continuously Produces Output Current Up to 3A
- Compact Solution Size
 - Externally Adjustable Output Implementation Fits Inside 65mm² Area
 - Preprogrammed Output Implementation Fits Inside 55mm² Area

Quick Start

Required Equipment

- MAX20074 EV kit
- 5V, 2A power supply
- Digital multimeter
- 0.6Ω, 20W power resistor or 3A electronic load

Procedure

The EV kit is fully assembled and tested. Follow the steps below to verify board operation:

- 1) Remove the jumper from JU1 (EN). Jumpers JU2 and JU3 can either be removed or populated.
- 2) Connect the power supply to VSUP and GND and activate the supply.
- 3) Use the multimeter to verify 5V input voltage and 0V output voltage.
- 4) Replace the jumper on JU1 (EN).
- 5) Use the multimeter to verify output voltage is 1.8V.
- 6) Connect load (either resistive or electronic) to VOUT and GND.
- 7) Use the multimeter to verify output voltage is still 1.8V.

Detailed Description of Hardware

The MAX20074 EV kit is fully assembled and tested. The EV kit comes with the MAX20074ATBA/V+ installed. Other regulators in the family can be tested on the same EV kit with IC replacement of U1. Changing either the IC or the output configuration may also require changing the external components. Consult the MAX20074 IC data sheet for guidance on selecting the proper components.

EV Kit Interface

The VSUP and GND test points provide power to the EV kit. Capacitor C7 emulates the output capacitance of a primary regulator feeding the EV kit. Additional capacitance can be connected across VSUP and GND, if desired. The regulator provides output power at the OUT and GND pins. The standard 1.8V configuration requires only one output capacitor, but additional capacitor lands are provided in case lower output voltages are tested.

The IC is enabled by populating a shunt across JU1 or applying a logic-high voltage at the EN test loop. The EN pin has a weak internal pulldown, so leaving the line disconnected causes the regulator to shut off. Upon enabling, the output voltage ramps upwards from zero to the target output over the soft-start time.

Synchronization and Switching

The IC has the ability to operate in either forced-PWM (FPWM) mode or skip mode. Removing the jumper from JU2 causes the device to enter skip mode at low output currents to boost efficiency (a weak internal pull-down on the SYNC pin causes the device to default to this mode when the SYNC pin is otherwise left open). Populating a jumper on JU2 or applying a logic-high signal to the SYNC pin causes the device to enter FPWM mode. Also, a square wave can be applied to the SYNC pin to cause the device to switch at that frequency.

The MAX20074 can be programmed at the factory to output its switching frequency on the SYNC pin (the default device populated on the EV kit does not behave in this manner). ICs configured this way always operate in FPWM mode. The square-wave output is offset 180° from the device's switching behavior.

A spread-spectrum feature is available to reduce peak EMI emissions. Placing a jumper on JU3 activates spread spectrum on the power MOSFET switching frequency. Removing the jumper from JU3 changes back to fixed-frequency switching (the SSEN pin on the device has a weak internal pulldown for a default state of spread spectrum or deactivated if the pin is left open). Applying a square wave to the SYNC pin for synchronization overrides the spread-spectrum behavior.

Fault Flag Signal (RESET)

The device signals the presence/absence of fault conditions through the RESET pin. An external pullup resistor on the EV kit pulls the pin up to the supply voltage. The pin has an open-drain configuration for the signal to interface with other logic voltage levels. Under fault conditions, the open-drain FET closes and pulls the line down to ground. Under normal conditions, the FET opens and the line is pulled up.

PCB Layout Guidelines

Proper PCB layout of the system is crucial for good performance. The loop area created by the DC-DC components must be minimized as much as possible. Place the PV (input) capacitor, power inductor, and output capacitor very close to the device. Increasing the loop area increases EMI and switching jitter, and can also degrade regulation and transient response. The optimal positioning and routing for the three components is implemented on the EV kit and described below.

Place several vias in the exposed pad (EP) of the device. Connect EP to ground, both on the outer layer and to all inner ground layers (using said vias). A grid of small vias (2x3 grid of 0.010in diameter) is recommended. Connecting EP to multiple ground layers provides sufficient thermal sinking.

A low-impedance ground connection to the device and its associated components is critical. Use a size 1206 PV capacitor next to the device, directly adjacent to the PV and GND pins. Route the LX trace out from the device, going underneath the PV capacitor, to the inductor. Place the output capacitor(s) GND pins next to the PV capacitor GND pin. The layer directly below the device and its circuitry needs to be a large ground plane. Do not use separate analog and power grounds; use a single common ground, as the high-frequency return current flows on the ground plane directly below the associated components and traces and away from other circuitry. Use several vias next to the capacitor and device GND pins for low-impedance connections to the ground plane (these are in addition to the vias in the device EP mentioned previously).

Ordering Information

PART	TYPE
MAX20074EVKIT#	EV Kit

#Denotes RoHS compliant.

MAX20074 EV Bill of Materials

ITEM	QTY	REFERENCE	VALUE	DESCRIPTION	MANUFACTURER PART NUMBER
1	1	C1	4.7u	Capacitor, ceramic, 4.7µF, 10V, X7R, 1206 size	Murata GCM31CR71C475KA37L
2	1	C2	1.0u	Capacitor, ceramic, 1.0µF, 10V, X7S, 0402 size	Murata GCM155C71A105KE38D
3	1	C3	22p	Capacitor, ceramic, 22pF, 50V, C0G/NP0, 0402 size	TDK CGA2B2C0G1H220J050BA
4	1	C4	47u	Capacitor, ceramic, 47µF, 6.3V, X6S, 1206, size	Murata GRT31CC80J476KE13L
5	2	C5, C6	N.C.		
6	1	C7	47u	Capacitor, ceramic, 47µF, 10V, X6S, 1210, size	Murata GRT32EC81A476KE13L
7	1	L1	0.68u	Inductor, thin-film, 0.68µH, 2.5mm x 2.0mm	TDK TFM252010ALMAR68M
8	2	R1, R3	10	Resistor, 10Ω, 1%, 0402 size	any
9	1	R2	10k	Resistor, 20kΩ, 1%, 0402 size	any
10	1	R4	39.2k	Resistor, 39.2kΩ, 1%, 0402 size	any
11	1	R5	15k	Resistor, 15kΩ, 1%, 0402 size	any
12	1	U1	MAX20074	Step-down regulator, low-voltage, 3A	MAX20074ATBA/V+

MAX20074 EV Schematics

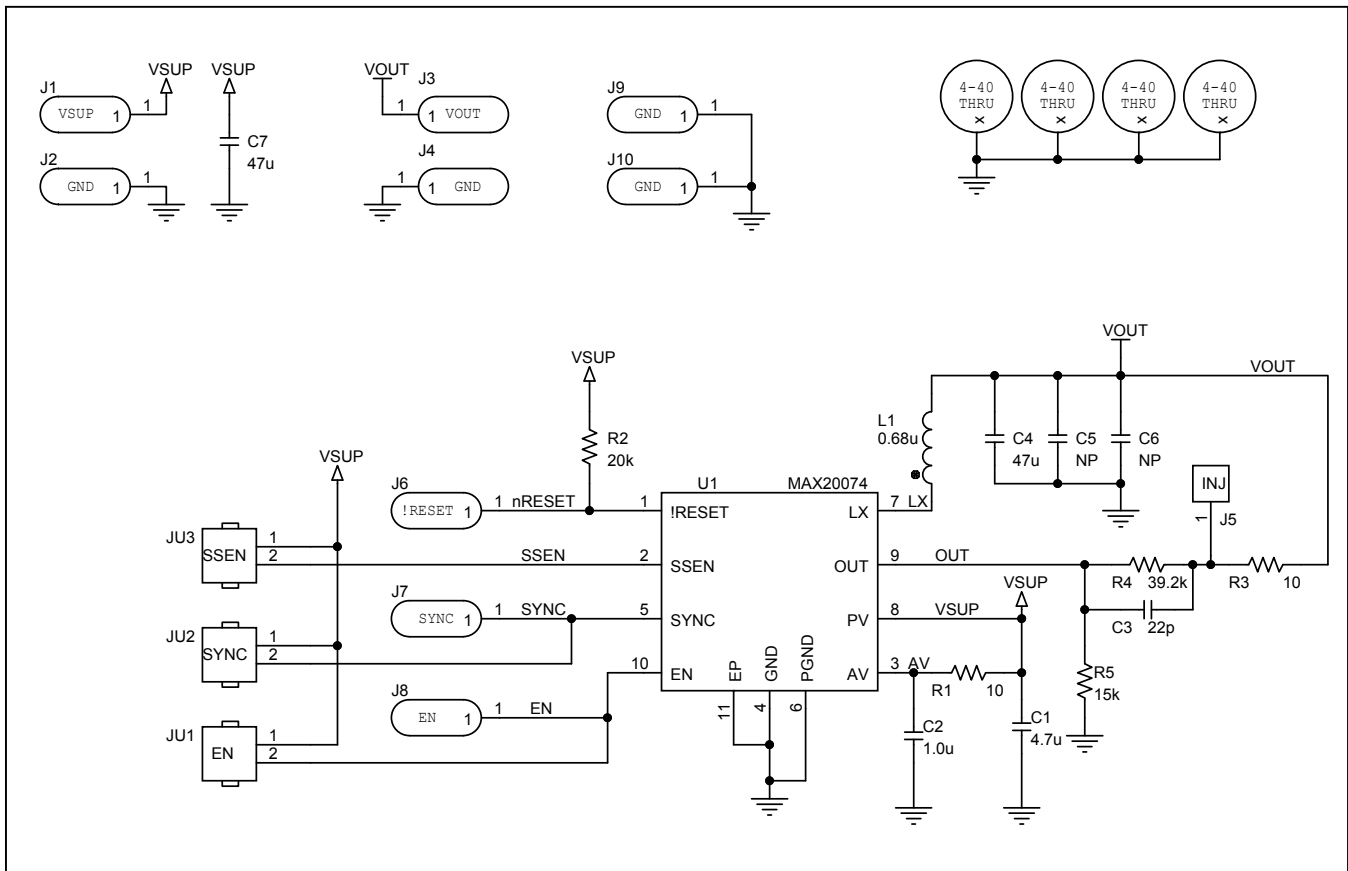

MAX20074 EV PCB Layout

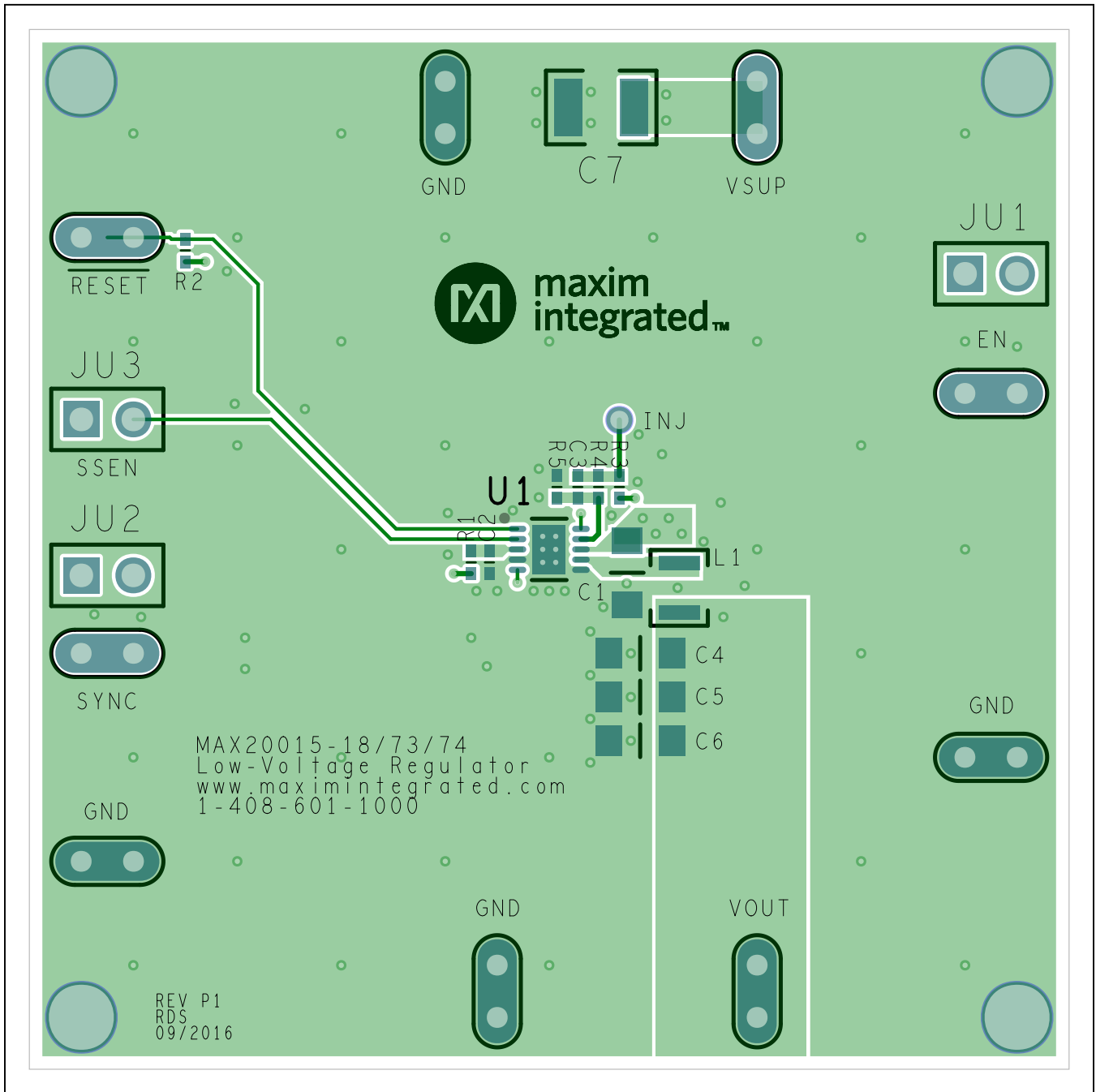

Top Layout

MAX20074 EV PCB Layout (continued)

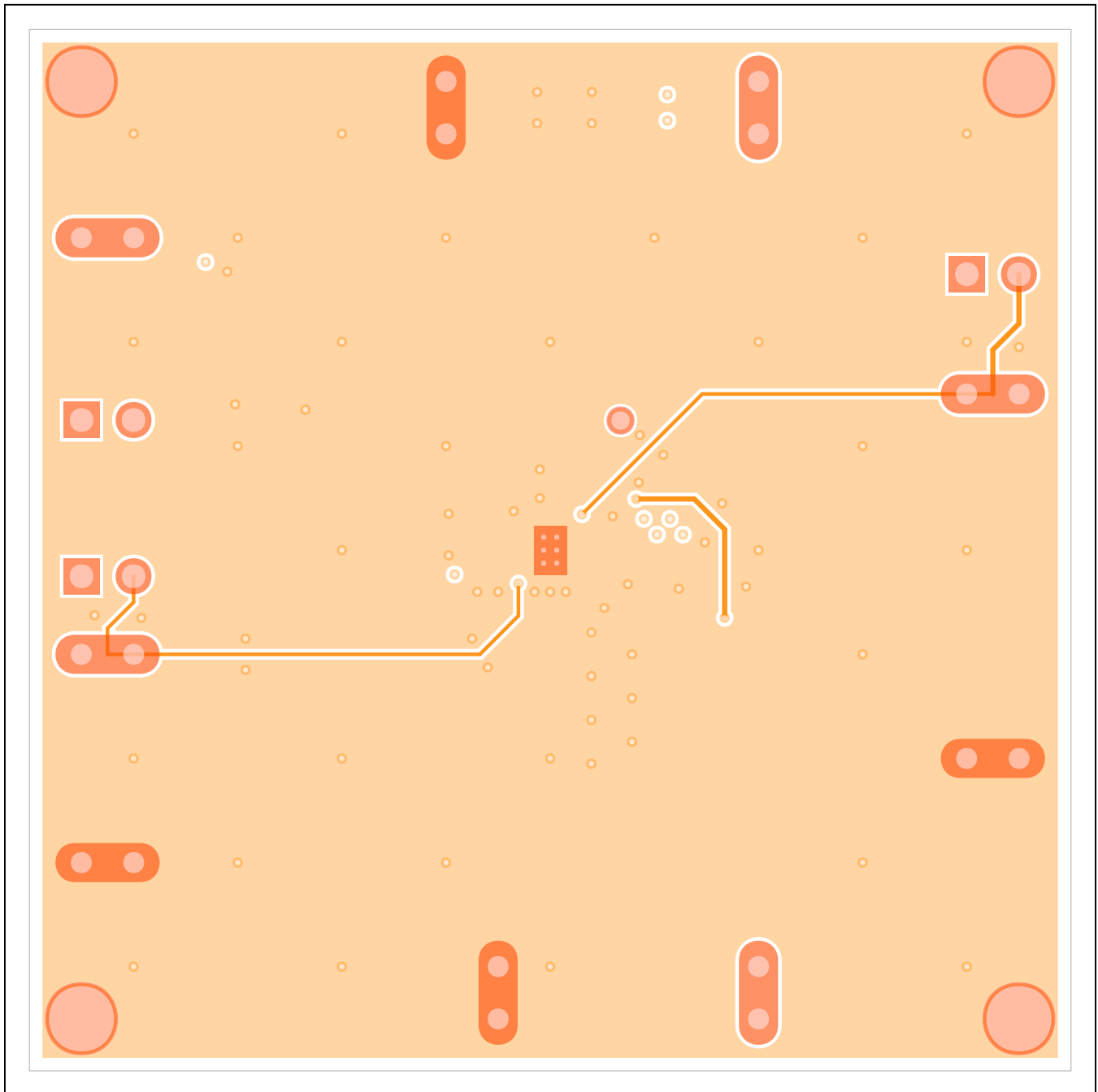

Bottom Layout (Inner Ground and Power Layers Not Shown.)

Revision History

REVISION NUMBER	REVISION DATE	DESCRIPTION	PAGES CHANGED
0	10/16	Initial release	—

For pricing, delivery, and ordering information, please contact Maxim Direct at 1-888-629-4642, or visit Maxim Integrated's website at www.maximintegrated.com.

Maxim Integrated cannot assume responsibility for use of any circuitry other than circuitry entirely embodied in a Maxim Integrated product. No circuit patent licenses are implied. Maxim Integrated reserves the right to change the circuitry and specifications without notice at any time.

X-ON Electronics

Largest Supplier of Electrical and Electronic Components

Click to view similar products for [Power Management IC Development Tools](#) category:

Click to view products by [Maxim](#) manufacturer:

Other Similar products are found below :

[EVB-EP5348UI](#) [MIC23451-AAAYFL EV](#) [MIC5281YMME EV](#) [124352-HMC860LP3E](#) [DA9063-EVAL](#) [ADP122-3.3-EVALZ](#) [ADP130-0.8-EVALZ](#) [ADP130-1.8-EVALZ](#) [ADP1740-1.5-EVALZ](#) [ADP1870-0.3-EVALZ](#) [ADP1874-0.3-EVALZ](#) [ADP199CB-EVALZ](#) [ADP2102-1.25-EVALZ](#) [ADP2102-1.875EVALZ](#) [ADP2102-1.8-EVALZ](#) [ADP2102-2-EVALZ](#) [ADP2102-3-EVALZ](#) [ADP2102-4-EVALZ](#) [AS3606-DB](#) [BQ25010EVM](#) [BQ3055EVM](#) [ISLUSBI2CKIT1Z](#) [LP38512TS-1.8EV](#) [EVAL-ADM1186-1MBZ](#) [EVAL-ADM1186-2MBZ](#) [ADP122UJZ-REDYKIT](#) [ADP166Z-REDYKIT](#) [ADP170-1.8-EVALZ](#) [ADP171-EVALZ](#) [ADP1853-EVALZ](#) [ADP1873-0.3-EVALZ](#) [ADP198CP-EVALZ](#) [ADP2102-1.0-EVALZ](#) [ADP2102-1-EVALZ](#) [ADP2107-1.8-EVALZ](#) [ADP5020CP-EVALZ](#) [CC-ACC-DBMX-51](#) [ATPL230A-EK](#) [MIC23250-S4YMT EV](#) [MIC26603YJL EV](#) [MIC33050-SYHL EV](#) [TPS60100EVM-131](#) [TPS65010EVM-230](#) [TPS71933-28EVM-213](#) [TPS72728YFFEVM-407](#) [TPS79318YEQEVM](#) [UCC28810EVM-002](#) [XILINXPWR-083](#) [LMR22007YMINI-EVM](#) [LP38501ATJ-EV](#)