

MAX20077 Evaluation Kit

Evaluates: MAX20077/MAX25277

General Description

The MAX20077 evaluation kit (EV kit) provides a proven design to evaluate the MAX20077/MAX25277 2.1MHz/400kHz high-voltage mini-buck converter in a 12-pin side-wettable TDFN package. All components are rated for the automotive temperature range. Various test points and jumpers are included for evaluation.

The standard EV kit comes with the MAX20077ATCA/VY+ installed (5V, 2.1MHz), but it can also be used to evaluate other MAX20077/MAX25277 variants with minimal component changes (e.g., IC replacement of U1).

Benefits and Features

- 3.5V to 36V Input Supply Range
- 5V or 3.3V Fixed Output Voltage, or Adjustable Between 1V and 10V
- Delivers Up to 2.5A Output Current
- Frequency-Synchronization Input
- Enable Input
- Voltage-Monitoring PGOOD Output
- Proven PCB Layout
- Fully Assembled and Tested

Quick Start

Required Equipment

- MAX20077 EV kit
- Power supply
- Voltmeter
- Electronic load

Procedure

The EV kit is fully assembled and tested. Follow the steps below to verify board operation:

- 1) Verify that all jumpers are in their default positions, as shown in [Table 1](#).
- 2) Connect the positive and negative terminals of the power supply to the SUP and GND test pads, respectively.
- 3) Connect the positive terminal of the voltmeter to OUT and the negative terminal to GND2.
- 4) Set the power supply to 14V and 2A current limit. Turn on the power supply.
- 5) With the PU and LED headers shorted, the green LED lights up. The voltmeter should display an output voltage of 5V.

[Ordering Information](#) appears at end of data sheet.

Table 1. Default Jumper Settings

JUMPER	SHUNT POSITION	FUNCTION
EN	ON-Middle	Buck controller enabled
SPS	Middle-OFF	Spread spectrum disabled
PU, LED	Installed	PGOOD is pulled up by V_{BIAS} when OUT is in regulation
SYNC	Middle-FPWM	Forced-PWM mode

Detailed Description

The MAX20077 EV kit provides a proven layout for evaluating all variants of the MAX20077/MAX25277 family of small, current-mode-controlled buck converter ICs. Each device accepts input voltages as high as 36V and delivers up to 2.5A. The EV kit can handle an input-supply transient up to 40V.

Switching Frequency and External Synchronization

The ICs can operate in two modes, forced-PWM or skip. Skip mode has better efficiency for light-load conditions. When SYNC is pulled low, the device operates in skip mode for light loads, and in PWM mode for larger loads. When SYNC is pulled high, the device is forced to operate in PWM across all load conditions.

SYNC can be used to synchronize with other supplies if a clock source is present. The device is forced to operate in PWM when SYNC is connected to a clock source.

Buck Output Monitoring (PGOOD)

The EV kit provides a power-good output test point (PGOOD) to monitor the status of the buck output (OUT). PGOOD is low impedance when the output voltage is in regulation. PGOOD is high impedance when the output voltage drops below 8% (typ) of its nominal regulated voltage.

To obtain a logic signal, pull up PGOOD to V_{BIAS} by installing shunts on jumpers PU and LED.

Evaluating Other Variants

The EV kit comes installed with the fixed-output, 5V/2.1MHz variant (MAX20077ATCA/VY+). The 2.1MHz and 400kHz

variants can be installed and tested with minimal component changes. For the 2.1MHz variants, install the appropriate IC on the EV kit (U1), while keeping all other components the same. For 400kHz parts, the inductor should be increased to 10 μ H, and the output capacitance must be a minimum 44 μ F after derating is accounted for. For MAX20077ATCE2 and MAX20077ATCD2 high-bandwidth parts, increase the output capacitance as per the guidelines in the IC datasheet.

The MAX20077ATCC/VY+ can be installed for output voltages between 1V and 3V (2.1MHz). The inductor should be set to 4.7 μ H, and the output capacitance must be a minimum 44 μ F after derating is accounted for. The output voltage must be externally adjusted.

Setting the Output Voltage in the Buck Converters

To externally adjust the output voltage, remove R1 and install a 0 Ω resistor on R4. Place appropriate resistors in positions R5 and R6 according to the following equation:

$$R5 = R6 \left[\left(\frac{V_{OUT}}{V_{FB}} \right) - 1 \right]$$

where $V_{FB} = 1V$ (typ) and $R6 = 50k\Omega$.

Ordering Information

PART	TYPE
MAX20077EVKIT#	5V output, 2.1MHz EV kit

#Denotes RoHS compliant.

MAX20077 EV Kit Bill of Materials

DESIGNATION	QTY	DESCRIPTION
C1	1	4.7uF ±10%, 50V X7R ceramic capacitors (1210) TDK CGA6P3X7R1H475K250AB
C2	1	47uF, 50V aluminum electrolytic capacitor (8.3mm x 8.3mm) Panasonic EEE-FK1H470P
C3, C4, C5	3	10uF ±10%, 25V X7R ceramic capacitor (1206) Taiyo Yuden TMJ316BB7106KLHT
C7	1	1uF ±10%, 35V X7R ceramic capacitor (0603) TDK CGA3E1X7R1V105K080AC
C8	1	0.1uF ±10% 50V X7R ceramic capacitor (0402) TDK CGA2B3X7R1H104K
C10, C11	2	2.2uF ±10% 50V X7R ceramic capacitor (1210) TDK CGA6M3X7R1H225K200AB
DS1	1	Green LED (0603) Lite-On Electronics LTST-C191KGKT
EN, SPS, SYNC	3	3-pin headers (0.1" spacing)
L1	1	2.2µH Power Inductor Coilcraft XFL5030-222
L2	1	2A Ferrite Bead (1210) Taiyo Yuden FBMH3225HM102NT
PU, LED	2	2-pin headers (0.1" spacing)
R1, R2	2	0Ω resistor (0603)
R3	1	3kΩ ±5% resistor (0603)
U1	1	Automotive Mini-Buck (12-pin SWTDFN) Maxim MAX20077ATCA/VY+
—	5	Shunt Jumper (0.1" spacing, Black)
—	1	PCB: MAX20077 Evaluation Kit

MAX20077 EV Kit Schematic

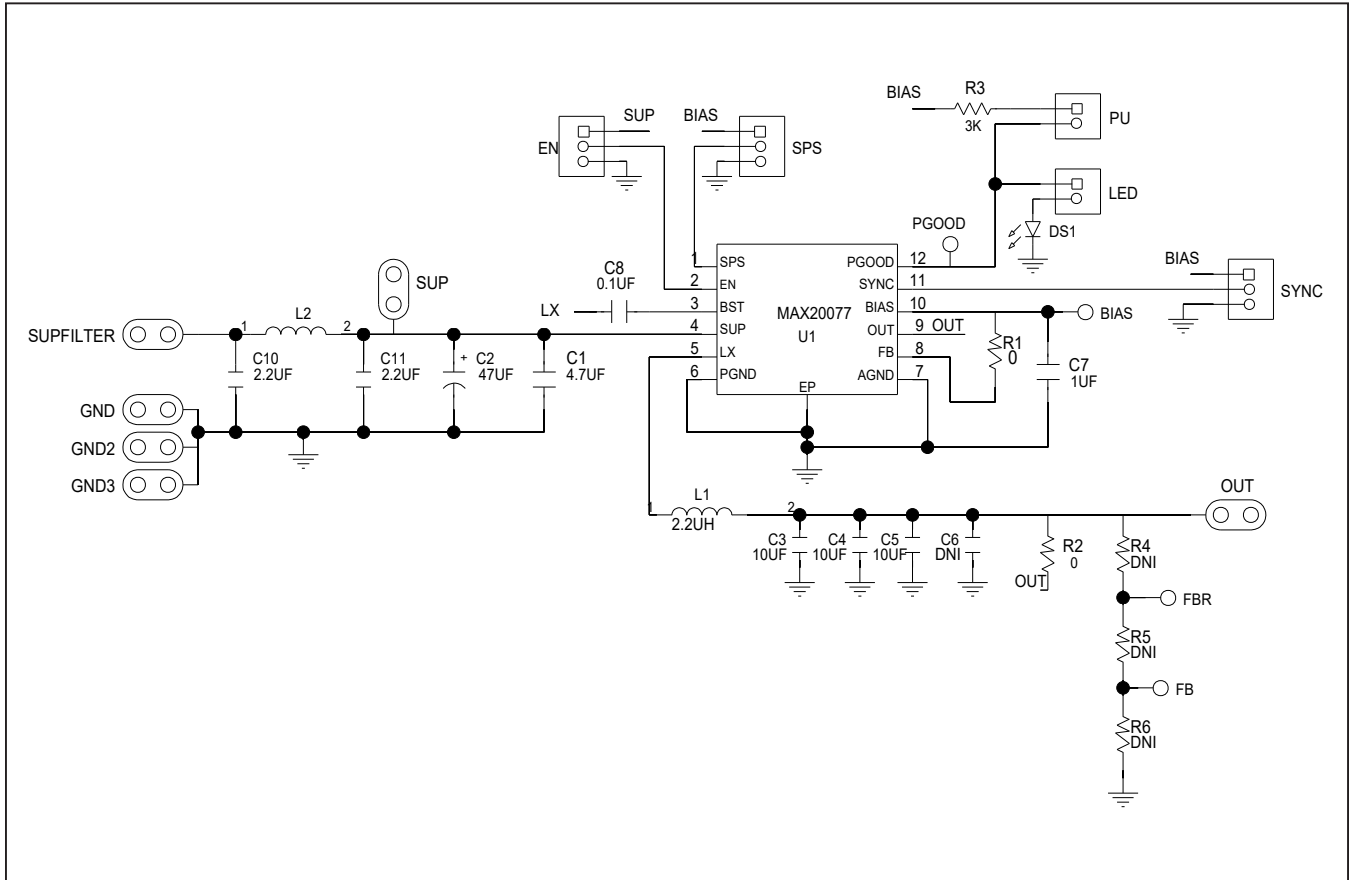

MAX20077 EV PCB Layouts

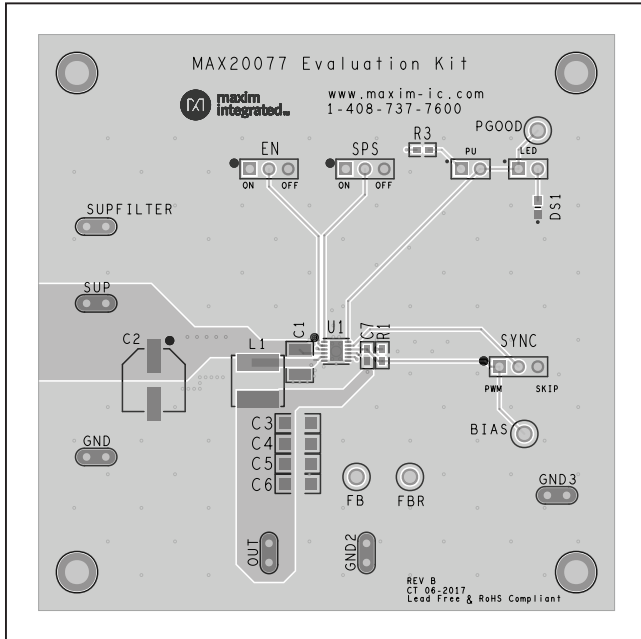

MAX20077 EV Kit Component Placement Guide—Top

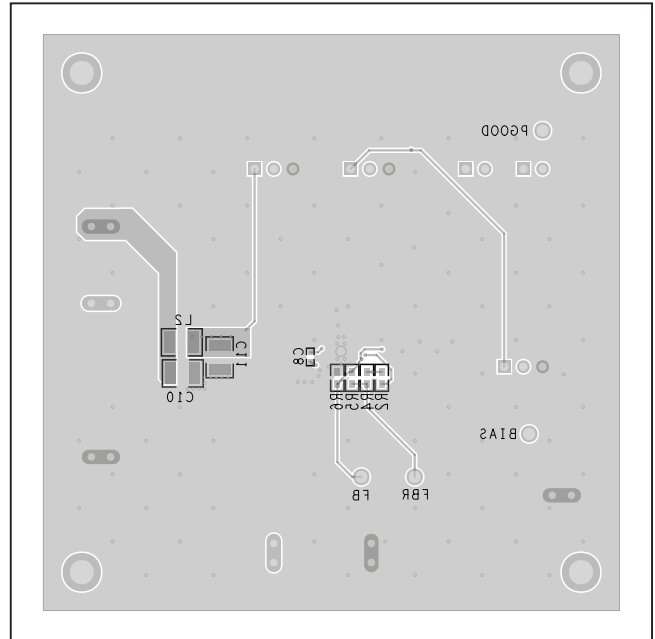

MAX20077 EV Kit Component Placement Guide—Bottom

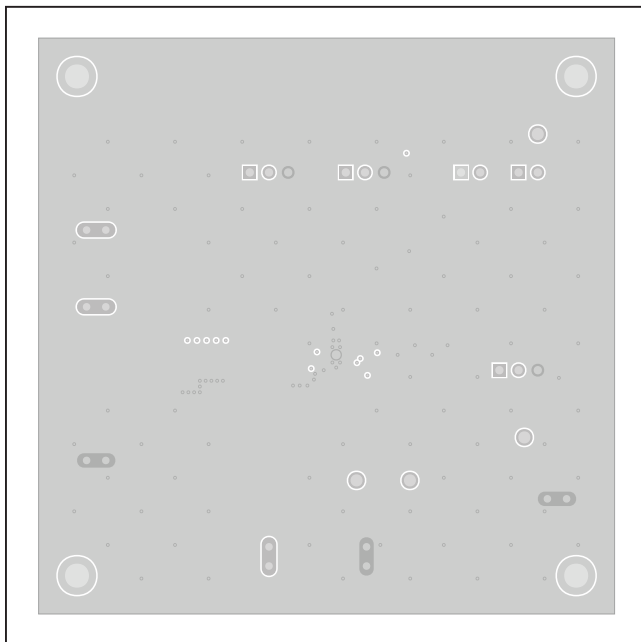

MAX20077 EV Kit PCB Layout—Internal Layer 2

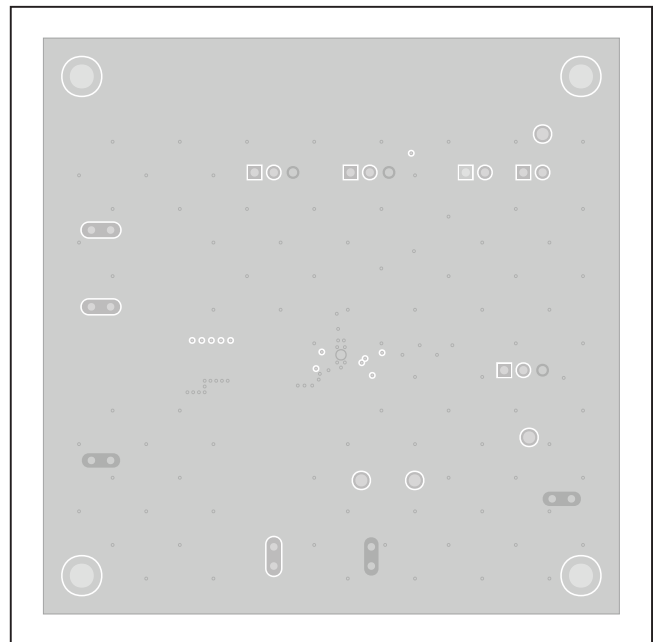

MAX20077 EV Kit PCB Layout—Internal Layer 3

Revision History

REVISION NUMBER	REVISION DATE	DESCRIPTION	PAGES CHANGED
0	3/18	Initial release	—
1	12/18	Added MAX25277	1–5
2	2/19	Removed MAX25277 from references to EV kit title	1–5

For pricing, delivery, and ordering information, please visit Maxim Integrated's online storefront at <https://www.maximintegrated.com/en/storefront/storefront.html>.

Maxim Integrated cannot assume responsibility for use of any circuitry other than circuitry entirely embodied in a Maxim Integrated product. No circuit patent licenses are implied. Maxim Integrated reserves the right to change the circuitry and specifications without notice at any time.

X-ON Electronics

Largest Supplier of Electrical and Electronic Components

Click to view similar products for [Power Management IC Development Tools](#) category:

Click to view products by [Maxim](#) manufacturer:

Other Similar products are found below :

[EVB-EP5348UI](#) [MIC23451-AAAYFL EV](#) [MIC5281YMME EV](#) [124352-HMC860LP3E](#) [DA9063-EVAL](#) [ADP122-3.3-EVALZ](#) [ADP130-0.8-EVALZ](#) [ADP130-1.8-EVALZ](#) [ADP1740-1.5-EVALZ](#) [ADP1870-0.3-EVALZ](#) [ADP1874-0.3-EVALZ](#) [ADP199CB-EVALZ](#) [ADP2102-1.25-EVALZ](#) [ADP2102-1.875EVALZ](#) [ADP2102-1.8-EVALZ](#) [ADP2102-2-EVALZ](#) [ADP2102-3-EVALZ](#) [ADP2102-4-EVALZ](#) [AS3606-DB](#) [BQ25010EVM](#) [BQ3055EVM](#) [ISLUSBI2CKIT1Z](#) [LP38512TS-1.8EV](#) [EVAL-ADM1186-1MBZ](#) [EVAL-ADM1186-2MBZ](#) [ADP122UJZ-REDYKIT](#) [ADP166Z-REDYKIT](#) [ADP170-1.8-EVALZ](#) [ADP171-EVALZ](#) [ADP1853-EVALZ](#) [ADP1873-0.3-EVALZ](#) [ADP198CP-EVALZ](#) [ADP2102-1.0-EVALZ](#) [ADP2102-1-EVALZ](#) [ADP2107-1.8-EVALZ](#) [ADP5020CP-EVALZ](#) [CC-ACC-DBMX-51](#) [ATPL230A-EK](#) [MIC23250-S4YMT EV](#) [MIC26603YJL EV](#) [MIC33050-SYHL EV](#) [TPS60100EVM-131](#) [TPS65010EVM-230](#) [TPS71933-28EVM-213](#) [TPS72728YFFEVM-407](#) [TPS79318YEQEVM](#) [UCC28810EVM-002](#) [XILINXPWR-083](#) [LMR22007YMINI-EVM](#) [LP38501ATJ-EV](#)